



**KTI Hydraulics Inc.**  
**Santa Ana, California**  
**ISO 9001:2015 Certified**



2621 S. Daimler St.  
 Santa Ana, CA 92705  
 Tel. (949) 752-8818  
 Fax (949) 756-1520  
[www.ktihydraulicsinc.com](http://www.ktihydraulicsinc.com)

## Table of Contents

Introduction to KTI.....	03
How to Order Modular Power Unit.....	04
Universal Manifolds.....	06
Power Unit Models – Example Configurations .....	19
Submerged Hydraulic Power Unit .....	42
Components .....	
Motors – DC .....	45
Motors – AC .....	50
Pressure Loaded Gear Pumps .....	52
Valve Pack .....	55
Flow Dividers.....	57
Reservoirs .....	58
Controllers.....	
KWR-004 .....	61
KWR-005, KWR-006 .....	62
Support .....	
Installation / Service.....	63
Fluid Recommendations .....	64
Limited Warranty / RGA .....	65
Bleed Cycle Steps.....	67



2621 S. Daimler St.  
Santa Ana, CA 92705  
Tel. (949) 752-8818  
Fax (949) 756-1520  
[www.ktihydraulicsinc.com](http://www.ktihydraulicsinc.com)

KTI Hydraulics Inc., was established in 1997. The vision of our two founders, George King and Robert W. Habermann, was the KTI design philosophy for the original *Universal Manifold*<sup>®</sup> concept.

The concept has inherent integral features that are incorporated in the machined *Universal Manifold*<sup>®</sup>. It weighs less than 2 pounds, has eighteen basic hydraulic circuits, allows the use of an assortment of optional pumps with different displacements, a selection of reservoirs with different capacities and will mount to both AC and DC motors.

The basic four cavities (“H” concept) uses SAE O-ring cap plugs, cavity plugs or self-contained functional cartridge valves. This hardware assortment allows the design to achieve any one of the six basic single acting hydraulic circuits.

An external mounting surface is also incorporated in machined *Universal Manifold*<sup>®</sup> design. It allows for custom multiple valve circuits to be mounted on the basic power unit. Preformed cavities allow the use of hexagon or square steel nuts to lock the body in place for aluminum to aluminum retention.

In 2002, the *Universal Manifold*<sup>®</sup> was conceived and developed for double acting applications. This design complemented the *Universal Manifold*<sup>®</sup> I design. The two designs greatly expanded our circuit selection. In 2004, the *Universal Manifold*<sup>®</sup> III was developed for dual double acting applications. Then it was adopted for standard snow plow circuit with power angling, crossover relief & lift check, lower with float function. From the snow plow circuit, we were able to design a Double Acting & Single Acting function in one manifold without requiring an additional hydraulic manifold.

All KTI Hydraulics power units are 100% fully inspected to stringent test specifications. The tests ensure to our customers that they will receive reliable, high quality hydraulic power systems that will perform to our design specifications.



## HOW TO ORDER AC/DC POWER UNITS

### CIRCUIT

1	
---	--



A	101
B	102
G	102A RV Only
H	102B CV Only
C	103
R	103A
D	104A
E	104B
F	105
I	106
K	108
M	110
N	111
Q	114
S	114A
Y	114B
Z	114C
AA	114D
AB	115
T	208
U	211
V	215
X	216
AC	217

### PUMP

2	
---	--



PL  $\text{in}^3/\text{r}$

M	PL-0.63-11T (0.0383)
L	PL-0.80-11T (0.0543)
B	PL-1.20-11T (0.0775)
O	PL-1.50-11T (0.0915)
C	PL-1.60-11T (0.1013)
D	PL-2.10-11T (0.1324)
N	PL-2.50-11T (0.1525)
E	PL-2.70-11T (0.1709)
G	PL-3.20-11T (0.2026)
H	PL-4.20-11T-ES (0.2625)
I	PL-5.10-11T-ES (0.3113)
J	PL-6.00-11T-ES (0.3681)

\* All pump shafts are 11-tooth male spline

\* Tang shafts available upon request and result in longer lead times

\* Other displacements available upon request

### MOTOR

3	
---	--



#### DC MOTORS

A	12V DC, 4.5" OD 2 terminal 1.6 kW
B	12V DC, 3.0" OD 2 terminal
C	24V DC, 4.5" OD 2 terminal
R	12/24V DC, 5.0" OD 2 terminal, OEFC

\* 36/48 VDC MOTOR, IP-65, THERMAL PROTECTION AVAILABLE UPON REQUEST

\* THE FOLLOWING 12V DC, 4.5" MOTORS ARE AVAILABLE UPON REQUEST - 1.8 kW, 2.0 kW, 2.2 kW

\* OTHER MOTORS AVAILABLE. PLEASE CONTACT FACTORY FOR SPECIAL REQUESTS

#### AC MOTORS

	HP	PH	V	RPM	ENC
D	0.5	1	115-230	1750	TEFC
E	0.5	3	230-460	1750	TEFC
H	1.0	1	115-230	1750-3450	TEFC
I	1.0	3	230-460	1750-3450	TEFC
O	1.5	1	115-230	1750-3450	TEFC
T	1.5	3	230-460	1750	TEFC
L	2.0	1	230	1750-3450	TEFC
M	2.0	3	230-460	1750-3450	TEFC
J	3.0	1	230	3450	TEFC
K	3.0	3	230-460	3450	TEFC
S	5.0	1	230	3450	ODP
F	3/4	1	115-230	1725	ODP

## HOW TO ORDER AC/DC POWER UNITS

RESERVOIR		MOUNTING		MISC.		SPECIAL		RV SET (secondary)	
4		5		6		7		8 /	
K	1.5 qt	steel deep drawn	A	Horizontal	F	None		G	1000 PSI
A	2.0 qt		B	Vertical	A	Heavy Duty Start Solenoid		B	1500 PSI
B	3.0 qt		C	Pump Motor	B	Cont. Duty Start Solenoid		C	2000 PSI
C	4.0 qt				C	AC Start Switch		A	2500 PSI
D	4.0 qt	steel offset			D	DC Manual Start 106		D	3000 PSI
E	6.0 qt				E	Remote Pendant 12/24VDC		E	3500 PSI
F	8.0 qt				G	AC Remote 115V 1PH		F	Other
G	10 qt				H	AC Remote 220V 1PH			
H	12 qt			I	AC Remote 115V 1 PH, 4-BUTTON				
I	3.0 qt	plastic square			J	AC Remote 115V 1 PH, 3-BUTTON			
O	4.0 qt								
P	6.0 qt								
Q	8.0 qt								
R	10 qt								
J	14 qt								
T	16 qt								
U	2.0 gal	steel square						A	None
L	3.0 gal							B	Snow Plow - 12V
M	4.0 gal							C	4W2P.POC - 12V
N	5.0 gal							D	4W2P.POC - 24V
W	6.0 gal							E	4W2P.POC - 115V
V	7.0 gal							F	4W3P.POC - 12V
							G	4W3P.POC - 24V	
							H	4W3P.POC - 115V	
							I	DO3 Transition	
							II	Dual DO3 Transition	

\* Not to exceed 4000 PSI.

\* Reservoir volumes listed here are based on horizontal mount. We have many other sizes not listed so please inquire if you have a specific need



# UNIVERSAL MANIFOLD I

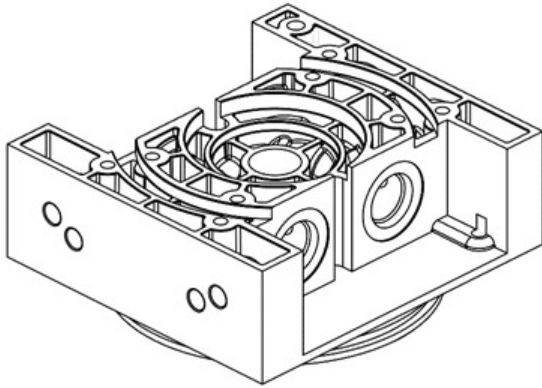

## OVERVIEW

Universal Manifold I (UM-I) is primarily used for single acting applications and has the ability to extend towards double acting applications and circuits. See page 51 regarding stackable manifolds for a description of this feature.

## HYDRAULIC CIRCUITS

101, 102, 102A, 102B, 103, 103A, 104A, 104B, 105, 106

## OUTLET

"P" & "T" Port SAE #6 ORB 9/16-18

### HYDRAULIC CIRCUIT 101

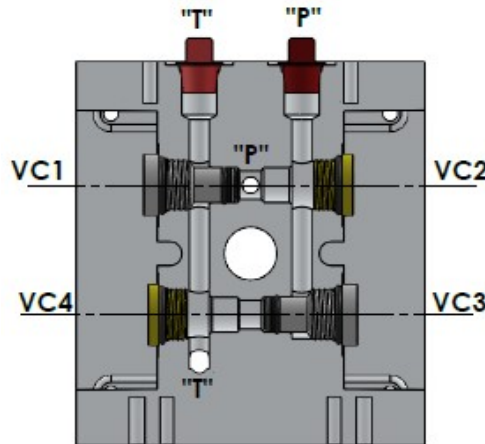
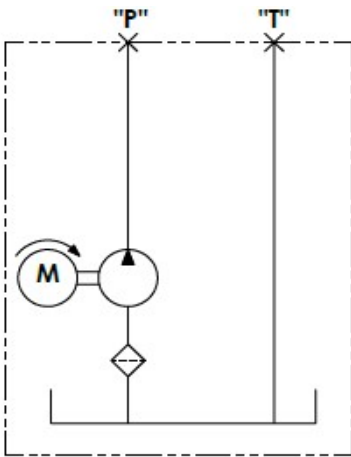

- VC1:** VALVE CAVITY PLUG
- VC2:** VALVE PLUG
- VC3:** VALVE CAVITY PLUG
- VC4:** VALVE PLUG

### HYDRAULIC CIRCUIT 102

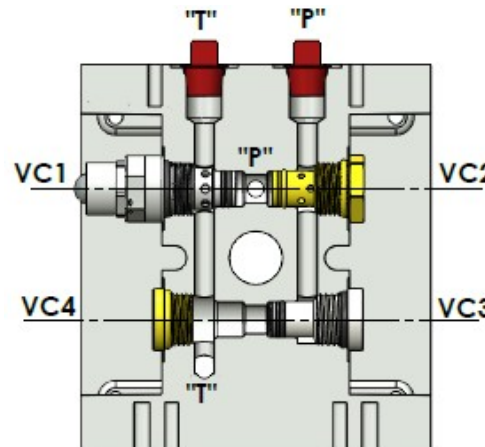
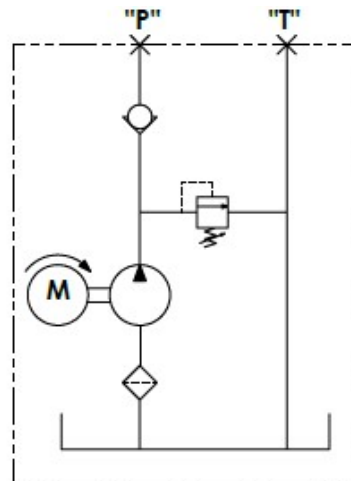

- VC1:** CARTRIDGE RELIEF VALVE
- VC2:** CARTRIDGE CHECK VALVE
- VC3:** VALVE CAVITY PLUG
- VC4:** VALVE PLUG

# UNIVERSAL MANIFOLD I

HYDRAULIC CIRCUIT 102A

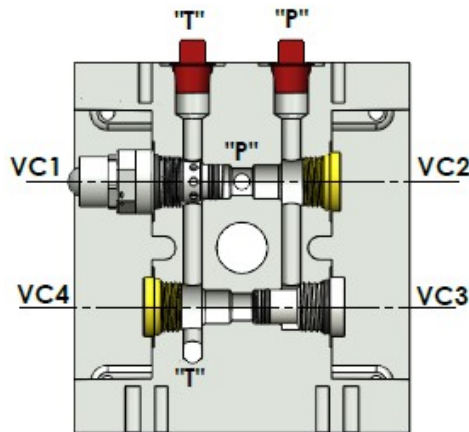
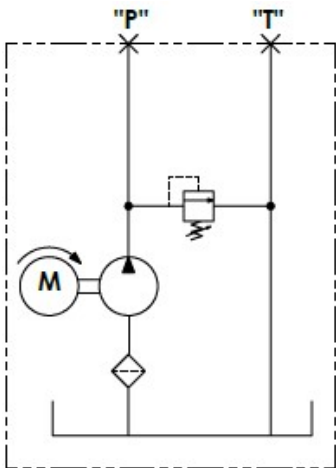

- VC1: CARTRIDGE RELIEF VALVE
- VC2: VALVE PLUG
- VC3: VALVE CAVITY PLUG
- VC4: VALVE PLUG

HYDRAULIC CIRCUIT 102B

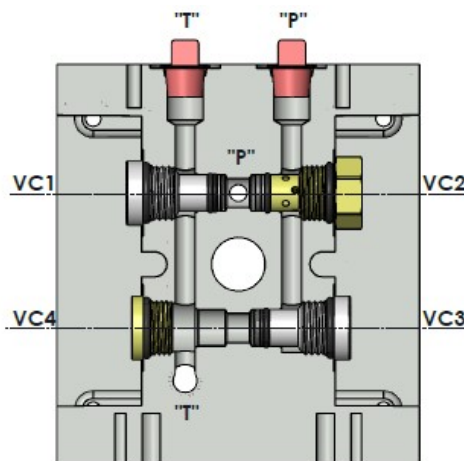
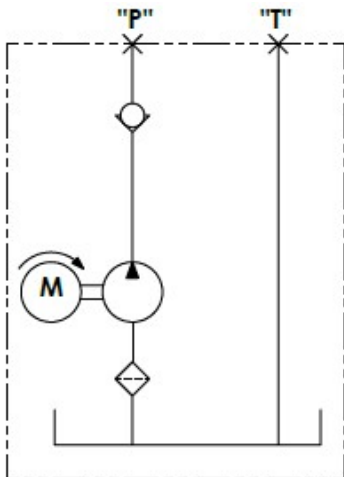

- VC1: VALVE CAVITY PLUG
- VC2: CARTRIDGE CHECK VALVE
- VC3: VALVE CAVITY PLUG
- VC4: VALVE PLUG

HYDRAULIC CIRCUIT 103

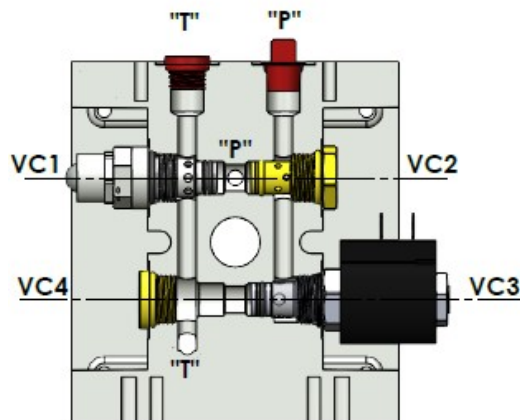
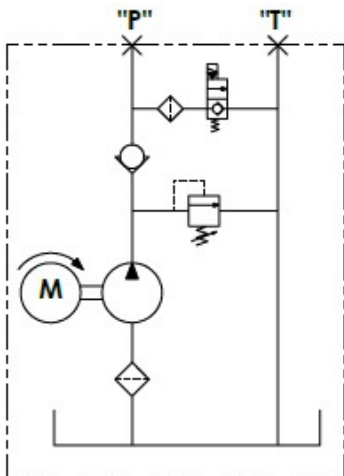

- VC1: CARTRIDGE RELIEF VALVE
- VC2: CARTRIDGE CHECK VALVE
- VC3: NC 2W2P SOLENOID VALVE
- VC4: VALVE PLUG

# UNIVERSAL MANIFOLD I

HYDRAULIC CIRCUIT 103A

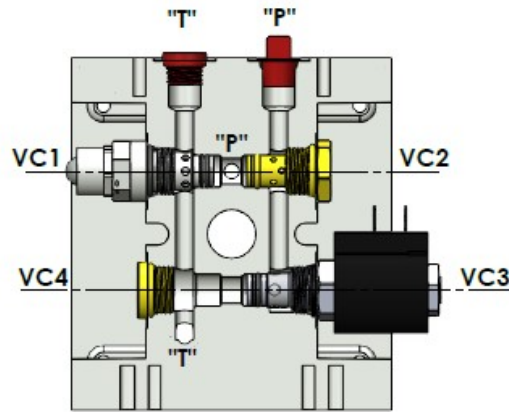
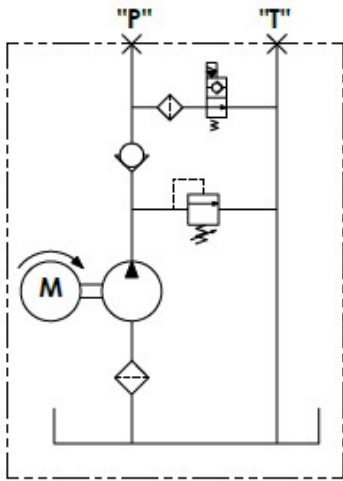

- VC1: CARTRIDGE RELIEF VALVE
- VC2: CARTRIDGE CHECK VALVE
- VC3: NO 2W2P SOLENOID VALVE
- VC4: VALVE PLUG

HYDRAULIC CIRCUIT 104A

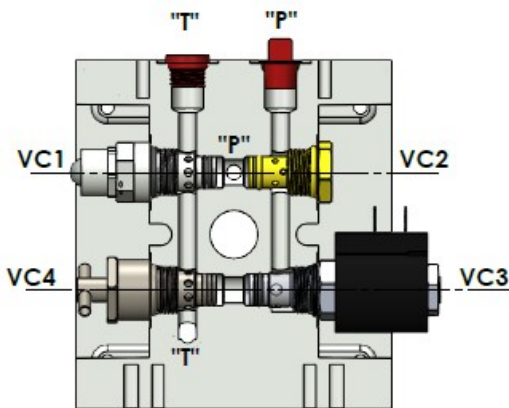
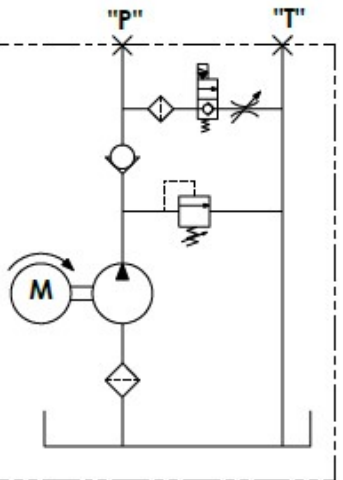

- VC1: CARTRIDGE RELIEF VALVE
- VC2: CARTRIDGE CHECK VALVE
- VC3: NC 2W2P SOLENOID VALVE
- VC4: ADJUSTABLE FLOW CONTROL VALVE

HYDRAULIC CIRCUIT 104B

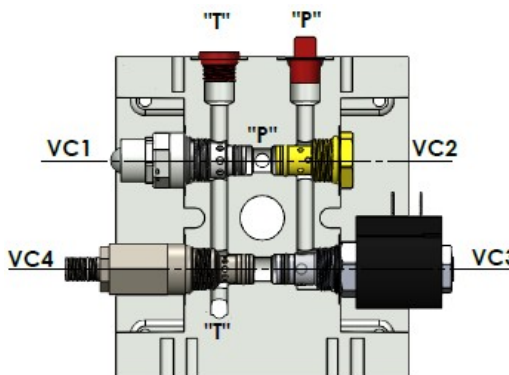
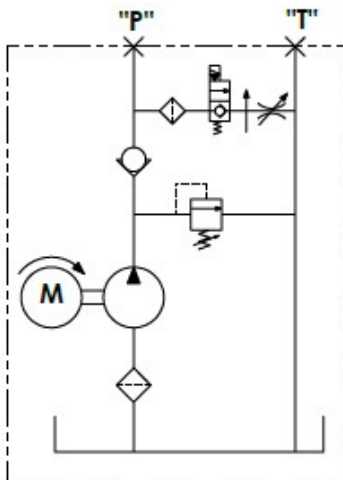

- VC1: CARTRIDGE RELIEF VALVE
- VC2: CARTRIDGE CHECK VALVE
- VC3: NC 2W2P SOLENOID VALVE
- VC4: PRESSURE COMPENSATED ADJUSTABLE FLOW CONTROL VALVE



# UNIVERSAL MANIFOLD I

HYDRAULIC CIRCUIT 105

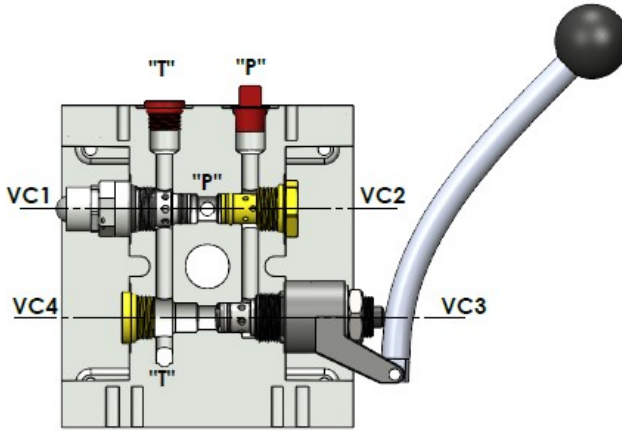
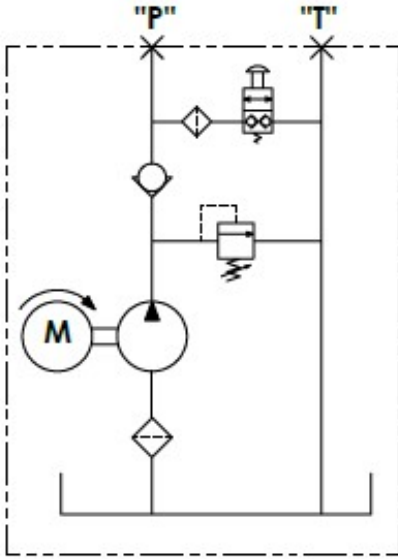

- VC1:** CARTRIDGE RELIEF VALVE
- VC2:** CARTRIDGE CHECK VALVE
- VC3:** MANUAL LOWERING VALVE
- VC4:** VALVE PLUG

HYDRAULIC CIRCUIT 106

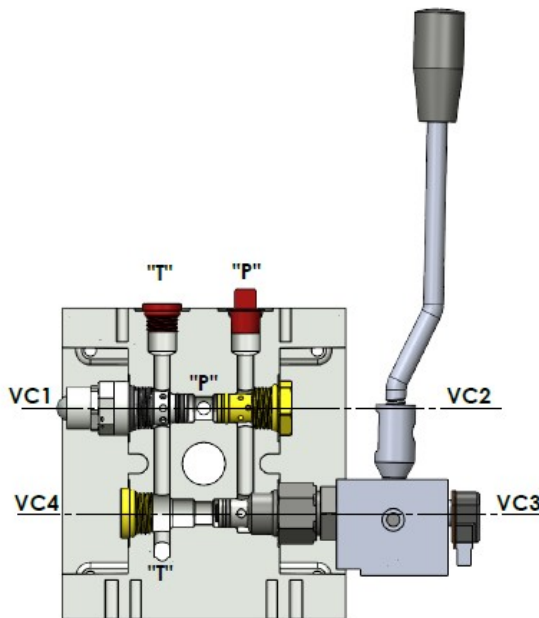
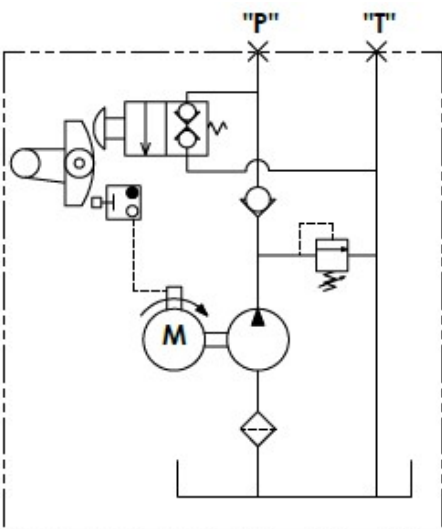

- VC1:** CARTRIDGE RELIEF VALVE
- VC2:** CARTRIDGE CHECK VALVE
- VC3:** MANUAL OPERATE POWER UP, GRAVITY DOWN VALVE
- VC4:** VALVE PLUG

# UNIVERSAL MANIFOLD II

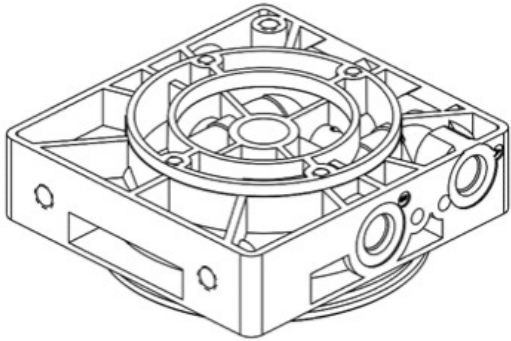

## OVERVIEW

Universal Manifold II (UM-II) is primarily used for both single and double acting applications

## HYDRAULIC CIRCUITS

108, 109, 110, 111, 114, 114A, 114B, 114C, 114D, 115\*

## OUTLET

"A" & "B" Port SAE #6 ORB 9/16-18

### HYDRAULIC CIRCUIT 108

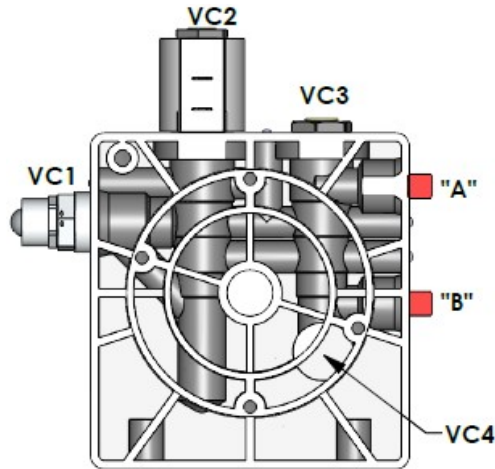
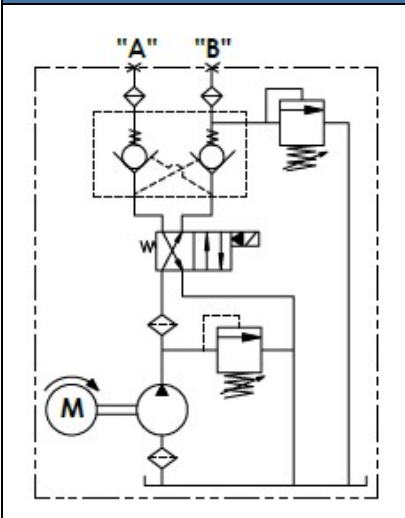

- VC1:** CARTRIDGE RELIEF VALVE
- VC2:** 4W2P DIRECTION VALVE
- VC3:** DUAL PILOT OPERATED CHECK VALVE
- VC4:** OPTIONAL 2ND RELIEF VALVE

### HYDRAULIC CIRCUIT 110

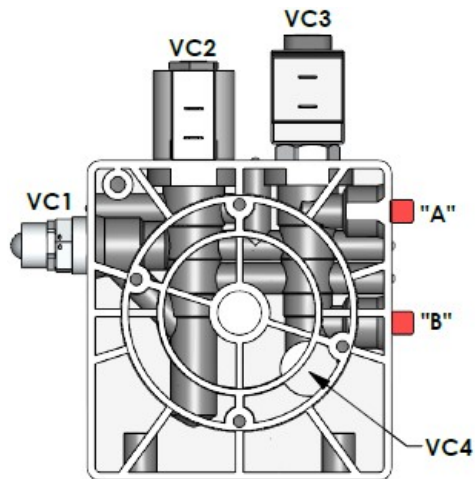
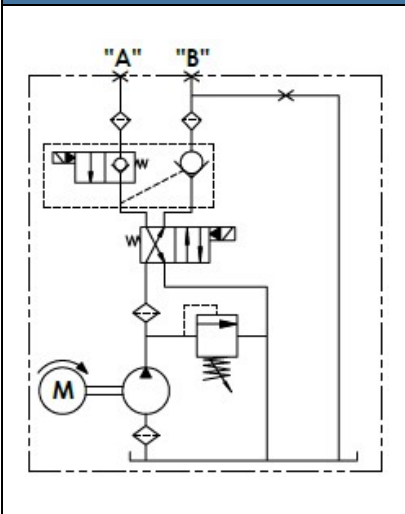

- VC1:** CARTRIDGE RELIEF VALVE
- VC2:** 4W2P DIRECTION VALVE
- VC3:** KT1 PROPRIETARY LOAD HOLDING VALVE
- VC4:** PLUG

**UNIVERSAL MANIFOLD II**

**HYDRAULIC CIRCUIT 111**

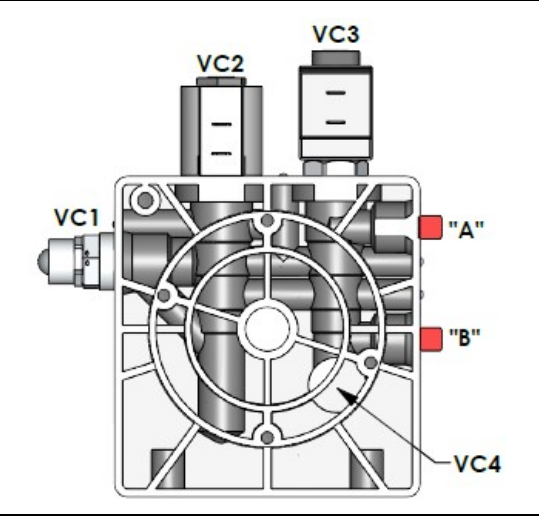
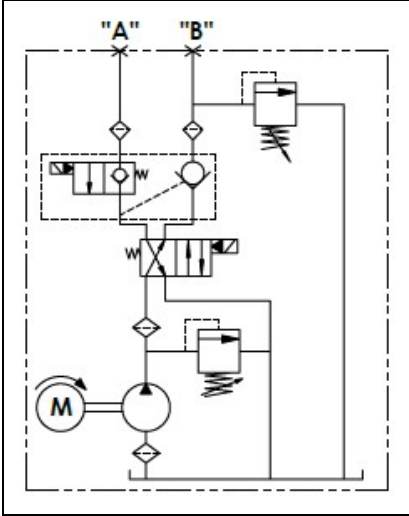

- VC1:** CARTRIDGE RELIEF VALVE
- VC2:** 4W2P DIRECTION VALVE
- VC3:** KTI PROPRIETARY LOAD HOLDING VALVE
- VC4:** 2ND RELIEF VALVE

**HYDRAULIC CIRCUIT 114**

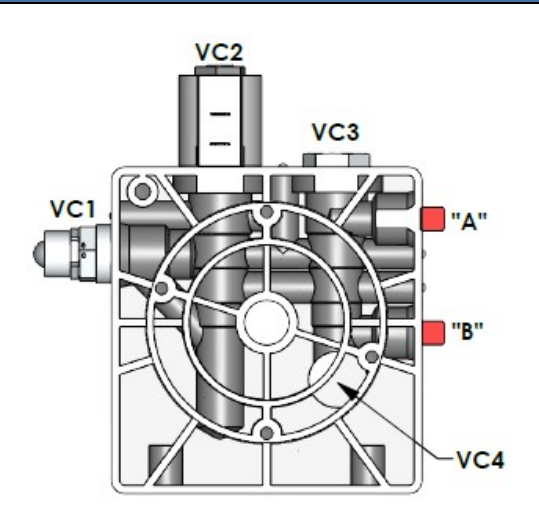
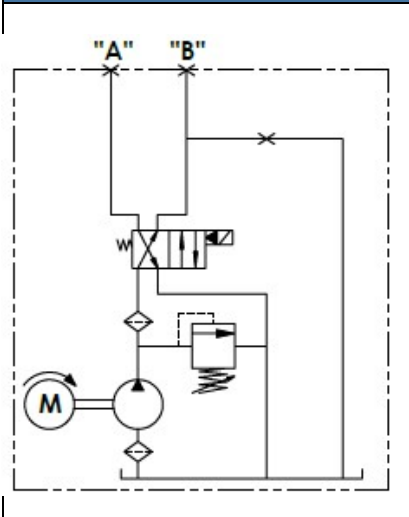

- VC1:** CARTRIDGE RELIEF VALVE
- VC2:** 4W2P DIRECTION VALVE
- VC3:** 4W CAVITY PLUG
- VC4:** PLUG

**HYDRAULIC CIRCUIT 114A**

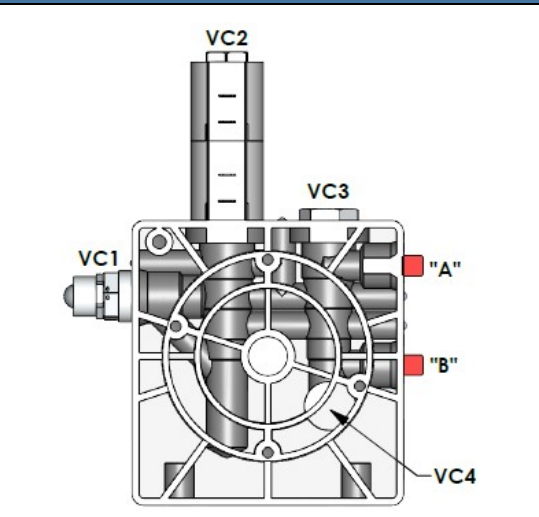
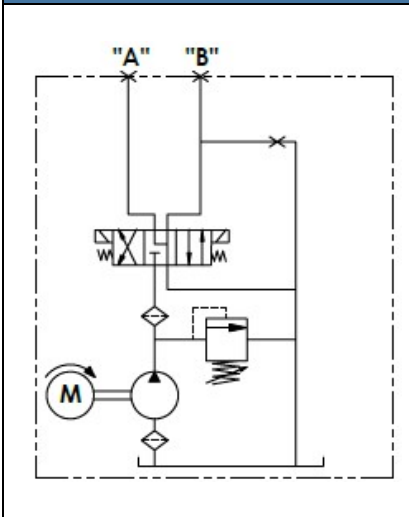

- VC1:** CARTRIDGE RELIEF VALVE
- VC2:** 4W3P MOTOR CENTER VALVE
- VC3:** 4W CAVITY PLUG
- VC4:** PLUGGED

# UNIVERSAL MANIFOLD II

HYDRAULIC CIRCUIT 114B

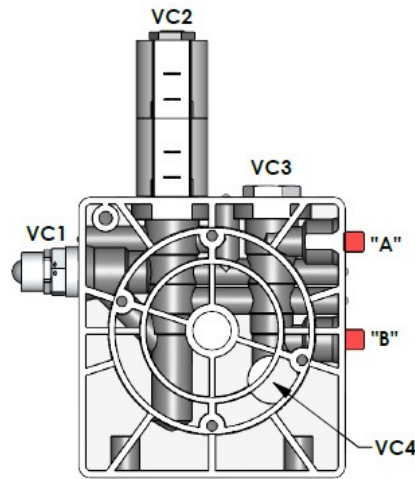
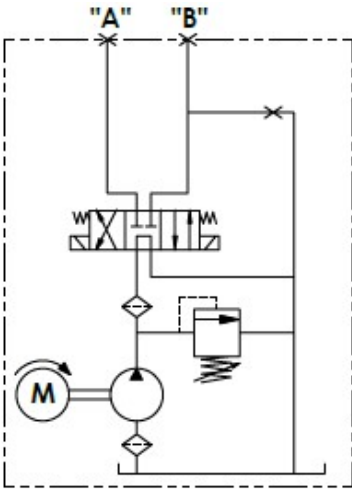

- VC1: CARTRIDGE RELIEF VALVE
- VC2: 4W3P TANDEM CENTER VALVE
- VC3: 4W CAVITY PLUG
- VC4: PLUGGED

HYDRAULIC CIRCUIT 114C

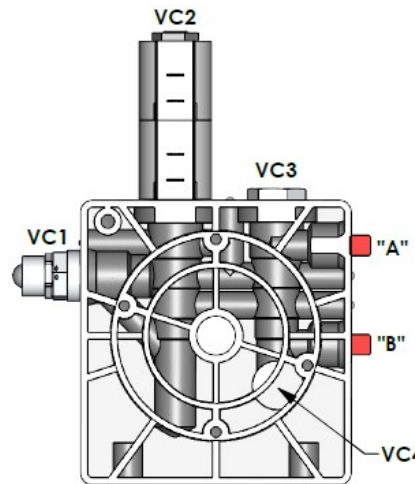
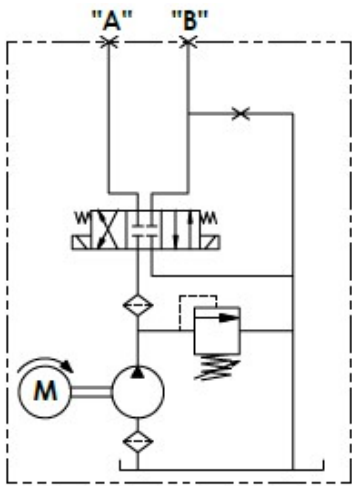

- VC1: CARTRIDGE RELIEF VALVE
- VC2: 4W3P CLOSE CENTER VALVE
- VC3: 4W CAVITY PLUG
- VC4: PLUGGED

HYDRAULIC CIRCUIT 114D

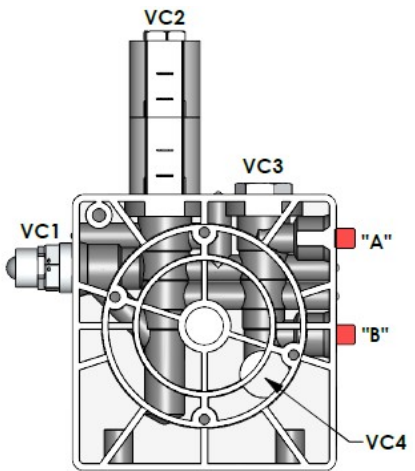
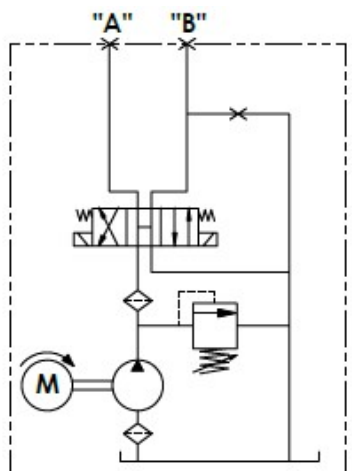

- VC1: CARTRIDGE RELIEF VALVE
- VC2: 4W3P MOTOR CENTER VALVE
- VC3: 4W CAVITY PLUG
- VC4: PLUGGED

**115 MANIFOLD**

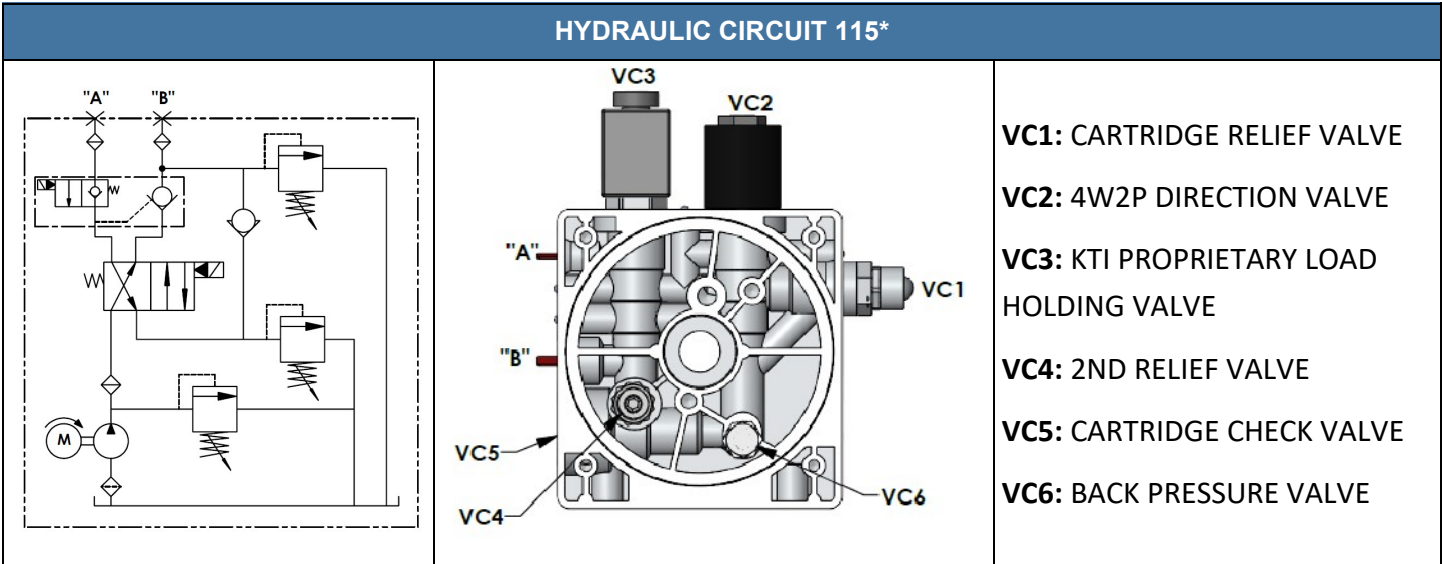

\* HYDRAULIC CIRCUIT 115 IS SEPARATE MANIFOLD DESIGN FROM UM-II



# UNIVERSAL MANIFOLD III

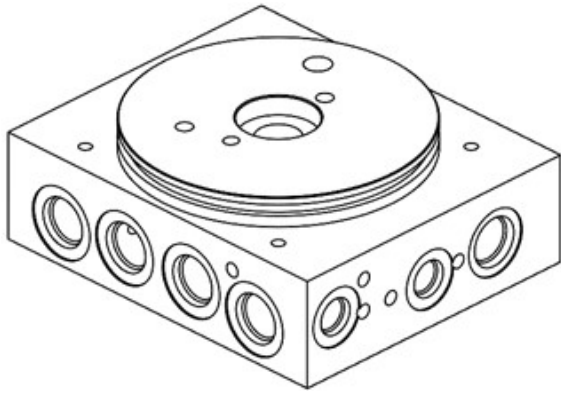

## OVERVIEW

Universal Manifold III (UM-III) is primarily used for single and double acting applications. Can integrate any two circuits from UM I and UM II.

## HYDRAULIC CIRCUITS

208, 211, 215, 216, 217

## OUTLET

"A", "B", "A1", & "B1" Ports SAE #6 ORB 9/16-18

### HYDRAULIC CIRCUIT 208

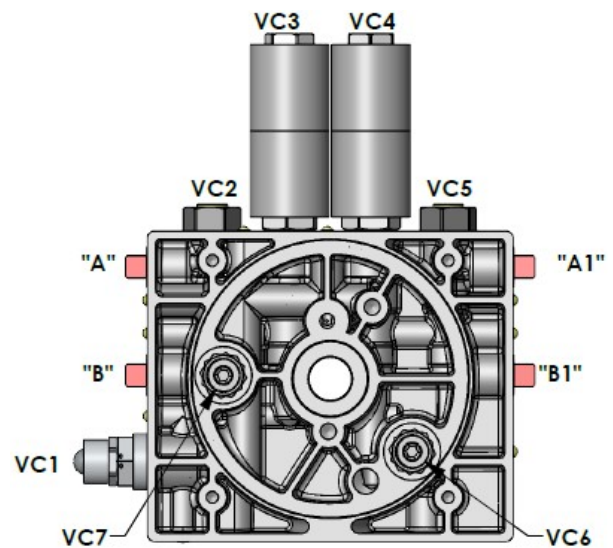
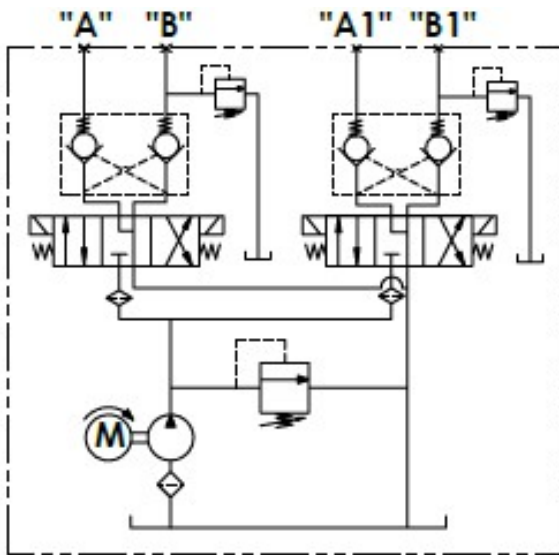

**VC 1:** CARTRIDGE RELIEF VALVE

**VC 2:** DUAL PILOT OPERATED CHECK VALVE

**VC 3:** 4W3P MOTOR CENTER VALVE

**VC 4:** 4W3P MOTOR CENTER VALVE

**VC 5:** DUAL PILOT OPERATED CHECK VALVE

**VC 6:** 2ND RELIEF VALVE

**VC 7:** 2ND RELIEF VALVE

# UNIVERSAL MANIFOLD III

HYDRAULIC CIRCUIT 211

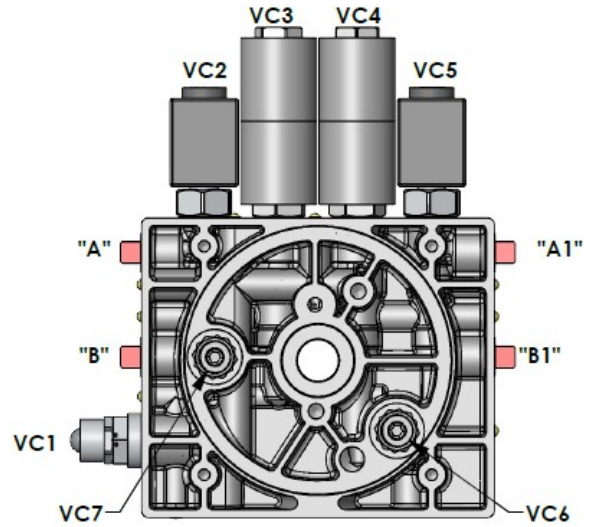
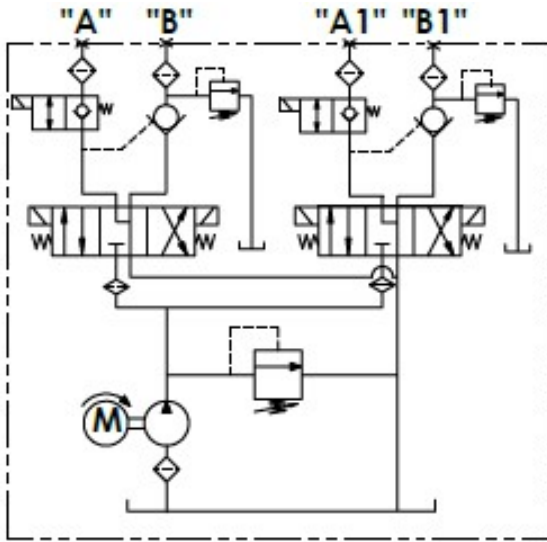

- VC 1:** CARTRIDGE RELIEF VALVE      **VC 2:** KTI PROPRIETARY LOAD HOLDING VALVE  
**VC 3:** 4W3P MOTOR CENTER, CARTRIDGE SOLENOID VALVE  
**VC 4:** 4W3P MOTOR CENTER, CARTRIDGE SOLENOID VALVE  
**VC 5:** KTI PROPRIETARY LOAD HOLDING VALVE  
**VC 6:** 2ND RELIEF VALVE      **VC 7:** 2ND RELIEF VALVE

HYDRAULIC CIRCUIT 215

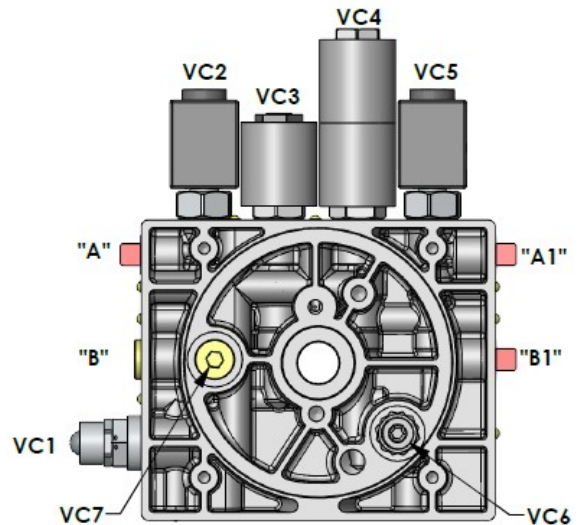
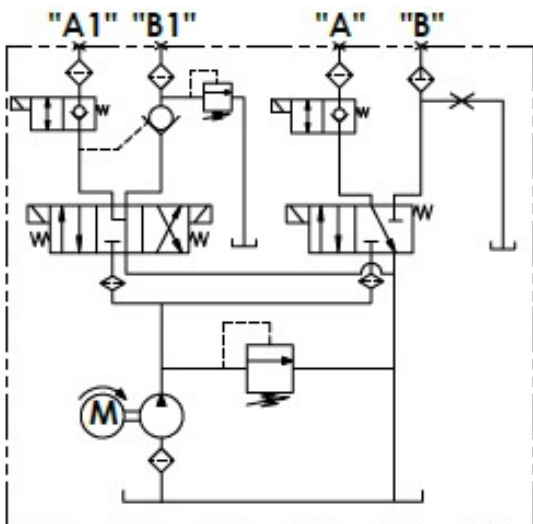

- VC 1:** CARTRIDGE RELIEF VALVE      **VC 2:** NC 2 WAY VALVE  
**VC 3:** 4W2P SPOOL TYPE CARTRIDGE SOLENOID VALVE  
**VC 4:** 4W3P MOTOR CENTER, CARTRIDGE SOLENOID VALVE  
**VC 5:** KTI PROPRIETARY LOAD HOLDING VALVE  
**VC 6:** 2ND RELIEF VALVE      **VC 7:** PLUG

# UNIVERSAL MANIFOLD III

## HYDRAULIC CIRCUIT 216

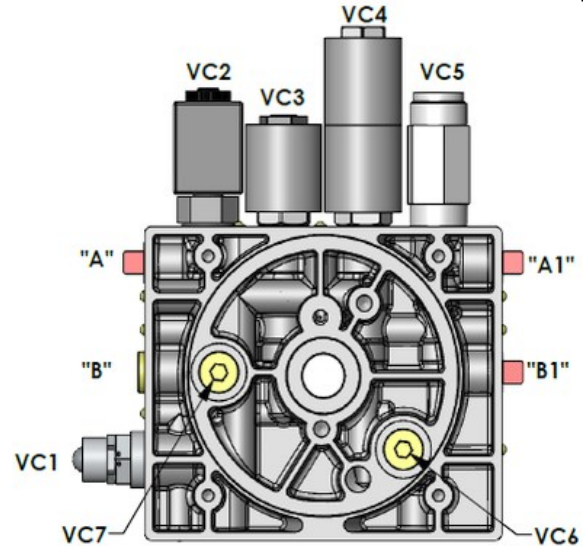
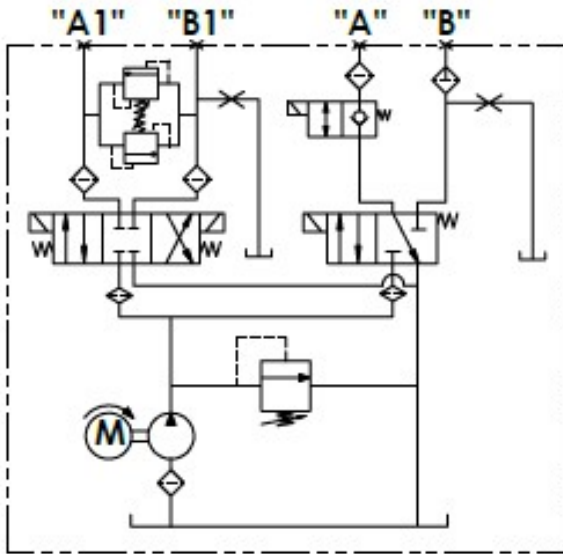

**VC 1:** CARTRIDGE RELIEF VALVE

**VC 2:** NC 2WAY VALVE

**VC 3:** 4W2P SPOOL TYPE CARTRIDGE SOLENOID VALVE

**VC 4:** 4W3P CLOSE CENTER SPOOL TYPE CARTRIDGE SOLENOID VALVE

**VC 5:** ADJUSTABLE DIRECTIONAL BI-DIRECTIONAL RELIEF VALVE

**VC 6:** PLUG

**VC 7:** PLUG

# UNIVERSAL MANIFOLD III

HYDRAULIC CIRCUIT 217

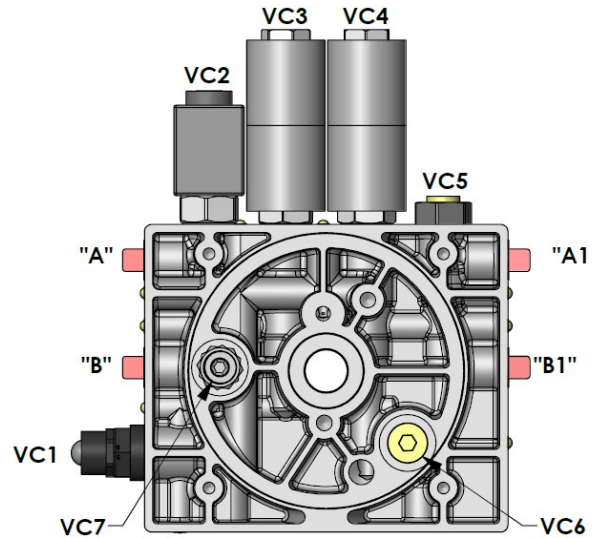
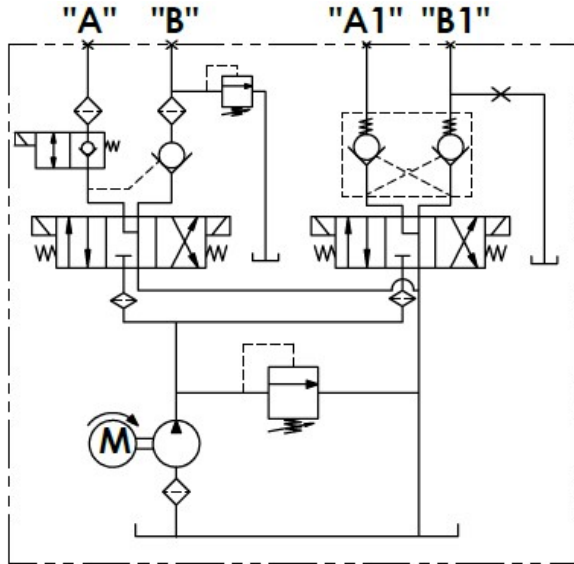

**VC 1: CARTRIDGE RELIEF VALVE**

**VC 2: KTI PROPRIETARY LOAD HOLDING VALVE**

**VC 3: 4W3P MOTOR CENTER, CARTRIDGE SOLENOID VALVE**

**VC 4: 4W3P MOTOR CENTER, CARTRIDGE SOLENOID VALVE**

**VC 5: DUAL PILOT OPERATED CHECK VALVE**

**VC 6: PLUG**

**VC 7: 2ND RELIEF VALVE**

# MANIFOLD WITH D03 MOUNT

## OVERVIEW

Manifold with D03 mount on top allows minimizing leakage point and reducing cost by eliminating the need for mounting hardware and O-rings. The manifold also comes with #8 valve cavities for check and relief valves.

## OUTLET

"A" & "B" Port SAE #6 ORB 9/16-18

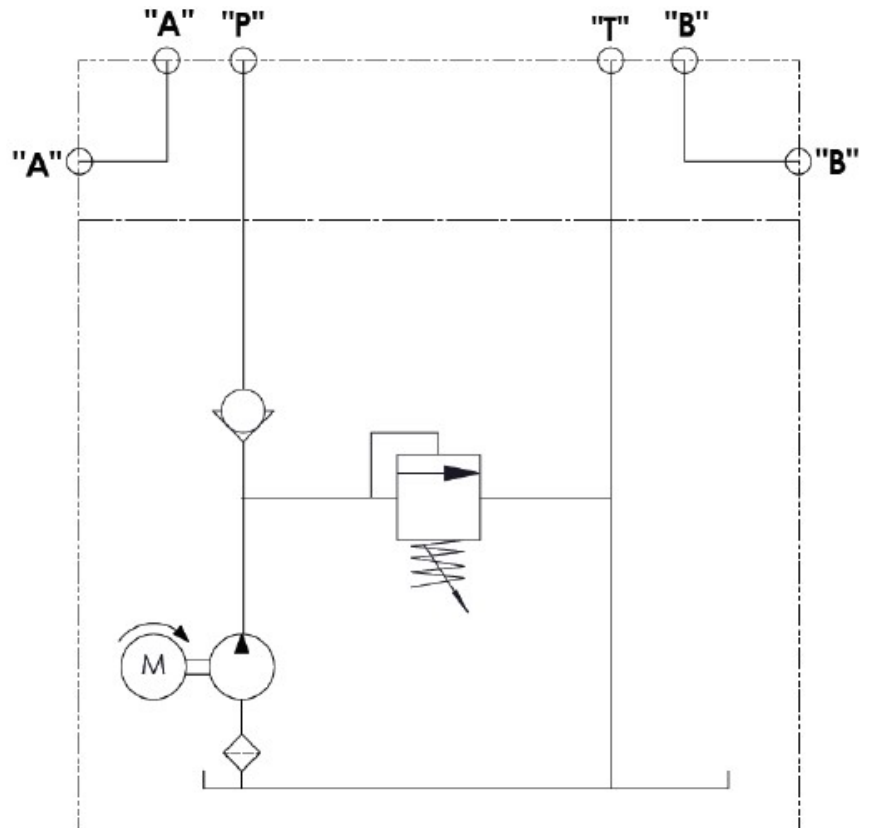
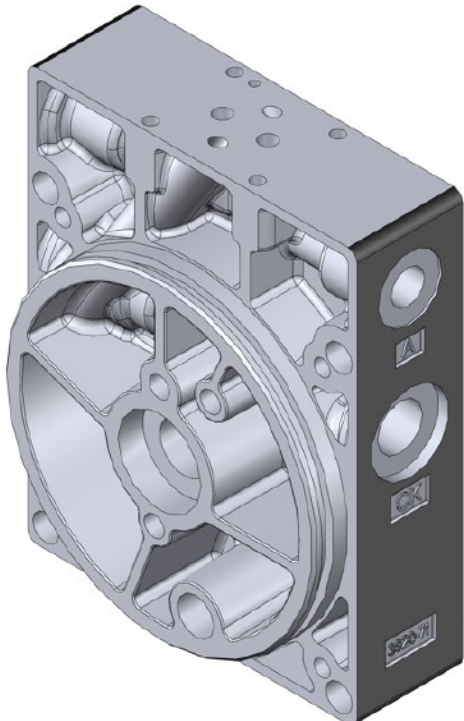



## POWER UNIT MODEL - UM I - Circuit 101

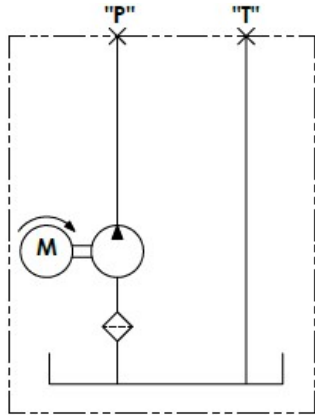

Hydraulic Circuit 101

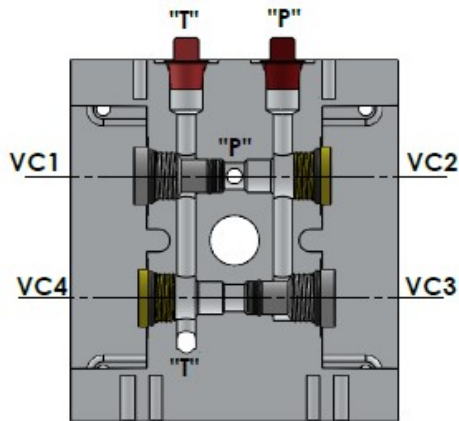

**CAVITY 1:** VALVE CAVITY PLUG

**CAVITY 2:** VALVE PLUG

**CAVITY 3:** VALVE CAVITY PLUG

**CAVITY 4:** VALVE PLUG

KTI Universal Manifold I. Most basic of all circuits.

No valves. "P" & "T" SAE #6 (9/16-18) O-ring ports

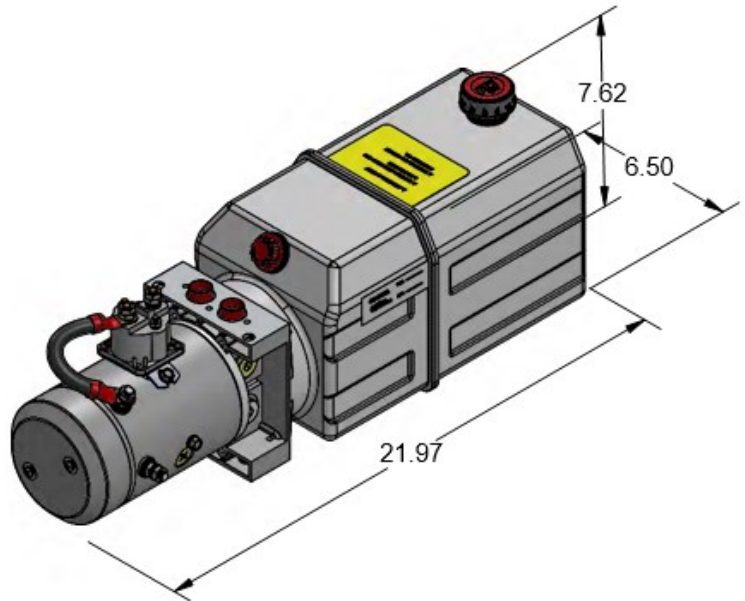

\* Dimensions are subject to change based on configuration

### AS SHOWN

**MOTOR** - 12V DC

**PUMP** - PL SERIES

**RESERVOIR** - 6 QT PLASTIC

## CONFIGURATION OPTIONS

### MOTOR

OD 3.0" 12V DC

OD 4.5" 12/24V DC

OD 5.0" 12/24V DC

1/2 HP - 5 HP AC

### PUMP

PL 0.6 - 6.0 (0.0384 - 0.3681 in<sup>3</sup>/r)

### RESERVOIR

STEEL - 1.5 QT - 7 GALLON

PLASTIC - 3 QT - 14 QT

### MOUNTING

HORIZONTAL

VERTICAL

### MISC

DC START SWITCH

## POWER UNIT MODEL - UM I - Circuit 102

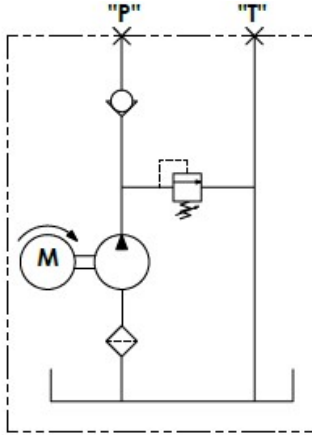

Hydraulic Circuit 102

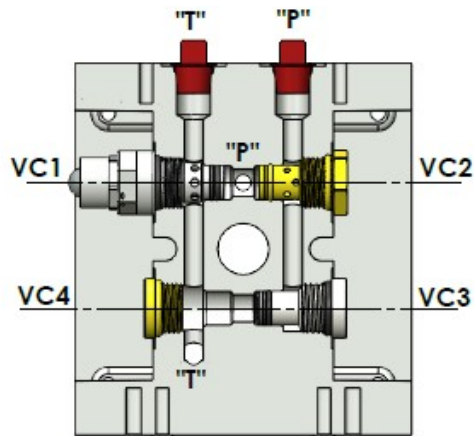

- CAVITY 1: CARTRIDGE RELIEF VALVE
- CAVITY 2: CARTRIDGE CHECK VALVE
- CAVITY 3: VALVE CAVITY PLUG
- CAVITY 4: VALVE PLUG

KTI Universal Manifold I with cartridge check and cartridge relief valve.

Base "P" & "T" power unit

"P" & "T" SAE #6 (9/16-18) O-ring ports.

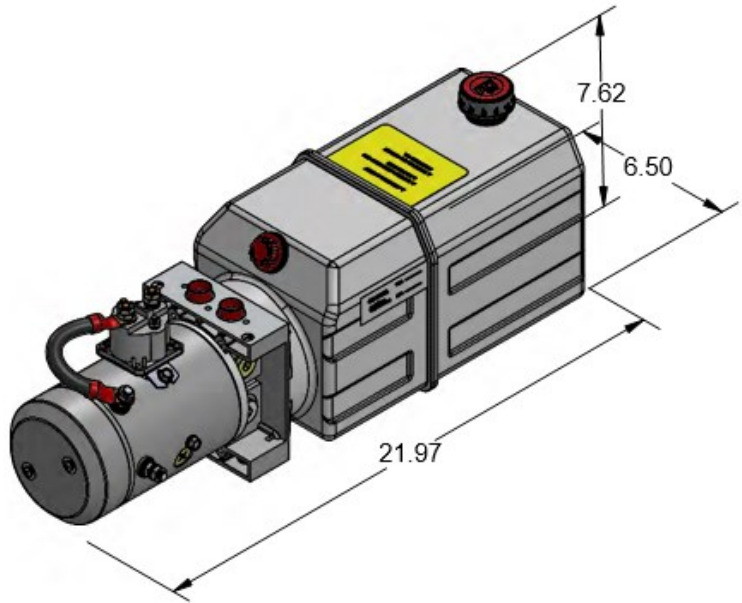

\* Dimensions are subject to change based on configuration

### AS SHOWN

- MOTOR - 12V DC
- PUMP - PL SERIES
- RESERVOIR - 6 QT PLASTIC

## CONFIGURATION OPTIONS

### MOTOR

- OD 3.0" 12V DC
- OD 4.5" 12/24V DC
- OD 5.0" 12/24V DC
- 1/2 HP - 5 HP AC

### PUMP

- PL 0.6 - 6.0 (0.0384 - 0.3681 in<sup>3</sup>/r)

### RESERVOIR

- STEEL - 1.5 QT - 7 GALLON
- PLASTIC - 3 QT - 14 QT

### MOUNTING

- HORIZONTAL
- VERTICAL

### MISC

- DC START SWITCH

## POWER UNIT MODEL - UM I - Circuit 103

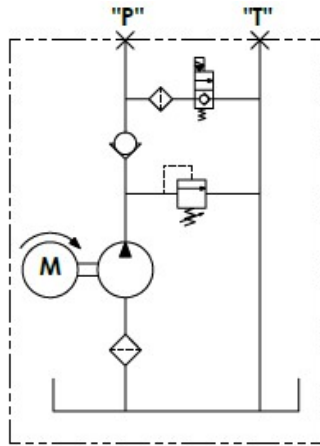

Hydraulic Circuit 103

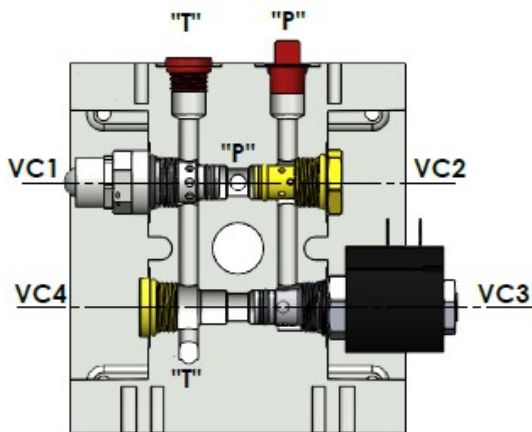

**CAVITY 1:** CARTRIDGE RELIEF VALVE

**CAVITY 2:** CARTRIDGE CHECK VALVE

**CAVITY 3:** NC 2W2P SOLENOID VALVE

**CAVITY 4:** VALVE PLUG

KTI Universal Manifold I with cartridge relief valve, cartridge check valve, cartridge NC 2 way poppet valve.

Base lift, check, and lowering circuit power unit.

"P" & "T" SAE #6 (9/16-18) O-ring ports.

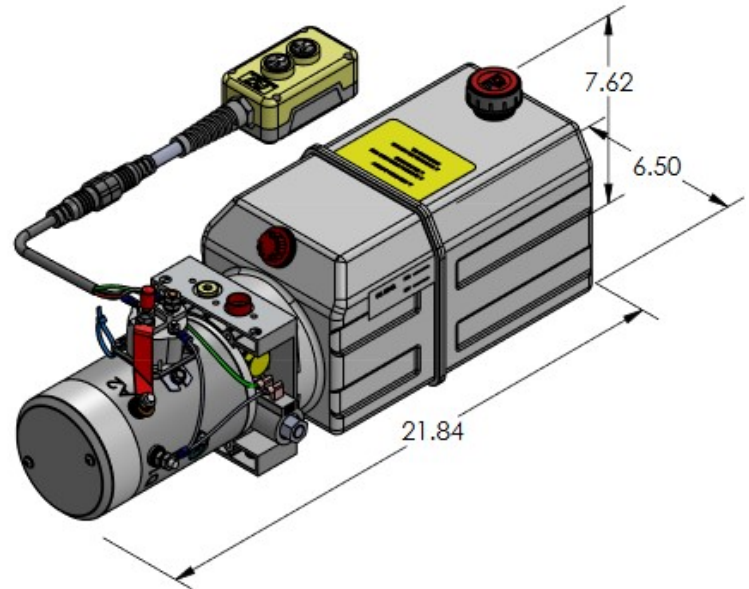

\* Dimensions are subject to change based on configuration

### AS SHOWN

**MOTOR** - 12V DC

**PUMP** - PL SERIES

**RESERVOIR** - 6 QT PLASTIC

2 BUTTON REMOTE PENDANT WITH QD

## CONFIGURATION OPTIONS

### MOTOR

OD 3.0" 12V DC

OD 4.5" 12/24V DC

OD 5.0" 12/24V DC

1/2 HP - 5 HP AC

### PUMP

PL 0.6 - 6.0 (0.0384 - 0.3681 in<sup>3</sup>/r)

### RESERVOIR

STEEL - 1.5 QT - 7 GALLON

PLASTIC - 3 QT - 14 QT

### MOUNTING

HORIZONTAL

VERTICAL

### MISC

DC START SWITCH

REMOTE PENDANT

## POWER UNIT MODEL - UM I - Circuit 103A

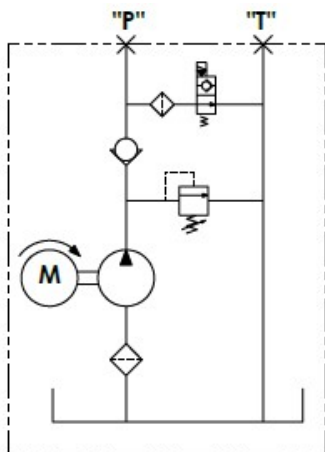

Hydraulic Circuit 103A

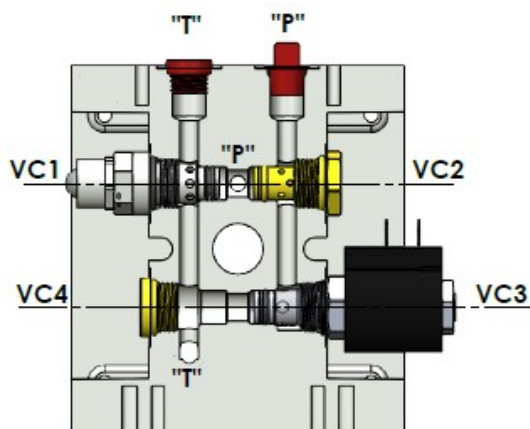

- CAVITY 1: CARTRIDGE RELIEF VALVE
- CAVITY 2: CARTRIDGE CHECK VALVE
- CAVITY 3: NO 2W2P SOLENOID VALVE
- CAVITY 4: VALVE PLUG

KTi Universal Manifold I with cartridge relief valve, cartridge check valve, cartridge NO 2 way poppet valve.

Base lift, check, and lowering circuit power unit.

"P" & "T" SAE #6 (9/16-18) O-ring ports.

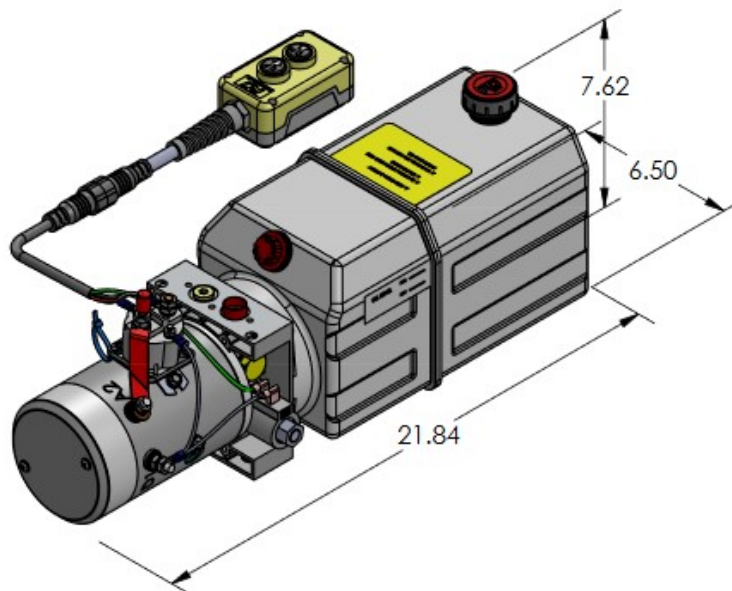

\* Dimensions are subject to change based on configuration

### AS SHOWN

- MOTOR - 12V DC
- PUMP - PL SERIES
- RESERVOIR - 6 QT PLASTIC
- 2 BUTTON REMOTE PENDANT WITH QUICK DISC.

## CONFIGURATION OPTIONS

### MOTOR

- OD 3.0" 12V DC
- OD 4.5" 12/24V DC
- OD 5.0" 12/24V DC
- 1/2 HP - 5 HP AC

### PUMP

- PL 0.6 - 6.0 (0.0384 - 0.3681 in<sup>3</sup>/r)

### RESERVOIR

- STEEL - 1.5 QT - 7 GALLON
- PLASTIC - 3 QT - 14 QT

### MOUNTING

- HORIZONTAL
- VERTICAL

### MISC

- DC START SWITCH
- REMOTE PENDANT

## POWER UNIT MODEL - UM I - Circuit 104A

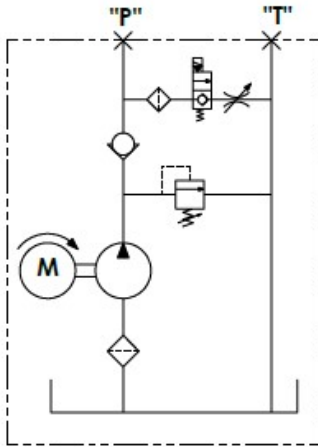

Hydraulic Circuit 104A

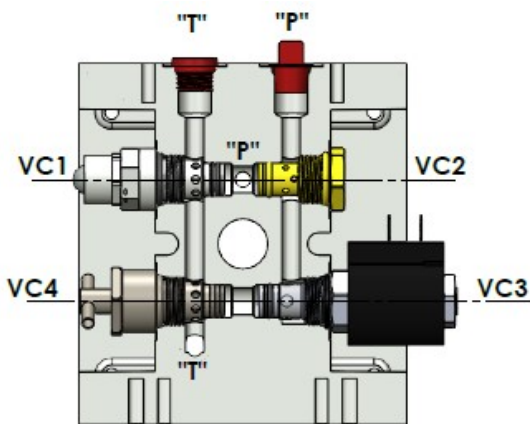

- CAVITY 1: CARTRIDGE RELIEF VALVE
- CAVITY 2: CARTRIDGE CHECK VALVE
- CAVITY 3: NC 2W2P SOLENOID VALVE
- CAVITY 4: ADJUSTABLE FLOW CONTROL VALVE

KTi Universal Manifold I with cartridge relief valve, cartridge check valve, cartridge NC 2 way poppet valve, and adjustable flow control valve.

Base lift, check, and lowering with adjustable return flow power unit.

"P" & "T" SAE #6 (9/16-18) O-ring ports.

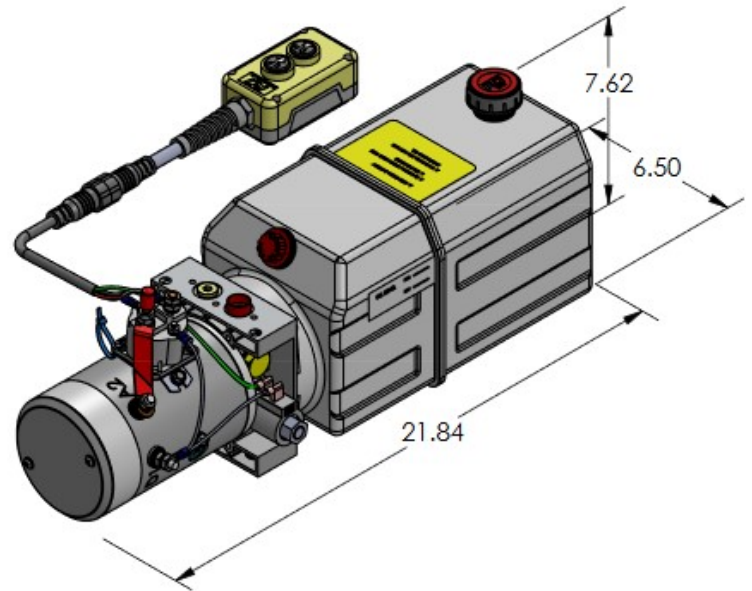

\* Dimensions are subject to change based on configuration

### AS SHOWN

- MOTOR - 12V DC
- PUMP - PL SERIES
- RESERVOIR - 6 QT PLASTIC
- 2 BUTTON REMOTE PENDANT WITH QUICK DISC.

## CONFIGURATION OPTIONS

### MOTOR

- OD 3.0" 12V DC
- OD 4.5" 12/24V DC
- OD 5.0" 12/24V DC
- 1/2 HP - 5 HP AC

### PUMP

- PL 0.6 - 6.0 (0.0384 - 0.3681 in<sup>3</sup>/r)

### RESERVOIR

- STEEL - 1.5 QT - 7 GALLON
- PLASTIC - 3 QT - 14 QT

### MOUNTING

- HORIZONTAL
- VERTICAL

### MISC

- DC START SWITCH
- REMOTE PENDANT



## POWER UNIT MODEL - UM I - Circuit 104B

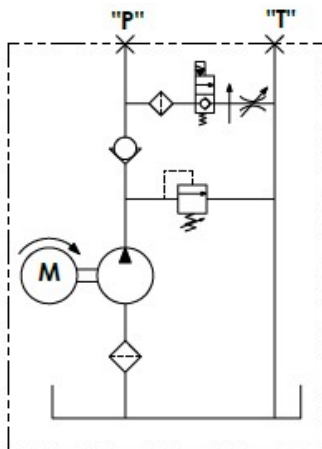

Hydraulic Circuit 104B

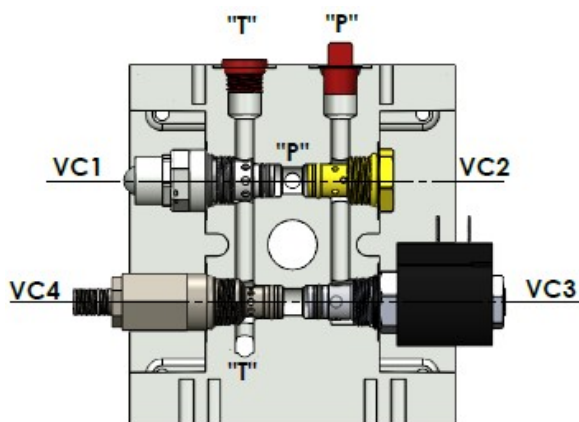

**CAVITY 1:** CARTRIDGE RELIEF VALVE

**CAVITY 2:** CARTRIDGE CHECK VALVE

**CAVITY 3:** NC 2W2P SOLENOID VALVE

**CAVITY 4:** PRESSURE COMPENSATED ADJUSTABLE FLOW CONTROL VALVE

KTi Universal Manifold I with cartridge relief valve, cartridge check valve, cartridge NC 2 way valve, and pressure compensated adjustable flow control valve.

Base lift, check, and lowering with fully adjustable pressure compensated return flow power unit.

"P" & "T" SAE #6 (9/16-18) O-ring ports.

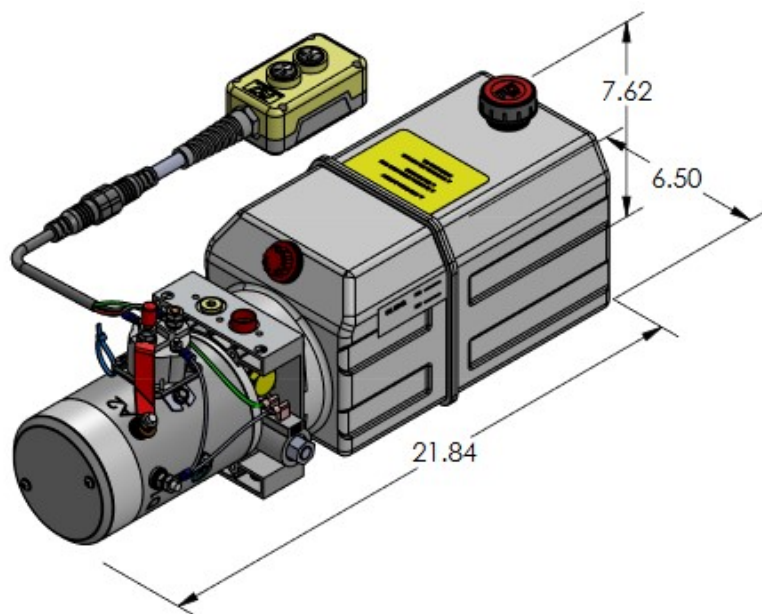

\* Dimensions are subject to change based on configuration

### AS SHOWN

**MOTOR** - 12V DC

**PUMP** - PL SERIES

**RESERVOIR** - 6 QT PLASTIC

2 BUTTON REMOTE PENDANT WITH QUICK DISC.

## CONFIGURATION OPTIONS

### MOTOR

OD 3.0" 12V DC

OD 4.5" 12/24V DC

OD 5.0" 12/24V DC

1/2 HP - 5 HP AC

### PUMP

PL 0.6 - 6.0 (0.0384 - 0.3681 in<sup>3</sup>/r)

### RESERVOIR

STEEL - 1.5 QT - 7 GALLON

PLASTIC - 3 QT - 14 QT

### MOUNTING

HORIZONTAL

VERTICAL

### MISC

DC START SWITCH

REMOTE PENDANT

## POWER UNIT MODEL - UM I - Circuit 105

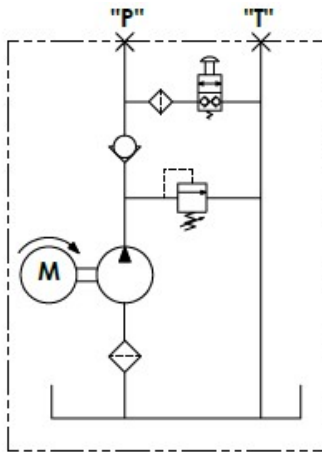

Hydraulic Circuit 105

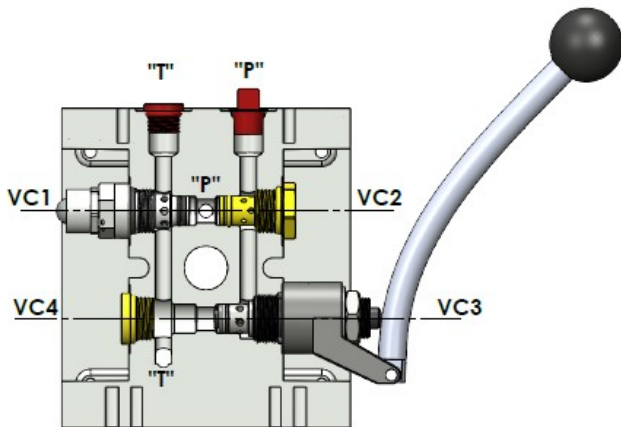

- CAVITY 1:** CARTRIDGE RELIEF VALVE
- CAVITY 2:** CARTRIDGE CHECK VALVE
- CAVITY 3:** MANUAL LOWERING VALVE
- CAVITY 4:** VALVE PLUG

KTi Universal Manifold I with cartridge relief valve, cartridge check valve, and manual operate NC 2 way valve.

Base lift, check, and manual lowering valve.

"P" & "T" SAE #6 (9/16-18) O-ring ports.

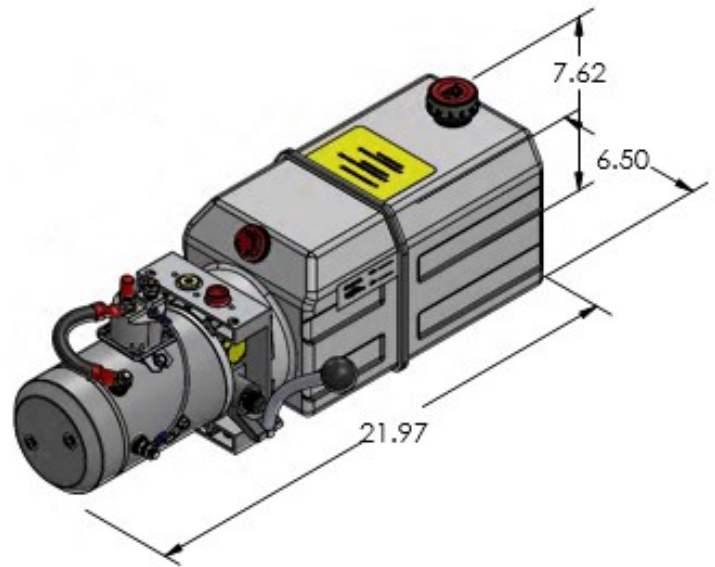

\* Dimensions are subject to change based on configuration

### AS SHOWN

- MOTOR** - 12V DC
- PUMP** - PL SERIES
- RESERVOIR** - 6 QT PLASTIC

## CONFIGURATION OPTIONS

### MOTOR

- OD 3.0" 12V DC
- OD 4.5" 12/24V DC
- OD 5.0" 12/24V DC
- 1/2 HP - 5 HP AC

### PUMP

- PL 0.6 - 6.0 (0.0384 - 0.3681 in<sup>3</sup>/r)

### RESERVOIR

- STEEL - 1.5 QT - 7 G
- PLASTIC - 3 QT - 14 QT

### MOUNTING

- HORIZONTAL
- VERTICAL

### MISC

- DC START SWITCH

## POWER UNIT MODEL - UM I - Circuit 106

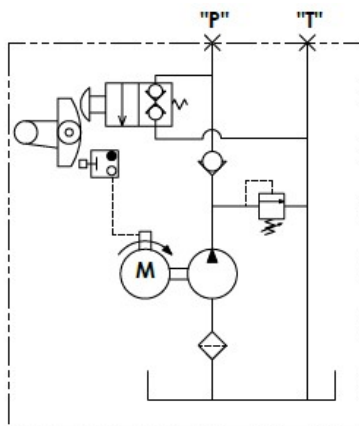

Hydraulic Circuit 106

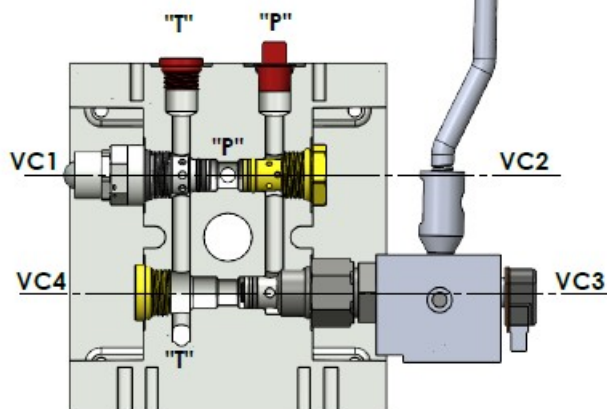

**CAVITY 1:** CARTRIDGE RELIEF VALVE

**CAVITY 2:** CARTRIDGE CHECK VALVE

**CAVITY 3:** MANUAL OPERATE POWER UP,  
GRAVITY DOWN VALVE

**CAVITY 4:** VALVE PLUG

KTi Universal Manifold I with cartridge relief valve, cartridge check valve, and manual operate power up, regulated gravity down.

Base lift, check, and manual three position valve.

"P" & "T" SAE #6 (9/16-18) O-ring ports.

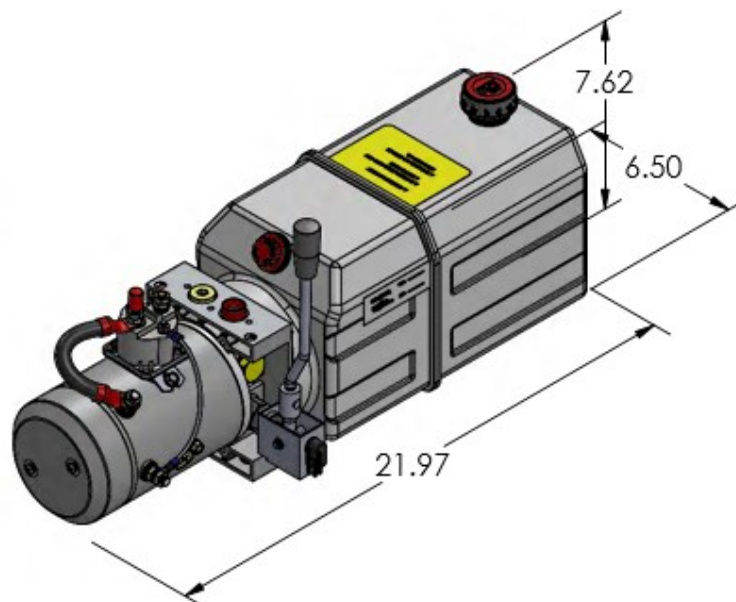

\* Dimensions are subject to change based on configuration

### AS SHOWN

**MOTOR** - 12V DC

**PUMP** - PL SERIES

**RESERVOIR** - 6 QT PLASTIC

## CONFIGURATION OPTIONS

### MOTOR

OD 3.0" 12V DC

OD 4.5" 12/24V DC

OD 5.0" 12/24V DC

1/2 HP - 5 HP AC

### PUMP

PL 0.6 - 6.0 (0.0384 - 0.3681 in<sup>3</sup>/r)

### RESERVOIR

STEEL - 1.5 QT - 7 G

PLASTIC - 3 QT - 14 QT

### MOUNTING

HORIZONTAL

VERTICAL

### MISC

DC START SWITCH

## POWER UNIT MODEL - UM II - Circuit 108

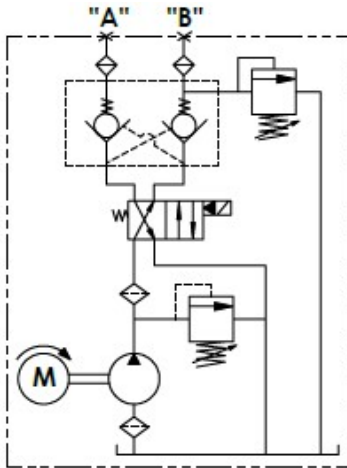

**Hydraulic Circuit 108  
(Optional 2nd RV)**

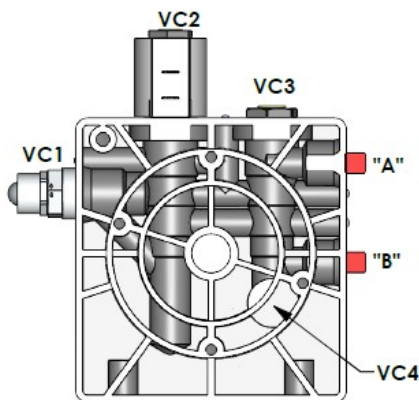

- CAVITY 1:** CARTRIDGE RELIEF VALVE
- CAVITY 2:** 4W2P DIRECTION VALVE
- CAVITY 3:** DUAL PILOT OPERATED CHECK VALVE
- CAVITY 4:** (OPTIONAL 2ND RELIEF VALVE)

KTI Universal Manifold II with cartridge relief valve, 4w2p valve, dual pilot operated check valve, and optional secondary relief valve.

Double acting circuit for power up, power down operation.

"A" & "B" SAE #6 (9/16-18) O-ring ports.

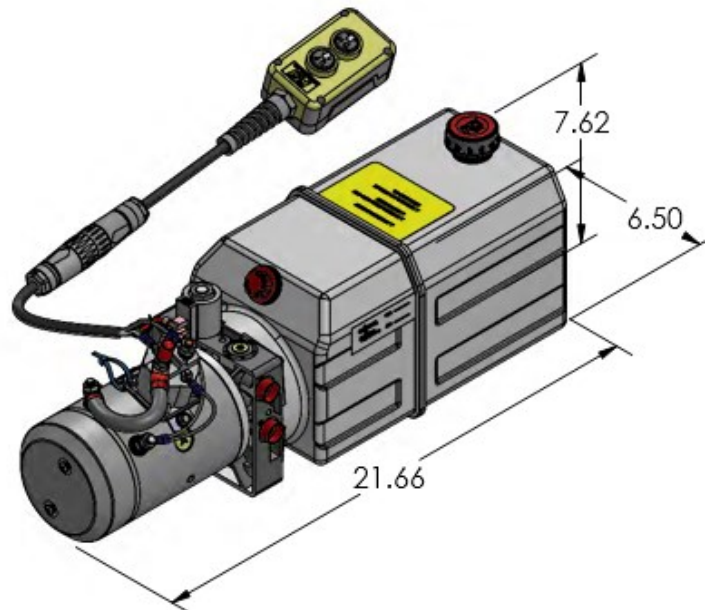

\* Dimensions are subject to change based on configuration

### AS SHOWN

- MOTOR** - 12V DC
- PUMP** - PL SERIES
- RESERVOIR** - 6 QT PLASTIC
- 2 BUTTON REMOTE PENDANT WITH QUICK DISC.

## CONFIGURATION OPTIONS

### MOTOR

- OD 3.0" 12V DC
- OD 4.5" 12/24V DC
- OD 5.0" 12/24V DC
- 1/2 HP - 5 HP AC

### PUMP

- PL 0.6 - 6.0 (0.0384 - 0.3681 in<sup>3</sup>/r)

### RESERVOIR

- STEEL - 1.5 QT - 7 G
- PLASTIC - 3 QT - 14 QT

### MOUNTING

- HORIZONTAL
- VERTICAL

### MISC

- DC START SWITCH
- REMOTE PENDANT

## POWER UNIT MODEL - UM II - Circuit 109

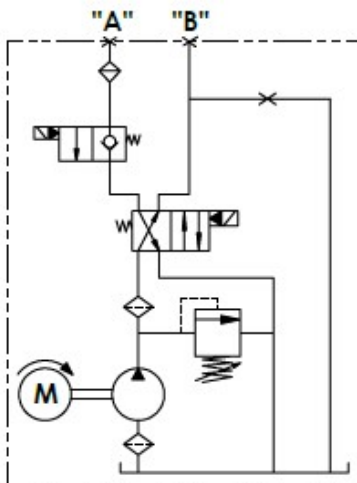

Hydraulic Circuit 109

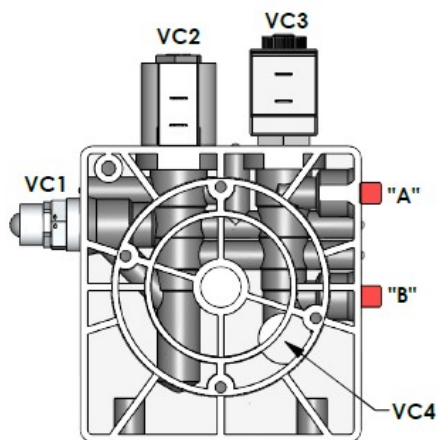

**CAVITY 1:** CARTRIDGE RELIEF VALVE

**CAVITY 2:** 4W2P DIRECTION VALVE

**CAVITY 3:** NC 2W VALVE

**CAVITY 4:** PLUG

KTI Universal Manifold II with cartridge relief valve, 4w2p valve, and NC w2 valve.

Double acting circuit for power up, power down operation.

"A" & "B" SAE #6 (9/16-18) O-ring ports.

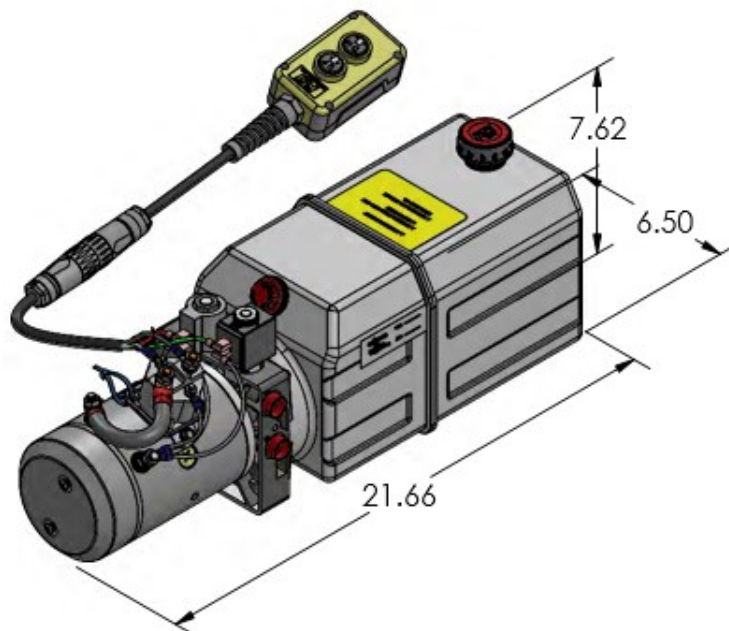

\* Dimensions are subject to change based on configuration

### AS SHOWN

**MOTOR** - 12V DC

**PUMP** - PL SERIES

**RESERVOIR** - 6 QT PLASTIC

2 BUTTON REMOTE PENDANT WITH QUICK DISC.

## CONFIGURATION OPTIONS

### MOTOR

OD 3.0" 12V DC

OD 4.5" 12/24V DC

### PUMP

PL 0.6 - 6.0 (0.0384 - 0.3681 in<sup>3</sup>/r)

### RESERVOIR

STEEL - 1.5 QT - 7 G

PLASTIC - 3 QT - 14 QT

### MOUNTING

HORIZONTAL

VERTICAL

### MISC

DC START SWITCH

REMOTE PENDANT



## POWER UNIT MODEL - UM II - Circuit 110

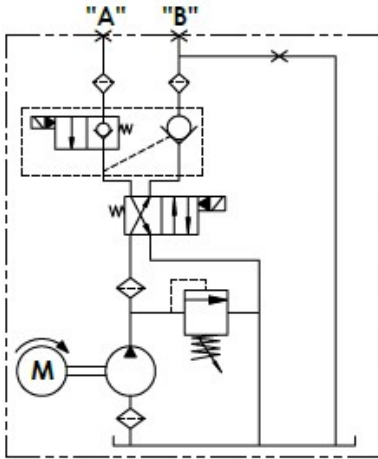

Hydraulic Circuit 110

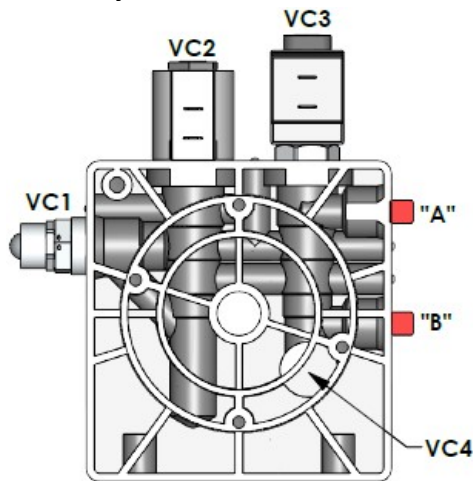

- CAVITY 1:** CARTRIDGE RELIEF VALVE
- CAVITY 2:** 4W2P DIRECTION VALVE
- CAVITY 3:** KTI PROPRIETARY LOAD HOLDING VALVE
- CAVITY 4:** PLUG

KT Universal Manifold II with cartridge relief valve, 4w2p valve, and KT proprietary load holding valve.

Double acting circuit for power up, power down operation.

"A" & "B" SAE #6 (9/16-18) O-ring ports.

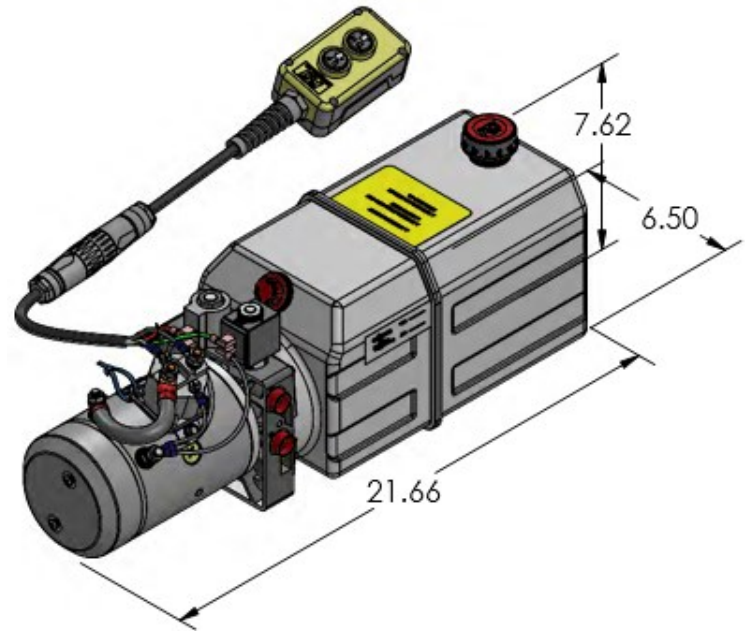

\* Dimensions are subject to change based on configuration

### AS SHOWN

- MOTOR** - 12V DC
- PUMP** - PL SERIES
- RESERVOIR** - 6 QT PLASTIC
- 2 BUTTON REMOTE PENDANT WITH QUICK DISC.

## CONFIGURATION OPTIONS

### MOTOR

- OD 3.0" 12V DC
- OD 4.5" 12/24V DC

### PUMP

- PL 0.6 - 6.0 (0.0384 - 0.3681 in<sup>3</sup>/r)

### RESERVOIR

- STEEL - 1.5 QT - 7 G
- PLASTIC - 3 QT - 14 QT

### MOUNTING

- HORIZONTAL
- VERTICAL

### MISC

- DC START SWITCH
- REMOTE PENDANT

## POWER UNIT MODEL - UM II - Circuit 111

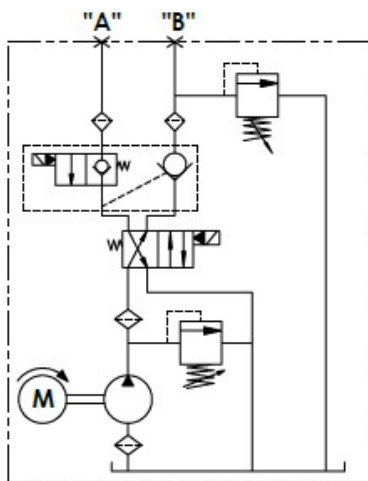

Hydraulic Circuit 111

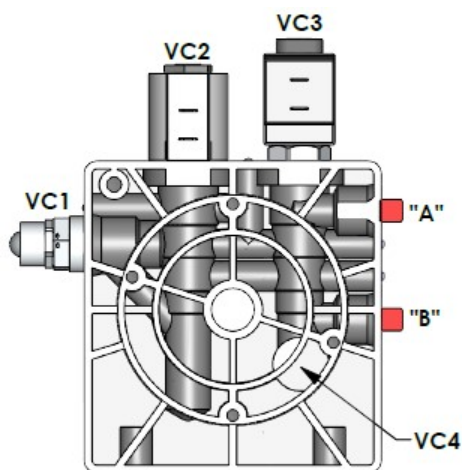

- CAVITY 1:** CARTRIDGE RELIEF VALVE
- CAVITY 2:** 4W2P DIRECTION VALVE
- CAVITY 3:** KTI PROPRIETARY LOAD HOLDING VALVE
- CAVITY 4:** 2ND RELIEF VALVE

KTI Universal Manifold II with cartridge relief valve, 4w2p valve, KTI proprietary load holding valve, and secondary relief valve.

Double acting circuit for power up, power down operation.

"A" & "B" SAE #6 (9/16-18) O-ring ports.

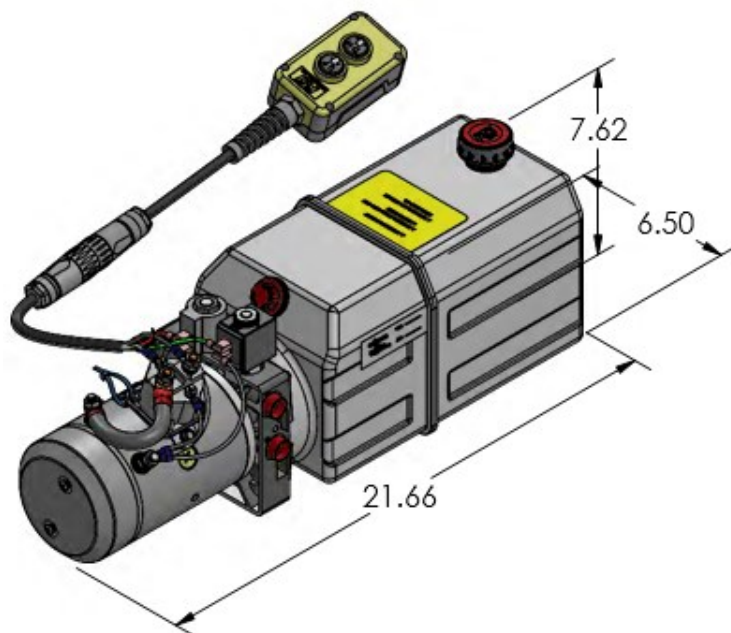

\* Dimensions are subject to change based on configuration

### AS SHOWN

- MOTOR** - 12V DC
- PUMP** - PL SERIES
- RESERVOIR** - 6 QT PLASTIC
- 2 BUTTON REMOTE PENDANT WITH QUICK DISC.

## CONFIGURATION OPTIONS

### MOTOR

- OD 3.0" 12V DC
- OD 4.5" 12/24V DC

### PUMP

- PL 0.6 - 6.0 (0.0384 - 0.3681 in<sup>3</sup>/r)

### RESERVOIR

- STEEL - 1.5 QT - 7 G
- PLASTIC - 3 QT - 14 QT

### MOUNTING

- HORIZONTAL
- VERTICAL

### MISC

- DC START SWITCH
- REMOTE PENDANT

## POWER UNIT MODEL - UM II - Circuit 114

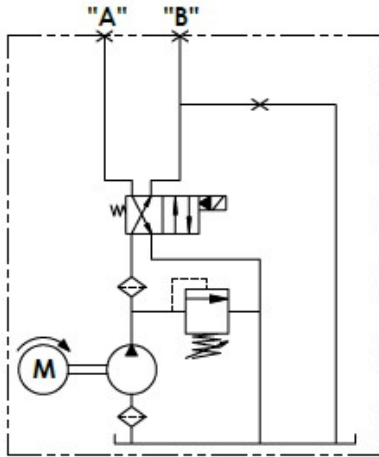

Hydraulic Circuit 114

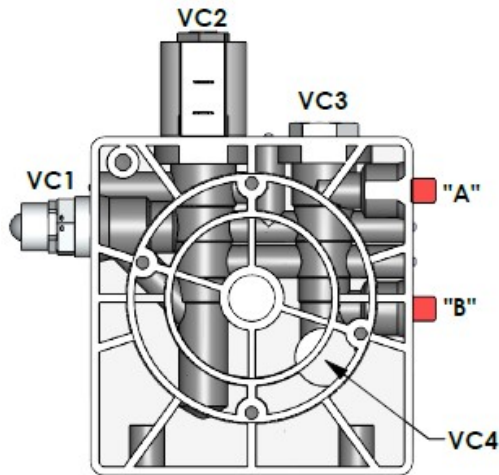

**CAVITY 1:** CARTRIDGE RELIEF VALVE

**CAVITY 2:** 4W2P DIRECTION VALVE

**CAVITY 3:** 4W CAVITY PLUG

**CAVITY 4:** PLUG

KTI Universal Manifold II with cartridge relief valve, 4w2p valve, and 4w cavity plug.

Double acting circuit for power up, power down operation.

"A" & "B" SAE #6 (9/16-18) O-ring ports.

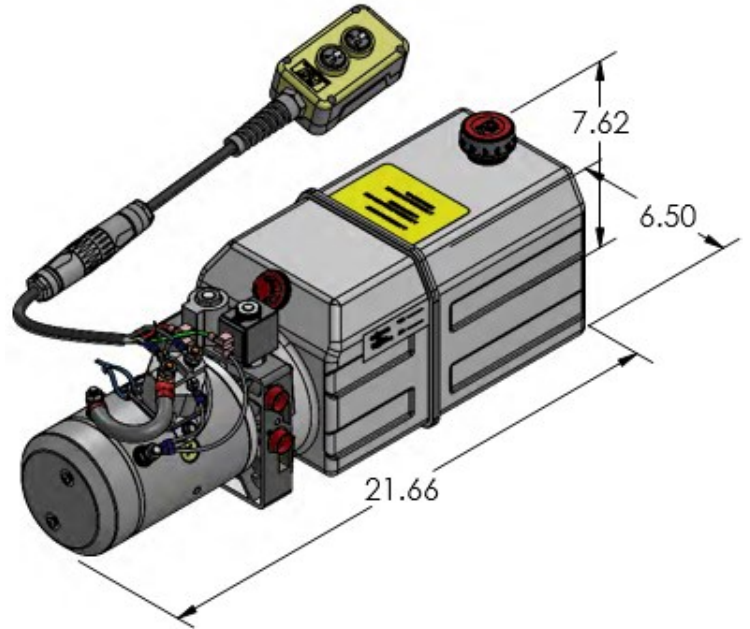

\* Dimensions are subject to change based on configuration

### AS SHOWN

**MOTOR** - 12V DC

**PUMP** - PL SERIES

**RESERVOIR** - 6 QT PLASTIC

2 BUTTON REMOTE PENDANT WITH QUICK DISCONNECT

## CONFIGURATION OPTIONS

### MOTOR

OD 3.0" 12V DC

OD 4.5" 12/24V DC

### PUMP

PL 0.6 - 6.0 (0.0384 - 0.3681 in<sup>3</sup>/r)

### RESERVOIR

STEEL - 1.5 QT - 7 G

PLASTIC - 3 QT - 14 QT

### MOUNTING

HORIZONTAL

VERTICAL

### MISC

DC START SWITCH

REMOTE PENDANT

**POWER UNIT MODEL - UM II - Circuit 114A**

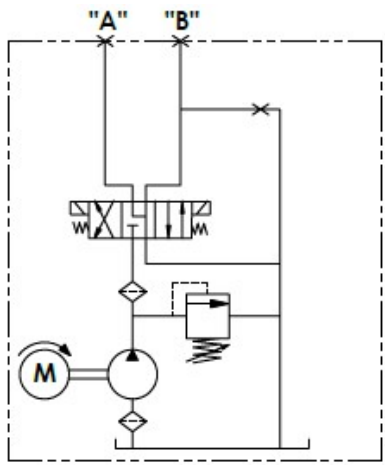

**Hydraulic Circuit 114A**

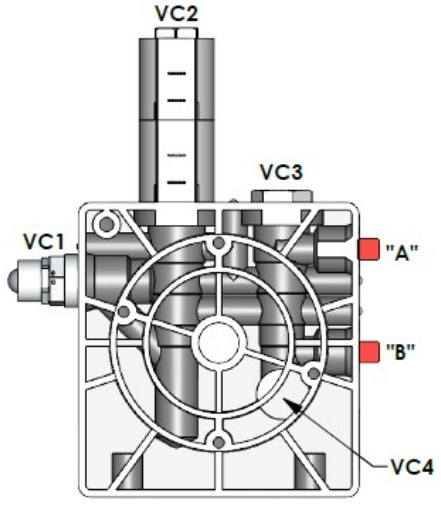

- CAVITY 1:** CARTRIDGE RELIEF VALVE
- CAVITY 2:** 4W3P MOTOR CENTER VALVE
- CAVITY 3:** 4W CAVITY PLUG
- CAVITY 4:** PLUGGED

KTI Universal Manifold II with cartridge relief valve, 4w3p valve, and 4w cavity plug.

Double acting circuit for power up, power down operation.

"A" & "B" SAE #6 (9/16-18) O-ring ports.

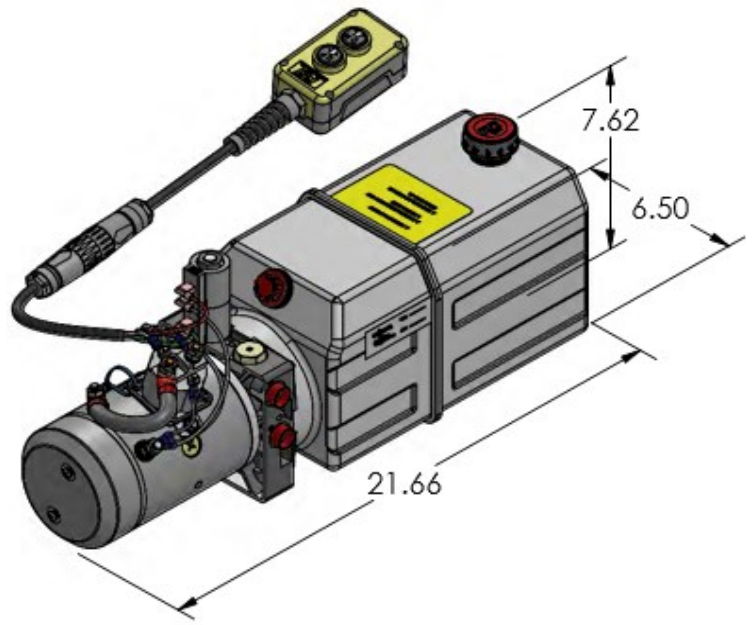

\* Dimensions are subject to change based on configuration

**AS SHOWN**

- MOTOR** - 12V DC
- PUMP** - PL SERIES
- RESERVOIR** - 6 QT PLASTIC
- 2 BUTTON REMOTE PENDANT WITH QUICK DISCONNECT

**CONFIGURATION OPTIONS**

- MOTOR**  
OD 3.0" 12V DC  
OD 4.5" 12/24V DC
- PUMP**  
PL 0.6 - 6.0 (0.0384 - 0.3681 in<sup>3</sup>/r)
- RESERVOIR**  
STEEL - 1.5 QT - 7 G  
PLASTIC - 3 QT - 14 QT

- MOUNTING**  
HORIZONTAL  
VERTICAL
- MISC**  
DC START SWITCH  
REMOTE PENDANT

## POWER UNIT MODEL - UM II - Circuit 114B

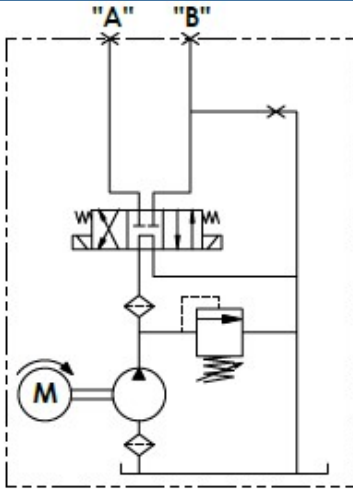

Hydraulic Circuit 114B

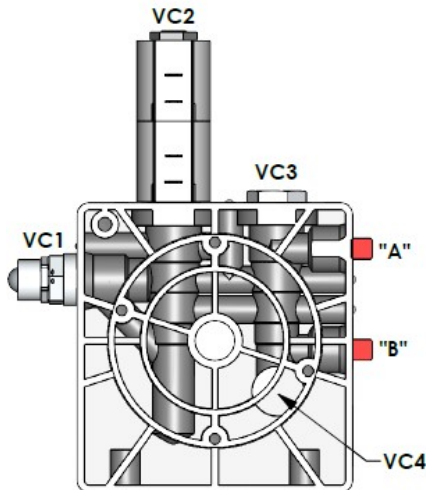

- CAVITY 1:** CARTRIDGE RELIEF VALVE
- CAVITY 2:** 4W3P TANDEM CENTER VALVE
- CAVITY 3:** 4W CAVITY PLUG
- CAVITY 4:** PLUGGED

KTI Universal Manifold II with cartridge relief valve, 4w3p valve, and 4w cavity plug.

Double acting circuit for power up, power down operation.

"A" & "B" SAE #6 (9/16-18) O-ring ports.

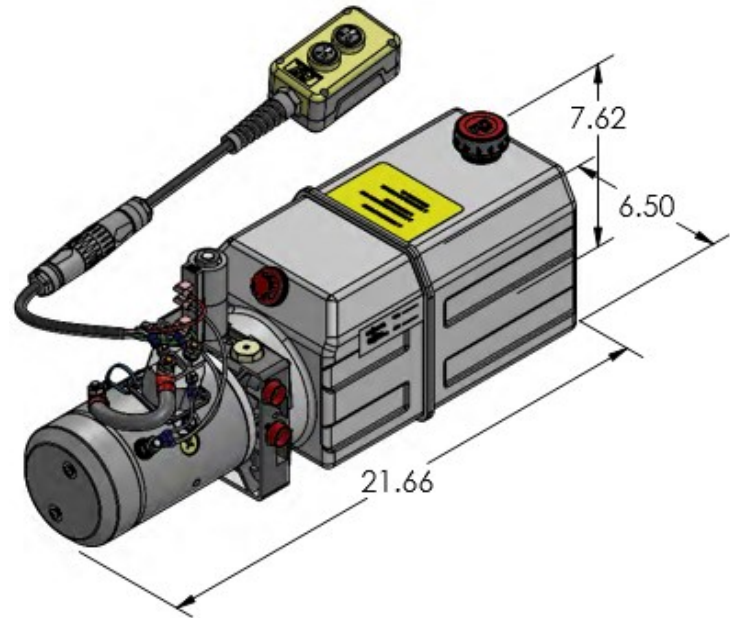

\* Dimensions are subject to change based on configuration

### AS SHOWN

- MOTOR** - 12V DC
- PUMP** - PL SERIES
- RESERVOIR** - 6 QT PLASTIC
- 2 BUTTON REMOTE PENDANT WITH QUICK DISC.

## CONFIGURATION OPTIONS

### MOTOR

- OD 3.0" 12V DC
- OD 4.5" 12/24V DC

### PUMP

- PL 0.6 - 6.0 (0.0384 - 0.3681 in<sup>3</sup>/r)

### RESERVOIR

- STEEL - 1.5 QT - 7 G
- PLASTIC - 3 QT - 14 QT

### MOUNTING

- HORIZONTAL
- VERTICAL

### MISC

- DC START SWITCH
- REMOTE PENDANT



## POWER UNIT MODEL - UM II - Circuit 114C

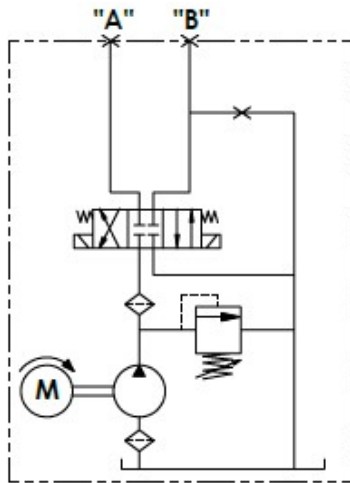

Hydraulic Circuit 114C

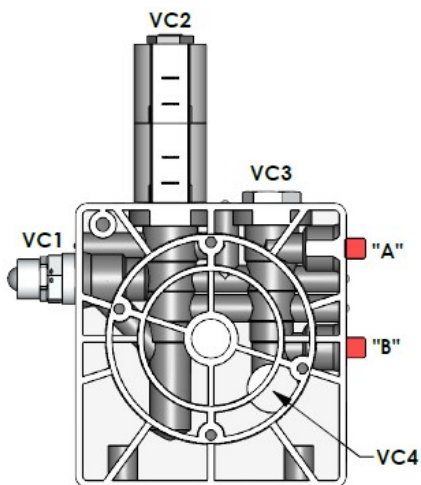

- CAVITY 1:** CARTRIDGE RELIEF VALVE
- CAVITY 2:** 4W3P CLOSE CENTER VALVE
- CAVITY 3:** 4W CAVITY PLUG
- CAVITY 4:** PLUGGED

KTI Universal Manifold II with cartridge relief valve, 4w3p valve, and 4w cavity plug.

Double acting circuit for power up, power down operation.

"A" & "B" SAE #6 (9/16-18) O-ring ports.

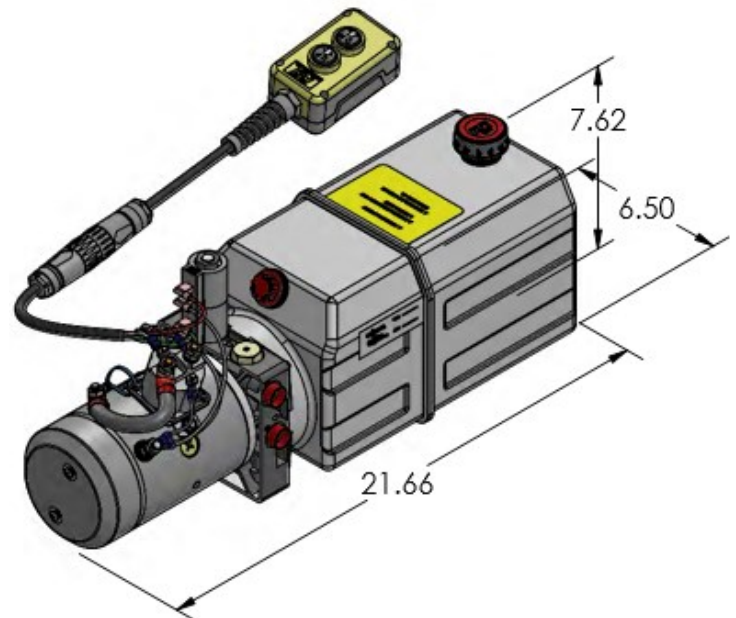

\* Dimensions are subject to change based on configuration

### AS SHOWN

- MOTOR** - 12V DC
- PUMP** - PL SERIES
- RESERVOIR** - 6 QT PLASTIC
- 2 BUTTON REMOTE PENDANT WITH QUICK DISC.

## CONFIGURATION OPTIONS

### MOTOR

- OD 3.0" 12V DC
- OD 4.5" 12/24V DC

### PUMP

- PL 0.6 - 6.0 (0.0384 - 0.3681 in<sup>3</sup>/r)

### RESERVOIR

- STEEL - 1.5 QT - 7 G
- PLASTIC - 3 QT - 14 QT

### MOUNTING

- HORIZONTAL
- VERTICAL

### MISC

- DC START SWITCH
- REMOTE PENDANT

## POWER UNIT MODEL - UM II - Circuit 114D

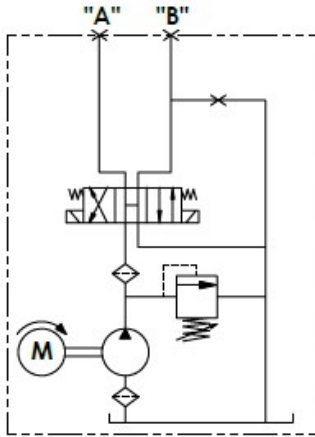

Hydraulic Circuit 114D

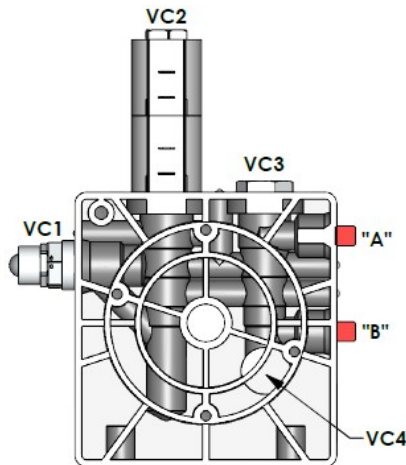

- CAVITY 1:** CARTRIDGE RELIEF VALVE
- CAVITY 2:** 4W3P OPEN CENTER VALVE
- CAVITY 3:** 4W CAVITY PLUG
- CAVITY 4:** PLUGGED

KTI Universal Manifold II with cartridge relief valve, 4w3p valve, and 4w cavity plug.

Double acting circuit for power up, power down operation.

"A" & "B" SAE #6 (9/16-18) O-ring ports.

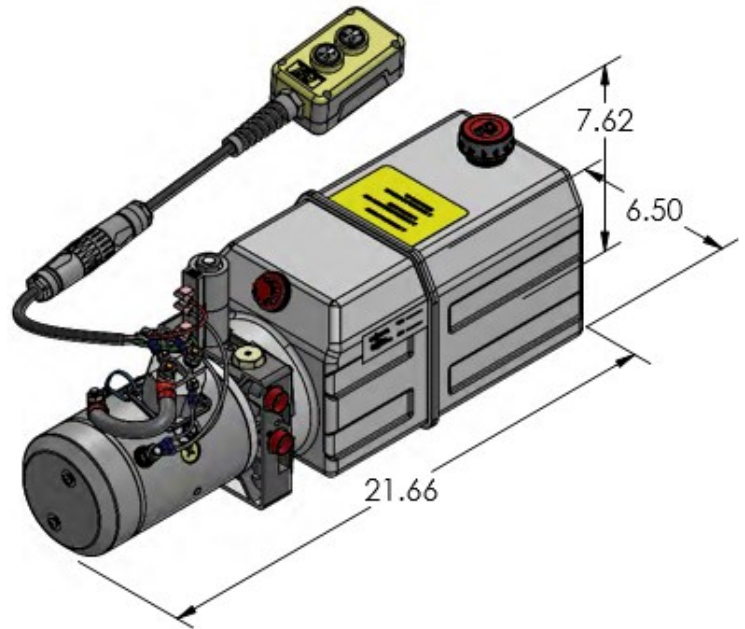

\* Dimensions are subject to change based on configuration

### AS SHOWN

- MOTOR** - 12V DC
- PUMP** - PL SERIES
- RESERVOIR** - 6 QT PLASTIC
- 2 BUTTON REMOTE PENDANT WITH QUICK DISC.

## CONFIGURATION OPTIONS

### MOTOR

- OD 3.0" 12V DC
- OD 4.5" 12/24V DC

### PUMP

- PL 0.6 - 6.0 (0.0384 - 0.3681 in<sup>3</sup>/r)

### RESERVOIR

- STEEL - 1.5 QT - 7 G
- PLASTIC - 3 QT - 14 QT

### MOUNTING

- HORIZONTAL
- VERTICAL

### MISC

- DC START SWITCH
- REMOTE PENDANT

## POWER UNIT MODEL - 115 MANIFOLD

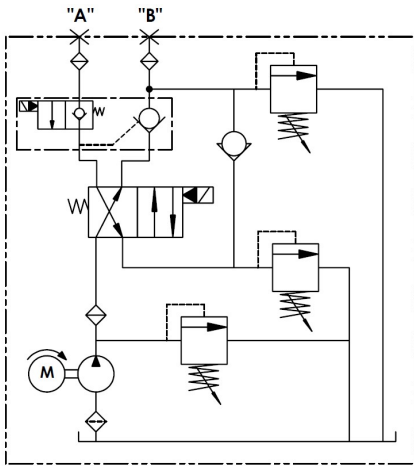

**Hydraulic Circuit 115**

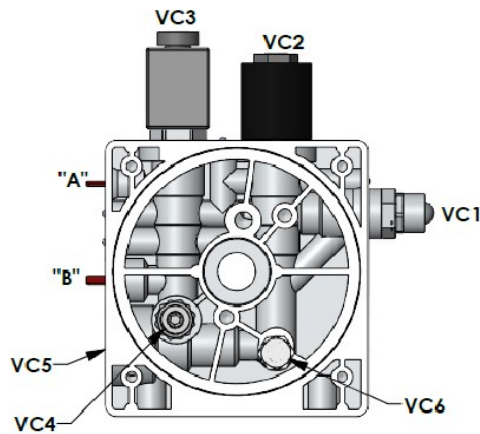

- CAVITY 1:** CARTRIDGE RELIEF VALVE
- CAVITY 2:** 4W2P DIRECTION VALVE
- CAVITY 3:** KTI PROPRIETARY LOAD HOLDING VALVE
- CAVITY 4:** 2ND RELIEF VALVE
- CAVITY 5:** CARTRIDGE CHECK VALVE
- CAVITY 6:** BACK PRESSURE VALVE

KTI 115 manifold with cartridge relief valve, 4w2p direction valve, KTI proprietary load holding valve, secondary relief valve, and back pressure valve.

Double acting circuit for power up, power down, and gravity down operation.

"A" & "B" SAE #6 (9/16-18) O-ring ports.

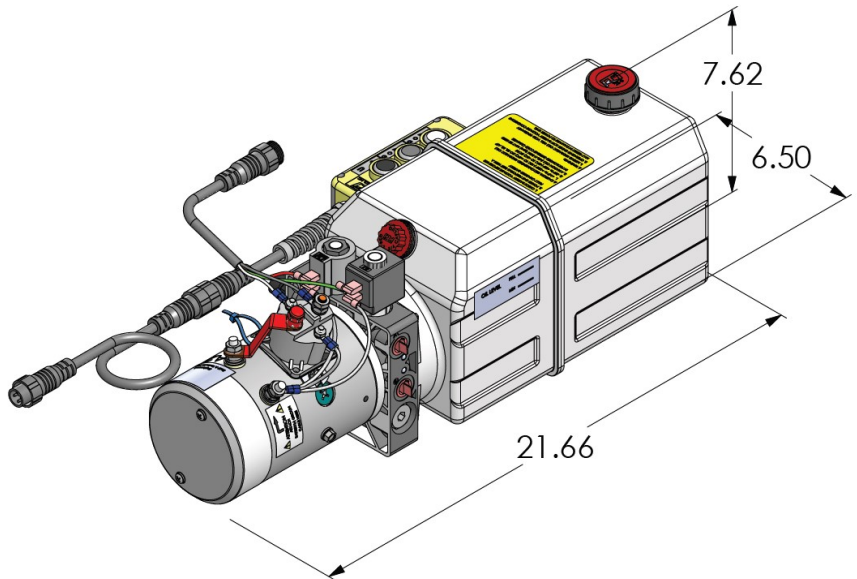

\* Dimensions are subject to change based on configuration

### AS SHOWN

- MOTOR** - 12V DC
- PUMP** - PL SERIES
- RESERVOIR** - 6 QT PLASTIC
- 3 BUTTON REMOTE PENDANT WITH QUICK DISCONNECT

## CONFIGURATION OPTIONS

### MOTOR

- OD 3.0" 12V DC
- OD 4.5" 12/24V DC

### PUMP

- PL 0.6 - 6.0 (0.0384 - 0.3681 in<sup>3</sup>/r)

### RESERVOIR

- STEEL - 1.5 QT - 7 G
- PLASTIC - 3 QT - 14 QT

### MOUNTING

- HORIZONTAL
- VERTICAL

### MISC

- DC START SWITCH
- REMOTE PENDANT

## POWER UNIT MODEL - UM III - Circuit 208

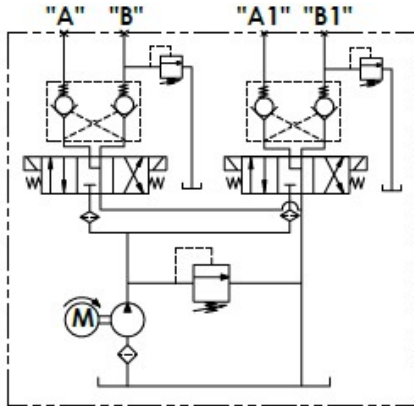

Hydraulic Circuit 208

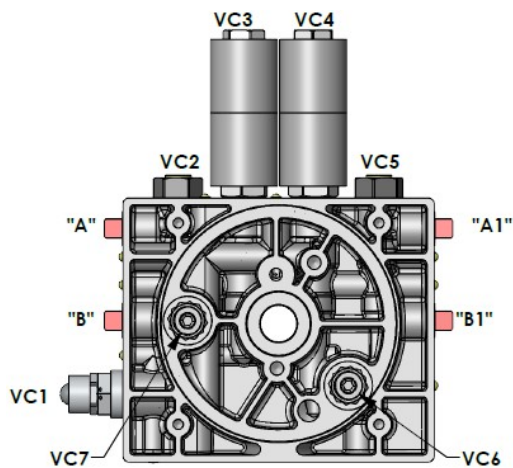

- CAVITY 1: CARTRIDGE RELIEF VALVE
- CAVITY 2: DUAL PILOT OPERATED CHECK VALVE
- CAVITY 3: 4W3P MOTOR CENTER VALVE
- CAVITY 4: 4W3P MOTOR CENTER VALVE
- CAVITY 5: DUAL PILOT OPERATED CHECK VALVE
- CAVITY 6: 2ND RELIEF VALVE
- CAVITY 7: 2ND RELIEF VALVE

KTI Universal Manifold III with cartridge relief valve, dual pilot operated check valve, 4w3p motor center cartridge solenoid valve, secondary relief valve.

Dual double acting circuit for dual independent double acting operation

"A" & "B" "A1" & "B1" SAE #6 (9/16-18) O-ring ports.

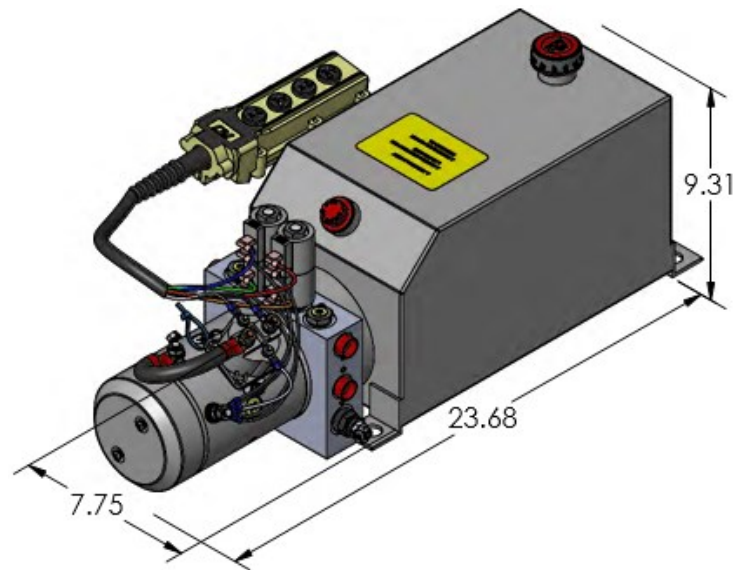

\* Dimensions are subject to change based on configuration

### AS SHOWN

- MOTOR - 12V DC
- PUMP - PL SERIES
- RESERVOIR - 12 QT STEEL
- 4 BUTTON REMOTE PENDANT

## CONFIGURATION OPTIONS

### MOTOR

- OD 3.0" 12V DC
- OD 4.5" 12/24V DC

### PUMP

- PL 0.6 - 6.0 (0.0384 - 0.3681 in<sup>3</sup>/r)

### RESERVOIR

- STEEL - 1.5 QT - 7 G
- PLASTIC - 3 QT - 14 QT

### MOUNTING

- HORIZONTAL
- VERTICAL

### MISC

- DC START SWITCH
- REMOTE PENDANT

## POWER UNIT MODEL - UM III - Circuit 211

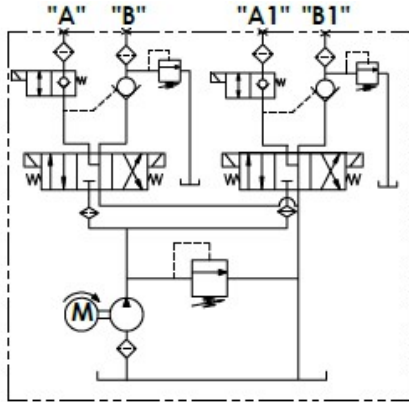

**Hydraulic Circuit 211**

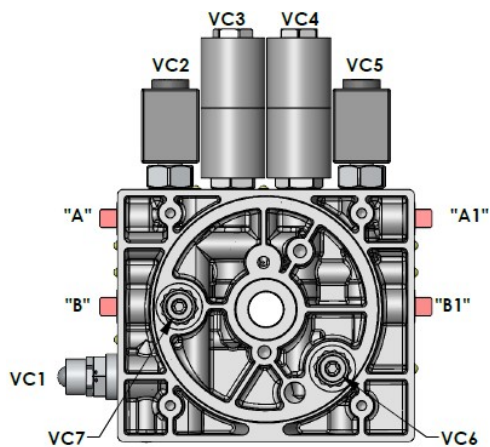

**CAVITY 1:** CARTRIDGE RELIEF VALVE

**CAVITY 2:** KTI PROPRIETARY LOAD HOLDING VALVE

**CAVITY 3:** 4W3P MOTOR CENTER, CARTRIDGE SOLENOID VALVE

**CAVITY 4:** 4W3P MOTOR CENTER, CARTRIDGE SOLENOID VALVE

**CAVITY 5:** KTI PROPRIETARY LOAD HOLDING VALVE

**CAVITY 6:** 2ND RELIEF VALVE

**CAVITY 7:** 2ND RELIEF VALVE

KTI Universal Manifold III with cartridge relief valve, KTI proprietary load holding valve, 4w3p motor center cartridge solenoid valve, and secondary relief valve.

Dual double acting circuit for dual independent double acting operation.

"A" & "B" "A1" & "B1" SAE #6 (9/16-18) O-ring ports.

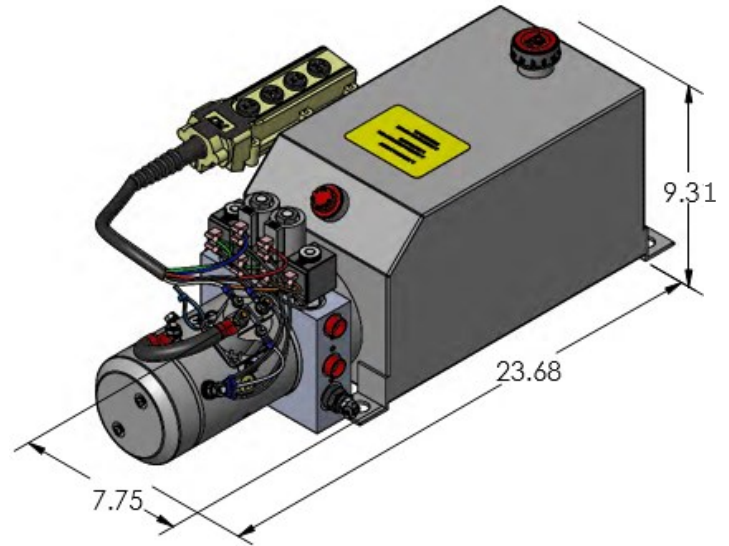

\* Dimensions are subject to change based on configuration

### AS SHOWN

**MOTOR** - 12V DC

**PUMP** - PL SERIES

**RESERVOIR** - 12 QT STEEL

4 BUTTON REMOTE PENDANT

## CONFIGURATION OPTIONS

### MOTOR

OD 3.0" 12V DC

OD 4.5" 12/24V DC

### PUMP

PL 0.6 - 6.0 (0.0384 - 0.3681 in<sup>3</sup>/r)

### RESERVOIR

STEEL - 1.5 QT - 7 G

PLASTIC - 3 QT - 14 QT

### MOUNTING

HORIZONTAL

VERTICAL

### MISC

DC START SWITCH

REMOTE PENDANT



## POWER UNIT MODEL - UM III - Circuit 215

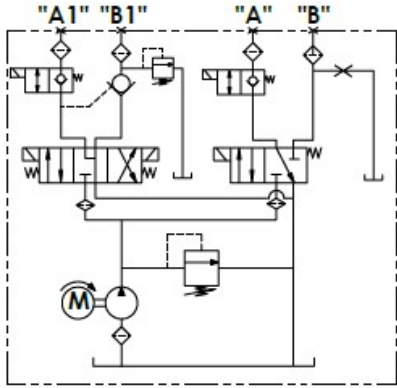

**Hydraulic Circuit 215**

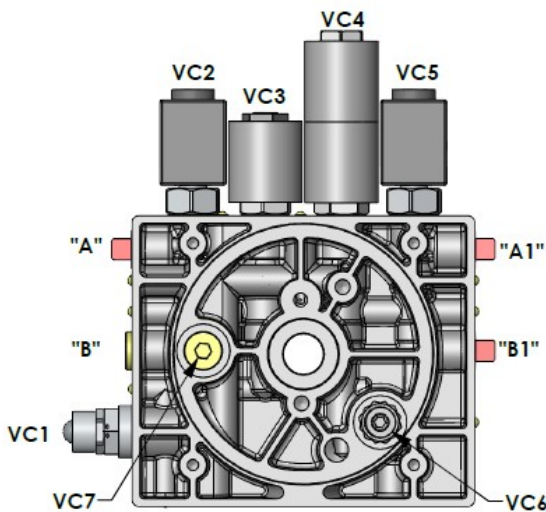

- CAVITY 1:** CARTRIDGE RELIEF VALVE
- CAVITY 2:** NC 2WAY VALVE
- CAVITY 3:** 4W2P SPOOL TYPE CARTRIDGE SOLENOID VALVE
- CAVITY 4:** 4W3P MOTOR CENTER, CARTRIDGE SOLENOID VALVE
- CAVITY 5:** KTI PROPRIETARY LOAD HOLDING VALVE
- CAVITY 6:** 2ND RELIEF VALVE
- CAVITY 7:** PLUG

KTI Universal Manifold III with cartridge relief valve, 4w2p spool type cartridge solenoid valve, 4w3p motor center cartridge solenoid valve, KTI proprietary load holding valve, and secondary relief valve.

Independent operation of a double action function & single acting function power unit.

"A" & "B" "A1" & "B1" SAE #6 (9/16-18) O-ring ports.

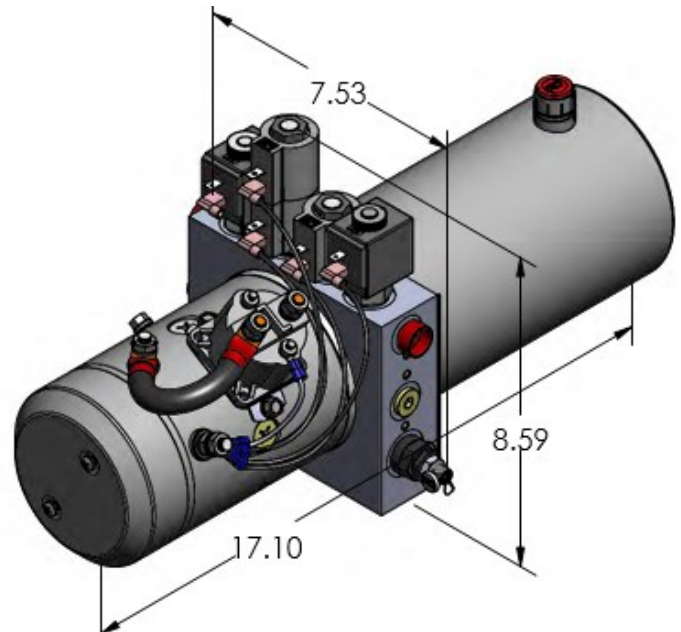

\* Dimensions are subject to change based on configuration

### AS SHOWN

- MOTOR** - 12V DC
- PUMP** - PL SERIES
- RESERVOIR** - 2 QT STEEL

## CONFIGURATION OPTIONS

### MOTOR

- OD 3.0" 12V DC
- OD 4.5" 12/24V DC

### PUMP

- PL 0.6 - 6.0 (0.0384 - 0.3681 in<sup>3</sup>/r)

### RESERVOIR

- STEEL - 1.5 QT - 20 QT
- PLASTIC - 3 QT - 14 QT

### MOUNTING

- HORIZONTAL
- VERTICAL

### MISC

- DC START SWITCH
- REMOTE PENDANT

## POWER UNIT MODEL - UM III - Circuit 216

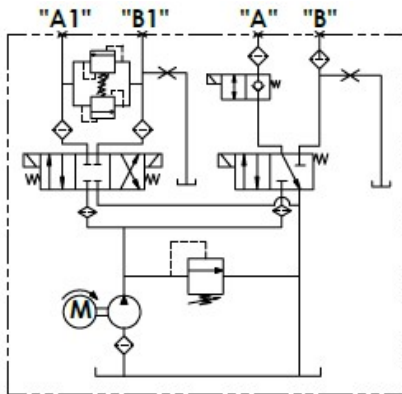

Hydraulic Circuit 216

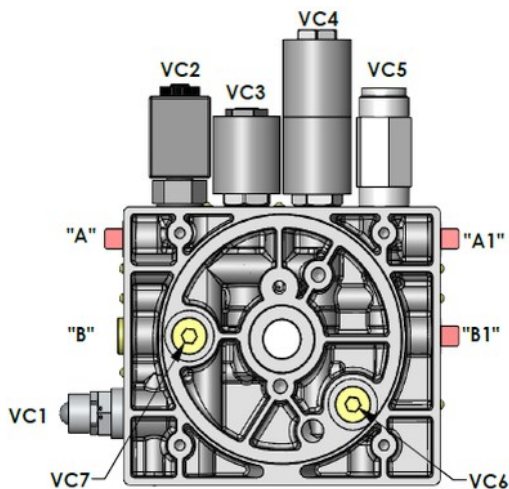

- CAVITY 1: CARTRIDGE RELIEF VALVE
- CAVITY 2: NC 2WAY VALVE
- CAVITY 3: 4W2P SPOOL TYPE CARTRIDGE SOLENOID VALVE
- CAVITY 4: 4W3P CLOSE CENTER SPOOL TYPE CARTRIDGE SOLENOID VALVE
- CAVITY 5: ADJUSTABLE DIRECTIONAL, BI-DIRECTIONAL RELIEF VALVE
- CAVITY 6: PLUG
- CAVITY 7: PLUG

KTI Universal Manifold III with cartridge relief valve, 4w2p spool type valve, 4w3p close center spool valve, adjustable directional, and bi-directional relief valve.

Snow plow with power angling, cross over relief with lift, check, lower & float function.

"A" & "B" "A1" & "B1" SAE #6 (9/16-18) O-ring ports.

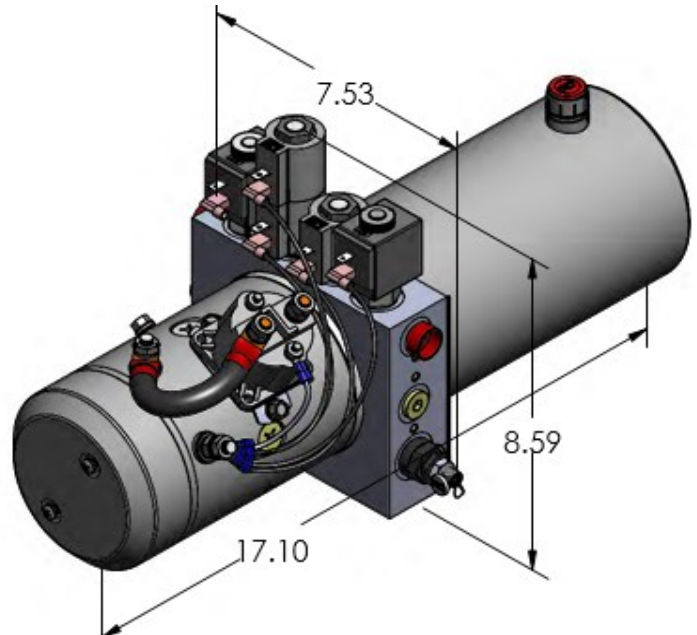

\* Dimensions are subject to change based on configuration

### AS SHOWN

- MOTOR - 12V DC
- PUMP - PL SERIES
- RESERVOIR - 2 QT STEEL

## CONFIGURATION OPTIONS

### MOTOR

- OD 3.0" 12V DC
- OD 4.5" 12/24V DC

### PUMP

- PL 0.6 - 6.0 (0.0384 - 0.3681 in<sup>3</sup>/r)

### RESERVOIR

- STEEL - 1.5 QT - 20 QT
- PLASTIC - 3 QT - 14 QT

### MOUNTING

- HORIZONTAL
- VERTICAL

### MISC

- DC START SWITCH

## POWER UNIT MODEL - UM III - Circuit 217

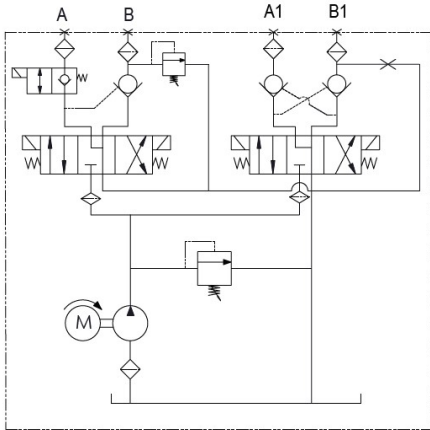

### Hydraulic Circuit 217

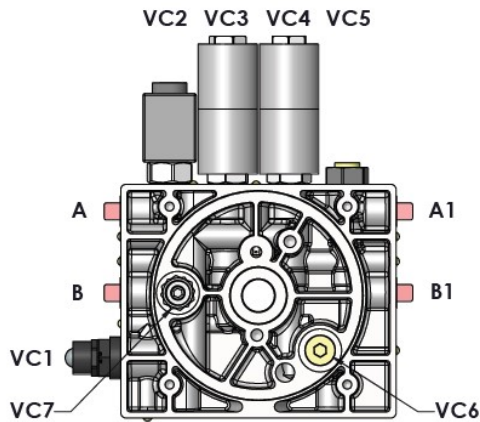

- CAVITY 1:** CARTRIDGE RELIEF VALVE
- CAVITY 2:** KTI PROPRIETARY LOAD HOLDING VALVE
- CAVITY 3:** 4W3P MOTOR CENTER, CARTRIDGE SOLENOID VALVE
- CAVITY 4:** 4W3P MOTOR CENTER, CARTRIDGE SOLENOID VALVE
- CAVITY 5:** DUAL PILOT OPERATED CHECK VALVE
- CAVITY 6:** PLUG
- CAVITY 7:** 2ND RELIEF VALVE

KTi Universal Manifold III, Hydraulic Circuit 217. Dual double acting circuit for dual independent double acting operation. Motor, KTi Manifold (with cartridge relief valve, KTi proprietary load holding valve, dual pilot operated check valve, 4w3p motor center cartridge solenoid valve, secondary relief valve), Pump, Tank.

"A" & "B" "A1" & "B1" SAE #6 (9/16-18) O-ring ports.

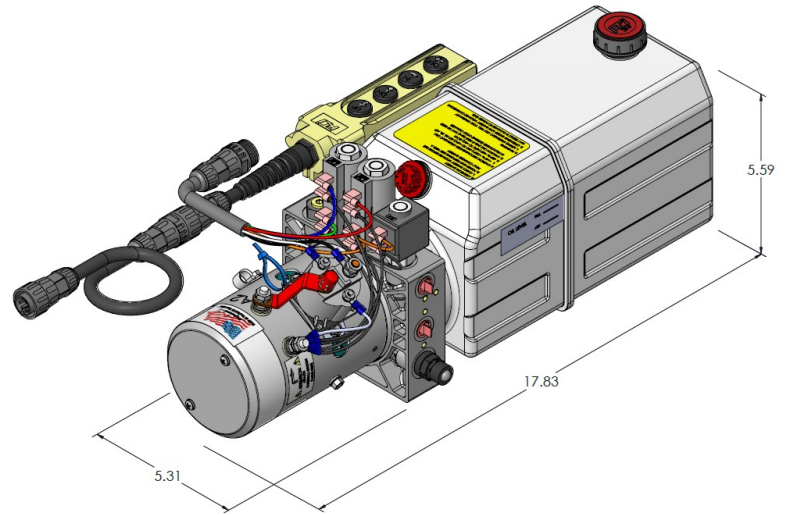

\* Dimensions are subject to change based on configuration

### AS SHOWN

- MOTOR** - 12V DC
- PUMP** - PL SERIES
- RESERVOIR** - 6 QT STEEL
- 4 BUTTON REMOTE PENDANT WITH QUICK DISCONNECT

## CONFIGURATION OPTIONS

### MOTOR

- OD 3.0" 12V DC
- OD 4.5" 12/24V DC

### PUMP

- PL 0.6 - 6.0 (0.0384 - 0.3681 in<sup>3</sup>/r)

### RESERVOIR

- STEEL - 1.5 QT - 20 QT
- PLASTIC - 3 QT - 14 QT

### MOUNTING

- HORIZONTAL
- VERTICAL

### MISC

- DC START SWITCH
- REMOTE PENDANT

## SUBMERGED HYDRAULIC POWER UNIT

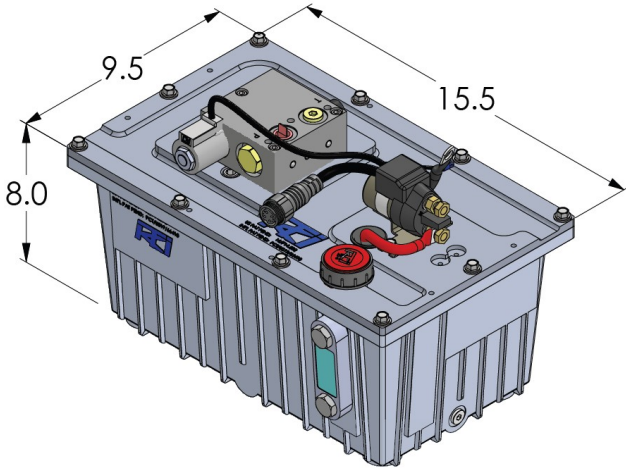

The KT Hydraulic Submerged motor power unit incorporates an IP68 electric motor mounted in the hydraulic oil reservoir. This unique design offers many benefits over a traditional hydraulic power unit. Some of these benefits are the motor is protected from outside elements and the hydraulic oil will act as a coolant for the motor resulting in longer duty cycles. The compact design allows the unit to be mounted in places a traditional hydraulic power unit would not package. The custom configurable add on manifolds make it possible for the base unit to be configured with multiple hydraulic circuit options.

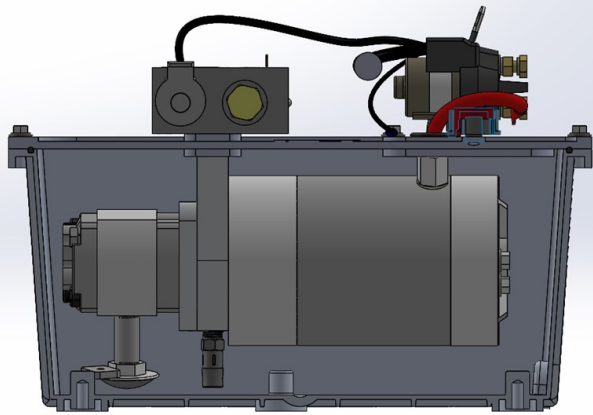

<b>Motor</b>	12V DC 1.8kW
<b>Pressure</b>	500 - 3800 PSI ( 35 - 262 BAR )
<b>Pump</b>	0.63 - 3.20 cm <sup>3</sup> / rev (0.0384 - 0.1953 in <sup>3</sup> / rev)
<b>Reservoir</b>	5 Quarts Usable Volume
<b>Control</b>	Heavy Duty DC Starter Solenoid Push-button remote pendant Wireless remote
<b>Dimensions</b>	L 15.5" x W 9.5" x H 8.0" (394 mm x 241 mm x 203 mm)
<b>Add On</b>	Oil Gauge
<b>Max Operating Temperature</b>	Approximately 212° F (100° C)
<b>Fluid Compatibility</b>	ISO 24 - 32 & ATF

US PAT PEND: 16/714.592, INTL PAT PEND: PCT/US19/66410

## CONFIGURATION OPTIONS

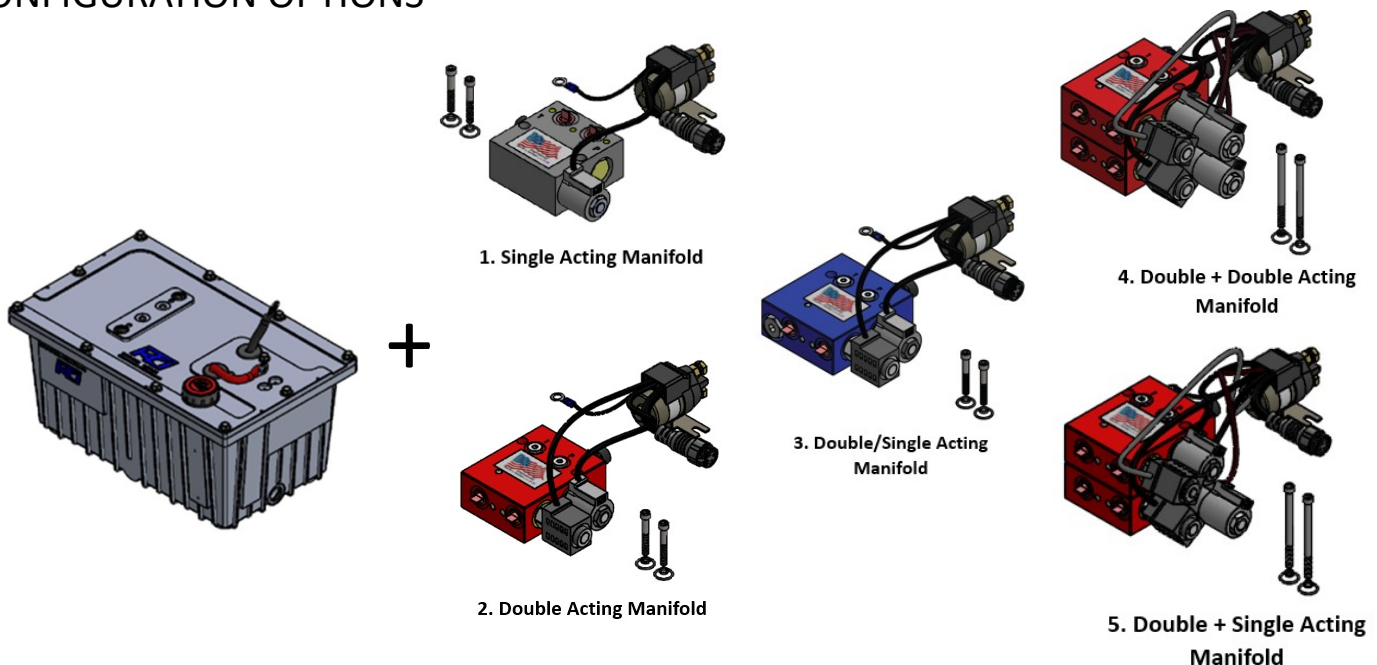



**CIRCUITS**

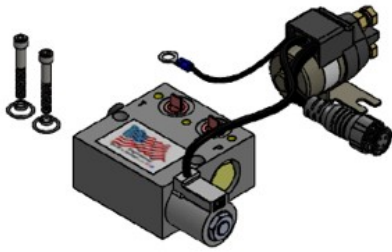

**1. Single Acting Manifold**

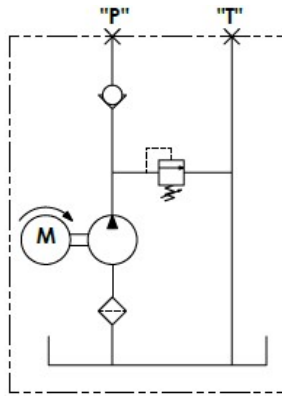

**102**

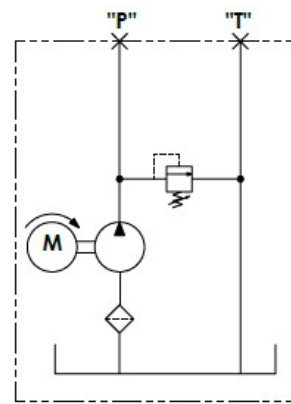

**102A**

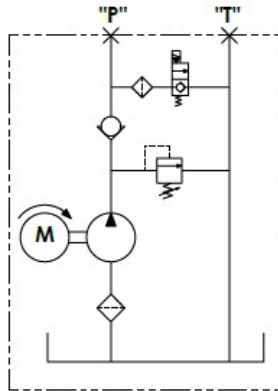

**103**

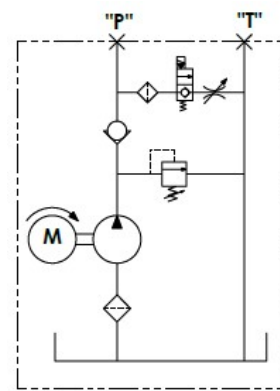

**104A**

*Including Circuits 102B, 103A, 104B, 105*

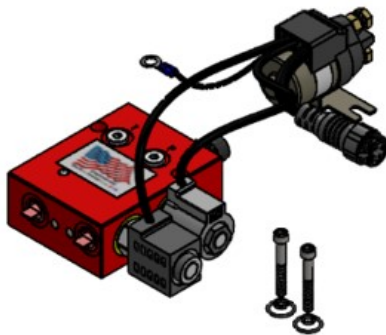

**2. Double Acting Manifold**

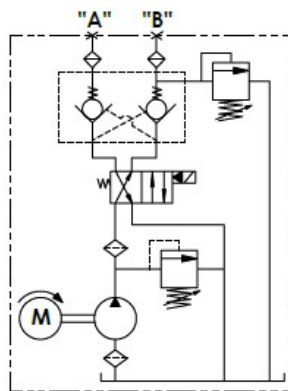

**108**

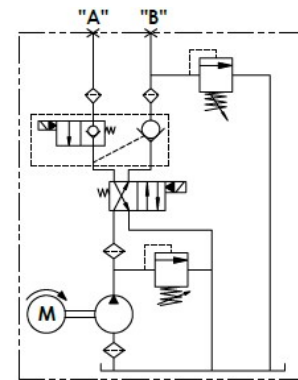

**111**

*Including Circuits 109, 110, 114, 114A, 114B, 114C, 114D*



**SUBMERGED HYDRAULIC POWER UNIT**

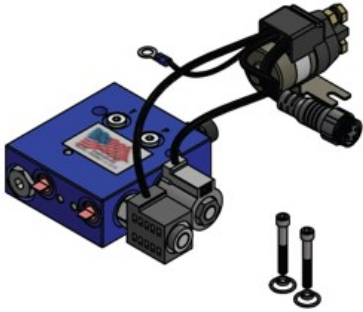

**3. Double/Single Acting Manifold**

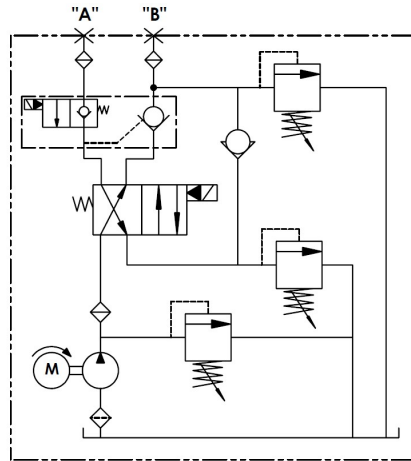

115

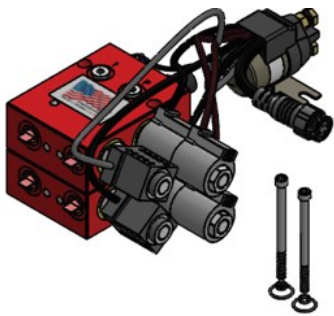

**4. Double + Double Acting Manifold**

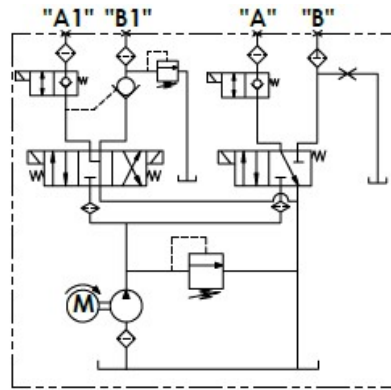

215

*Including Circuit 216*

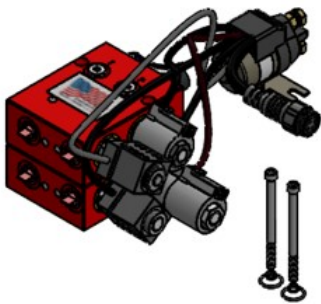

**5. Double + Single Acting Manifold**

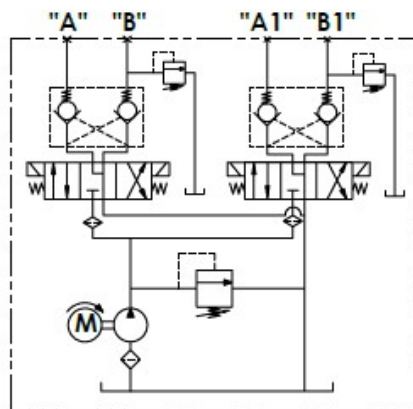

208

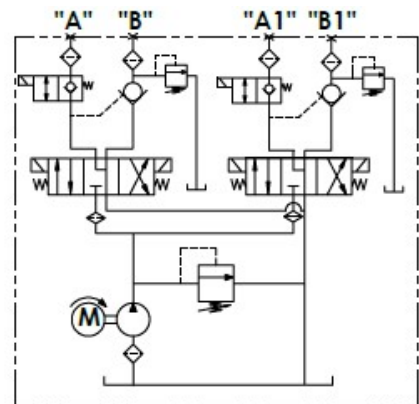

211

*Including Circuit 217*

# 3.0" OD PERMANENT MAGNET MOTOR



## OVERVIEW

3.0" O.D. Permanent Magnet Motor with spline shaft. This motor is excellent for intermittent duty and low pressure application.

		12V		24V	
<b>TORQUE</b>	IN-LB	NO LOAD	17	NO LOAD	80
<b>VOLTAGE</b>	V	12.1	11.9	24	23.7
<b>CURRENT</b>	AMP	15.3	269	15	85
<b>SPEED</b>	RPM	6400	2232	6500	4000
<b>POWER</b>	W	N/A	2113	1097	2324

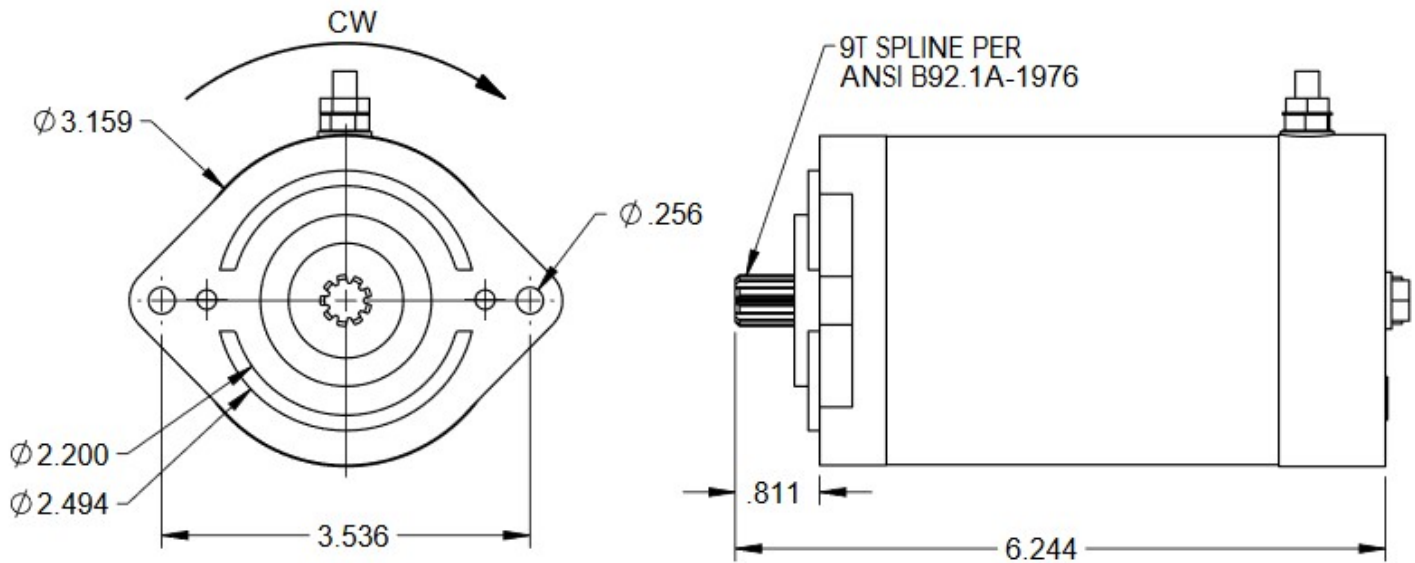

\* Dimension lengths are subject to change based on final configuration

ORDER LETTER	DESCRIPTION
B	12V DC, 3.0" OD, 1 OR 2 TERMINAL

\* 24V available upon request. Thermal switch, IP65, insulated ground, non-eared, non-insulated ground motors also available. Please contact KTI for performance curve information

# 4.5" OD, FOUR FIELD SERIES WOUND MOTOR



## OVERVIEW

4.5" OD Heavy Duty 12V & 24V DC Electric Motor

		12V		24V	
TORQUE	IN-LB	20	80	20	80
VOLTAGE	V	12.1	11.9	24	23.7
CURRENT	AMP	128	269	60	143
SPEED	RPM	4291	2232	4635	2458
POWER	W	1015	2113	1097	2324

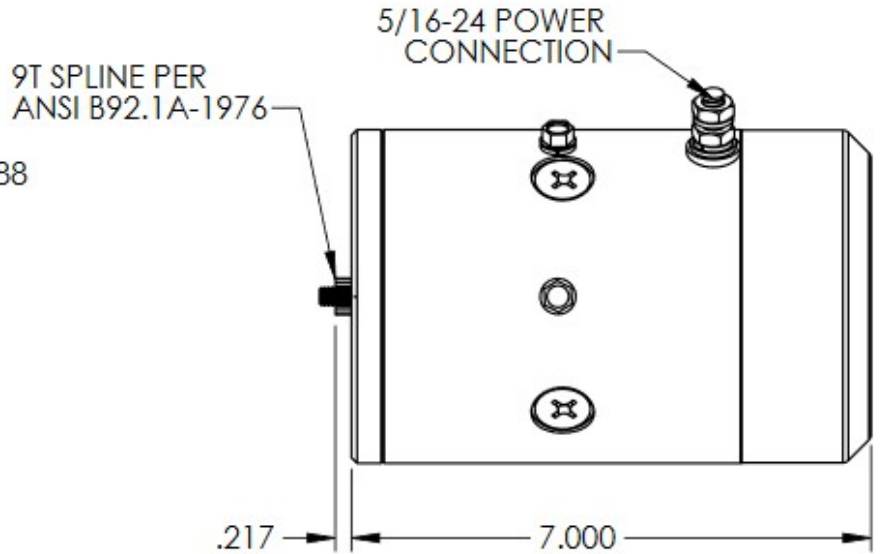
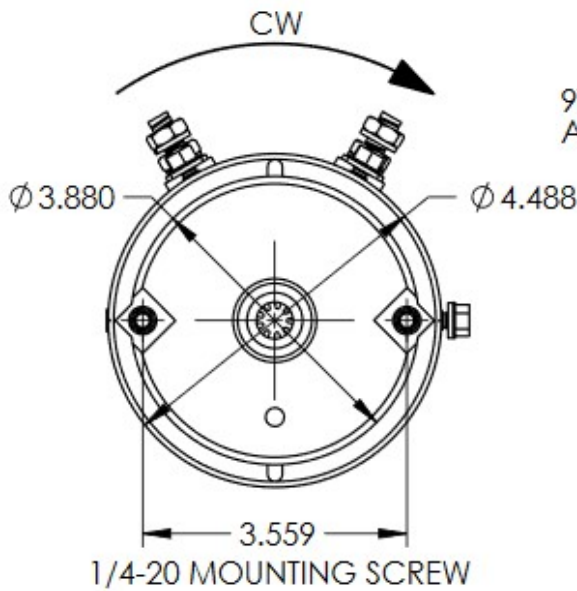

\* Dimension lengths are subject to change based on final configuration

ORDER LETTER	DESCRIPTION
A	12V DC, 4.5" OD 2 TERMINAL, 1.6 kW
C	24V DC, 4.5" OD 2 TERMINAL

\* The following 12V DC, 4.5" motors are available upon request - 1.8 kW, 2.0 kW, 2.2 kW

\* Thermal switch, IP65 motors also available upon request. Please contact KTI for performance curve information.

# 5.0" OD MAGNET MOTOR

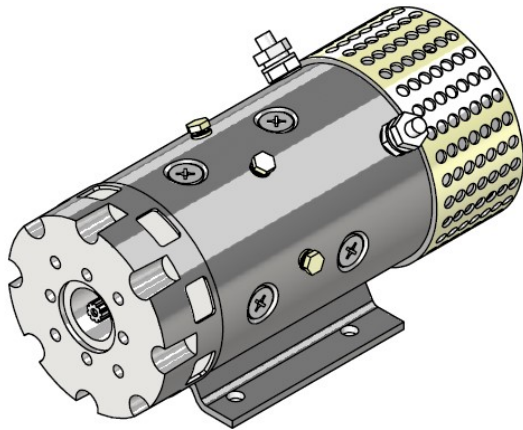

## OVERVIEW

5.0" O.D. Footed & Dual Rated, Heavy Duty, Open End Fan Cooled. 12V & 24V DC Electric Motor. This is for continuous duty, high pressure application.

		12V		24V	
<b>TORQUE</b>	IN-LB	106	203	100	200
<b>VOLTAGE</b>	V	11.6	11.2	23.6	23.2
<b>CURRENT</b>	AMP	211	323	183	322
<b>SPEED</b>	RPM	1478	1076	3026	2300
<b>POWER</b>	W	1857	2591	3581	5443

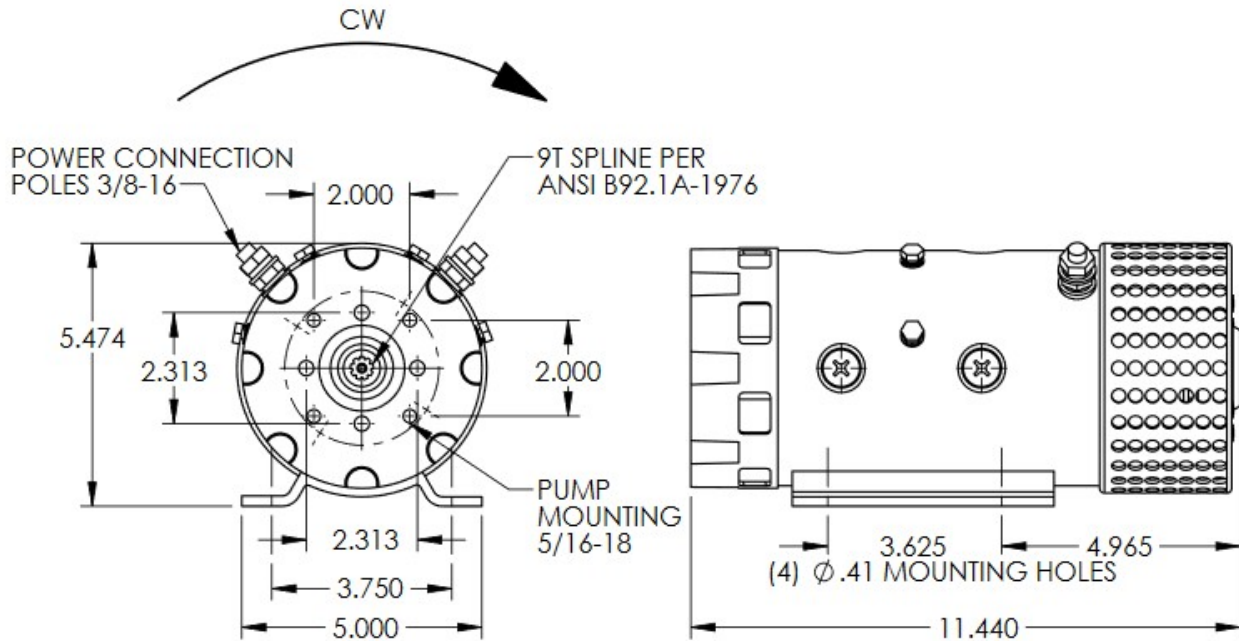

\* Dimension lengths are subject to change based on final configuration

ORDER LETTER	DESCRIPTION
R	12V/24V DC, 5.0" OD, 1 TERMINAL

\* Please inquire about pricing / availability / performance.

\* Available in non-footed version

# KTI 12/24V DC AUXILIARY PUMP & 4.5" MOTOR ASSEMBLY

		<p><b>AS SHOWN</b></p> <p><b>MOTOR:</b> 12V/24V DC 4.5" DIAMETER MOTOR</p> <p><b>STARTER:</b> CONTINUOUS DUTY START SOLENOID</p> <p><b>PUMP:</b> STN PRESSURE LOADED GEAR PUMP</p>
--	--	--

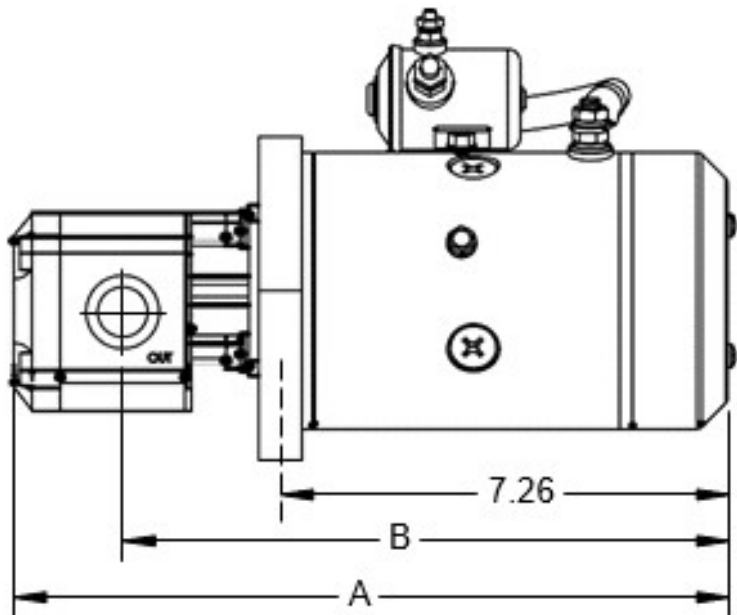
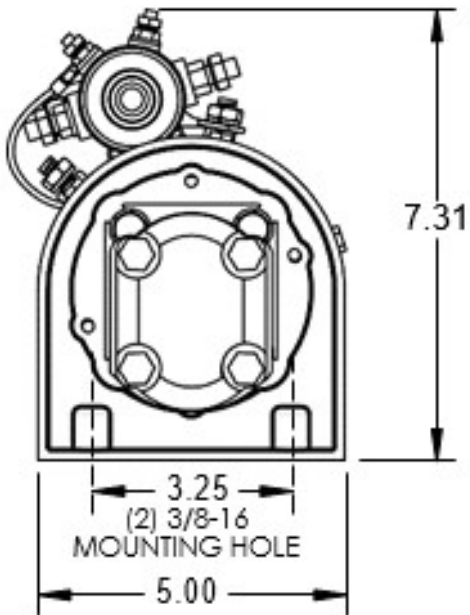

12V DC Model Number	24V DC Model Number	PUMP DISPL. in <sup>3</sup> /r (mL/r)	DIM A (IN)	DIM B (IN)	INLET	OUTLET
DC 4002	DC 4012	0.083 (1.36)	15.33	9.75	SAE #10 7/8 - 14	SAE #8 3/4-16
DC 4003	DC 4013	0.125 (2.05)	15.41	9.79		
DC 4004	DC 4014	0.167 (2.74)	15.49	9.84		
DC 4005	DC 4015	0.209 (3.24)	15.57	9.87		
DC 4006	DC 4016	0.250 (4.10)	15.64	9.97		



# KTI 12/24V DC AUXILIARY PUMP & MOTOR ASSEMBLY

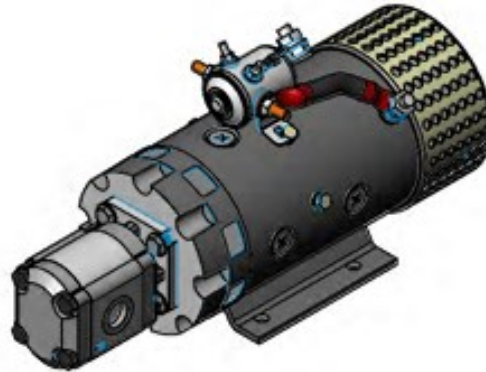
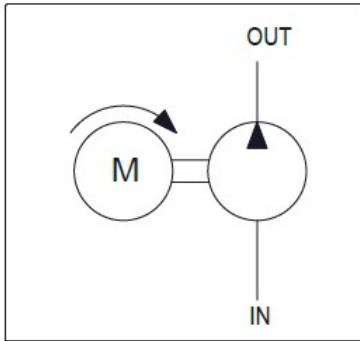

AS SHOWN

**MOTOR:** 12V/24V DC 5.0" DIAMETER MOTOR

**STARTER:** CONTINUOUS DUTY START SOLENOID

**PUMP:** STN PRESSURE LOADED GEAR PUMP

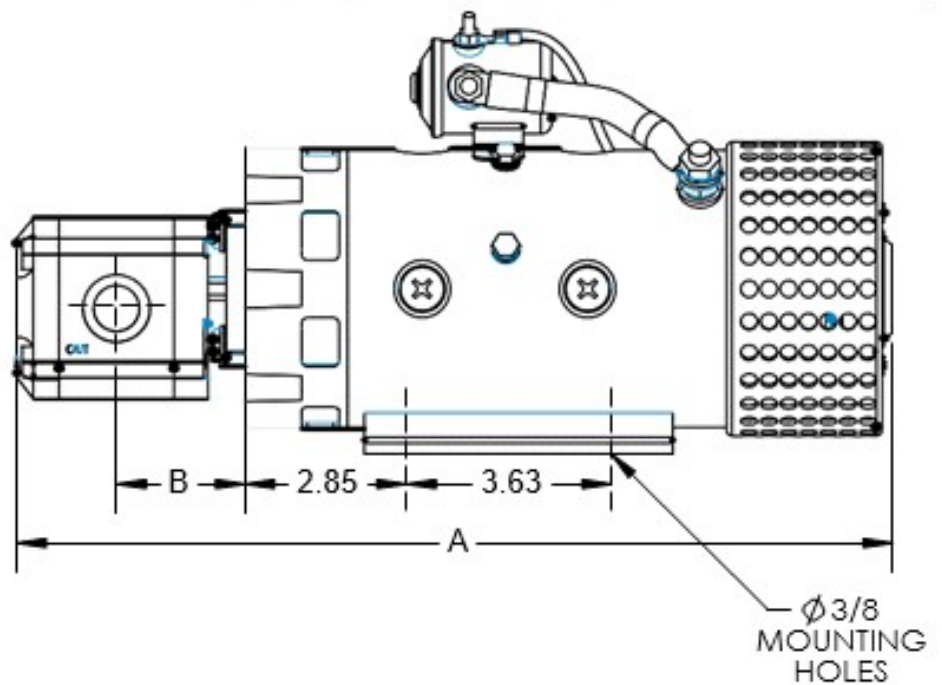
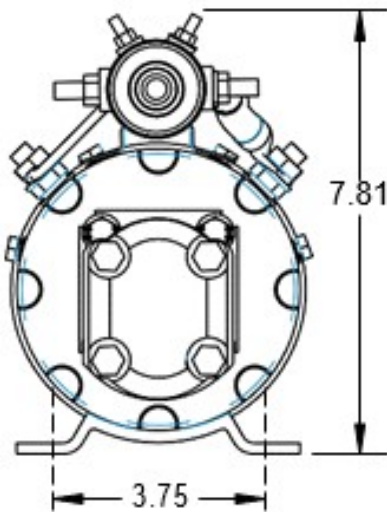

12V DC Model Number	24V DC Model Number	PUMP DISPL. in <sup>3</sup> /r (mL/r)	DIM A (IN)	DIM B (IN)	INLET	OUTLET
DC 5002	DC 5012	0.083 (1.36)	15.33	2.31	SAE #10 7/8 - 14	SAE #8 3/4-16
DC 5003	DC 5013	0.125 (2.05)	15.41	2.35		
DC 5004	DC 5014	0.167 (2.74)	15.49	2.40		
DC 5005	DC 5015	0.209 (3.24)	15.57	2.43		
DC 5006	DC 5016	0.250 (4.10)	15.64	2.47		

## AC MOTORS

# SINGLE PHASE - 4920 SERIES

### OVERVIEW

KTI Hydraulics uses US made motors for our AC power units. The available power range is from 0.5 HP to 5 HP; 1725 to 3450 rpm; 1 PH, 115 / 208-230V AC; 56 frame, C-face, 5/8" diameter keyed shaft, CW rotation; Open Drip Proof (ODP) and Totally Enclosed Fan Cooled (TEFC).

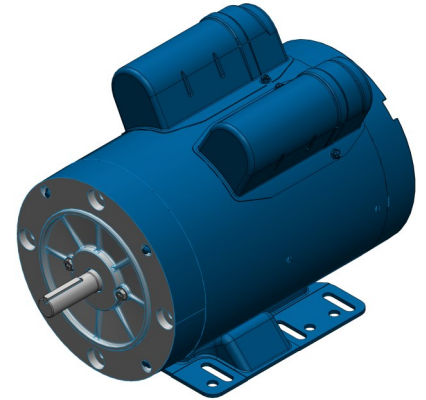

Part Number	HP	RPM	VOLT	Hz	Enclosure
4920-25	0.5	1725	115 / 208-230	60	TEFC
4920-64	0.5	1725	110 / 208-230	60	TEFC
4920-68	0.75	1725	115 / 208-230	60	ODP
4920-69	0.75	1725	115 / 208-230	60	ODP
4920-44	1.0	1750	115 / 208-230	60	TEFC
4920-72	1.0	1725	115 / 230	60	ODP
4920-28	1.5	1725	115 / 208-230	60	TEFC
4920-58	1.5	1725	115 / 208-230	60	TEFC
4920-75	2.0	1750	208-230	60	TEFC
4920-54	1.0	3450	115 / 208-230	60	TEFC
4920-80	1.0	3450	115 / 208-230	60	TEFC
4920-67	1.5	3450	115 / 208-230	60	TEFC
4920-46	2.0	3450	208-230	60	TEFC
4920-51	3.0	3450	208-230	60	TEFC
4920-87	5.0	3450	230	60	TEFC

# SINGLE PHASE - 5920 SERIES

### OVERVIEW

5920 series AC motors allow direct mounting to manifolds and minimize its overall length by eliminating the need for an adaptor. The available power range is from 0.5 HP to 2.0 HP; 1725 to 3450 rpm; 1 PH, 115 / 208-230V AC; 56 HZ frame, 9-Tooth Spline shaft, CW rotation; Totally Enclosed Non-Ventilated (TENV), and Totally Enclosed Fan Cooled (TEFC)

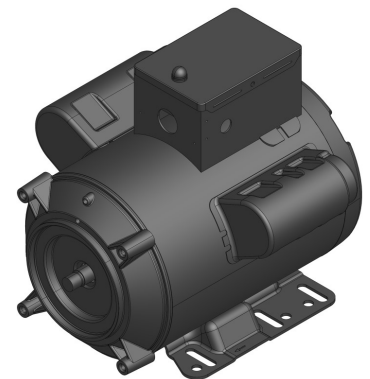

Part Number	HP	RPM	VOLT	Hz	Enclosure
5920-02	2.0	3450 / 2850	208-230 / 220	60 / 50	TEFC
5920-03	1.5	3450 / 2850	115 / 208-230	60 / 50	TEFC
5920-04	1.0	2450 / 2850	115 / 208-230	60 / 50	TENV
5920-05	1.0	2450 / 2850	115 / 230	60	TENV
5920-06	2.0	3450 / 2850	208-230 / 220	60 / 50	TEFC
5920-09	0.5	1725 / 1425	115 / 208-230	60 / 50	TEFC
5920-10	0.5	1725 / 1425	115 / 208-230	60 / 50	TENV

## AC MOTORS

# THREE PHASE - 4920 SERIES

## OVERVIEW

KTI Hydraulics uses US made motors for our AC power units. The available power range is from 0.5 HP to 3 HP; 1750 to 3450 rpm; 3 PH, 208-230 / 460 / 575V AC; 56 frame, C-face, 5/8" diameter keyed shaft, CW rotation; Totally Enclosed Non-Ventilated (TENV), and Totally Enclosed Fan Cooled (TEFC).

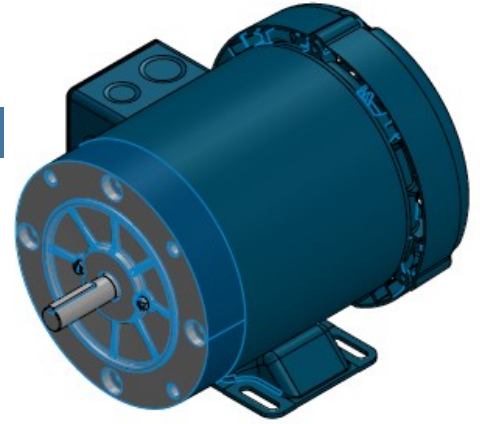

Part Number	HP	RPM	VOLT	Hz	Enclosure
4920-41	0.5	1750	208-230 / 460	60	TEFC
4920-65	0.5	1800	575	60	TEFC
4920-76	1.0	1800	208-230 / 460	60	TEFC
4920-77	1.0	1800	575	60	TEFC
4920-59	1.5	1725	208-230 / 460	60	TEFC
4920-36	2.0	1750	208-230 / 460	60	TEFC
4920-71	2.0	1740	208-230 / 460	60	TEFC
4920-57	1.0	3450	208-230 / 460	60	TEFC
4920-81	1.0	3450	208-230 / 460	60	TEFC
4920-73	1.0	3450	575	60	TEFC
4920-34	2.0	3450	208-230 / 460	60	TEFC
4920-70	2.0	3450	208-230 / 460	60	TENV
4920-35	3.0	3450	208-230 / 460	60	TEFC

# THREE PHASE - 5920 SERIES

## OVERVIEW

5920 series AC motors allow direct mounting to manifolds and minimize its overall length by eliminating the need for an adaptor. The available power range is from 1.0 HP to 3.0 HP; 3450 rpm; 220V, 460V AC; 56 HZ frame, 9-Tooth Spline shaft, CW rotation; Totally Enclosed Non-Ventilated (TENV), and Totally Enclosed Fan Cooled (TEFC)

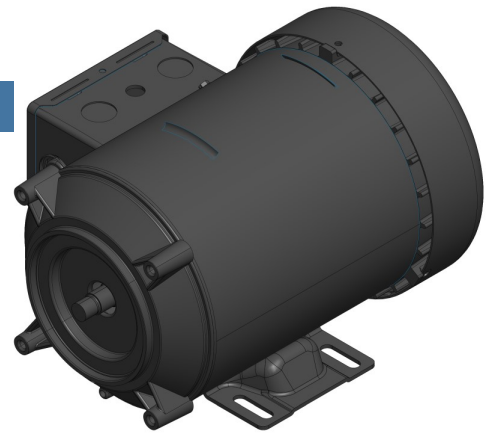

Part Number	HP	RPM	VOLT	Hz	Enclosure
5920-07	2.0	3450 / 2850	220 / 460	60 / 50	TEFC
5920-08	3.0	3450 / 2850	220 / 460	60 / 50	TEFC
5920-11	2.0	3450 / 2850	220 / 460	60 / 50	TEFC
5920-12	3.0	3450 / 2850	220 / 460	60 / 50	TEFC
5920-13	1.0	3450 / 2850	220 / 460	60 / 50	TENV

\* Additional options are available upon request. Please contact KTI for more details.

\* For dimensions, please contact KTI for details.

# PL SERIES - PRESSURE LOADED GEAR PUMP

## OVERVIEW

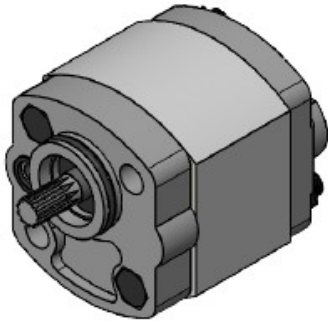

The KTI PL series pressure loaded gear pump consists of a pair of gears supported by two aluminum bearing blocks, center housing, front and rear cover. The PL series pump features high mechanical and volumetric efficiency, low noise level as well as high reliability.

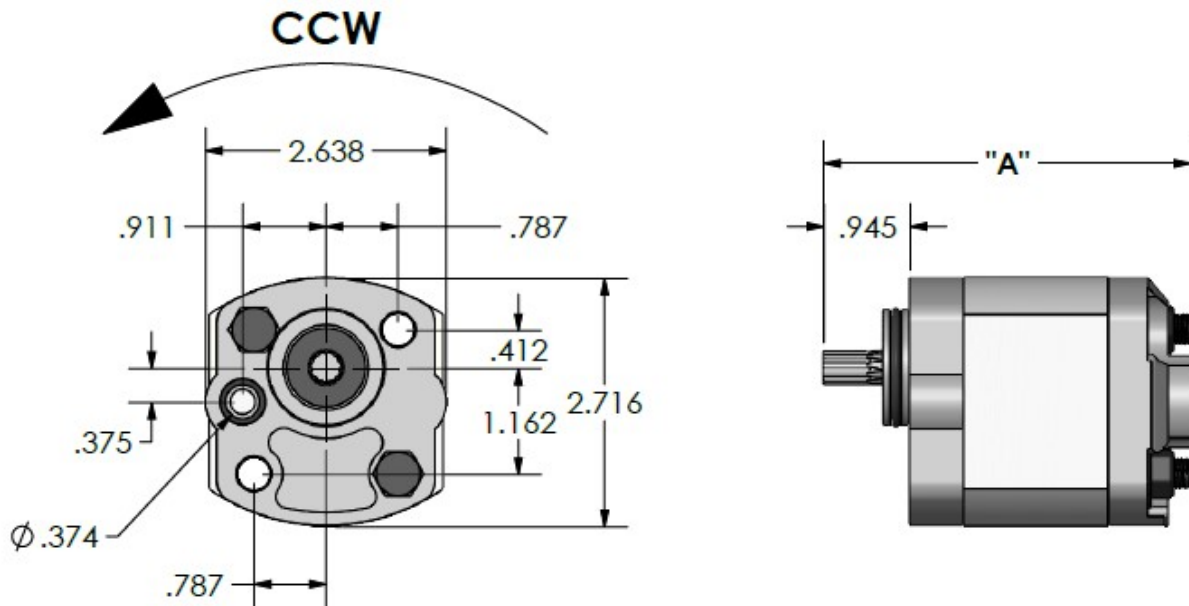

\*Dimensions are subject to change based on final configuration

ORDER LETTER	PART NO.	DISPLACEMENT (in <sup>3</sup> /r)	PRESSURE (Bar/PSI)		LENGTH A (in.)
			RATE	MAX	
M	PL-0.63-11T	0.0383	200/2900	280/4061	3.80
L	PL-0.80-11T	0.0488	200/2900	280/4061	3.84
B	PL-1.20-11T	0.0732	200/2900	280/4061	3.90
O	PL-1.50-11T	0.0915	200/2900	280/4061	3.93
C	PL-1.60-11T	0.0976	200/2900	280/4061	3.96
D	PL-2.10-11T	0.1281	200/2900	280/4061	4.04
N	PL-2.50-11T	0.1525	200/2900	280/4061	4.10
E	PL-2.70-11T	0.1648	200/2900	280/4061	4.14
G	PL-3.20-11T	0.1952	200/2900	280/4061	4.22
H	PL-4.20-11T-ES	0.2563	180/2610	260/3770	4.37
I	PL-5.10-11T-ES	0.3113	138/2000	227/3300	4.49
J	PL-6.00-11T-ES	0.3661	138/2000	227/3300	4.63

**PERFORMANCE:**

1. DISPLACEMENT: 0.0383-0.3661 in<sup>3</sup>/r.
2. WORKING PRESSURE: 2000 PSI, MAX PRESSURE: 4000 PSI
3. ROTATION DIRECTION: COUNTERCLOCKWISE

\* All pumps above are 11-tooth male spline shaft (SAE 11-T)

\* Tang shafts available upon request

\* Other displacements available upon request

# STN SERIES - PRESSURE LOADED GEAR PUMP

## OVERVIEW

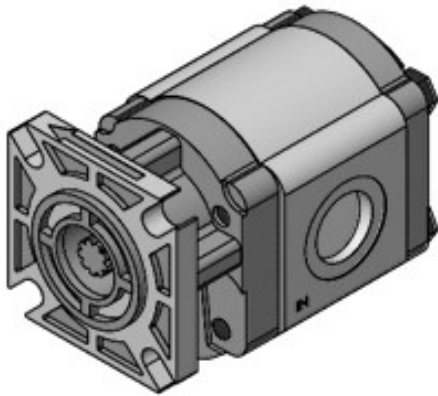

The KTI STN series pressure loaded gear pump consists of a pair of gears supported by two aluminum bearing blocks, center housing, front and rear cover with American Standard 4F17 mounting. The STN pump features simple structure, high mechanical, volumetric efficiency, low noise level as well as high reliability. It is widely used in the hydraulic systems of trucks, lifts, transport machinery, mine machinery, and agriculture machinery.

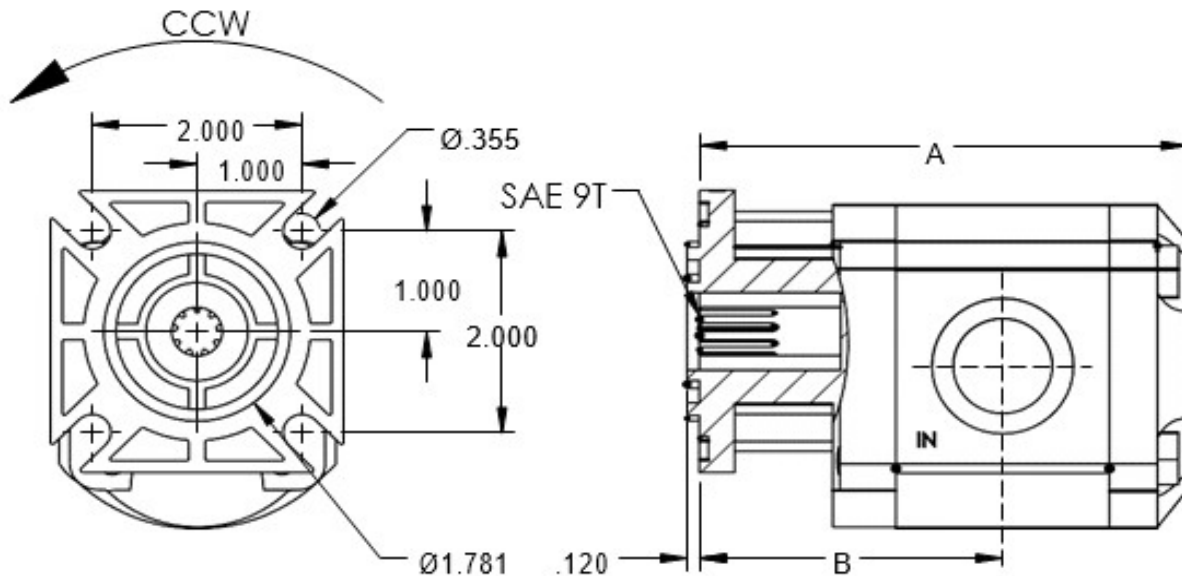

\*Dimensions are subject to change based on final configuration

PART NO.	DISPLACEMENT in <sup>3</sup> /r (mL/r)	PRESSURE (Bar/PSI)		A (in)	B (in)	INLET	OUTLET
		RATE	MAX				
STN 2	0.083 (1.36)	200 / 2900	280/4061	3.89	2.31	SAE #10 7/8-14	SAE #8 3/4-16
STN 3	0.125 (2.05)	200 / 2900	280 / 4061	3.97	2.35		
STN 4	0.167 (2.74)	200 / 2900	280 / 4061	4.05	2.40		
STN 5	0.209 (3.42)	200 / 2900	280 / 4061	4.13	2.43		
STN 6	0.250 (4.10)	200 / 2900	280 / 4061	4.20	2.47		
STN 8	0.376 (6.16)	200 / 2900	280 / 4061	4.33	2.58		

**PERFORMANCE:**

1. DISPLACEMENT: 0.083-0.376 in<sup>3</sup>/r.
2. WORKING PRESSURE: 2900 PSI, MAX PRESSURE: 4061 PSI
3. ROTATING SPEED: 2000-4000 rpm
4. ROTATION DIRECTION: COUNTERCLOCKWISE

\* All pumps above are 9-tooth male spline shafts (SAE 9T)



# CBS SERIES - PRESSURE LOADED GEAR PUMP

## OVERVIEW

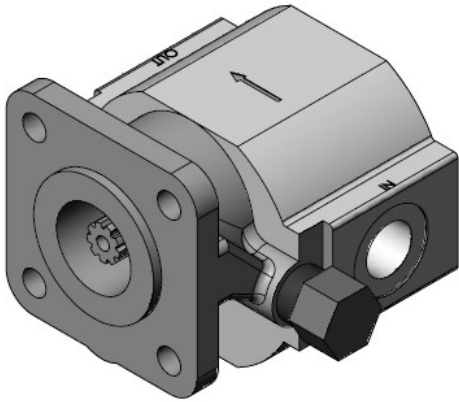

The KTI CBS series pressure loaded pump consists of a pair of gears supported by two aluminum bearing blocks, center housing, front and rear cover with American Standard 4F17 mounting. The CBS pump can accommodate a check valve, relief valve, or both integrated into the body of the pump which allows for a compact design. This pump features simple structure, high mechanical, volumetric efficiency, low noise level as well as high reliability. It is widely used in the hydraulic systems of trucks, lifts, transport machinery, mining machinery, and agriculture machinery.

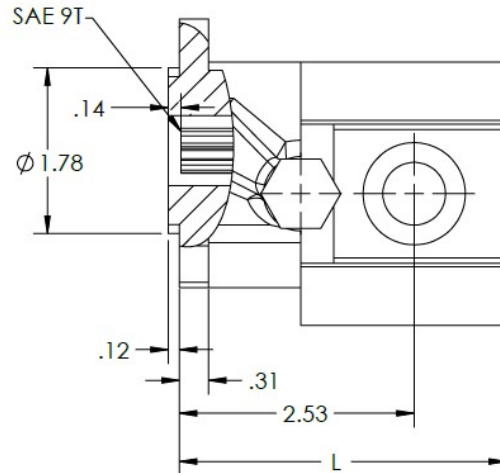
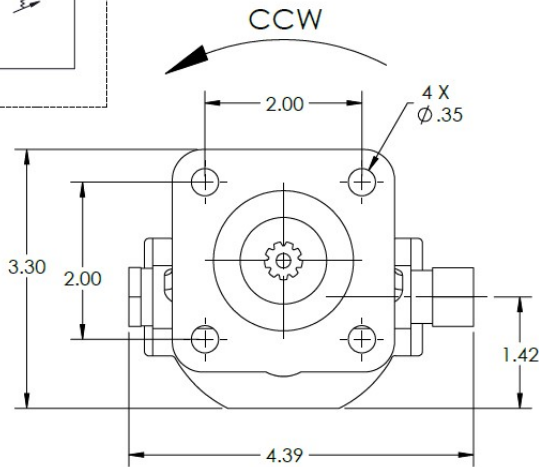
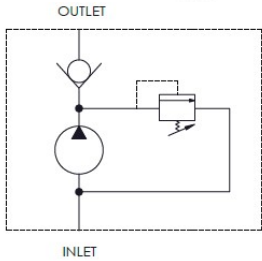

\*Dimensions are subject to change based on final configuration

PART NO.	DISPLACEMENT in <sup>3</sup> /r (mL/r)	PRESSURE (Bar/PSI)		L (in)	INLET	OUTLET
		RATE	MAX			
CBS-F2.1F	0.1281 (2.10)	160 / 2320	210 / 3045	3.43	SAE #8 3/4-16	SAE #6 9/16-18
CBS-F3.0F	0.1831 (3.00)	160 / 2320	210 / 3045	3.57		
CBS-F3.5F	0.2136 (3.42)	160 / 2320	210 / 3045	3.64		
CBS-F4.0F	0.2441 (4.00)	160 / 2320	210 / 3045	3.73		
CBS-F5.0F	0.3051 (5.00)	160 / 2320	210 / 3045	3.80		

**PERFORMANCE:**

1. DISPLACEMENT: 0.1281-0.3051 in<sup>3</sup>/r.
2. WORKING PRESSURE: 2320 PSI, MAX PRESSURE: 3045 PSI
3. ROTATING SPEED: 2000-3450 rpm
4. ROTATION DIRECTION: COUNTERCLOCKWISE

\* All pumps above are 9-tooth male spline shafts (SAE 9T)

\* Also available with other modifications - Please contact KTI for more details

KTI manifolds are stackable to create functionally diverse circuits. Each manifold consists of (1) double acting circuit with or without load holding capabilities.

- Can be mounted on UM-I to create different circuits.
- Ability to create double acting circuits with AC
- Ability to mount remotely down stream if needed
- Also available with flow control valves

All connection ports are SAE #6 (9/16 - 18) O-ring ports

All Pressure and Tank ports ( P & T ) are SAE #4 (7/16 - 20) O-ring ports

All Utilization ports ( A & B ) are SAE #6 O-ring ports

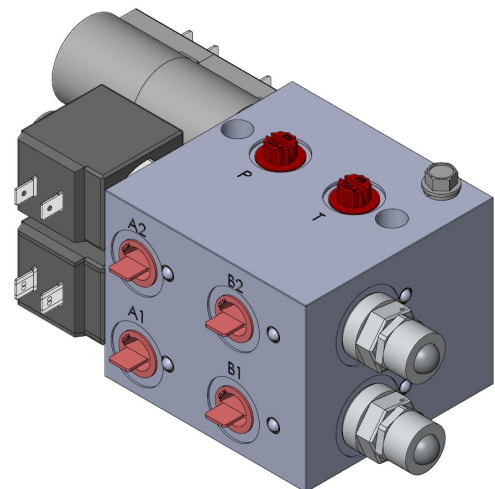
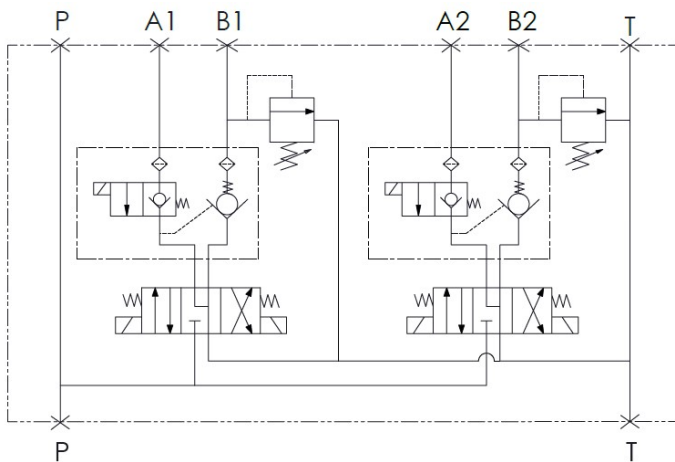
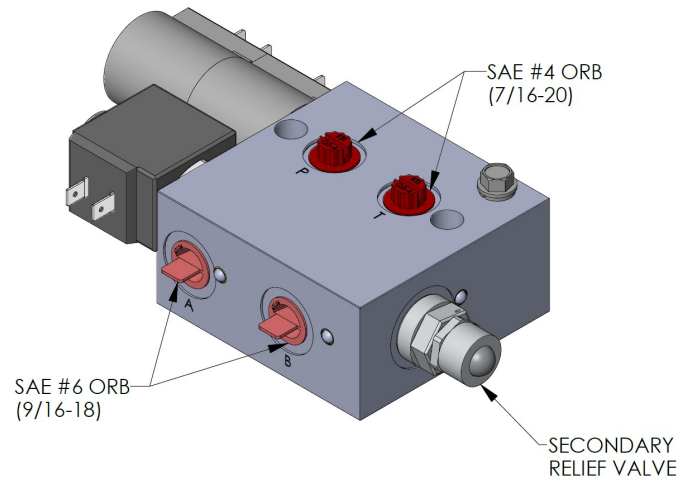
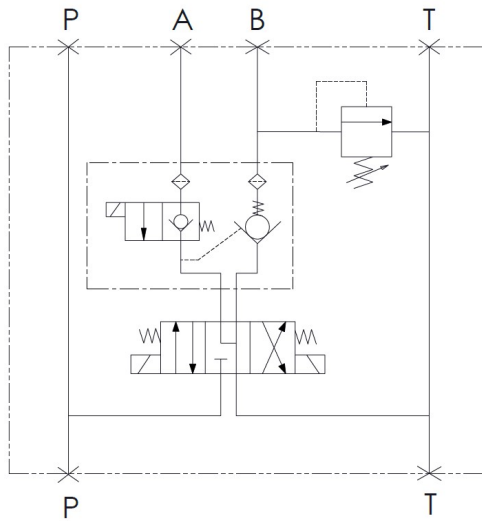

# VALVE PACKS

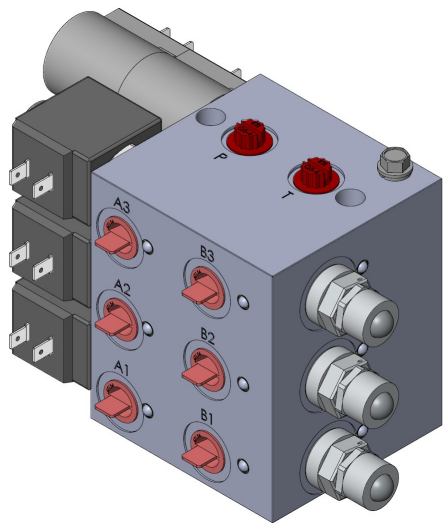
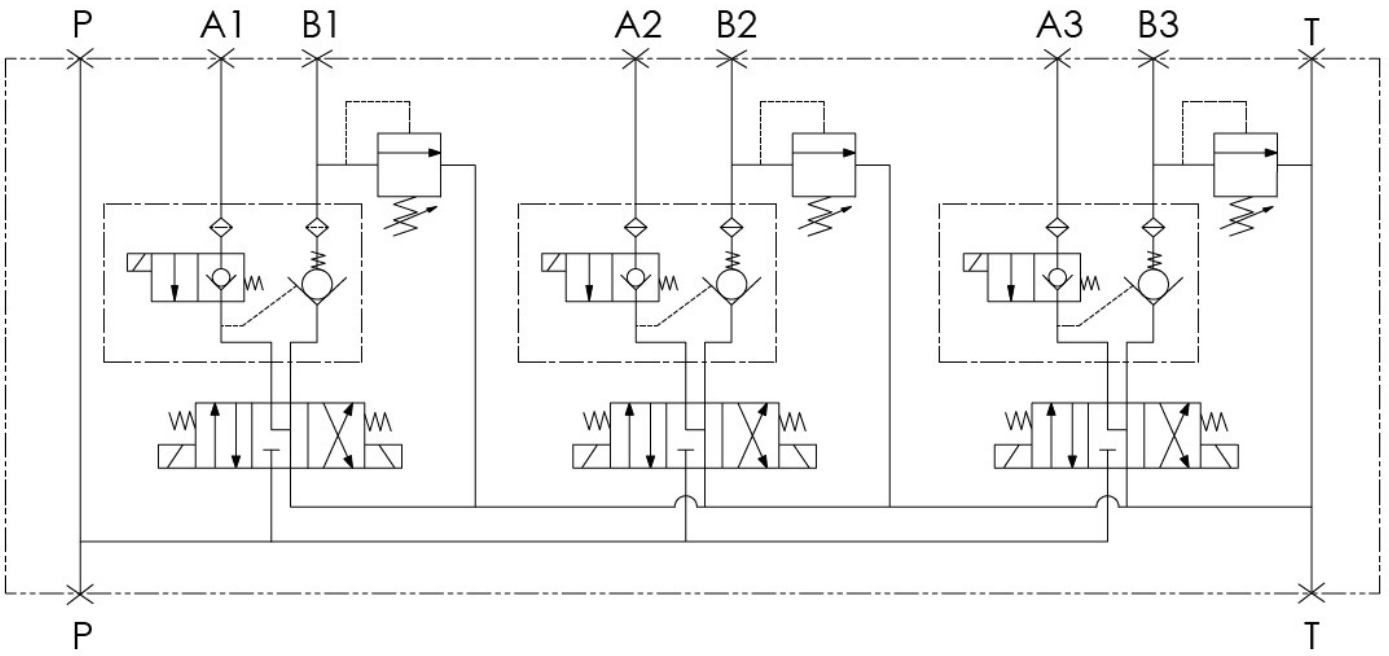

# KTI FDA SERIES GEAR TYPE FLOW DIVIDERS

## OVERVIEW

KTI Hydraulics Inc. FDA series gear type flow dividers. These flow dividers take a single hydraulic input, and divides the output into 2 or more equal circuits. Integrated rephrasing valve is standard on all FDA flow dividers. Also available as cartridge style.

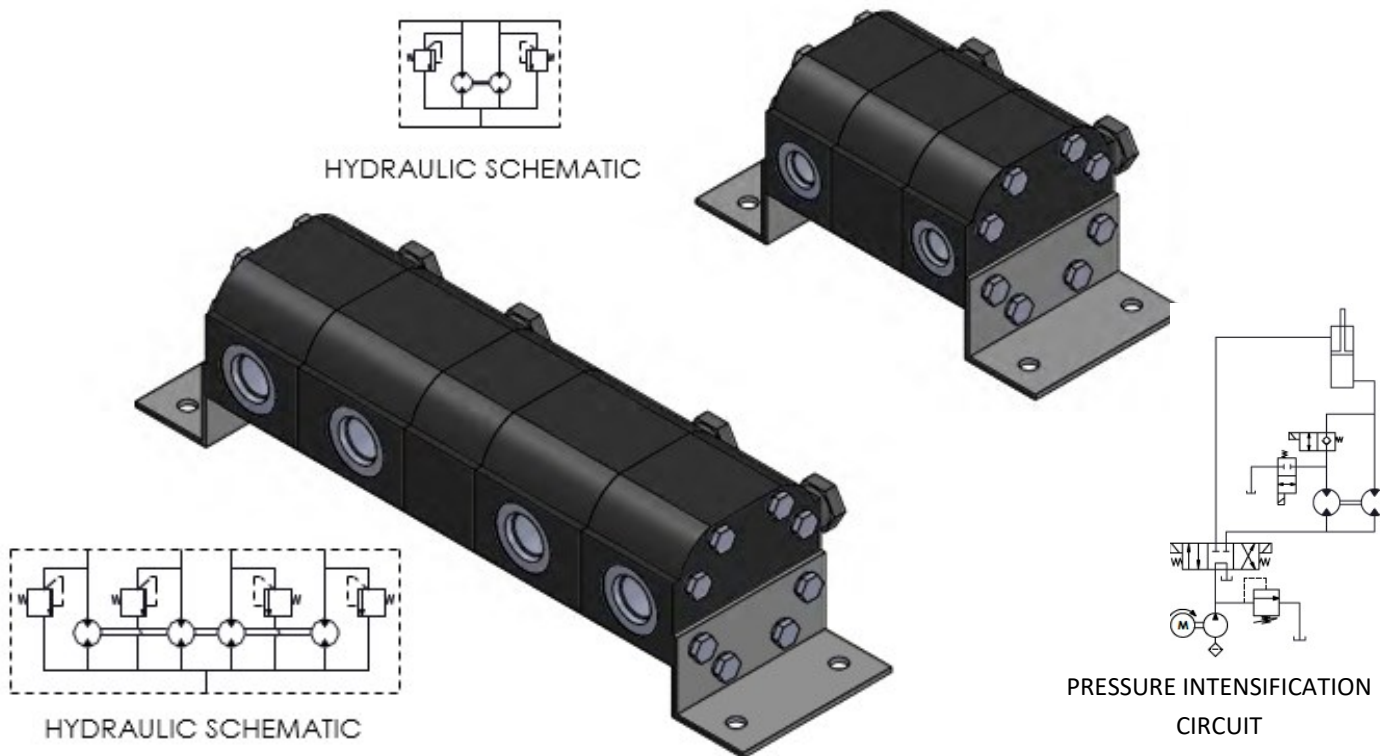

PART NO.	DISPLACEMENT PER SECTION	MIN. INLET FLOW	STANDARD INLET FLOW	MAX. INLET FLOW	MAX. OUTLET PRESSURE	PORTS	
	IN <sup>3</sup>	750 RPM (IN <sup>3</sup> /MIN)	1500 RPM (IN <sup>3</sup> /MIN)	3000 RPM (IN <sup>3</sup> /MIN)	PSI	SAE INLET	SAE OUTLET
FDA-2R1.0S	0.0610	92	183	366	3625	3/4-3-16	9/16-18
FDA-2R2.1S	0.1281	192	384	769			
FDA-2R3.0S	0.1831	275	549	1099			
FDA-2R4.2S	0.2650	398	795	1590		7/8-14	3/4-16
FDA-2R5.0S	0.3051	458	915	1831			
FDA-2R6.3S	0.3844	577	1153	2306			
FDA-2R8.8S	0.5380	807	1614	3228	3046	3/4-16	9/16-18
FDA-4R2.1S	0.1281	384	769	1537			
FDA-4R3.0S	0.1831	549	1099	2197			
FDA-4R4.2S	0.2650	795	1590	3180		7/8-14	3/4-16
FDA-4R5.0S	0.3051	915	1831	3661			
FDA-4R6.3S	0.3884	1165	2330	4661			
FDA-4R8.8S	0.5380	1614	3228	6456			

## RESERVOIRS

### STEEL DEEP DRAW

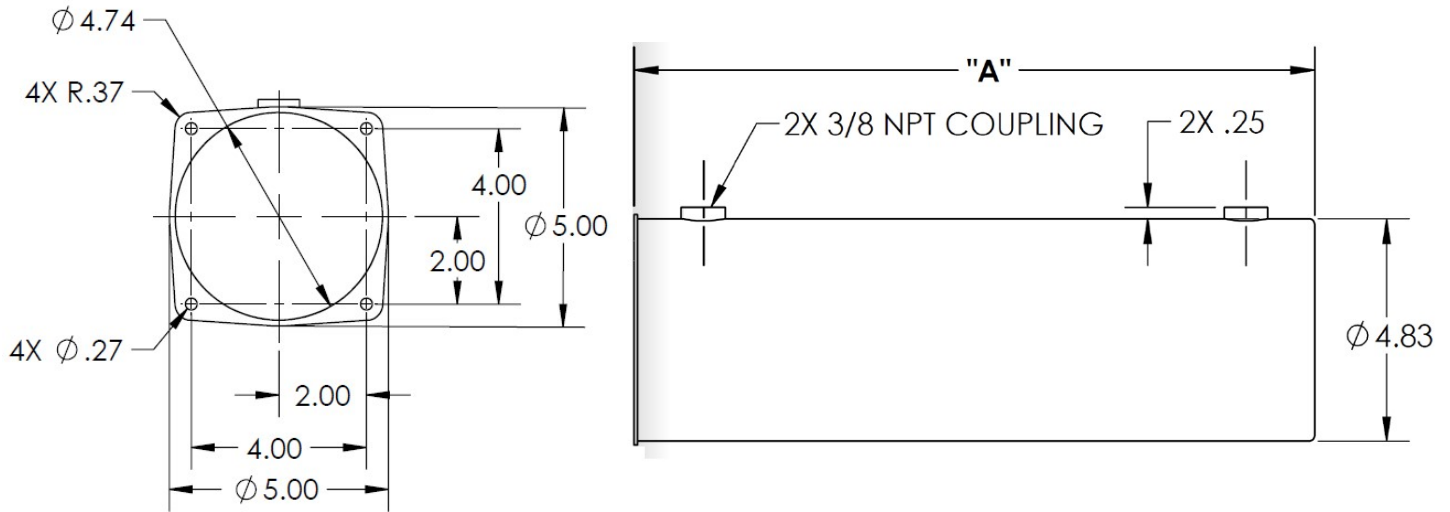

Order Letter	PART NO.	USABLE VOLUME (HORIZONTAL)	LENGTH "A" (in.)
K	8080-21	1.5 QT	6.25
A	8080-2	2.0 QT	8.38
B	8080-3	3.0 QT	11.50
C	8080-4	4.0 QT	14.88

### STEEL OFFSET

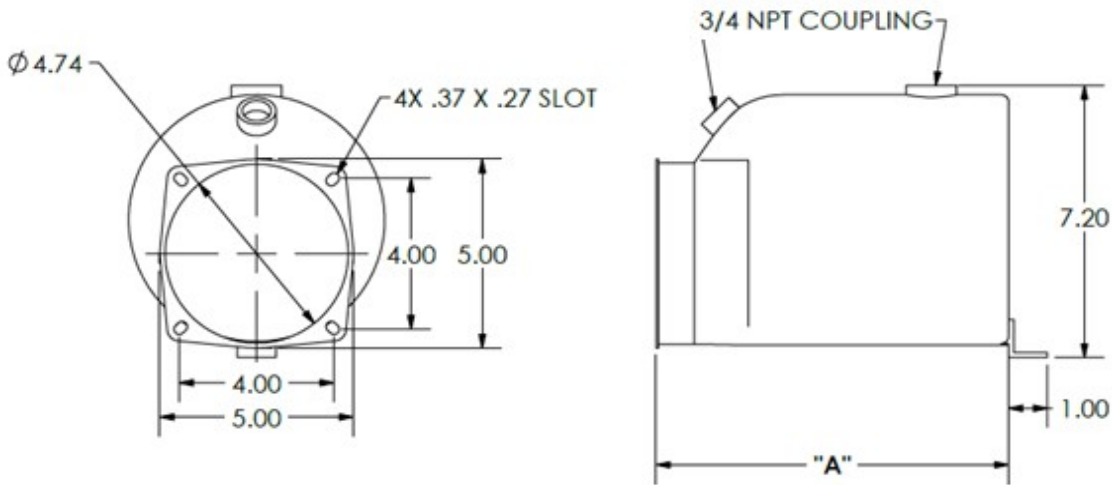

Order Letter	PART NO.	USABLE VOLUME	LENGTH "A" (in.)
D	8080-5	4 QT	9.13
E	8080-6	6 QT	12.50
F	8080-8	8 QT	15.88
G	8080-10	10 QT	19.25
H	8080-12	12 QT	21.50



## RESERVOIRS

### STEEL SQUARE

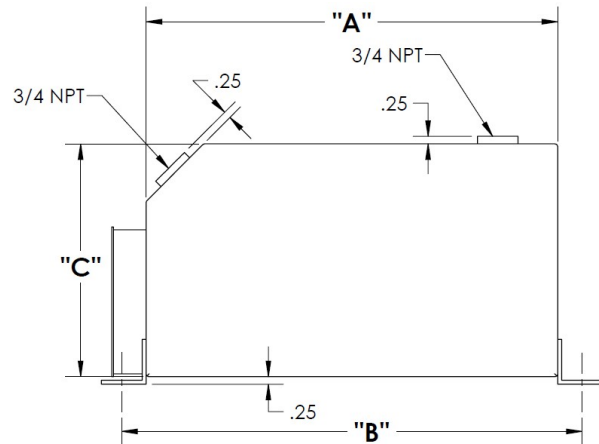
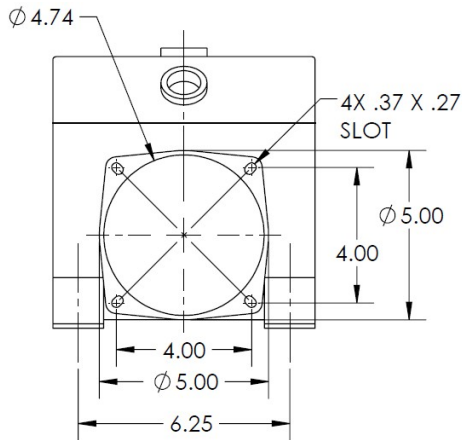

Order Letter	PART NO.	USABLE VOLUME HORIZONTAL	LENGTH "A" (in.)	LENGTH "B" (in.)	LENGTH "C" (in.)
U	8080-8-S	8 QT (2 GALLON)	9.24	10.74	8.00
L	8080-13	12 QT ( 3 GALLON)	13.75	15.25	8.00
M	8080-16	16 QT (4 GALLON)	18.5	20.00	8.00
N	8080-20	20 QT (5 GALLON)	22.88	24.38	8.00
W	8080-24	24 QT (6 GALLON)	22.88	24.38	9.75
V	8080-3318	28 QT (7 GALLON)	Overall dimension 12" x 12" x 12"		

\* No mounting feet - Overall tank width

### PLASTIC SQUARE

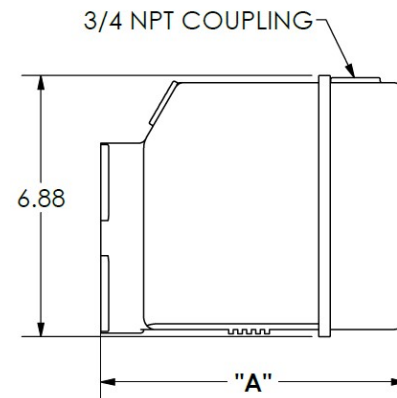
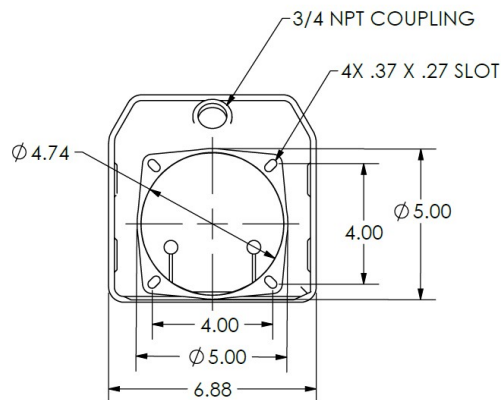

Order Letter	PART NO.	USABLE VOLUME HORIZONTAL	LENGTH "A" (in.)
I	8181-35	3 QT	8.00
O	8181-5	4 QT	10.50
P	8181-6	6 QT	13.25
Q	8282-8	8 QT	17.32
R	8282-10	10 QT	20.00
J	8181-14	14 QT	24.88
T	8282-16	16 QT	27.50

## RESERVOIRS

### PLASTIC SQUARE

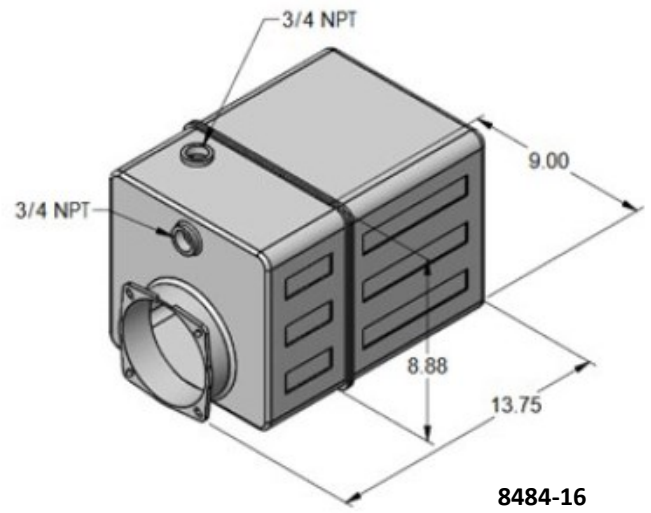
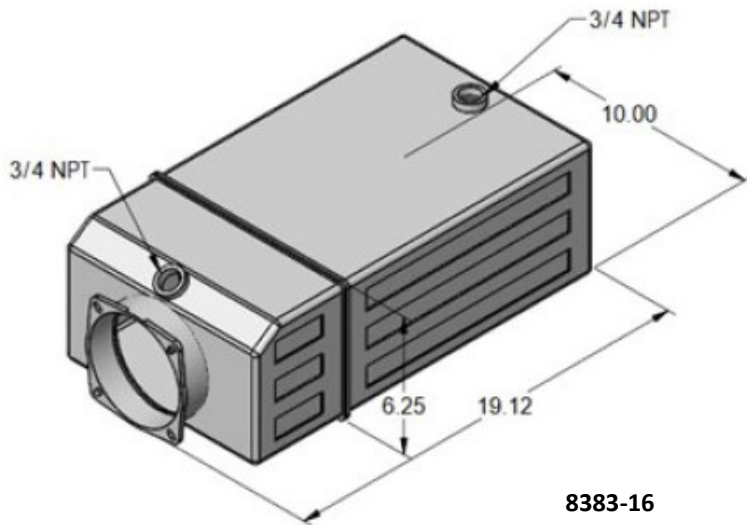

Order Letter	PART NO.	USABLE VOLUME (HORIZONTAL)
S	8383-16	16 QT (4.00 GALLON)
W	8484-16	12.25 QT (3.06 GALLON)

## CONTROLLERS

# WIRELESS REMOTE CONTROLLER - KWR-004

## OVERVIEW

4-Function wireless receiver that works with any KTI Power Unit built after January 2015. Wireless remote has a range of about 40 ft with no obstructions. Has a built-in sleep mode that shuts down after being idle for 20 minutes.

## PRODUCT DETAILS

- Detachable Antenna Cord: 38"
- Kit includes: 4-Function wireless receiver; 4-Button wireless transmitter (remote comes preprogrammed)

\* For wireless to work on units prior to 2015, please contact factory for details. Refer to KWR-004-K & KWR-004-K1 in selection table below.

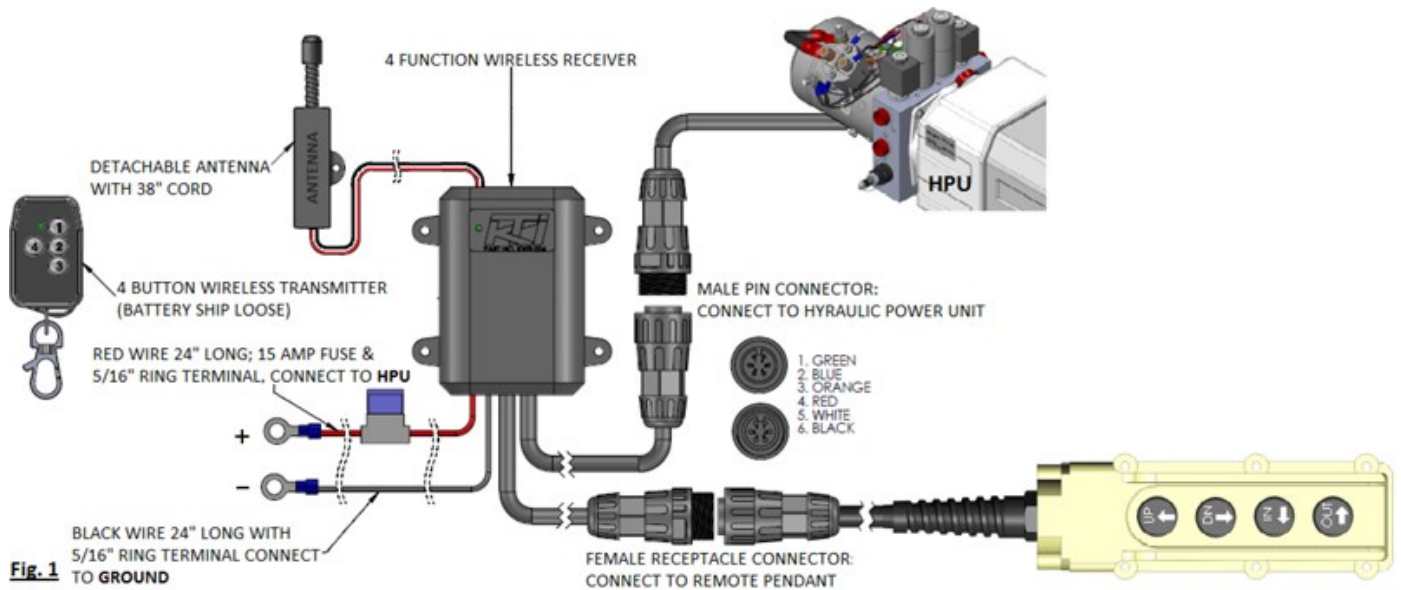

PART NUMBER	DESCRIPTION
KWR-004	4-Function Wireless Remote
KWR-004-K	4-Function Wireless Remote for Dual Double Acting Function Power Unit - Complete Retro Fit
KWR-004-K1	4-Function Wireless Remote for dual double acting function power unit - wiring harness with quick connector

## CONTROLLERS

# BLUETOOTH / WIRELESS REMOTE CONTROLLER - KWR-005 & KWR-006

## OVERVIEW

Bluetooth wireless controller for trailers built after January 2015 with a KTI power unit. The KWR controller can be operated with the provided key fob or from a compatible Android or Apple device installed with the complimentary KTI Bluetooth application. The application also provides a battery voltage readout to allow the user to monitor the battery charge levels. The wireless range is roughly 30 feet depending on antenna location and surrounding obstructions. Receiver has a built in sleep mode shutdown feature after 20 minutes of inactivity.

## PRODUCT DETAILS

- One receiver can pair with up to 4 key fobs
- Includes an inline 15 amp fuse on the power wire for protection
- 5/16" eyes are included on power and ground wires to ease installation to battery
- Kit includes: 1x main transmitter, 1x 23 AE battery (for transmitter), 1x main receiver Unit, 1x detachable antenna, 1x antenna mounting screw, 2" by 2" Velcro, 1x installation manual

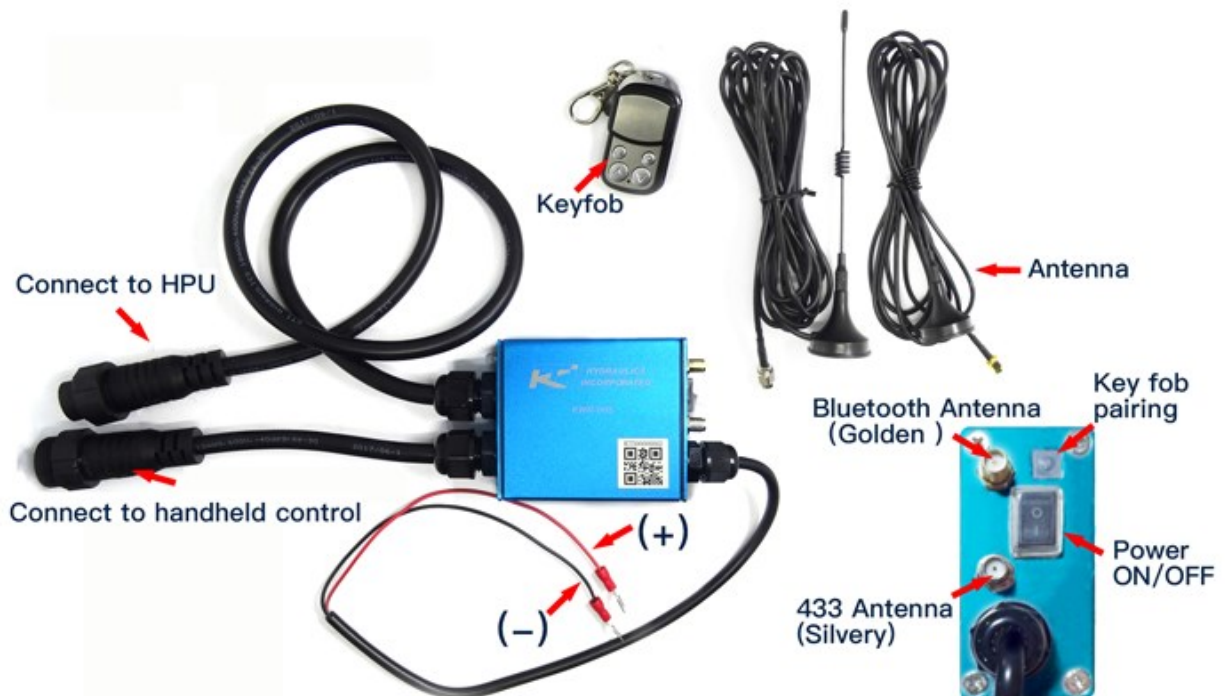

PART NUMBER	DESCRIPTION
KWR-005	Bluetooth / Wireless Remote Set. Includes two button transmitter. Works on a single channel. For four pin connectors.
KWR-006	Bluetooth / Wireless Remote Set. Includes four button transmitter. Works on a dual channel. For six pin connectors.

## Power Unit Installation Recommendations

- 1) To avoid contamination, do not remove plastic port plugs until fittings are to be installed.
- 2) Power Unit mounting flange must make full contact with equipment mount; do not use the mounting bolts to force alignment of the power unit on to the equipment mount.
- 3) If pump fails to prime, remove Cartridge Check Valve, and start the power unit until hydraulic oil flows from the valve cavity and reinstall the Cartridge Check Valve. (*does not apply to double acting units*)
- 4) Fluid Temperature should not exceed 150°F, System reliability and component service life will be reduced

### INLET CONDITIONS

Positive pressure must be available at the pump inlet while it is operating. Overrunning load can cause the pump to cavitate. Consult the factory for inlet pressure requirements and speed limitation.

### FILTRATION

For maximum pump and system component life, the system should be protected from contamination at a level not to exceed 125 particles greater than 10 microns per milliliter of fluid (SAE Class 4 / ISO 16/13).

### SERVICE

- 1) Clean fluid essential to system reliability and longer component service life.
- 2) It is recommended that for every 4,000 operating hours or once a year, whichever occurs first, the air filter / breather cap and suction strainer should be replaced or thoroughly cleaned
- 3) Every 4,000 operating hours, or once a year, whichever occurs first - Drain hydraulic oil from reservoir and remove reservoir from Manifold (end plate). Use WD-40 or similar product to wipe down and remove all debris inside the reservoir, also check the magnet for signs of metal particles. Lubricate reservoir O-ring with hydraulic fluid to remount the reservoir. Ensure reservoir O-ring is not pinched or pushed out of groove during installation.
- 4) For TEFC motors, remove fan casing and wipe fan blade and casing
- 5) For other service, please consult factory for proper procedures



## Fluid Recommendations

KTI Hydraulics Inc. recommends using a premium hydraulic oil to ensure optimum performance and system life.

Select oil that has anti-wear properties, rust and oxidation inhibitors, foam inhibitors and good stability. Examples of premium grade hydraulic oils:

- Chevron Rando HDZ
- Bel-Ray Premium AW 32
- Mobil DTE 10 and DTE 20 series
- AMSOIL
- Shell Tellus.

Automotive Transmission Oils are acceptable under normal conditions.

Aviation oils such as Valvoline, ROYCO series, or Mobil Aero HF or HFA (MIL-H 5606 or MIL-PRF-83282) may be used in **prolonged & extreme cold** environments.

Ambient Temperature Range	ISO Viscosity Grade
-20°F to +32°F (-29°C to +0°C)	15
-14°F to +120°F (-10°C to +49°C)	22, 32, ATF
Extreme Prolonged Environments	MIL-H 5606

Do Not Use Biodegradable Hydraulic Fluid. Do Not Mix Oils.

Do not operate Power Unit above recommended Fluid Temperature Range.

Premium hydraulic oil with proper ISO Viscosity Grade and additives such as Chevron EP, Mobile DTE 10, DTE 20 series, or Shell Tellus would be acceptable.

In most applications use ATF Dextron III.

## Limited Warranty and Return Goods Authorization (RGA) Procedures

KTI Hydraulics Inc. warrants its products to be free from material defects, workmanship, and design for a period of **two years after date of manufacture on DC Units** and **one year from date of manufacture on AC Units**.

Under no circumstances is there any warranty for fitness for a particular use. KTI Hydraulics will not accept responsibility for any products made by KTI Hydraulics that have been subjected to improper installation, application, negligence, tampering or abuse. All repairs must be authorized by KTI Hydraulics to reduce the risk of bodily harm and warranty violation. KTI liability & warranty shall extend only to replacement or correction, f.o.b. KTI Hydraulics.

KTI Hydraulics does not acknowledge any warranty claims for damages resulting from improper use by buyer or user. KTI Hydraulics liability is limited to the product sold and is only obligated to repair or replace defective parts.

**For warranty information or warranty request please contact Customer Service:**

**KTI Main Office:** (949) 752-8818

**Email:** [service@kti hydraulicsinc.com](mailto:service@kti hydraulicsinc.com)

Power units without model number & serial numbers will not be covered under warranty, when calling please have the model and serial numbers available.

### Return Goods Authorization (RGA) Procedures

The following requirements must be followed by the Buyer when returning goods for warranty consideration.

- 1) Warranty request must be made via written, e-mail, voice by Buyer to KTI Hydraulics, Inc. with the following information:
  - a. KTI Hydraulics Model Number, Part Number & Serial Number.
  - b. If the Model or Serial Number are not available, they may be found by cross reference through Buyer's P.O or KTI Hydraulics invoice number.
  - c. Quantities of unit or units under question.
  - d. Reason for return i.e. defect, warranty, or repair with suspected reasons for failure.
- 2) KTI Hydraulics, Inc will issue a RGA number then fax an RGA form with the number to the Buyer. All corresponding paper work will reference this RGA number.
- 3) All RGA numbers are effective for 60 days from the issuing date. Buyer has the responsibility to ensure proper documentation (item d), proper packaging and shipping on prepaid basis unless obtaining prior written authorization from KTI Hydraulics. Return goods shipped to KTI freight collect, or C.O.D. will result in KTI Hydraulics refusal of shipment. Return goods received by KTI Hydraulics after 60 days will be subjected to repair charges. KTI Hydraulics will take possession of said returned goods when it arrives at KTI Hydraulics premise. KTI Hydraulics will not be responsible for any extraneous parts that are not manufactured or sold by KTI Hydraulics.

## Limited Warranty (continued)

### Not Covered Under Warranty

KTI Hydraulics will not accept any responsibility of any type for its products that have been subjected to improper installation, application, negligence, tampering or abuse.

The following are reasons why KTI Hydraulics does not cover under warranty

- 1) **Improper Installation:** Example is over torquing fasteners during installation which may result in damage to the power unit. KTI does not accept responsibility for damage to its product under such circumstances.
- 2) **Improper Application:** KTI does not accept responsibility for any units that have been improperly specified due to lack of information pertaining to the specific application.  
*Example:* if an application requires a water sealed motor and the requirement was not specified, KTI is not accountable for the motor's failure when exposed to water and subsequent corrosion or rust. KTI relies on customer to provide all information relating to the application such as its exposure or enclosure as to where unit will be mounted.
- 3) **Negligence:** KTI will not take responsibility for any product neglected by customer. Such as customer leaves box to trailer open and unit gets wet resulting in failure of motor or valves due to the corrosion or rust, Customer neglected to service on unit resulting in sever contamination to unit.
- 4) **Tampering:** Units that have been tampered with modified to other than factory settings will not be considered for warranty. All relief valves are factory pre-set. Any adjusting or tampering can result in severe injury or even death. Units adjusted in field can result in burning up of solenoids, motors and coils in which KTI does not take responsibility for. Any adjustments in field must be approved by KTI via written email or fax.
- 5) **Abuse:** KTI stands behind their products one hundred percent. All products are tested before shipping. Any abuse to products will not be considered for warranty. The following are considered abuse per KTI standards:
  - **Low Voltage:** If the battery is not properly charged it can result in high amp draw. High amps can burn electrical components such as solenoids, coils, motors, and contacts in the hand control.
  - **Contamination:** Contaminates in the system can cause valve failure and pump failure. Contaminates can also lead to cylinder failure.
  - **Rust** – Water in the hydraulic fluid can cause improper valve spool operation, corrosion and seizure of the pump, and/or motor.
  - **Improper Fluid:** The wrong viscosity grade can cause the pump/motor to bog down resulting in high amp draw. High amp draw can burn the motor and other electrical components.

# **Bleed Cycle – Dump Trailer**

## **How to perform the Bleed Cycle on your KTI Hydraulic Power Unit:**

Remove the breather cap, so you may view the hydraulic fluid level while operating the Hydraulic Power Unit. Verify fluid connections are tight. Begin to run the power unit to extend the cylinder, monitor the fluid level and make sure it doesn't fall below half of the tank volume. Once the cylinder is fully extended, continue running the unit for 5-10 seconds bleeding over the relief valve. Re-verify fluid level and retract the cylinder. Repeat until smooth operation occurs to completely purge all of the air out of the system.

For double acting cylinder, repeat the same process listed above for both power up and power down. If the fluid becomes to aerated or foams, wait 10 minutes or until fluid appears normal again to continue the bleeding process.

**\*Please ensure that the fluid level does not get below half while running the power unit**

**\*Please be sure to recharge the battery after this cycle as it will consume a considerable amount of energy**

**\*Please make sure the dump bed is lowered all the way down or secured on a safety prop when disconnecting any hose connection or removing any valve from the cylinder or power unit**

If you have any questions, please feel free to contact us at:

**KTI Main Office:** (949) 752-8818

**Email:** [service@kti hydraulicsinc.com](mailto:service@kti hydraulicsinc.com)

