

# ORDER CATALOG

## CASTERS AND WHEELS

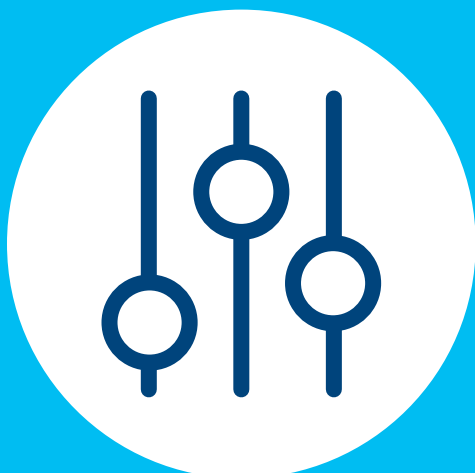

BETTER MOBILITY. BETTER LIFE.



# INDEX

## BESTWAY

General .....	1
---------------	---

## INDUSTRIAL CASTERS

BH bolt hole series.....	4
RT/RTR round top plate series.....	6
HK/HKR Husky series .....	9
LX/LXR series .....	11
GP/GPR General Purpose series .....	13
BW/BWR Bestway series .....	15
LD/LDR Kingboltless series .....	20
HD/HDR series .....	23
LH/LHR series.....	25
LE/LER Kingboltless series .....	26
LS/LSR Kingboltless series.....	28
SX/SXR Kingboltless series.....	30
KP/KPR Kingboltless series.....	32
IH/IHR Kingboltless series.....	34
Air free casters.....	35
TWLE/TWLER Twin-wheel Kingboltless series .....	37
TWIH/TWIHR Twin-wheel Kingboltless series .....	39

## STAINLESS STEEL CASTERS

SSLX/SSLXR series .....	42
SSGP/SSGPR series .....	43
SSBH series .....	45
SS/SSR series.....	47
SSRT/SSRTR series.....	49
SSLD/SSLDR series .....	51
SSHD/SSHDR series.....	53
SSLE/SSLER series .....	55
SSLS/SSLSR series.....	57

## SPECIALTY CASTERS & ACCESSORIES

Brake types .....	60
Floor locks.....	61
Swivel mechanisms.....	63
Ladder, door and gate casters.....	64
Ball transfers and skate wheels .....	65

## FITTINGS

Stems.....	67
Top plates .....	68

## REPLACEMENT WHEELS

Phenolic.....	79
Monolithic .....	81
Cast steel, ductile iron, steel and stainless steel.....	82
Urethane.....	88
Rubber .....	95
Polyolefin .....	98
Nylon .....	100
PAL series pallet.....	101

## REPLACEMENT PARTS

Bearings.....	104
Top hat bushings.....	105
Bearings, washers and seals .....	106
Spanner bushings .....	107
Axle kits .....	108



Bereitstellzone

**F**

Bereitstellzone

**E**

**12**

**1**

ben  
ben  
ben

# INDUSTRIAL CASTERS

BH bolt hole series	4
RT/RTR round top plate series	6
HK/HKR Husky series	9
LX/LXR series	11
GP/GPR General Purpose series	13
BW/BWR Bestway series	15
LD/LDR Kingboltless series	20
HD/HDR series	23
LH/LHR series	25
LE/LER Kingboltless series	26
LS/LSR Kingboltless series	28
SX/SXR Kingboltless series	30
KP/KPR Kingboltless series	32
IH/IHR Kingboltless series	34
Air free casters	35
TWLE/TWLER Twin-wheel Kingboltless series	37
TWIH/TWIHR Twin-wheel Kingboltless series	39

# BH BOLT HOLE SERIES

500 lbs maximum capacity

## BH swivel casters

This medium-duty bolthole caster offers the same high quality construction as our very popular GP Series. The optional total lock brake which locks both the wheel and swivel with one push of the pedal makes this an ideal multi-purpose caster. A wide variety of standard or custom stems are available from our machine shop to make mounting easy whatever your application. Double ball race construction and zinc plating are standard. Also available in [stainless steel](#).



BH-4125-EL-BB  
BH STEM: 7/8" x 2" SC

Order number	Tread width	Wheel type	Bolt size	Overall height	Swivel radius	Bearing type	Load cap.
<b>3" Ø wheels</b>							
BH-3125-BAL	1-1/4"	Phenolic	12.2mm	4"	3"	Plain	300
BH-3125-BST	1-1/4"	Cast Steel	12.2mm	4"	3"	Plain	300
BH-3125-UN-BB	1-1/4"	Star-Tech Urethane	12.2mm	4"	3"	Ball Bearing	250
BH-3125-MR	1-1/4"	Multi-Purpose Rubber	12.2mm	4"	3"	Plain	210
BH-3125-EL-BB	1-1/4"	Eliminator Grey Rubber	12.2mm	4"	3"	Ball Bearing	200
BH-3125-NL	1-1/4"	Ny-Lite	12.2mm	4"	3"	Plain	275
BH-3125-WNL	1-1/4"	White Poly-Olefin	12.2mm	4"	3"	Plain	275
BH-3150-BAL-RB	1-1/2"	Phenolic	12.2mm	4"	3"	Roller	300
BH-3150-BST-RB	1-1/2"	Cast Steel	12.2mm	4"	3"	Roller	300
BH-3150-UC-RB	1-1/2"	Urethane on Cast	12.2mm	4"	3"	Roller	300
BH-3150C-ES-HRB	1-1/2"	Solid Elastomer [Crowned]	12.2mm	4"	3"	HD Roller	300
BH-3150-NY-RB	1-1/2"	White Nylon	12.2mm	4"	3"	Roller	300
BH-3150C-EAS-PBB	1-1/2"	Anti-Static Elastomer	12.2mm	4"	3"	Precision Ball	300
BH-080-HTM-HL	35mm	Hi-Temp Monolithic	12.2mm	4"	3"	Hi-Lex	220
<b>4" Ø wheels</b>							
BH-4125-BAL	1-1/4"	Phenolic	12.2mm	4-15/16"	3-1/2"	Plain	300
BH-4125-BST	1-1/4"	Cast Steel	12.2mm	4-15/16"	3-1/2"	Plain	350
BH-4125-UN-BB	1-1/4"	Star-Tech Urethane	12.2mm	4-15/16"	3-1/2"	Ball Bearing	250
BH-4125-EL-BB	1-1/4"	Eliminator Grey Rubber	12.2mm	4-15/16"	3-1/2"	Ball Bearing	220
BH-4125-NL	1-1/4"	Ny-Lite	12.2mm	4-15/16"	3-1/2"	Plain	300
BH-4125-WNL	1-1/4"	White Poly-Olefin	12.2mm	4-15/16"	3-1/2"	Plain	300
BH-4125-MR	1-1/4"	Multi-Purpose Rubber	12.2mm	4-15/16"	3-1/2"	Plain	300
BH-4150-BAL-RB	1-1/2"	Phenolic	12.2mm	4-15/16"	3-1/2"	Roller	350
BH-4150-HT-RB	1-1/2"	Hi-Temp Phenolic	12.2mm	4-15/16"	3-1/2"	Roller	350
BH-4150-BST	1-1/2"	Cast Steel	12.2mm	4-15/16"	3-1/2"	Plain	350
BH-4150-BST-RB	1-1/2"	Cast Steel	12.2mm	4-15/16"	3-1/2"	Roller	350
BH-4150-UN-RB	1-1/2"	Star-Tech Urethane	12.2mm	4-15/16"	3-1/2"	Roller	350
BH-4150-UC-RB	1-1/2"	Urethane on Cast	12.2mm	4-15/16"	3-1/2"	Roller	350
BH-4150C-ES-HRB	1-1/2"	Solid Elastomer [Crowned]	12.2mm	4-15/16"	3-1/2"	HD Roller	350
BH-4150-MR-RB	1-1/2"	Multi-Purpose Rubber	12.2mm	4-15/16"	3-1/2"	Roller	350
BH-4150-EL-RB	1-1/2"	Eliminator Grey Rubber	12.2mm	4-15/16"	3-1/2"	Roller	350
BH-4150-RMC-RB	1-1/2"	Rubber Moldon [H90]	12.2mm	4-15/16"	3-1/2"	Roller	350
BH-4150-NL-RB	1-1/2"	Ny-Lite	12.2mm	4-15/16"	3-1/2"	Roller	350
BH-4150-NY-RB	1-1/2"	White Nylon	12.2mm	4-15/16"	3-1/2"	Roller	350
BH-4150C-EAS-PBB	1-1/2"	Anti-Static Elastomer	12.2mm	4-15/16"	3-1/2"	Precision Ball	350
BH-100-HTM-HL	35mm	Hi-Temp Monolithic	12.2mm	4-15/16"	3-1/2"	Hi-Lex	275

## Options

[1] For total lock brake add code 'TLB' to order number. [example: BH/TLB-5150-EL-RB]

[2] Delrin bearing. Substitute 'DEL' for 'RB' or 'BB' in order number. [example: BH-3150-BAL-DEL]

[3] See page 68 for stem options or contact us for custom stems.

**Note:** Listed capacities are for casters only [without stems]. Some stems may reduce the above listed capacities. Contact us.

# BH BOLT HOLE SERIES

500 lbs maximum capacity

## BH swivel casters

This medium-duty bolthole caster offers the same high quality construction as our very popular GP Series. The optional total lock brake which locks both the wheel and swivel with one push of the pedal makes this an ideal multi-purpose caster. A wide variety of standard or custom stems are available from our machine shop to make mounting easy whatever your application. Double ball race construction and zinc plating are standard. Also available in [stainless steel](#).



BH/TLB-4150-NL-RB

Order number	Tread width	Wheel type	Bolt size	Overall height	Swivel radius	Bearing type	Load cap.
<b>5" ø wheels</b>							
BH-5150-BAL-RB	1-1/2"	Phenolic	12.2mm	6"	4-1/4"	Roller	450
BH-5150-BST-RB	1-1/2"	Cast Steel	12.2mm	6"	4-1/4"	Roller	450
BH-5150-UN-RB	1-1/2"	Star-Tech Urethane	12.2mm	6"	4-1/4"	Roller	450
BH-5150-UC-RB	1-1/2"	Urethane on Cast	12.2mm	6"	4-1/4"	Roller	450
BH-5150C-ES-HRB	1-1/2"	Solid Elastomer [Crowned]	12.2mm	6"	4-1/4"	HD Roller	450
BH-5150-MR-RB	1-1/2"	Multi-Purpose Rubber	12.2mm	6"	4-1/4"	Roller	450
BH-5150-EL-RB	1-1/2"	Eliminator Grey Rubber	12.2mm	6"	4-1/4"	Roller	400
BH-5150-RMC-RB	1-1/2"	Rubber Moldon [H90]	12.2mm	6"	4-1/4"	Roller	450
BH-5150-NL-RB	1-1/2"	Ny-Lite	12.2mm	6"	4-1/4"	Roller	450
BH-5150-NY-RB	1-1/2"	White Nylon	12.2mm	6"	4-1/4"	Roller	450
BH-5150C-EAS-PBB	1-1/2"	Anti-Static Elastomer	12.2mm	6"	4-1/4"	Precision Ball	450
BH-125-HTM-HL	40mm	Hi-Temp Monolithic	12.2mm	6"	4-1/4"	Hi-Lex	330
<b>6" ø wheels</b>							
BH-6150-BAL-RB	1-1/2"	Phenolic	12.2mm	7"	4-3/4"	Roller	500
BH-6150-UN-RB	1-1/2"	Star-Tech Urethane	12.2mm	7"	4-3/4"	Roller	500
BH-6150-UC-RB	1-1/2"	Urethane on Cast	12.2mm	7"	4-3/4"	Roller	500
BH-6150-MR-RB	1-1/2"	Multi-Purpose Rubber	12.2mm	7"	4-3/4"	Roller	500
BH-6150-EL-RB	1-1/2"	Eliminator Grey Rubber	12.2mm	7"	4-3/4"	Roller	500
BH-6150-RMC-RB	1-1/2"	Rubber Moldon [H90]	12.2mm	7"	4-3/4"	Roller	500
BH-6150-NL-RB	1-1/2"	Ny-Lite	12.2mm	7"	4-3/4"	Roller	500
BH-6150-NY-RB	1-1/2"	White Nylon	12.2mm	7"	4-3/4"	Roller	500

# RT/RTR ROUND TOP PLATE SERIES

700 lbs maximum capacity

## RT swivel casters and RTR rigid casters

The RT Series uses the same high quality construction as our signature Bestway series in a stem caster. Our wide selection of standard and custom stems mean that this caster can be mounted in virtually any application. Equipped with 5/8" kingpin construction, 1/4" leg material, 3-1/4" round top plate, zinc plated finish and a large selection of wheel sizes. This is a truly exceptional product. North American made for fast delivery and competitive pricing. Fully customizable upon request. Also available in [stainless steel](#). Use 'RTR' instead of 'RT' in the order number when ordering RIGID casters.



RT-6200-ES-HRB  
RT STEM: 3/4"-10 x 4" TS

Order number	Tread width	Wheel type	Overall height	Swivel radius	Bearing type	Load cap.
<b>3" Ø wheels</b>						
RT-3150-BAL-RB	1-1/2"	Phenolic	4-3/8"	2-3/4"	Roller	500
RT-3150-BST-RB	1-1/2"	Cast Steel	4-3/8"	2-3/4"	Roller	500
RT-3150-UC-RB	1-1/2"	Urethane on Cast	4-3/8"	2-3/4"	Roller	400
RT-3150C-ES-HRB	1-1/2"	Solid Elastomer [Crowned]	4-3/8"	2-3/4"	HD Roller	350
RT-3150-RMC-RB	1-1/2"	Rubber Moldon [H90]	4-3/8"	2-3/4"	Roller	300
RT-3200-BAL-RB†	2"	Phenolic	4-1/2"	2-13/16"	Roller	600
RT-3200-BST-RB	2"	Cast Steel	4-3/8"	2-3/4"	Roller	600
RT-3200-UC-RB	2"	Urethane on Cast	4-3/8"	2-3/4"	Roller	540
<b>4" Ø wheels</b>						
RT-4150-BAL-RB	1-1/2"	Phenolic	5-5/8"	3-13/16"	Roller	500
RT-4150-HT-RB	1-1/2"	Hi-Temp Phenolic	5-5/8"	3-13/16"	Roller	400
RT-4150-BST	1-1/2"	Cast Steel	5-5/8"	3-13/16"	Plain	500
RT-4150-BST-RB	1-1/2"	Cast Steel	5-5/8"	3-13/16"	Roller	500
RT-4150-UN-RB	1-1/2"	Star-Tech Urethane	5-5/8"	3-13/16"	Roller	440
RT-4150-UC-RB	1-1/2"	Urethane on Cast	5-5/8"	3-13/16"	Roller	500
RT-4150C-ES-HRB	1-1/2"	Solid Elastomer [Crowned]	5-5/8"	3-13/16"	HD Roller	400
RT-4150-MR-RB	1-1/2"	Multi-Purpose Rubber	5-5/8"	3-13/16"	Roller	400
RT-4150-EL-RB	1-1/2"	Eliminator Grey Rubber	5-5/8"	3-13/16"	Roller	350
RT-4150-RMC-RB	1-1/2"	Rubber Moldon [H90]	5-5/8"	3-13/16"	Roller	500
RT-4150-NL-RB	1-1/2"	Ny-Lite	5-5/8"	3-13/16"	Roller	420
RT-4200-BAL-RB	2"	Phenolic	5-5/8"	3-13/16"	Roller	600
RT-4200-HT-RB	2"	Hi-Temp Phenolic	5-5/8"	3-13/16"	Roller	500
RT-4200-BST-RB	2"	Cast Steel	5-5/8"	3-13/16"	Roller	600
RT-4200-UN-RB	2"	Star-Tech Urethane	5-5/8"	3-13/16"	Roller	600
RT-4200-UC-RB	2"	Urethane on Cast	5-5/8"	3-13/16"	Roller	600
RT-4200C-ES-HRB	2"	Solid Elastomer [Crowned]	5-5/8"	3-13/16"	HD Roller	600
RT-4200-MR-RB	2"	Multi-Purpose Rubber	5-5/8"	3-13/16"	Roller	450
RT-4200-EL-RB	2"	Eliminator Grey Rubber	5-5/8"	3-13/16"	Roller	600
RT-4200-RMC-RB	2"	Rubber Moldon [H90]	5-5/8"	3-13/16"	Roller	600
RT-4200-NL-RB	2"	Ny-Lite	5-5/8"	3-13/16"	Roller	500

†Wheel diameter: 3-1/4"

## Options

- [1] Use 'RTR' instead of 'RT' when ordering RIGID casters.
- [2] Pedal brake available on swivels and rigids. Add code 'BR' to order number. [example: RT/BR-8200-BST-RB]
- [3] Head seals available on swivels only. Add code 'HS' to order number. [example: RT/HS-4150-NL-RB]
- [4] Delrin bearing. Substitute 'DEL' for 'RB' in order number. [example: RT-4200-MR-DEL]
- [5] Heavy duty roller bearing. Substitute 'HRB' for 'RB' in order number. [example: RT-6200-BST-HRB]
- [6] Flanged ball bearing. Substitute 'FLPBB' for 'RB' in order number. [example: RT-8200-UC-FLPBB]
- [7] Flanged brass bearing. Substitute 'BF' for 'RB' in order number. [example: RT-6200-HT-BF]
- [8] See page 68 for stem options or contact us for custom stems.
- [9] Flanged precision bearing. Substitute 'FLPBB' for 'RB' in order number. [example: RT-5200-UC-FLPBB]

**Note:** Listed capacities are for casters only [without stems]. Some stems may reduce the above listed capacities. Contact us.



# RT/RTR ROUND TOP PLATE SERIES

700 lbs maximum capacity

## RT swivel casters and RTR rigid casters

The RT Series uses the same high quality construction as our signature Bestway series in a stem caster. Our wide selection of standard and custom stems mean that this caster can be mounted in virtually any application. Equipped with 5/8" kingpin construction, 1/4" leg material, 3-1/4" round top plate, zinc plated finish and a large selection of wheel sizes. This is a truly exceptional product. North American made for fast delivery and competitive pricing. Fully customizable upon request. Also available in [stainless steel](#). Use 'RTR' instead of 'RT' in the order number when ordering RIGID casters.



RTR-5200-BAL-RB  
RT STEM: 3/4" x 4" PS

Order number	Tread width	Wheel type	Overall height	Swivel radius	Bearing type	Load cap.
<b>5" Ø wheels</b>						
RT-5150-BAL-RB	1-1/2"	Phenolic	6-1/2"	4-7/16"	Roller	500
RT-5150-BST-RB	1-1/2"	Cast Steel	6-1/2"	4-7/16"	Roller	500
RT-5150-UN-RB	1-1/2"	Star-Tech Urethane	6-1/2"	4-7/16"	Roller	500
RT-5150-UC-RB	1-1/2"	Urethane on Cast	6-1/2"	4-7/16"	Roller	500
RT-5150C-ES-HRB	1-1/2"	Solid Elastomer [Crowned]	6-1/2"	4-7/16"	HD Roller	500
RT-5150-MR-RB	1-1/2"	Multi-Purpose Rubber	6-1/2"	4-7/16"	Roller	450
RT-5150-EL-RB	1-1/2"	Eliminator Grey Rubber	6-1/2"	4-7/16"	Roller	400
RT-5150-RMC-RB	1-1/2"	Rubber Moldon [H90]	6-1/2"	4-7/16"	Roller	500
RT-5150-NL-RB	1-1/2"	Ny-Lite	6-1/2"	4-7/16"	Roller	500
RT-5200-BAL-RB	2"	Phenolic	6-1/2"	4-7/16"	Roller	600
RT-5200-HT-RB	2"	Hi-Temp Phenolic	6-1/2"	4-7/16"	Roller	600
RT-5200-BST-RB	2"	Cast Steel	6-1/2"	4-7/16"	Roller	600
RT-5200-UN-RB	2"	Star-Tech Urethane	6-1/2"	4-7/16"	Roller	600
RT-5200-UC-RB	2"	Urethane on Cast	6-1/2"	4-7/16"	Roller	600
RT-5200C-ES-HRB	2"	Solid Elastomer [Crowned]	6-1/2"	4-7/16"	HD Roller	600
RT-5200-MR-RB	2"	Multi-Purpose Rubber	6-1/2"	4-7/16"	Roller	550
RT-5200-EL-RB	2"	Eliminator Grey Rubber	6-1/2"	4-7/16"	Roller	600
RT-5200-RMC-RB	2"	Rubber Moldon [H90]	6-1/2"	4-7/16"	Roller	600
RT-5200-NL-RB	2"	Ny-Lite	6-1/2"	4-7/16"	Roller	600
<b>6" Ø wheels</b>						
RT-6150-BAL-RB	1-1/2"	Phenolic	7-1/2"	4-9/16"	Roller	500
RT-6150-UN-RB	1-1/2"	Star-Tech Urethane	7-1/2"	4-9/16"	Roller	500
RT-6150-UC-RB	1-1/2"	Urethane on Cast	7-1/2"	4-9/16"	Roller	500
RT-6150-MR-RB	1-1/2"	Multi-Purpose Rubber	7-1/2"	4-9/16"	Roller	500
RT-6150-EL-RB	1-1/2"	Eliminator Grey Rubber	7-1/2"	4-9/16"	Roller	500
RT-6150-RMC-RB	1-1/2"	Rubber Moldon [H90]	7-1/2"	4-9/16"	Roller	500
RT-6150-NL-RB	1-1/2"	Ny-Lite	7-1/2"	4-9/16"	Roller	500
RT-6200-BAL-RB	2"	Phenolic	7-1/2"	4-9/16"	Roller	600
RT-6200-HT-RB	2"	Hi-Temp Phenolic	7-1/2"	4-9/16"	Roller	600
RT-6200-BST-RB	2"	Cast Steel	7-1/2"	4-9/16"	Roller	600
RT-6200-UN-RB	2"	Star-Tech Urethane	7-1/2"	4-9/16"	Roller	600
RT-6200-UC-RB	2"	Urethane on Cast	7-1/2"	4-9/16"	Roller	600
RT-6200-ES-HRB	2"	Solid Elastomer	7-1/2"	4-9/16"	HD Roller	600
RT-6200-ES-PBB	2"	Solid Elastomer	7-1/2"	4-9/16"	Precision Ball	600
RT-6200C-ES-HRB	2"	Solid Elastomer [Crowned]	7-1/2"	4-9/16"	HD Roller	600
RT-6200-MR-RB	2"	Multi-Purpose Rubber	7-1/2"	4-9/16"	Roller	600
RT-6200-EL-RB	2"	Eliminator Grey Rubber	7-1/2"	4-9/16"	Roller	600
RT-6200C-EL-RB	2"	Eliminator Grey Rubber [Crowned]	7-1/2"	4-9/16"	Roller	600
RT-6200-RMC-RB	2"	Rubber Moldon [H90]	7-1/2"	4-9/16"	Roller	600
RT-6200-NL-RB	2"	Ny-Lite	7-1/2"	4-9/16"	Roller	600

# RT/RTR ROUND TOP PLATE SERIES

700 lbs maximum capacity

## RT swivel casters and RTR rigid casters

The RT Series uses the same high quality construction as our signature Bestway series in a stem caster. Our wide selection of standard and custom stems mean that this caster can be mounted in virtually any application. Equipped with 5/8" kingpin construction, 1/4" leg material, 3-1/4" round top plate, zinc plated finish and a large selection of wheel sizes. This is a truly exceptional product. North American made for fast delivery and competitive pricing. Fully customizable upon request. Also available in [stainless steel](#). Use 'RTR' instead of 'RT' in the order number when ordering RIGID casters.



RT-6200-ES-HRB  
RT STEM: 3/4"-10 x 4" TS

Order number	Tread width	Wheel type	Overall height	Swivel radius	Bearing type	Load cap.
<b>8" Ø wheels</b>						
RT-8200-BAL-RB	2"	Phenolic	9-1/2"	5-7/8"	Roller	700
RT-8200-HT-RB	2"	Hi-Temp Phenolic	9-1/2"	5-7/8"	Roller	700
RT-8200-BST-RB	2"	Cast Steel	9-1/2"	5-7/8"	Roller	700
RT-8200-UN-RB	2"	Star-Tech Urethane	9-1/2"	5-7/8"	Roller	700
RT-8200-UC-RB	2"	Urethane on Cast	9-1/2"	5-7/8"	Roller	700
RT-8200-ES-HRB	2"	Solid Elastomer	9-1/2"	5-7/8"	HD Roller	700
RT-8200-ES-PBB	2"	Solid Elastomer	9-1/2"	5-7/8"	Precision Ball	700
RT-8200C-ES-HRB	2"	Solid Elastomer [Crowned]	9-1/2"	5-7/8"	HD Roller	700
RT-8200-MR-RB	2"	Multi-Purpose Rubber	9-1/2"	5-7/8"	Roller	700
RT-8200-EL-RB	2"	Eliminator Grey Rubber	9-1/2"	5-7/8"	Roller	700
RT-8200C-EL-RB	2"	Eliminator Grey Rubber [Crowned]	9-1/2"	5-7/8"	Roller	700
RT-8200-RMC-RB	2"	Rubber Moldon [H90]	9-1/2"	5-7/8"	Roller	700
RT-8200-NL-RB	2"	Ny-Lite	9-1/2"	5-7/8"	Roller	700

# HK/HKR HUSKY SERIES

400 lbs maximum capacity



HK-4150-EL-RB

## HK swivel casters and HKR rigid casters

This husky riveted caster features hardened balls in an extra wide, deep dish single race to provide long life at a reasonable price. Bright zinc plating provides an attractive appearance and added protection for this precision caster. With top plate sizes to match industry standards and a wide range of wheel options, this is the ideal light duty caster for many applications. Use 'HKR' instead of 'HK' in the order number, when ordering RIGID casters.

Order number	Tread width	Wheel type	Plate size	Bolt hole pattern	Bolt size	Overall height	Swivel radius	Bearing type	Load cap.
<b>2" ø wheels</b>									
HK-2-BST	1"	Cast Steel	1-7/8" x 2-9/16"	15/16" x 2-1/8"	1/4"	2-7/16"	1-3/4"	Plain	125
HK-2-UN	7/8"	Star-Tech Urethane	1-7/8" x 2-9/16"	15/16" x 2-1/8"	1/4"	2-7/16"	1-3/4"	Plain	120
HK-2-MR	7/8"	Multi-Purpose Rubber	1-7/8" x 2-9/16"	15/16" x 2-1/8"	1/4"	2-7/16"	1-3/4"	Plain	120
HK-2-NL	3/4"	Ny-Lite	1-7/8" x 2-9/16"	15/16" x 2-1/8"	1/4"	2-7/16"	1-3/4"	Plain	100
HK-2-WNL	3/4"	White Polyolefin	1-7/8" x 2-9/16"	15/16" x 2-1/8"	1/4"	2-7/16"	1-3/4"	Plain	100
<b>2-1/2" ø wheels</b>									
HK-25-BST	1-1/8"	Cast Steel	2-3/4" x 3-7/8"	1-3/4" x 3"	5/16"	3-1/4"	2-3/8"	Plain	225
HK-25-MR	1-1/8"	Multi-Purpose Rubber	2-3/4" x 3-7/8"	1-3/4" x 3"	5/16"	3-1/4"	2-3/8"	Plain	150
HK-25-NL	1"	Ny-Lite	2-3/4" x 3-7/8"	1-3/4" x 3"	5/16"	3-1/4"	2-3/8"	Plain	225
HK-25-NY	1"	White Nylon	2-3/4" x 3-7/8"	1-3/4" x 3"	5/16"	3-1/4"	2-3/8"	Plain	225
<b>3" ø wheels</b>									
HK-3125-BAL	1-1/4"	Phenolic	3-1/8" x 4-1/8"	2-3/8" x 3-3/8" to 3-7/16"	5/16"	3-3/4"	2-7/16"	Plain	300
HK-3125-BST	1-1/4"	Cast Steel	3-1/8" x 4-1/8"	2-3/8" x 3-3/8" to 3-7/16"	5/16"	3-3/4"	2-7/16"	Plain	300
HK-3125C-BST-RB	1-1/4"	Cast Steel [Crowned]	3-1/8" x 4-1/8"	2-3/8" x 3-3/8" to 3-7/16"	5/16"	3-3/4"	2-7/16"	Roller	300
HK-3125-UN-BB	1-1/4"	Star-Tech Urethane	3-1/8" x 4-1/8"	2-3/8" x 3-3/8" to 3-7/16"	5/16"	3-3/4"	2-7/16"	Ball Bearing	250
HK-3125-MR	1-1/4"	Multi-Purpose Rubber	3-1/8" x 4-1/8"	2-3/8" x 3-3/8" to 3-7/16"	5/16"	3-3/4"	2-7/16"	Plain	210
HK-3125-EL-BB	1-1/4"	Eliminator Grey Rubber	3-1/8" x 4-1/8"	2-3/8" x 3-3/8" to 3-7/16"	5/16"	3-3/4"	2-7/16"	Ball Bearing	200
HK-3125-NL	1-1/4"	Ny-Lite	3-1/8" x 4-1/8"	2-3/8" x 3-3/8" to 3-7/16"	5/16"	3-3/4"	2-7/16"	Plain	275
HK-3125-WNL	1-1/4"	White Polyolefin	3-1/8" x 4-1/8"	2-3/8" x 3-3/8" to 3-7/16"	5/16"	3-3/4"	2-7/16"	Plain	275
HK-3150-BAL-RB	1-1/2"	Phenolic	3-1/8" x 4-1/8"	2-3/8" x 3-3/8" to 3-7/16"	5/16"	3-3/4"	2-7/16"	Roller	300
HK-3150-BST-RB	1-1/2"	Cast Steel	3-1/8" x 4-1/8"	2-3/8" x 3-3/8" to 3-7/16"	5/16"	3-3/4"	2-7/16"	Roller	300
HK-3150-VG-RB	1-1/2"	Cast Steel [V-Groove]	3-1/8" x 4-1/8"	2-3/8" x 3-3/8" to 3-7/16"	5/16"	3-3/4"	2-7/16"	Roller	300
HK-3150-UC-RB	1-1/2"	Urethane On Cast	3-1/8" x 4-1/8"	2-3/8" x 3-3/8" to 3-7/16"	5/16"	3-3/4"	2-7/16"	Roller	300
HK-3150C-ES-HRB	1-1/2"	Solid Elastomer [Crowned]	3-1/8" x 4-1/8"	2-3/8" x 3-3/8" to 3-7/16"	5/16"	3-3/4"	2-7/16"	HD Roller	300
HK-3150-NY-RB	1-1/2"	White Nylon	3-1/8" x 4-1/8"	2-3/8" x 3-3/8" to 3-7/16"	5/16"	3-3/4"	2-7/16"	Roller	300
HK-3150C-EAS-PBB	1-1/2"	Anti-Static Elastomer	3-1/8" x 4-1/8"	2-3/8" x 3-3/8" to 3-7/16"	5/16"	3-3/4"	2-7/16"	Precision Ball	300
HK-080-HTM-HL	35mm	Hi-Temp Monolithic	3-1/8" x 4-1/8"	2-3/8" x 3-3/8" to 3-7/16"	5/16"	3-3/4"	2-7/16"	Hi-Lex	220

## Options

- [1] Use 'HKR' instead of 'H' when ordering RIGID casters.
- [2] For side pedal brake on swivels only. Add code 'BR' to order number. [ example: HK/BR-4150-UN-RB ]
- [3] Delrin bearing. Substitute 'DEL' for 'RB' or 'BB' in order number. [ example: HK-3150-NY-DEL ]
- [4] Plate size for RIGID casters:
- |                 |                   |                   |
|-----------------|-------------------|-------------------|
|                 | RIGID plate size  | Bolt hole spacing |
| 2" ø wheels     | 1-1/2" x 2-21/32" | 15/16" x 2-1/8"   |
| 2-1/2" ø wheels | 2-1/4" x 4-7/16"  | 1-1/16" x 3-1/2"  |
| 3" ø wheels     | 2-1/2" x 4-15/16" | 1-3/16" x 4"      |
| 4" ø wheels     | 3-1/8" x 6-1/4"   | 1-3/4" x 5"       |

# HK/HKR HUSKY SERIES

400 lbs maximum capacity

## HK swivel casters and HKR rigid casters

This husky riveted caster features hardened balls in an extra wide, deep dish single race to provide long life at a reasonable price. Bright zinc plating provides an attractive appearance and added protection for this precision caster. With top plate sizes to match industry standards and a wide range of wheel options, this is the ideal light duty caster for many applications. Use 'HKR' instead of 'HK' in the order number, when ordering RIGID casters.



HKR-3125-NL

Order number	Tread width	Wheel type	Plate size	Bolt hole pattern	Bolt size	Overall height	Swivel radius	Bearing type	Load cap.
<b>4" Ø wheels</b>									
HK-4150-BAL-RB	1-1/2"	Phenolic	4" x 5"	3" x 4"	3/8"	5"	3-13/16"	Roller	400
HK-4150-HT-RB	1-1/2"	Hi-Temp Phenolic	4" x 5"	3" x 4"	3/8"	5"	3-13/16"	Roller	400
HK-4150-BST	1-1/2"	Cast Steel	4" x 5"	3" x 4"	3/8"	5"	3-13/16"	Plain	400
HK-4150-BST-RB	1-1/2"	Cast Steel	4" x 5"	3" x 4"	3/8"	5"	3-13/16"	Roller	400
HK-4150-VG-RB	1-1/2"	Cast Steel [V-Groove]	4" x 5"	3" x 4"	3/8"	5"	3-13/16"	Roller	400
HK-4150-UN-RB	1-1/2"	Star-Tech Urethane	4" x 5"	3" x 4"	3/8"	5"	3-13/16"	Roller	400
HK-4150-UC-RB	1-1/2"	Urethane On Cast	4" x 5"	3" x 4"	3/8"	5"	3-13/16"	Roller	400
HK-4150C-ES-HRB	1-1/2"	Solid Elastomer [Crowned]	4" x 5"	3" x 4"	3/8"	5"	3-13/16"	HD Roller	400
HK-4150-MR-RB	1-1/2"	Multi-Purpose Rubber	4" x 5"	3" x 4"	3/8"	5"	3-13/16"	Roller	400
HK-4150-EL-RB	1-1/2"	Eliminator Grey Rubber	4" x 5"	3" x 4"	3/8"	5"	3-13/16"	Roller	350
HK-4150-RMC-RB	1-1/2"	Rubber Moldon [H90]	4" x 5"	3" x 4"	3/8"	5"	3-13/16"	Roller	400
HK-4150-NL-RB	1-1/2"	Ny-Lite	4" x 5"	3" x 4"	3/8"	5"	3-13/16"	Roller	400
HK-4150-NY-RB	1-1/2"	White Nylon	4" x 5"	3" x 4"	3/8"	5"	3-13/16"	Roller	400
HK-4150C-EAS-PBB	1-1/2"	Anti-Static Elastomer	4" x 5"	3" x 4"	3/8"	5"	3-13/16"	Precision Ball	400

# LX/LXR SERIES

250 lbs maximum capacity

## LX swivel casters and LXR rigid casters

This double ball race caster is extremely versatile in many applications, where light loads and easy maneuverability is required. Hardened balls and bright zinc plating assure long life and dependability. Industry standard top plate, slotted to 1-3/4" x 3", large wheel selection, and standard dust cover make this an excellent solution for light duty applications. Also available in [stainless steel](#). Use 'LXR' instead of 'LX' in the order number, when ordering RIGID casters.



LXR-5125-UN-BB

Order number	Tread width	Wheel type	Plate size	Bolt hole pattern*	Bolt size	Overall height	Swivel radius	Bearing type	Load cap.
<b>3" Ø wheels</b>									
LX-3125-BAL	1-1/4"	Phenolic	2-5/8" x 3-3/4"	3" x 3"	5/16"	4-1/8"	2-3/4"	Plain	250
LX-3125-BST	1-1/4"	Cast Steel	2-5/8" x 3-3/4"	3" x 3"	5/16"	4-1/8"	2-3/4"	Plain	250
LX-3125-UN-BB	1-1/4"	Star-Tech Urethane	2-5/8" x 3-3/4"	3" x 3"	5/16"	4-1/8"	2-3/4"	Ball Bearing	250
LX-3125-MR	1-1/4"	Multi-Purpose Rubber	2-5/8" x 3-3/4"	3" x 3"	5/16"	4-1/8"	2-3/4"	Plain	210
LX-3125-EL-BB	1-1/4"	Eliminator Grey Rubber	2-5/8" x 3-3/4"	3" x 3"	5/16"	4-1/8"	2-3/4"	Ball Bearing	200
LX-3125-NL	1-1/4"	Ny-Lite	2-5/8" x 3-3/4"	3" x 3"	5/16"	4-1/8"	2-3/4"	Plain	250
LX-3125-WNL	1-1/4"	White Poly-Olefin	2-5/8" x 3-3/4"	3" x 3"	5/16"	4-1/8"	2-3/4"	Plain	250
LX-3150-BAL-RB	1-1/2"	Phenolic	2-5/8" x 3-3/4"	3" x 3"	5/16"	4-1/8"	2-3/4"	Roller	250
LX-3150-BST-RB	1-1/2"	Cast Steel	2-5/8" x 3-3/4"	3" x 3"	5/16"	4-1/8"	2-3/4"	Roller	250
LX-3150-VG-RB	1-1/2"	Cast Steel [V-Groove]	2-5/8" x 3-3/4"	3" x 3"	5/16"	4-1/8"	2-3/4"	Roller	250
LX-3150-UC-RB	1-1/2"	Urethane on Cast	2-5/8" x 3-3/4"	3" x 3"	5/16"	4-1/8"	2-3/4"	Roller	250
LX-3150C-ES-HRB	1-1/2"	Solid Elastomer [Crowned]	2-5/8" x 3-3/4"	3" x 3"	5/16"	4-1/8"	2-3/4"	HD Roller	250
LX-3150-NY-RB	1-1/2"	White Nylon	2-5/8" x 3-3/4"	3" x 3"	5/16"	4-1/8"	2-3/4"	Roller	250
LX-3150C-EAS-PBB	1-1/2"	Anti-Static Elastomer [Crowned]	2-5/8" x 3-3/4"	3" x 3"	5/16"	4-1/8"	2-3/4"	Precision Ball	250
LX-080-HTM-HL	35mm	Hi-Temp Monolithic	2-5/8" x 3-3/4"	3" x 3"	5/16"	4-1/8"	2-3/4"	Hi-Lex	220
<b>4" Ø wheels</b>									
LX-4125-BAL	1-1/4"	Phenolic	2-5/8" x 3-3/4"	3" x 3"	5/16"	5-1/8"	3-1/4"	Plain	250
LX-4125-BST	1-1/4"	Cast Steel	2-5/8" x 3-3/4"	3" x 3"	5/16"	5-1/8"	3-1/4"	Plain	250
LX-4125-UN-BB	1-1/4"	Star-Tech Urethane	2-5/8" x 3-3/4"	3" x 3"	5/16"	5-1/8"	3-1/4"	Ball Bearing	250
LX-4125-EL-BB	1-1/4"	Eliminator Grey Rubber	2-5/8" x 3-3/4"	3" x 3"	5/16"	5-1/8"	3-1/4"	Ball Bearing	220
LX-4125-NL	1-1/4"	Ny-Lite	2-5/8" x 3-3/4"	3" x 3"	5/16"	5-1/8"	3-1/4"	Plain	250
LX-4125-WNL	1-1/4"	White Poly-Olefin	2-5/8" x 3-3/4"	3" x 3"	5/16"	5-1/8"	3-1/4"	Plain	250
LX-4125-MR	1-1/4"	Multi-Purpose Rubber	2-5/8" x 3-3/4"	3" x 3"	5/16"	5-1/8"	3-1/4"	Plain	250
LX-4150-BAL-RB	1-1/2"	Phenolic	2-5/8" x 3-3/4"	3" x 3"	5/16"	5-1/8"	3-1/4"	Roller	250
LX-4150-HT-RB	1-1/2"	Hi-Temp Phenolic	2-5/8" x 3-3/4"	3" x 3"	5/16"	5-1/8"	3-1/4"	Roller	250
LX-4150-BST	1-1/2"	Cast Steel	2-5/8" x 3-3/4"	3" x 3"	5/16"	5-1/8"	3-1/4"	Plain	250
LX-4150-BST-RB	1-1/2"	Cast Steel	2-5/8" x 3-3/4"	3" x 3"	5/16"	5-1/8"	3-1/4"	Roller	250
LX-4150-VG-RB	1-1/2"	Cast Steel [V-Groove]	2-5/8" x 3-3/4"	3" x 3"	5/16"	5-1/8"	3-1/4"	Roller	250
LX-4150-UN-RB	1-1/2"	Star-Tech Urethane	2-5/8" x 3-3/4"	3" x 3"	5/16"	5-1/8"	3-1/4"	Roller	250
LX-4150-UC-RB	1-1/2"	Urethane on Cast	2-5/8" x 3-3/4"	3" x 3"	5/16"	5-1/8"	3-1/4"	Roller	250
LX-4150C-ES-HRB	1-1/2"	Solid Elastomer [Crowned]	2-5/8" x 3-3/4"	3" x 3"	5/16"	5-1/8"	3-1/4"	HD Roller	250
LX-4150-MR-RB	1-1/2"	Multi-Purpose Rubber	2-5/8" x 3-3/4"	3" x 3"	5/16"	5-1/8"	3-1/4"	Roller	250
LX-4150-EL-RB	1-1/2"	Eliminator Grey Rubber	2-5/8" x 3-3/4"	3" x 3"	5/16"	5-1/8"	3-1/4"	Roller	250
LX-4150-RMC-RB	1-1/2"	Rubber Moldon [H90]	2-5/8" x 3-3/4"	3" x 3"	5/16"	5-1/8"	3-1/4"	Roller	250

## Options

- [1] Use 'LXR' instead of 'LX' when ordering RIGID casters.
- [2] For total lock brake on swivels only. Add code 'TLB' to order number. [example: LX/TLB-5150-UC-RB]
- [3] Delrin bearing. Substitute 'DEL' for 'RB' or 'BB' in order number. [example: LXR-3150-NY-DEL]
- [4] \*Bolt hole pattern is slotted to 1-3/4" x 3".

# LX/LXR SERIES

250 lbs maximum capacity

## LX swivel casters and LXR rigid casters

This double ball race caster is extremely versatile in many applications, where light loads and easy maneuverability is required. Hardened balls and bright zinc plating assure long life and dependability. Industry standard top plate, slotted to 1-3/4" x 3", large wheel selection, and standard dust cover make this an excellent solution for light duty applications. Also available in [stainless steel](#). Use 'LXR' instead of 'LX' in the order number, when ordering RIGID casters.



LX/TLB-5125-UN-BB

Order number	Tread width	Wheel type	Plate size	Bolt hole pattern*	Bolt size	Overall height	Swivel radius	Bearing type	Load cap.
LX-4150-NL-RB	1-1/2"	Ny-Lite	2-5/8" x 3-3/4"	3" x 3"	5/16"	5-1/8"	3-1/4"	Roller	250
LX-4150-NY-RB	1-1/2"	White Nylon	2-5/8" x 3-3/4"	3" x 3"	5/16"	5-1/8"	3-1/4"	Roller	250
LX-4150C-EAS-PBB	1-1/2"	Anti-Static Elastomer [Crowned]	2-5/8" x 3-3/4"	3" x 3"	5/16"	5-1/8"	3-1/4"	Precision Ball	250
LX-100-HTM-HL	35mm	Hi-Temp Monolithic	2-5/8" x 3-3/4"	3" x 3"	5/16"	5-1/8"	3-1/4"	Hi-Lex	250
<b>5" Ø wheels</b>									
LX-5125-BAL	1-1/4"	Phenolic	2-5/8" x 3-3/4"	3" x 3"	5/16"	6-1/8"	3-3/4"	Plain	250
LX-5125-UN-BB	1-1/4"	Star-Tech Urethane	2-5/8" x 3-3/4"	3" x 3"	5/16"	6-1/8"	3-3/4"	Ball Bearing	250
LX-5125-EL-BB	1-1/4"	Eliminator Grey Rubber	2-5/8" x 3-3/4"	3" x 3"	5/16"	6-1/8"	3-3/4"	Ball Bearing	250
LX-5125-NL	1-1/4"	Ny-Lite	2-5/8" x 3-3/4"	3" x 3"	5/16"	6-1/8"	3-3/4"	Plain	250
LX-5125-WNL	1-1/4"	White Poly-Olefin	2-5/8" x 3-3/4"	3" x 3"	5/16"	6-1/8"	3-3/4"	Plain	250
LX-5150-BAL-RB	1-1/2"	Phenolic	2-5/8" x 3-3/4"	3" x 3"	5/16"	6-1/8"	3-3/4"	Roller	250
LX-5150-BST-RB	1-1/2"	Cast Steel	2-5/8" x 3-3/4"	3" x 3"	5/16"	6-1/8"	3-3/4"	Roller	250
LX-5150-UN-RB	1-1/2"	Star-Tech Urethane	2-5/8" x 3-3/4"	3" x 3"	5/16"	6-1/8"	3-3/4"	Roller	250
LX-5150-UC-RB	1-1/2"	Urethane on Cast	2-5/8" x 3-3/4"	3" x 3"	5/16"	6-1/8"	3-3/4"	Roller	250
LX-5150C-ES-HRB	1-1/2"	Solid Elastomer [Crowned]	2-5/8" x 3-3/4"	3" x 3"	5/16"	6-1/8"	3-3/4"	HD Roller	250
LX-5150-MR-RB	1-1/2"	Multi-Purpose Rubber	2-5/8" x 3-3/4"	3" x 3"	5/16"	6-1/8"	3-3/4"	Roller	250
LX-5150-EL-RB	1-1/2"	Eliminator Grey Rubber	2-5/8" x 3-3/4"	3" x 3"	5/16"	6-1/8"	3-3/4"	Roller	250
LX-5150-RMC-RB	1-1/2"	Rubber Moldon [H90]	2-5/8" x 3-3/4"	3" x 3"	5/16"	6-1/8"	3-3/4"	Roller	250
LX-5150-NL-RB	1-1/2"	Ny-Lite	2-5/8" x 3-3/4"	3" x 3"	5/16"	6-1/8"	3-3/4"	Roller	250
LX-5150-NY-RB	1-1/2"	White Nylon	2-5/8" x 3-3/4"	3" x 3"	5/16"	6-1/8"	3-3/4"	Roller	250
LX-5150C-EAS-PBB	1-1/2"	Anti-Static Elastomer [Crowned]	2-5/8" x 3-3/4"	3" x 3"	5/16"	6-1/8"	3-3/4"	Precision Ball	250

# GP/GPR GENERAL PURPOSE SERIES

600 lbs maximum capacity

## GP swivel and GPR rigid casters

This medium duty caster offers a wide range of benefits and options, including a total lock, and a [stainless steel](#) version. The swivel version has a precision formed double ball raceways and standard head seals. The total lock brake locks both, wheel and swivel simultaneously with one press of the pedal. Simply kick the pedal to release. Top plate dimensions match European standards and slotted mounting holes to 2-5/8" x 3-3/8". Use 'GPR' instead of 'GP' in the order number, when ordering RIGID casters.



GP-4150-EL-RB

Order number	Tread width	Wheel type	Plate size	Bolt hole pattern*	Bolt size	Overall height	Swivel radius	Bearing type	Load cap.
<b>3" Ø wheels</b>									
GP-3125-BAL	1-1/4"	Phenolic	3-3/8" x 4-1/8"	2-1/8" x 2-7/8"	5/16"	4-1/4"	3"	Plain	300
GP-3125-BST	1-1/4"	Cast Steel	3-3/8" x 4-1/8"	2-1/8" x 2-7/8"	5/16"	4-1/4"	3"	Plain	300
GP-3125-UN-BB	1-1/4"	Star-Tech Urethane	3-3/8" x 4-1/8"	2-1/8" x 2-7/8"	5/16"	4-1/4"	3"	Ball Bearing	250
GP-3125-MR	1-1/4"	Multi-Purpose Rubber	3-3/8" x 4-1/8"	2-1/8" x 2-7/8"	5/16"	4-1/4"	3"	Plain	210
GP-3125-EL-BB	1-1/4"	Eliminator Grey Rubber	3-3/8" x 4-1/8"	2-1/8" x 2-7/8"	5/16"	4-1/4"	3"	Ball Bearing	200
GP-3125-NL	1-1/4"	Ny-Lite	3-3/8" x 4-1/8"	2-1/8" x 2-7/8"	5/16"	4-1/4"	3"	Plain	275
GP-3125-WNL	1-1/4"	White Poly-Olefin	3-3/8" x 4-1/8"	2-1/8" x 2-7/8"	5/16"	4-1/4"	3"	Plain	275
GP-3150-BAL-RB	1-1/2"	Phenolic	3-3/8" x 4-1/8"	2-1/8" x 2-7/8"	5/16"	4-1/4"	3"	Roller	300
GP-3150-BST-RB	1-1/2"	Cast Steel	3-3/8" x 4-1/8"	2-1/8" x 2-7/8"	5/16"	4-1/4"	3"	Roller	300
GP-3150-VG-RB	1-1/2"	Cast Steel [V-Groove]	3-3/8" x 4-1/8"	2-1/8" x 2-7/8"	5/16"	4-1/4"	3"	Roller	300
GP-3150-UC-RB	1-1/2"	Urethane on Cast	3-3/8" x 4-1/8"	2-1/8" x 2-7/8"	5/16"	4-1/4"	3"	Roller	300
GP-3150C-ES-HRB	1-1/2"	Solid Elastomer [Crowned]	3-3/8" x 4-1/8"	2-1/8" x 2-7/8"	5/16"	4-1/4"	3"	HD Roller	300
GP-3150-NY-RB	1-1/2"	White Nylon	3-3/8" x 4-1/8"	2-1/8" x 2-7/8"	5/16"	4-1/4"	3"	Roller	300
GP-3150C-EAS-HRB	1-1/2"	Anti-Static Elastomer	3-3/8" x 4-1/8"	2-1/8" x 2-7/8"	5/16"	4-1/4"	3"	HD Roller	300
GP-080-HTM-HL	35mm	Hi-Temp Monolithic	3-3/8" x 4-1/8"	2-1/8" x 2-7/8"	5/16"	4-1/4"	3"	Hi-Lex	220
<b>4" Ø wheels</b>									
GP-4125-BAL	1-1/4"	Phenolic	3-3/8" x 4-1/8"	2-1/8" x 2-7/8"	5/16"	5-1/16"	3-1/2"	Plain	300
GP-4125-BST	1-1/4"	Cast Steel	3-3/8" x 4-1/8"	2-1/8" x 2-7/8"	5/16"	5-1/16"	3-1/2"	Plain	400
GP-4125-UN-BB	1-1/4"	Star-Tech Urethane	3-3/8" x 4-1/8"	2-1/8" x 2-7/8"	5/16"	5-1/16"	3-1/2"	Ball Bearing	250
GP-4125-EL-BB	1-1/4"	Eliminator Grey Rubber	3-3/8" x 4-1/8"	2-1/8" x 2-7/8"	5/16"	5-1/16"	3-1/2"	Ball Bearing	220
GP-4125-NL	1-1/4"	Ny-Lite	3-3/8" x 4-1/8"	2-1/8" x 2-7/8"	5/16"	5-1/16"	3-1/2"	Plain	300
GP-4125-WNL	1-1/4"	White Poly-Olefin	3-3/8" x 4-1/8"	2-1/8" x 2-7/8"	5/16"	5-1/16"	3-1/2"	Plain	300
GP-4125-MR	1-1/4"	Multi-Purpose Rubber	3-3/8" x 4-1/8"	2-1/8" x 2-7/8"	5/16"	5-1/16"	3-1/2"	Plain	300
GP-4150-BAL-RB	1-1/2"	Phenolic	3-3/8" x 4-1/8"	2-1/8" x 2-7/8"	5/16"	5-1/16"	3-1/2"	Roller	400
GP-4150-HT-RB	1-1/2"	Hi-Temp Phenolic	3-3/8" x 4-1/8"	2-1/8" x 2-7/8"	5/16"	5-1/16"	3-1/2"	Roller	400
GP-4150-BST	1-1/2"	Cast Steel	3-3/8" x 4-1/8"	2-1/8" x 2-7/8"	5/16"	5-1/16"	3-1/2"	Plain	400
GP-4150-BST-RB	1-1/2"	Cast Steel	3-3/8" x 4-1/8"	2-1/8" x 2-7/8"	5/16"	5-1/16"	3-1/2"	Roller	400
GP-4150-VG-RB	1-1/2"	Cast Steel [V-Groove]	3-3/8" x 4-1/8"	2-1/8" x 2-7/8"	5/16"	5-1/16"	3-1/2"	Roller	400
GP-4150-UN-RB	1-1/2"	Star-Tech Urethane	3-3/8" x 4-1/8"	2-1/8" x 2-7/8"	5/16"	5-1/16"	3-1/2"	Roller	400
GP-4150-UC-RB	1-1/2"	Urethane on Cast	3-3/8" x 4-1/8"	2-1/8" x 2-7/8"	5/16"	5-1/16"	3-1/2"	Roller	400
GP-4150C-ES-HRB	1-1/2"	Solid Elastomer [Crowned]	3-3/8" x 4-1/8"	2-1/8" x 2-7/8"	5/16"	5-1/16"	3-1/2"	HD Roller	400
GP-4150-MR-RB	1-1/2"	Multi-Purpose Rubber	3-3/8" x 4-1/8"	2-1/8" x 2-7/8"	5/16"	5-1/16"	3-1/2"	Roller	400
GP-4150-EL-RB	1-1/2"	Eliminator Grey Rubber	3-3/8" x 4-1/8"	2-1/8" x 2-7/8"	5/16"	5-1/16"	3-1/2"	Roller	350
GP-4150-RMC-RB	1-1/2"	Rubber Moldon [H90]	3-3/8" x 4-1/8"	2-1/8" x 2-7/8"	5/16"	5-1/16"	3-1/2"	Roller	400

## Options

- [1] Use 'GPR' instead of 'GP' when ordering RIGID casters.
- [2] Total Lock Brake available for swivel casters only. Add 'TLB' to the order number. [ example: GP/TLB-5150-EL-RB ]
- [3] Delrin bearing. Substitute 'DEL' for 'RB' or 'BB' in order number. [ example: GP-3150-BAL-DEL ]
- [4] Optional 4" x 4-1/2" top plate available. Add code 'STP' to order number. [ example: GP/STP-6150-BAL-RB ]
- [5] \*Bolt hole pattern is slotted to 2-5/8" x 3-3/8".

# GP/GPR GENERAL PURPOSE SERIES

600 lbs maximum capacity

## GP swivel and GPR rigid casters

This medium duty caster offers a wide range of benefits and options, including a total lock, and a [stainless steel](#) version. The swivel version has a precision formed double ball raceways and standard head seals. The total lock brake locks both, wheel and swivel simultaneously with one press of the pedal. Simply kick the pedal to release. Top plate dimensions match European standards and slotted mounting holes to 2-5/8" x 3-3/8". Use 'GPR' instead of 'GP' in the order number, when ordering RIGID casters.



GPR-4150-NY-RB

Order number	Tread width	Wheel type	Plate size	Bolt hole pattern*	Bolt size	Overall height	Swivel radius	Bearing type	Load cap.
GP-4150-NL-RB	1-1/2"	Ny-Lite	3-3/8" x 4-1/8"	2-1/8" x 2-7/8"	5/16"	5-1/16"	3-1/2"	Roller	400
GP-4150-NY-RB	1-1/2"	White Nylon	3-3/8" x 4-1/8"	2-1/8" x 2-7/8"	5/16"	5-1/16"	3-1/2"	Roller	400
GP-4150C-EAS-HRB	1-1/2"	Anti-Static Elastomer	3-3/8" x 4-1/8"	2-1/8" x 2-7/8"	5/16"	5-1/16"	3-1/2"	HD Roller	400
GP-100-HTM-HL	35mm	Hi-Temp Monolithic	3-3/8" x 4-1/8"	2-1/8" x 2-7/8"	5/16"	5-1/16"	3-1/2"	Hi-Lex	275
<b>5" Ø wheels</b>									
GP-5150-BAL-RB	1-1/2"	Phenolic	3-3/8" x 4-1/8"	2-1/8" x 2-7/8"	5/16"	6-1/8"	4-1/4"	Roller	450
GP-5150-BST-RB	1-1/2"	Cast Steel	3-3/8" x 4-1/8"	2-1/8" x 2-7/8"	5/16"	6-1/8"	4-1/4"	Roller	450
GP-5150-UN-RB	1-1/2"	Star-Tech Urethane	3-3/8" x 4-1/8"	2-1/8" x 2-7/8"	5/16"	6-1/8"	4-1/4"	Roller	450
GP-5150-UC-RB	1-1/2"	Urethane on Cas	3-3/8" x 4-1/8"	2-1/8" x 2-7/8"	5/16"	6-1/8"	4-1/4"	Roller	450
GP-5150C-ES-HRB	1-1/2"	Solid Elastomer [Crowned]	3-3/8" x 4-1/8"	2-1/8" x 2-7/8"	5/16"	6-1/8"	4-1/4"	HD Roller	450
GP-5150-MR-RB	1-1/2"	Multi-Purpose Rubber	3-3/8" x 4-1/8"	2-1/8" x 2-7/8"	5/16"	6-1/8"	4-1/4"	Roller	450
GP-5150-EL-RB	1-1/2"	Eliminator Grey Rubber	3-3/8" x 4-1/8"	2-1/8" x 2-7/8"	5/16"	6-1/8"	4-1/4"	Roller	400
GP-5150-RMC-RB	1-1/2"	Rubber Moldon [H90]	3-3/8" x 4-1/8"	2-1/8" x 2-7/8"	5/16"	6-1/8"	4-1/4"	Roller	450
GP-5150-NL-RB	1-1/2"	Ny-Lite	3-3/8" x 4-1/8"	2-1/8" x 2-7/8"	5/16"	6-1/8"	4-1/4"	Roller	450
GP-5150-NY-RB	1-1/2"	White Nylon	3-3/8" x 4-1/8"	2-1/8" x 2-7/8"	5/16"	6-1/8"	4-1/4"	Roller	450
GP-5150C-EAS-HRB	1-1/2"	Anti-Static Elastomer	3-3/8" x 4-1/8"	2-1/8" x 2-7/8"	5/16"	6-1/8"	4-1/4"	HD Roller	450
GP-125-HTM-HL	40mm	Hi-Temp Monolithic	3-3/8" x 4-1/8"	2-1/8" x 2-7/8"	5/16"	6-1/8"	4-1/4"	Hi-Lex	330
<b>6" Ø wheels</b>									
GP-6150-BAL-RB	1-1/2"	Phenolic	3-3/8" x 4-1/8"	2-1/8" x 2-7/8"	5/16"	7-1/8"	4-3/4"	Roller	600
GP-6150-UN-RB	1-1/2"	Star-Tech Urethane	3-3/8" x 4-1/8"	2-1/8" x 2-7/8"	5/16"	7-1/8"	4-3/4"	Roller	600
GP-6150-UC-RB	1-1/2"	Urethane on Cast	3-3/8" x 4-1/8"	2-1/8" x 2-7/8"	5/16"	7-1/8"	4-3/4"	Roller	600
GP-6150-MR-RB	1-1/2"	Multi-Purpose Rubber	3-3/8" x 4-1/8"	2-1/8" x 2-7/8"	5/16"	7-1/8"	4-3/4"	Roller	550
GP-6150-EL-RB	1-1/2"	Eliminator Grey Rubber	3-3/8" x 4-1/8"	2-1/8" x 2-7/8"	5/16"	7-1/8"	4-3/4"	Roller	500
GP-6150-RMC-RB	1-1/2"	Rubber Moldon [H90]	3-3/8" x 4-1/8"	2-1/8" x 2-7/8"	5/16"	7-1/8"	4-3/4"	Roller	600
GP-6150-NL-RB	1-1/2"	Ny-Lite	3-3/8" x 4-1/8"	2-1/8" x 2-7/8"	5/16"	7-1/8"	4-3/4"	Roller	600
GP-6150-NY-RB	1-1/2"	White Nylon	3-3/8" x 4-1/8"	2-1/8" x 2-7/8"	5/16"	7-1/8"	4-3/4"	Roller	600



# BW/BWR BESTWAY SERIES

1,000 lbs maximum capacity

## BW swivel casters and BWR rigid casters

Our signature Bestway 'BW' and 'BWR' caster series is the best solution available in the 600 lbs to 1,000 lbs load capacity range. Top quality North American construction. This quiet caster is designed for easy swiveling and can take the abuse in rough conditions and continuous use. Our superior 5/8" nut and bolt kingpin construction with precision double ball raceways prove much more durable than riveted models. Heavy 1/4" material provides maximum strength and long life. Zinc plated housings with greased fitting in the swivel head for easy maintenance. Plate has 2-5/8" x 3-5/8" or 3" x 3" slotted mounting holes, as listed, for flexible mounting. Quick delivery, customizable. Ideal for industrial applications, warehouses, institutions, department stores, and other heavy duty equipment and machines. Also available in [stainless steel](#). Use 'BWR' instead of 'BW' in the order number, when ordering RIGID casters.



BW/BR-5150-BAL-RB

Order number	Tread width	Wheel type	Plate size	Bolt hole pattern*	Bolt size	Overall height	Swivel radius	Bearing type	Load cap.
<b>3" Ø wheels</b>									
BW-3150-BAL-RB	1-1/2"	Phenolic	4" x 4-1/2"	3" x 3"	3/8"	4-3/8"	2-3/4"	Roller	500
BW-3150-BST-RB	1-1/2"	Cast Steel	4" x 4-1/2"	3" x 3"	3/8"	4-3/8"	2-3/4"	Roller	500
BW-3150-VG-RB	1-1/2"	Cast Steel [V-Groove]	4" x 4-1/2"	3" x 3"	3/8"	4-3/8"	2-3/4"	Roller	350
BW-3150-UC-RB	1-1/2"	Urethane on Cast	4" x 4-1/2"	3" x 3"	3/8"	4-3/8"	2-3/4"	Roller	400
BW-3150C-ES-HRB	1-1/2"	Solid Elastomer [Crowned]	4" x 4-1/2"	3" x 3"	3/8"	4-3/8"	2-3/4"	HD Roller	350
BW-3150-RMC-RB	1-1/2"	Rubber Moldon [H90]	4" x 4-1/2"	3" x 3"	3/8"	4-3/8"	2-3/4"	Roller	300
BW-3150-NY-RB	1-1/2"	White Nylon	4" x 4-1/2"	3" x 3"	3/8"	4-3/8"	2-3/4"	Roller	500
BW-3200-BAL-RB†	2"	Phenolic	4" x 4-1/2"	3" x 3"	3/8"	4-1/2"	2-13/16"	Roller	700
BW-3200-BST-RB	2"	Cast Steel	4" x 4-1/2"	3" x 3"	3/8"	4-3/8"	2-3/4"	Roller	700
BW-3200-UC-RB	2"	Urethane on Cast	4" x 4-1/2"	3" x 3"	3/8"	4-3/8"	2-3/4"	Roller	540
BW-3200-NL-RB	2"	Ny-Lite	4" x 4-1/2"	3" x 3"	3/8"	4-3/8"	2-3/4"	Roller	400
BW-3200-NY-RB	2"	White Nylon	4" x 4-1/2"	3" x 3"	3/8"	4-3/8"	2-3/4"	Roller	700
<b>4" Ø wheels</b>									
BW-4150-BAL-RB	1-1/2"	Phenolic	4" x 4-1/2"	3" x 3"	3/8"	5-5/8"	3-13/16"	Roller	600
BW-4150-HT-RB	1-1/2"	Hi-Temp Phenolic	4" x 4-1/2"	3" x 3"	3/8"	5-5/8"	3-13/16"	Roller	400
BW-4150-BST	1-1/2"	Cast Steel	4" x 4-1/2"	3" x 3"	3/8"	5-5/8"	3-13/16"	Plain	600
BW-4150-BST-RB	1-1/2"	Cast Steel	4" x 4-1/2"	3" x 3"	3/8"	5-5/8"	3-13/16"	Roller	600
BW-4150-VG-RB	1-1/2"	Cast Steel [V-Groove]	4" x 4-1/2"	3" x 3"	3/8"	5-5/8"	3-13/16"	Roller	500
BW-4150-UN-RB	1-1/2"	Star-Tech Urethane	4" x 4-1/2"	3" x 3"	3/8"	5-5/8"	3-13/16"	Roller	440
BW-4150-UC-RB	1-1/2"	Urethane on Cast	4" x 4-1/2"	3" x 3"	3/8"	5-5/8"	3-13/16"	Roller	600
BW-4150C-ES-HRB	1-1/2"	Solid Elastomer [Crowned]	4" x 4-1/2"	3" x 3"	3/8"	5-5/8"	3-13/16"	HD Roller	400
BW-4150-MR-RB	1-1/2"	Multi-Purpose Rubber	4" x 4-1/2"	3" x 3"	3/8"	5-5/8"	3-13/16"	Roller	400
BW-4150-EL-RB	1-1/2"	Eliminator Grey Rubber	4" x 4-1/2"	3" x 3"	3/8"	5-5/8"	3-13/16"	Roller	350
BW-4150-RMC-RB	1-1/2"	Rubber Moldon [H90]	4" x 4-1/2"	3" x 3"	3/8"	5-5/8"	3-13/16"	Roller	500
BW-4150-NL-RB	1-1/2"	Ny-Lite	4" x 4-1/2"	3" x 3"	3/8"	5-5/8"	3-13/16"	Roller	420
BW-4150-NY-RB	1-1/2"	White Nylon	4" x 4-1/2"	3" x 3"	3/8"	5-5/8"	3-13/16"	Roller	600
BW-4200-BAL-RB	2"	Phenolic	4" x 4-1/2"	3" x 3"	3/8"	5-5/8"	3-13/16"	Roller	800
BW-4200-LAM-RB	2"	Laminated Phenolic	4" x 4-1/2"	3" x 3"	3/8"	5-5/8"	3-13/16"	Roller	900
BW-4200-HT-RB	2"	Hi-Temp Phenolic	4" x 4-1/2"	3" x 3"	3/8"	5-5/8"	3-13/16"	Roller	500

† Wheel diameter: 3-1/4"

## Options

- [1] Use 'BWR' instead of 'BW' when ordering RIGID casters.
- [2] Rigid casters also available with V-Groove wheels.
- [3] Total Lock Brake available only for the swivel version with the 4" x 4-1/2" top plate. Add 'TLB' to the order number [ example: BW/TLB-8200-BAL-RB ]. total lock brake is not available for 3" versions.
- [4] 4-position swivel lock. Add code '4SL' to the order number [ example: BW/4SL-5200-EL-RB ]. Special order with ISO, K5 and PFI plates.
- [5] Optional top plate sizes available. Add code 'LTP', 'BTP', 'ISO', 'K5' or 'PFI' to the order number. [ example: BWR/LTP-5200-BAL-RB ]
- [6] Head seals available on swivel casters only. Add code 'HS' to the order number. [ example: BW/HS-4150-NL-RB ]
- [7] Delrin bearing. Substitute 'DEL' for 'RB' in the order number. [ example: BW-4200-MR-DEL ]
- [8] Heavy duty roller bearing. Substitute 'HRB' for 'RB' in the order number. [ example: BW-6200C-DU-HRB ]
- [9] Flanged precision bearing. Substitute 'FLPBB' for 'RB' in the order number. [ example: BW-8200-UC-FLPBB ]
- [10] † Flanged brass bearing. Substitute 'BF' for 'RB' in the order number. [ example: BW-6200-HT-BF ]
- [11] Pedal brake available on swivels and rigid versions. Add code 'BR' to order number. [ example: BW/BR-8200-BST-BR ]
- [12] \*Bolt hole pattern is slotted to 2-5/8" x 3-5/8" or 3" x 3", as listed.

# BW/BWR BESTWAY SERIES

1,000 lbs maximum capacity

## BW swivel casters and BWR rigid casters

Our signature Bestway 'BW' and 'BWR' caster series is the best solution available in the 600 lbs to 1,000 lbs load capacity range. Top quality North American construction. This quiet caster is designed for easy swiveling and can take the abuse in rough conditions and continuous use. Our superior 5/8" nut and bolt kingpin construction with precision double ball raceways prove much more durable than riveted models. Heavy 1/4" material provides maximum strength and long life. Zinc plated housings with grease fitting in the swivel head for easy maintenance. Plate has 2-5/8" x 3-5/8" or 3" x 3" slotted mounting holes, as listed, for flexible mounting. Quick delivery, customizable. Ideal for industrial applications, warehouses, institutions, department stores, and other heavy duty equipment and machines. Also available in [stainless steel](#). Use 'BWR' instead of 'BW' in the order number, when ordering RIGID casters.



BW/TLB-6200-BAL-RB

Order number	Tread width	Wheel type	Plate size	Bolt hole pattern*	Bolt size	Overall height	Swivel radius	Bearing type	Load cap.
BW-4200-BST-RB	2"	Cast Steel	4" x 4-1/2"	3" x 3"	3/8"	5-5/8"	3-13/16"	Roller	800
BW-4200-VG-RB	2"	Cast Steel [V-Groove]	4" x 4-1/2"	3" x 3"	3/8"	5-5/8"	3-13/16"	Roller	800
BW-4200C-DU-RB	2"	Ductile Iron [Crowned]	4" x 4-1/2"	3" x 3"	3/8"	5-5/8"	3-13/16"	Roller	900
BW-4200-VGD-RB	2"	Ductile Iron [V-Groove]	4" x 4-1/2"	3" x 3"	3/8"	5-5/8"	3-13/16"	Roller	900
BW-4200-FLD-RB	2"	Ductile Iron [Flanged]	4" x 4-1/2"	3" x 3"	3/8"	5-5/8"	3-13/16"	Roller	900
BW-4200-UN-RB	2"	Star-Tech Urethane	4" x 4-1/2"	3" x 3"	3/8"	5-5/8"	3-13/16"	Roller	600
BW-4200-UC-RB	2"	Urethane on Cast	4" x 4-1/2"	3" x 3"	3/8"	5-5/8"	3-13/16"	Roller	700
BW-4200C-UC-RB	2"	Urethane on Cast [Crowned]	4" x 4-1/2"	3" x 3"	3/8"	5-5/8"	3-13/16"	Roller	800
BW-4200C-UBA-PBB	2"	Urethane on Alum. [Crowned]	4" x 4-1/2"	3" x 3"	3/8"	5-5/8"	3-13/16"	Precision Ball	900
BW-4200C-MBA-PBB	2"	Megabest [Crowned]	4" x 4-1/2"	3" x 3"	3/8"	5-5/8"	3-13/16"	Precision Ball	300
BW-4200C-ES-HRB	2"	Solid Elastomer [Crowned]	4" x 4-1/2"	3" x 3"	3/8"	5-5/8"	3-13/16"	HD Roller	800
BW-4200C-ES-PBB	2"	Solid Elastomer [Crowned]	4" x 4-1/2"	3" x 3"	3/8"	5-5/8"	3-13/16"	Precision Ball	800
BW-4200-MR-RB	2"	Multi-Purpose Rubber	4" x 4-1/2"	3" x 3"	3/8"	5-5/8"	3-13/16"	Roller	450
BW-4200-EL-RB	2"	Eliminator Grey Rubber	4" x 4-1/2"	3" x 3"	3/8"	5-5/8"	3-13/16"	Roller	600
BW-4200-RMC-RB	2"	Rubber Moldon [H90]	4" x 4-1/2"	3" x 3"	3/8"	5-5/8"	3-13/16"	Roller	700
BW-4200-NL-RB	2"	Ny-Lite	4" x 4-1/2"	3" x 3"	3/8"	5-5/8"	3-13/16"	Roller	500
BW-4200-NY-RB	2"	White Nylon	4" x 4-1/2"	3" x 3"	3/8"	5-5/8"	3-13/16"	Roller	800
<b>5" ø wheels</b>									
BW-5150-BAL-RB	1-1/2"	Phenolic	4" x 4-1/2"	3" x 3"	3/8"	6-1/2"	4-7/16"	Roller	600
BW-5150-BST-RB	1-1/2"	Cast Steel	4" x 4-1/2"	3" x 3"	3/8"	6-1/2"	4-7/16"	Roller	650
BW-5150-UN-RB	1-1/2"	Star-Tech Urethane	4" x 4-1/2"	3" x 3"	3/8"	6-1/2"	4-7/16"	Roller	500
BW-5150-UC-RB	1-1/2"	Urethane on Cast	4" x 4-1/2"	3" x 3"	3/8"	6-1/2"	4-7/16"	Roller	650
BW-5150C-ES-HRB	1-1/2"	Solid Elastomer [Crowned]	4" x 4-1/2"	3" x 3"	3/8"	6-1/2"	4-7/16"	HD Roller	500
BW-5150-MR-RB	1-1/2"	Multi-Purpose Rubber	4" x 4-1/2"	3" x 3"	3/8"	6-1/2"	4-7/16"	Roller	450
BW-5150-EL-RB	1-1/2"	Eliminator Grey Rubber	4" x 4-1/2"	3" x 3"	3/8"	6-1/2"	4-7/16"	Roller	400
BW-5150-RMC-RB	1-1/2"	Rubber Moldon [H90]	4" x 4-1/2"	3" x 3"	3/8"	6-1/2"	4-7/16"	Roller	600
BW-5150-NL-RB	1-1/2"	Ny-Lite	4" x 4-1/2"	3" x 3"	3/8"	6-1/2"	4-7/16"	Roller	550
BW-5150-NY-RB	1-1/2"	White Nylon	4" x 4-1/2"	3" x 3"	3/8"	6-1/2"	4-7/16"	Roller	600
BW-5200-BAL-RB	2"	Phenolic	4" x 4-1/2"	3" x 3"	3/8"	6-1/2"	4-7/16"	Roller	900
BW-5200-LAM-RB	2"	Laminated Phenolic	4" x 4-1/2"	3" x 3"	3/8"	6-1/2"	4-7/16"	Roller	900
BW-5200-HT-RB	2"	Hi-Temp Phenolic	4" x 4-1/2"	3" x 3"	3/8"	6-1/2"	4-7/16"	Roller	750
BW-5200-BST-RB	2"	Cast Steel	4" x 4-1/2"	3" x 3"	3/8"	6-1/2"	4-7/16"	Roller	825
Contact Us	2"	Cast Steel [V-Groove]	4" x 4-1/2"	3" x 3"	3/8"	6-1/2"	4-7/16"	Roller	800
BW-5200C-DU-RB	2"	Ductile Iron [Crowned]	4" x 4-1/2"	3" x 3"	3/8"	6-1/2"	4-7/16"	Roller	900
Contact Us	2"	Ductile Iron [V-Groove]	4" x 4-1/2"	3" x 3"	3/8"	6-1/2"	4-7/16"	Roller	900
Contact Us	2"	Ductile Iron [Flanged]	4" x 4-1/2"	3" x 3"	3/8"	6-1/2"	4-7/16"	Roller	900
BW-5200-UN-RB	2"	Star-Tech Urethane	4" x 4-1/2"	3" x 3"	3/8"	6-1/2"	4-7/16"	Roller	750
BW-5200-UC-RB	2"	Urethane on Cast	4" x 4-1/2"	3" x 3"	3/8"	6-1/2"	4-7/16"	Roller	900
BW-5200C-UC-RB	2"	Urethane on Cast [Crowned]	4" x 4-1/2"	3" x 3"	3/8"	6-1/2"	4-7/16"	Roller	900
BW-5200C-UBA-PBB	2"	Urethane on Alum. [Crowned]	4" x 4-1/2"	3" x 3"	3/8"	6-1/2"	4-7/16"	Precision Ball	900
BW-5200C-MBA-PBB	2"	Megabest [Crowned]	4" x 4-1/2"	3" x 3"	3/8"	6-1/2"	4-7/16"	Precision Ball	300

# BW/BWR BESTWAY SERIES

1,000 lbs maximum capacity

## BW swivel casters and BWR rigid casters

Our signature Bestway 'BW' and 'BWR' caster series is the best solution available in the 600 lbs to 1,000 lbs load capacity range. Top quality North American construction. This quiet caster is designed for easy swiveling and can take the abuse in rough conditions and continuous use. Our superior 5/8" nut and bolt kingpin construction with precision double ball raceways prove much more durable than riveted models. Heavy 1/4" material provides maximum strength and long life. Zinc plated housings with grease fitting in the swivel head for easy maintenance. Plate has 2-5/8" x 3-5/8" or 3" x 3" slotted mounting holes, as listed, for flexible mounting. Quick delivery, customizable. Ideal for industrial applications, warehouses, institutions, department stores, and other heavy duty equipment and machines. Also available in [stainless steel](#). Use 'BWR' instead of 'BW' in the order number, when ordering RIGID casters.



BW-6200-PNAF-RB

Order number	Tread width	Wheel type	Plate size	Bolt hole pattern*	Bolt size	Overall height	Swivel radius	Bearing type	Load cap.
BW-5200C-ES-HRB	2"	Solid Elastomer [Crowned]	4" x 4-1/2"	3" x 3"	3/8"	6-1/2"	4-7/16"	HD Roller	900
BW-5200C-ES-PBB	2"	Solid Elastomer [Crowned]	4" x 4-1/2"	3" x 3"	3/8"	6-1/2"	4-7/16"	Precision Ball	900
BW-5200-MR-RB	2"	Multi-Purpose Rubber	4" x 4-1/2"	3" x 3"	3/8"	6-1/2"	4-7/16"	Roller	550
BW-5200-EL-RB	2"	Eliminator Grey Rubber	4" x 4-1/2"	3" x 3"	3/8"	6-1/2"	4-7/16"	Roller	700
BW-5200-RMC-RB	2"	Rubber Moldon [H90]	4" x 4-1/2"	3" x 3"	3/8"	6-1/2"	4-7/16"	Roller	800
BW-5200-NL-RB	2"	Ny-Lite	4" x 4-1/2"	3" x 3"	3/8"	6-1/2"	4-7/16"	Roller	650
BW-5200-NY-RB	2"	White Nylon	4" x 4-1/2"	3" x 3"	3/8"	6-1/2"	4-7/16"	Roller	900
<b>6" Ø wheels</b>									
BW-6150-BAL-RB	1-1/2"	Phenolic	4" x 4-1/2"	3" x 3"	3/8"	7-1/2"	4-9/16"	Roller	700
BW-6150-UN-RB	1-1/2"	Star-Tech Urethane	4" x 4-1/2"	3" x 3"	3/8"	7-1/2"	4-9/16"	Roller	600
BW-6150-UC-RB	1-1/2"	Urethane on Cast	4" x 4-1/2"	3" x 3"	3/8"	7-1/2"	4-9/16"	Roller	700
BW-6150-MR-RB	1-1/2"	Multi-Purpose Rubber	4" x 4-1/2"	3" x 3"	3/8"	7-1/2"	4-9/16"	Roller	550
BW-6150-EL-RB	1-1/2"	Eliminator Grey Rubber	4" x 4-1/2"	3" x 3"	3/8"	7-1/2"	4-9/16"	Roller	500
BW-6150-RMC-RB	1-1/2"	Rubber Moldon [H90]	4" x 4-1/2"	3" x 3"	3/8"	7-1/2"	4-9/16"	Roller	620
BW-6150-NL-RB	1-1/2"	Ny-Lite	4" x 4-1/2"	3" x 3"	3/8"	7-1/2"	4-9/16"	Roller	600
BW-6150-NY-RB	1-1/2"	White Nylon	4" x 4-1/2"	3" x 3"	3/8"	7-1/2"	4-9/16"	Roller	700
BW-6200-BAL-RB	2"	Phenolic	4" x 4-1/2"	3" x 3"	3/8"	7-1/2"	4-9/16"	Roller	900
BW-6200-LAM-RB	2"	Laminated Phenolic	4" x 4-1/2"	3" x 3"	3/8"	7-1/2"	4-9/16"	Roller	900
BW-6200-HT-RB	2"	Hi-Temp Phenolic	4" x 4-1/2"	3" x 3"	3/8"	7-1/2"	4-9/16"	Roller	900
BW-6200-BST-RB	2"	Cast Steel	4" x 4-1/2"	3" x 3"	3/8"	7-1/2"	4-9/16"	Roller	900
BW-6200-VG-RB	2"	Cast Steel [V-Groove]	4" x 4-1/2"	3" x 3"	3/8"	7-1/2"	4-9/16"	Roller	900
BW-6200C-DU-RB	2"	Ductile Iron [Crowned]	4" x 4-1/2"	3" x 3"	3/8"	7-1/2"	4-9/16"	Roller	900
BW-6200-VGD-RB	2"	Ductile Iron [V-Groove]	4" x 4-1/2"	3" x 3"	3/8"	7-1/2"	4-9/16"	Roller	900
BW-6200-FLD-RB	2"	Ductile Iron [Flanged]	4" x 4-1/2"	3" x 3"	3/8"	7-1/2"	4-9/16"	Roller	900
BW-6200-UN-RB	2"	Star-Tech Urethane	4" x 4-1/2"	3" x 3"	3/8"	7-1/2"	4-9/16"	Roller	900
BW-6200-UC-RB	2"	Urethane on Cast	4" x 4-1/2"	3" x 3"	3/8"	7-1/2"	4-9/16"	Roller	900
BW-6200C-UC-RB	2"	Urethane on Cast [Crowned]	4" x 4-1/2"	3" x 3"	3/8"	7-1/2"	4-9/16"	Roller	900
BW-6200C-UBA-PBB	2"	Urethane on Alum. [Crowned]	4" x 4-1/2"	3" x 3"	3/8"	7-1/2"	4-9/16"	Precision Ball	900
BW-6200C-MBA-PBB	2"	Megabest [Crowned]	4" x 4-1/2"	3" x 3"	3/8"	7-1/2"	4-9/16"	Precision Ball	400
BW-6200-ES-HRB	2"	Solid Elastomer	4" x 4-1/2"	3" x 3"	3/8"	7-1/2"	4-9/16"	HD Roller	900
BW-6200-ES-PBB	2"	Solid Elastomer	4" x 4-1/2"	3" x 3"	3/8"	7-1/2"	4-9/16"	Precision Ball	900
BW-6200C-ES-HRB	2"	Solid Elastomer [Crowned]	4" x 4-1/2"	3" x 3"	3/8"	7-1/2"	4-9/16"	HD Roller	900
BW-6200C-ES-PBB	2"	Solid Elastomer [Crowned]	4" x 4-1/2"	3" x 3"	3/8"	7-1/2"	4-9/16"	Precision Ball	900
BW-6200C-EG-PBB	2"	Elastiglide [Crowned]	4" x 4-1/2"	3" x 3"	3/8"	7-1/2"	4-9/16"	Precision Ball	900
BW-6200-MR-RB	2"	Multi-Purpose Rubber	4" x 4-1/2"	3" x 3"	3/8"	7-1/2"	4-9/16"	Roller	650
BW-6200-EL-RB	2"	Eliminator Grey Rubber	4" x 4-1/2"	3" x 3"	3/8"	7-1/2"	4-9/16"	Roller	900
BW-6200C-EL-RB	2"	Eliminator Grey Rubber [Crowned]	4" x 4-1/2"	3" x 3"	3/8"	7-1/2"	4-9/16"	Roller	900
BW-6200-RMC-RB	2"	Rubber Moldon [H90]	4" x 4-1/2"	3" x 3"	3/8"	7-1/2"	4-9/16"	Roller	900
BW-6200-NL-RB	2"	Ny-Lite	4" x 4-1/2"	3" x 3"	3/8"	7-1/2"	4-9/16"	Roller	800
BW-6200-NY-RB	2"	White Nylon	4" x 4-1/2"	3" x 3"	3/8"	7-1/2"	4-9/16"	Roller	900
BW-6200-PN-RB	2"	Full Pneumatic	4" x 4-1/2"	3" x 3"	3/8"	7-1/2"	4-9/16"	Roller	300

# BW/BWR BESTWAY SERIES

1,000 lbs maximum capacity

## BW swivel casters and BWR rigid casters

Our signature Bestway 'BW' and 'BWR' caster series is the best solution available in the 600 lbs to 1,000 lbs load capacity range. Top quality North American construction. This quiet caster is designed for easy swiveling and can take the abuse in rough conditions and continuous use. Our superior 5/8" nut and bolt kingpin construction with precision double ball raceways prove much more durable than riveted models. Heavy 1/4" material provides maximum strength and long life. Zinc plated housings with grease fitting in the swivel head for easy maintenance. Plate has 2-5/8" x 3-5/8" or 3" x 3" slotted mounting holes, as listed, for flexible mounting. Quick delivery, customizable. Ideal for industrial applications, warehouses, institutions, department stores, and other heavy duty equipment and machines. Also available in [stainless steel](#). Use 'BWR' instead of 'BW' in the order number, when ordering RIGID casters.

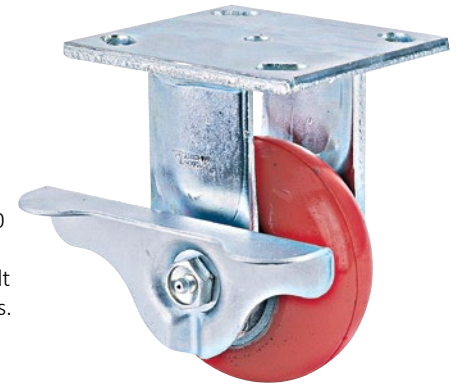

BWR/BR-4200C-UC-RB

Order number	Tread width	Wheel type	Plate size	Bolt hole pattern*	Bolt size	Overall height	Swivel radius	Bearing type	Load cap.
<b>8" ø wheels</b>									
BW-8200-BAL-RB	2"	Phenolic	4" x 4-1/2"	3" x 3"	3/8"	9-1/2"	5-7/8"	Roller	1,000
BW-8200-LAM-RB	2"	Laminated Phenolic	4" x 4-1/2"	3" x 3"	3/8"	9-1/2"	5-7/8"	Roller	1,000
BW-8200-HT-RB	2"	Hi-Temp Phenolic	4" x 4-1/2"	3" x 3"	3/8"	9-1/2"	5-7/8"	Roller	1,000
BW-8200-BST-RB	2"	Cast Steel	4" x 4-1/2"	3" x 3"	3/8"	9-1/2"	5-7/8"	Roller	1,000
BW-8200C-DU-RB	2"	Ductile Iron [Crowned]	4" x 4-1/2"	3" x 3"	3/8"	9-1/2"	5-7/8"	Roller	1,000
BW-8200-VG-RB	2"	Ductile Iron [V-Groove]	4" x 4-1/2"	3" x 3"	3/8"	9-1/2"	5-7/8"	Roller	1,000
BW-8200-FLD-RB	2"	Ductile Iron [Flanged]	4" x 4-1/2"	3" x 3"	3/8"	9-1/2"	5-7/8"	Roller	1,000
BW-8200-UN-RB	2"	Star-Tech Urethane	4" x 4-1/2"	3" x 3"	3/8"	9-1/2"	5-7/8"	Roller	1,000
BW-8200-UC-RB	2"	Urethane on Cast	4" x 4-1/2"	3" x 3"	3/8"	9-1/2"	5-7/8"	Roller	1,000
BW-8200C-UC-RB	2"	Urethane on Cast [Crowned]	4" x 4-1/2"	3" x 3"	3/8"	9-1/2"	5-7/8"	Roller	1,000
BW-8200C-UBA-PBB	2"	Urethane on Alum. [Crowned]	4" x 4-1/2"	3" x 3"	3/8"	9-1/2"	5-7/8"	Precision Ball	1,000
BW-8200C-MBA-PBB	2"	Megabest [Crowned]	4" x 4-1/2"	3" x 3"	3/8"	9-1/2"	5-7/8"	Precision Ball	500
BW-8200-ES-HRB	2"	Solid Elastomer	4" x 4-1/2"	3" x 3"	3/8"	9-1/2"	5-7/8"	HD Roller	1,000
BW-8200-ES-PBB	2"	Solid Elastomer	4" x 4-1/2"	3" x 3"	3/8"	9-1/2"	5-7/8"	Precision Ball	1,000
BW-8200C-ES-HRB	2"	Solid Elastomer [Crowned]	4" x 4-1/2"	3" x 3"	3/8"	9-1/2"	5-7/8"	HD Roller	1,000
BW-8200C-ES-PBB	2"	Solid Elastomer [Crowned]	4" x 4-1/2"	3" x 3"	3/8"	9-1/2"	5-7/8"	Precision Ball	1,000
BW-8200C-EG-PBB	2"	Elastiglide [Crowned]	4" x 4-1/2"	3" x 3"	3/8"	9-1/2"	5-7/8"	Precision Ball	1,000
BW-8200-MR-RB	2"	Multi-Purpose Rubber	4" x 4-1/2"	3" x 3"	3/8"	9-1/2"	5-7/8"	Roller	700
BW-8200-EL-RB	2"	Eliminator Grey Rubber	4" x 4-1/2"	3" x 3"	3/8"	9-1/2"	5-7/8"	Roller	900
BW-8200C-EL-RB	2"	Eliminator Grey Rubber [Crowned]	4" x 4-1/2"	3" x 3"	3/8"	9-1/2"	5-7/8"	Roller	900
BW-8200-RMC-RB	2"	Rubber Moldon [H90]	4" x 4-1/2"	3" x 3"	3/8"	9-1/2"	5-7/8"	Roller	1,000
BW-8200-NL-RB	2"	Ny-Lite	4" x 4-1/2"	3" x 3"	3/8"	9-1/2"	5-7/8"	Roller	1,000
BW-8200-NY-RB	2"	White Nylon	4" x 4-1/2"	3" x 3"	3/8"	9-1/2"	5-7/8"	Roller	1,000

# BESTWAY'S DOUBLE BALL KINGBOLTLESS CASTERS

Bestway has revolutionized the Caster Industry, with the introduction of our patented double ball kingboltless casters! Traditional caster designs feature a rivet or kingpin to hold together the raceways of a swivel caster. While this design may be fine for many applications, rough usage, shockload, or towline applications can place tremendous force on the kingpin causing it to bend. Once this happens, the caster will fail to swivel properly and the raceway may open up allowing the ball bearings to escape or the kingpin may even break.

Bestway has overcome this problem with the invention of our revolutionary double ball kingboltless casters. These swivels feature a pair of precision-machined raceways, welded directly to the mounting plate. The entire assembly is locked together by a double row of hardened ball bearings. Unlike inferior single race models, this design allows one raceway to handle the load and the second race to take the swivel action, making the caster much easier to operate. Most importantly, there is no kingpin to bend or break. The resulting caster is not only much stronger than traditional designs, but also lasts longer under even the most extreme conditions.

By using only Bestway patented double ball kingboltless casters you can rest assured that you are dealing with the industry leader in caster design innovation. Bestway is your guarantee of quality since all of our patented double ball kingboltless casters are North American made, ensuring the highest quality construction, and quick delivery. Our casters are fully customizable.

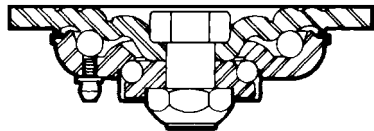

Cross-section of traditional caster designs

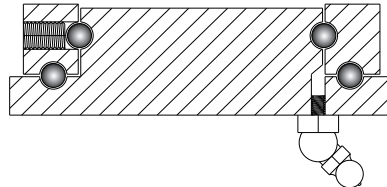

Cross-section of patented double ball kingboltless design

# LD/LDR KINGBOLTLESS SERIES

1,500 lbs maximum capacity

## LD swivel casters and LDR rigid casters

This revolutionary caster uses Bestway's patented double ball kingboltless design to eliminate the need for rivets or kingbolts, a common cause of caster failures. With a higher capacity than traditional kingpin designs, and engineered to withstand punishing towline and shockload applications, which would destroy most ordinary casters, the LD Series is a truly exceptional product. North American made for fast delivery, and competitive pricing. Fully customizable upon request. The LD swivel uses 3-1/2" diameter precision machined and hardened raceways incorporating over sixty 1/4" diameter ball bearings in two raceways, securely welded to a 1/4" top plate. Plate has 2-5/8" x 3-5/8" or 3" x 3" slotted mounting holes, as listed, for flexible mounting. Legs are welded inside and out. The caster is zinc plated for a lasting finish and fitted with a threaded 45° angle grease fitting for easy maintenance. Also available in [stainless steel](#). Use 'LDR' instead of 'LD' in the order number, when ordering RIGID casters.



LD-6200C-DU-RB

Order number	Tread width	Wheel type	Plate size	Bolt hole pattern*	Bolt size	Overall height	Swivel radius	Bearing type	Load cap.
<b>3" Ø wheels</b>									
LD-3200-BST-RB	2"	Cast Steel	4" x 4-1/2"	3" x 3"	3/8"	4-1/2"	2-1/2"	Roller	700
LD-3200-UC-RB	2"	Urethane on Cast	4" x 4-1/2"	3" x 3"	3/8"	4-1/2"	2-1/2"	Roller	540
LD-3200-BAL-RB†	2"	Phenolic	4" x 4-1/2"	3" x 3"	3/8"	4-5/8"	2-5/8"	Roller	700
LD-3200-SEZ-PBB	2"	Swivel-Eaz Urethane on Alum.	4" x 4-1/2"	3" x 3"	3/8"	4-1/2"	2-1/2"	Precision Ball	800
<b>4" Ø wheels</b>									
LD-4200-BAL-RB	2"	Phenolic	4" x 4-1/2"	3" x 3"	3/8"	5-5/8"	3-1/4"	Roller	800
LD-4200-LAM-RB	2"	Laminated Phenolic	4" x 4-1/2"	3" x 3"	3/8"	5-5/8"	3-1/4"	Roller	1,200
LD-4200-HT-RB	2"	Hi-Temp Phenolic	4" x 4-1/2"	3" x 3"	3/8"	5-5/8"	3-1/4"	Roller	500
LD-4200-BST-RB	2"	Cast Steel	4" x 4-1/2"	3" x 3"	3/8"	5-5/8"	3-1/4"	Roller	800
LD-4200-VG-RB	2"	Cast Steel [V-Groove]	4" x 4-1/2"	3" x 3"	3/8"	5-5/8"	3-1/4"	Roller	800
LD-4200C-DU-RB	2"	Ductile Iron [Crowned]	4" x 4-1/2"	3" x 3"	3/8"	5-5/8"	3-1/4"	Roller	1,500
LD-4200-VGD-RB	2"	Ductile Iron [V-Groove]	4" x 4-1/2"	3" x 3"	3/8"	5-5/8"	3-1/4"	Roller	1,500
LD-4200C-FLD-RB	2"	Ductile Iron [Flanged]	4" x 4-1/2"	3" x 3"	3/8"	5-5/8"	3-1/4"	Roller	1,500
LD-4200-MS-RB	2"	Machined Steel	4" x 4-1/2"	3" x 3"	3/8"	5-5/8"	3-1/4"	Roller	1,500
LD-4200-UN-RB	2"	Star-Tech Urethane	4" x 4-1/2"	3" x 3"	3/8"	5-5/8"	3-1/4"	Roller	600
LD-4200-UC-RB	2"	Urethane on Cast	4" x 4-1/2"	3" x 3"	3/8"	5-5/8"	3-1/4"	Roller	700
LD-4200C-UC-RB	2"	Urethane on Cast [Crowned]	4" x 4-1/2"	3" x 3"	3/8"	5-5/8"	3-1/4"	Roller	700
LD-4200C-UBA-PBB	2"	Urethane on Alum. [Crowned]	4" x 4-1/2"	3" x 3"	3/8"	5-5/8"	3-1/4"	Precision Ball	900
LD-4200C-MBA-PBB	2"	Megabest [Crowned]	4" x 4-1/2"	3" x 3"	3/8"	5-5/8"	3-1/4"	Precision Ball	300
LD-4200C-ES-PBB	2"	Solid Elastomer [Crowned]	4" x 4-1/2"	3" x 3"	3/8"	5-5/8"	3-1/4"	Precision Ball	800
LD-4200-EL-RB	2"	Eliminator Grey Rubber	4" x 4-1/2"	3" x 3"	3/8"	5-5/8"	3-1/4"	Roller	600
LD-4200-RMC-RB	2"	Rubber Moldon [H90]	4" x 4-1/2"	3" x 3"	3/8"	5-5/8"	3-1/4"	Roller	700
LD-4200-SEZ-PBB	2"	Swivel-Eaz Urethane on Alum.	4" x 4-1/2"	3" x 3"	3/8"	5-5/8"	3-1/4"	Precision Ball	900

† Wheel diameter: 3-1/4"

## Options

- [1] Use 'LDR' instead of 'LD' when ordering RIGID casters.
- [2] Pedal brake available on swivels and rigids. Add code 'BR' to order number. [ example: LD/BR-8200-BST-RB ]
- [3] Four Position Swivel Lock. Add code '4SL' to order number. [ example: LD/4SL-5200-EL-RB ]. Special order with ISO, K5 and PFI Plates.
- [4] Optional top plates available. Add code LTP, BTP, ISO, K5 or PFI to order number. [ example: LDR/LTP-5200-BAL-RB ]
- [5] Head seals available on swivels only. Add code 'HS' to order number. [ example: LD/HS-4200-NL-RB ]
- [6] Heavy duty roller bearing. Substitute 'HRB' for 'RB' in order number. [ example: LD-6200C-DU-HRB ]
- [7] Flanged brass bearing. Substitute 'BF' for 'RB' in order number. [ example: LD-6200-HT-BF ]
- [8] Flanged precision bearing. Substitute 'FLPBB' for 'RB' in order number. [ example: LD-8200-UC-FLPBB ]
- [9] \*Bolt hole pattern is slotted to 2-5/8" x 3-5/8" or 3" x 3".

# LD/LDR KINGBOLTLESS SERIES

1,500 lbs maximum capacity

## LD swivel casters and LDR rigid casters

This revolutionary caster uses Bestway's patented double ball kingboltless design to eliminate the need for rivets or kingbolts, a common cause of caster failures. With a higher capacity than traditional kingpin designs, and engineered to withstand punishing towline and shockload applications, which would destroy most ordinary casters, the LD Series is a truly exceptional product. North American made for fast delivery, and competitive pricing. Fully customizable upon request. The LD swivel uses 3-1/2" diameter precision machined and hardened raceways incorporating over sixty 1/4" diameter ball bearings in two raceways, securely welded to a 1/4" top plate. Plate has 2-5/8" x 3-5/8" or 3" x 3" slotted mounting holes, as listed, for flexible mounting. Legs are welded inside and out. The caster is zinc plated for a lasting finish and fitted with a threaded 45° angle grease fitting for easy maintenance. Also available in [stainless steel](#). Use 'LDR' instead of 'LD' in the order number, when ordering RIGID casters.



LD-6200C-DU-RB

Order number	Tread width	Wheel type	Plate size	Bolt hole pattern*	Bolt size	Overall height	Swivel radius	Bearing type	Load cap.
<b>5" Ø wheels</b>									
LD-5200-BAL-RB	2"	Phenolic	4" x 4-1/2"	3" x 3"	3/8"	6-1/2"	4"	Roller	1,000
LD-5200-LAM-RB	2"	Laminated Phenolic	4" x 4-1/2"	3" x 3"	3/8"	6-1/2"	4"	Roller	1,400
LD-5200-HT-RB	2"	Hi-Temp Phenolic	4" x 4-1/2"	3" x 3"	3/8"	6-1/2"	4"	Roller	750
LD-5200-BST-RB	2"	Cast Steel	4" x 4-1/2"	3" x 3"	3/8"	6-1/2"	4"	Roller	825
LD-5200-VG-RB	2"	Cast Steel [V-Groove]	4" x 4-1/2"	3" x 3"	3/8"	6-1/2"	4"	Roller	800
LD-5200C-DU-RB	2"	Ductile Iron [Crowned]	4" x 4-1/2"	3" x 3"	3/8"	6-1/2"	4"	Roller	1,500
LD-5200-VGD-RB	2"	Ductile Iron [V-Groove]	4" x 4-1/2"	3" x 3"	3/8"	6-1/2"	4"	Roller	1,500
LD-5200-FLD-RB	2"	Ductile Iron [Flanged]	4" x 4-1/2"	3" x 3"	3/8"	6-1/2"	4"	Roller	1,500
LD-5200-MS-RB	2"	Machined Steel	4" x 4-1/2"	3" x 3"	3/8"	6-1/2"	4"	Roller	1,500
LD-5200-UN-RB	2"	Star-Tech Urethane	4" x 4-1/2"	3" x 3"	3/8"	6-1/2"	4"	Roller	750
LD-5200-UC-RB	2"	Urethane on Cast	4" x 4-1/2"	3" x 3"	3/8"	6-1/2"	4"	Roller	1,050
LD-5200C-UC-RB	2"	Urethane on Cast [Crowned]	4" x 4-1/2"	3" x 3"	3/8"	6-1/2"	4"	Roller	1,000
LD-5200C-UBA-PBB	2"	Urethane on Alum. [Crowned]	4" x 4-1/2"	3" x 3"	3/8"	6-1/2"	4"	Precision Ball	900
LD-5200C-MBA-PBB	2"	Megabest [Crowned]	4" x 4-1/2"	3" x 3"	3/8"	6-1/2"	4"	Precision Ball	300
LD-5200C-ES-PBB	2"	Solid Elastomer [Crowned]	4" x 4-1/2"	3" x 3"	3/8"	6-1/2"	4"	Precision Ball	1,000
LD-5200-EL-RB	2"	Eliminator Grey Rubber	4" x 4-1/2"	3" x 3"	3/8"	6-1/2"	4"	Roller	700
LD-5200-RMC-RB	2"	Rubber Moldon [H90]	4" x 4-1/2"	3" x 3"	3/8"	6-1/2"	4"	Roller	800
<b>6" Ø wheels</b>									
LD-6200-BAL-RB	2"	Phenolic	4" x 4-1/2"	3" x 3"	3/8"	7-1/2"	4-1/4"	Roller	1,200
LD-6200-LAM-RB	2"	Laminated Phenolic	4" x 4-1/2"	3" x 3"	3/8"	7-1/2"	4-1/4"	Roller	1,500
LD-6200-HT-RB	2"	Hi-Temp Phenolic	4" x 4-1/2"	3" x 3"	3/8"	7-1/2"	4-1/4"	Roller	900
LD-6200-BST-RB	2"	Cast Steel	4" x 4-1/2"	3" x 3"	3/8"	7-1/2"	4-1/4"	Roller	1,000
LD-6200-VG-RB	2"	Cast Steel [V-Groove]	4" x 4-1/2"	3" x 3"	3/8"	7-1/2"	4-1/4"	Roller	1,000
LD-6200C-DU-RB	2"	Ductile Iron [Crowned]	4" x 4-1/2"	3" x 3"	3/8"	7-1/2"	4-1/4"	Roller	1,500
LD-6200-VGD-RB	2"	Ductile Iron [V-Groove]	4" x 4-1/2"	3" x 3"	3/8"	7-1/2"	4-1/4"	Roller	1,500
LD-6200-FLD-RB	2"	Ductile Iron [Flanged]	4" x 4-1/2"	3" x 3"	3/8"	7-1/2"	4-1/4"	Roller	1,500
LD-6200-MS-RB	2"	Machined Steel	4" x 4-1/2"	3" x 3"	3/8"	7-1/2"	4-1/4"	Roller	1,500
LD-6200-UN-RB	2"	Star-Tech Urethane	4" x 4-1/2"	3" x 3"	3/8"	7-1/2"	4-1/4"	Roller	900
LD-6200-UC-RB	2"	Urethane on Cast	4" x 4-1/2"	3" x 3"	3/8"	7-1/2"	4-1/4"	Roller	1,230
LD-6200C-UC-RB	2"	Urethane on Cast [Crowned]	4" x 4-1/2"	3" x 3"	3/8"	7-1/2"	4-1/4"	Roller	1,050
LD-6200C-UBA-PBB	2"	Urethane on Alum. [Crowned]	4" x 4-1/2"	3" x 3"	3/8"	7-1/2"	4-1/4"	Precision Ball	1,200
LD-6200C-MBA-PBB	2"	Megabest [Crowned]	4" x 4-1/2"	3" x 3"	3/8"	7-1/2"	4-1/4"	Precision Ball	400
LD-6200-ES-PBB	2"	Solid Elastomer	4" x 4-1/2"	3" x 3"	3/8"	7-1/2"	4-1/4"	Precision Ball	1,200
LD-6200C-ES-PBB	2"	Solid Elastomer [Crowned]	4" x 4-1/2"	3" x 3"	3/8"	7-1/2"	4-1/4"	Precision Ball	1,200
LD-6200C-EG-PBB	2"	Elastiglide [Crowned]	4" x 4-1/2"	3" x 3"	3/8"	7-1/2"	4-1/4"	Precision Ball	1,200
LD-6200-EL-RB	2"	Eliminator Grey Rubber	4" x 4-1/2"	3" x 3"	3/8"	7-1/2"	4-1/4"	Roller	900
LD-6200C-EL-RB	2"	Eliminator Grey Rubber [Crowned]	4" x 4-1/2"	3" x 3"	3/8"	7-1/2"	4-1/4"	Roller	900
LD-6200-RMC-RB	2"	Rubber Moldon [H90]	4" x 4-1/2"	3" x 3"	3/8"	7-1/2"	4-1/4"	Roller	900
LD-6200-SEZ-PBB	2"	Swivel-Eaz Urethane on Alum.	4" x 4-1/2"	3" x 3"	3/8"	7-1/2"	4-1/4"	Precision Ball	1,500

# LD/LDR KINGBOLTLESS SERIES

1,500 lbs maximum capacity

## LD swivel casters and LDR rigid casters

This revolutionary caster uses Bestway's patented double ball kingboltless design to eliminate the need for rivets or kingbolts, a common cause of caster failures. With a higher capacity than traditional kingpin designs, and engineered to withstand punishing towline and shockload applications, which would destroy most ordinary casters, the LD Series is a truly exceptional product. North American made for fast delivery, and competitive pricing. Fully customizable upon request. The LD swivel uses 3-1/2" diameter precision machined and hardened raceways incorporating over sixty 1/4" diameter ball bearings in two raceways, securely welded to a 1/4" top plate. Plate has 2-5/8" x 3-5/8" or 3" x 3" slotted mounting holes, as listed, for flexible mounting. Legs are welded inside and out. The caster is zinc plated for a lasting finish and fitted with a threaded 45° angle grease fitting for easy maintenance. Also available in [stainless steel](#). Use 'LDR' instead of 'LD' in the order number, when ordering RIGID casters.



LDR-6200C-UC-RB

Order number	Tread width	Wheel type	Plate size	Bolt hole pattern*	Bolt size	Overall height	Swivel radius	Bearing type	Load cap.
<b>8" ø wheels</b>									
LD-8200-BAL-RB	2"	Phenolic	4" x 4-1/2"	3" x 3"	3/8"	9-1/2"	5-5/8"	Roller	1,400
LD-8200-LAM-RB	2"	Laminated Phenolic	4" x 4-1/2"	3" x 3"	3/8"	9-1/2"	5-5/8"	Roller	1,500
LD-8200-HT-RB	2"	Hi-Temp Phenolic	4" x 4-1/2"	3" x 3"	3/8"	9-1/2"	5-5/8"	Roller	1,100
LD-8200-BST-RB	2"	Cast Steel	4" x 4-1/2"	3" x 3"	3/8"	9-1/2"	5-5/8"	Roller	1,200
LD-8200C-DU-RB	2"	Ductile Iron [Crowned]	4" x 4-1/2"	3" x 3"	3/8"	9-1/2"	5-5/8"	Roller	1,500
LD-8200-VGD-RB	2"	Ductile Iron [V-Groove]	4" x 4-1/2"	3" x 3"	3/8"	9-1/2"	5-5/8"	Roller	1,500
LD-8200-FLD-RB	2"	Ductile Iron [Flanged]	4" x 4-1/2"	3" x 3"	3/8"	9-1/2"	5-5/8"	Roller	1,500
LD-8200-UN-RB	2"	Star-Tech Urethane	4" x 4-1/2"	3" x 3"	3/8"	9-1/2"	5-5/8"	Roller	1,000
LD-8200-UC-RB	2"	Urethane on Cast	4" x 4-1/2"	3" x 3"	3/8"	9-1/2"	5-5/8"	Roller	1,500
LD-8200C-UC-RB	2"	Urethane on Cast [Crowned]	4" x 4-1/2"	3" x 3"	3/8"	9-1/2"	5-5/8"	Roller	1,250
LD-8200C-UBA-PBB	2"	Urethane on Alum. [Crowned]	4" x 4-1/2"	3" x 3"	3/8"	9-1/2"	5-5/8"	Precision Ball	1,500
LD-8200C-MBA-PBB	2"	Megabest [Crowned]	4" x 4-1/2"	3" x 3"	3/8"	9-1/2"	5-5/8"	Precision Ball	500
LD-8200-ES-PBB	2"	Solid Elastomer	4" x 4-1/2"	3" x 3"	3/8"	9-1/2"	5-5/8"	Precision Ball	1,500
LD-8200C-ES-PBB	2"	Solid Elastomer [Crowned]	4" x 4-1/2"	3" x 3"	3/8"	9-1/2"	5-5/8"	Precision Ball	1,500
LD-8200C-EG-PBB	2"	Elastiglide [Crowned]	4" x 4-1/2"	3" x 3"	3/8"	9-1/2"	5-5/8"	Precision Ball	1,500
LD-8200-EL-RB	2"	Eliminator Grey Rubber	4" x 4-1/2"	3" x 3"	3/8"	9-1/2"	5-5/8"	Roller	900
LD-8200C-EL-RB	2"	Eliminator Grey Rubber [Crowned]	4" x 4-1/2"	3" x 3"	3/8"	9-1/2"	5-5/8"	Roller	900
LD-8200-RMC-RB	2"	Rubber Moldon [H90]	4" x 4-1/2"	3" x 3"	3/8"	9-1/2"	5-5/8"	Roller	1,000
LD-8200-SEZ-PBB	2"	Swivel-Eaz Urethane on Alum.	4" x 4-1/2"	3" x 3"	3/8"	9-1/2"	5-5/8"	Precision Ball	1,500



# HD/HDR SERIES

## 1,200 lbs maximum capacity



HD/4SL-6200-UC-RB

### HD swivel casters and HDR rigid casters

This is a heavier duty version of our proven Bestway series casters. It's improved features include; a high-capacity 3/4" nut and bolt kingpin, larger upper and lower ball races featuring 3/8" and 5/16" diameter hardened ball bearings respectively, a larger [ 4-1/2" x 6-1/4" ] industry standard top plate, and reinforced legs on both swivels and rigids. Plate has 3-3/8" x 5-1/4" slotted mounting holes for flexible mounting. The zinc plate finish and a grease fitting in the swivel head, this caster is ideal for higher capacity applications. North American made for fast delivery and competitive pricing. Fully customizable upon request. Also available in [stainless steel](#). Use 'HDR' instead of 'HD' in the order number, when ordering RIGID casters.

Order number	Tread width	Wheel type	Plate size	Bolt hole pattern*	Bolt size	Overall height	Swivel radius	Bearing type	Load cap.
<b>4" Ø wheels</b>									
HD-4200-BAL-RB	2"	Phenolic	4-1/2" x 6-1/4"	2-7/16" x 4-15/16"	1/2"	5-5/8"	3-5/16"	Roller	800
HD-4200-LAM-RB	2"	Laminated Phenolic	4-1/2" x 6-1/4"	2-7/16" x 4-15/16"	1/2"	5-5/8"	3-5/16"	Roller	1,000
HD-4200-HT-RB	2"	Hi-Temp Phenolic	4-1/2" x 6-1/4"	2-7/16" x 4-15/16"	1/2"	5-5/8"	3-5/16"	Roller	500
HD-4200-BST-RB	2"	Cast Steel	4-1/2" x 6-1/4"	2-7/16" x 4-15/16"	1/2"	5-5/8"	3-5/16"	Roller	800
HD-4200-VG-RB	2"	Cast Steel [V-Groove]	4-1/2" x 6-1/4"	2-7/16" x 4-15/16"	1/2"	5-5/8"	3-5/16"	Roller	800
HD-4200C-DU-RB	2"	Ductile Iron [Crowned]	4-1/2" x 6-1/4"	2-7/16" x 4-15/16"	1/2"	5-5/8"	3-5/16"	Roller	1,000
HD-4200-VGD-RB	2"	Ductile Iron [V-Groove]	4-1/2" x 6-1/4"	2-7/16" x 4-15/16"	1/2"	5-5/8"	3-5/16"	Roller	1,000
HD-4200-FLD-RB	2"	Ductile Iron [Flanged]	4-1/2" x 6-1/4"	2-7/16" x 4-15/16"	1/2"	5-5/8"	3-5/16"	Roller	1,000
HD-4200-UN-RB	2"	Star-Tech Urethane	4-1/2" x 6-1/4"	2-7/16" x 4-15/16"	1/2"	5-5/8"	3-5/16"	Roller	600
HD-4200-UC-RB	2"	Urethane on Cast	4-1/2" x 6-1/4"	2-7/16" x 4-15/16"	1/2"	5-5/8"	3-5/16"	Roller	700
HD-4200C-UC-RB	2"	Urethane on Cast [Crowned]	4-1/2" x 6-1/4"	2-7/16" x 4-15/16"	1/2"	5-5/8"	3-5/16"	Roller	800
HD-4200C-ES-HRB	2"	Solid Elastomer [Crowned]	4-1/2" x 6-1/4"	2-7/16" x 4-15/16"	1/2"	5-5/8"	3-5/16"	HD Roller	800
HD-4200-EL-RB	2"	Eliminator Grey Rubber	4-1/2" x 6-1/4"	2-7/16" x 4-15/16"	1/2"	5-5/8"	3-5/16"	Roller	600
HD-4200-RMC-RB	2"	Rubber Moldon [H90]	4-1/2" x 6-1/4"	2-7/16" x 4-15/16"	1/2"	5-5/8"	3-5/16"	Roller	700
HD-4200-NL-RB	2"	Ny-Lite	4-1/2" x 6-1/4"	2-7/16" x 4-15/16"	1/2"	5-5/8"	3-5/16"	Roller	500
<b>5" Ø wheels</b>									
HD-5200-BAL-RB	2"	Phenolic	4-1/2" x 6-1/4"	2-7/16" x 4-15/16"	1/2"	6-1/2"	3-3/4"	Roller	1,000
HD-5200-LAM-RB	2"	Laminated Phenolic	4-1/2" x 6-1/4"	2-7/16" x 4-15/16"	1/2"	6-1/2"	3-3/4"	Roller	1,000
HD-5200-HT-RB	2"	Hi-Temp Phenolic	4-1/2" x 6-1/4"	2-7/16" x 4-15/16"	1/2"	6-1/2"	3-3/4"	Roller	750
HD-5200-BST-RB	2"	Cast Steel	4-1/2" x 6-1/4"	2-7/16" x 4-15/16"	1/2"	6-1/2"	3-3/4"	Roller	825
HD-5200-VG-RB	2"	Cast Steel [V-Groove]	4-1/2" x 6-1/4"	2-7/16" x 4-15/16"	1/2"	6-1/2"	3-3/4"	Roller	800
HD-5200C-DU-RB	2"	Ductile Iron [Crowned]	4-1/2" x 6-1/4"	2-7/16" x 4-15/16"	1/2"	6-1/2"	3-3/4"	Roller	1,000
HD-5200-VGD-RB	2"	Ductile Iron [V-Groove]	4-1/2" x 6-1/4"	2-7/16" x 4-15/16"	1/2"	6-1/2"	3-3/4"	Roller	1,000
HD-5200-FLD-RB	2"	Ductile Iron [Flanged]	4-1/2" x 6-1/4"	2-7/16" x 4-15/16"	1/2"	6-1/2"	3-3/4"	Roller	1,000
HD-5200-UN-RB	2"	Star-Tech Urethane	4-1/2" x 6-1/4"	2-7/16" x 4-15/16"	1/2"	6-1/2"	3-3/4"	Roller	750
HD-5200-UC-RB	2"	Urethane on Cast	4-1/2" x 6-1/4"	2-7/16" x 4-15/16"	1/2"	6-1/2"	3-3/4"	Roller	1,000
HD-5200C-UC-RB	2"	Urethane on Cast [Crowned]	4-1/2" x 6-1/4"	2-7/16" x 4-15/16"	1/2"	6-1/2"	3-3/4"	Roller	1,000
HD-5200C-ES-HRB	2"	Solid Elastomer [Crowned]	4-1/2" x 6-1/4"	2-7/16" x 4-15/16"	1/2"	6-1/2"	3-3/4"	HD Roller	1,000
HD-5200-EL-RB	2"	Eliminator Grey Rubber	4-1/2" x 6-1/4"	2-7/16" x 4-15/16"	1/2"	6-1/2"	3-3/4"	Roller	700
HD-5200-RMC-RB	2"	Rubber Moldon [H90]	4-1/2" x 6-1/4"	2-7/16" x 4-15/16"	1/2"	6-1/2"	3-3/4"	Roller	800
HD-5200-NL-RB	2"	Ny-Lite	4-1/2" x 6-1/4"	2-7/16" x 4-15/16"	1/2"	6-1/2"	3-3/4"	Roller	650

### Options

- [1] Use 'HDR' instead of 'HD' when ordering RIGID casters.
- [2] Pedal brake available on swivels and rigids. Add code 'BR' to order number. [ example: HD/BR-8200-BST-RB ]
- [3] Four Position Swivel Lock. Add code '4SL' to order number. [ example: HD/4SL-5200-EL-RB ]
- [4] Head seals available on swivels only. Add code 'HS' to order number. [ example: HD/HS-4200-NL-RB ]
- [5] Delrin bearing. Substitute 'DEL' for 'RB' in order number. [ example: HD-4200-MR-DEL ]
- [6] Heavy duty roller bearing. Substitute 'HRB' for 'RB' in order number. [ example: HD-6200C-DU-HRB ]
- [7] Flanged brass bearing. Substitute 'BF' for 'RB' in order number. [ example: HD-6200-HT-BF ]
- [8] Flanged precision bearing. Substitute 'FLPBB' for 'RB' in order number. [ example: HD-5200-LAM-FLPBB ]
- [9] \*Bolt hole pattern is slotted to 3-3/8" x 5-1/4".

# HD/HDR SERIES

1,200 lbs maximum capacity

## HD swivel casters and HDR rigid casters

This is a heavier duty version of our proven Bestway series casters. It's improved features include; a high-capacity 3/4" nut and bolt kingpin, larger upper and lower ball races featuring 3/8" and 5/16" diameter hardened ball bearings respectively, a larger [ 4-1/2" x 6-1/4" ] industry standard top plate, and reinforced legs on both swivels and rigids. Plate has 3-3/8" x 5-1/4" slotted mounting holes for flexible mounting. The zinc plate finish and a grease fitting in the swivel head, this caster is ideal for higher capacity applications. North American made for fast delivery and competitive pricing. Fully customizable upon request. Also available in [stainless steel](#). Use 'HDR' instead of 'HD' in the order number, when ordering RIGID casters.



HD-6200-HT-RB

Order number	Tread width	Wheel type	Plate size	Bolt hole pattern*	Bolt size	Overall height	Swivel radius	Bearing type	Load cap.
<b>6" Ø wheels</b>									
HD-6200-BAL-RB	2"	Phenolic	4-1/2" x 6-1/4"	2-7/16" x 4-15/16"	1/2"	7-1/2"	4-5/8"	Roller	1,200
HD-6200-LAM-RB	2"	Laminated Phenolic	4-1/2" x 6-1/4"	2-7/16" x 4-15/16"	1/2"	7-1/2"	4-5/8"	Roller	1,200
HD-6200-HT-RB	2"	Hi-Temp Phenolic	4-1/2" x 6-1/4"	2-7/16" x 4-15/16"	1/2"	7-1/2"	4-5/8"	Roller	900
HD-6200-BST-RB	2"	Cast Steel	4-1/2" x 6-1/4"	2-7/16" x 4-15/16"	1/2"	7-1/2"	4-5/8"	Roller	1,000
HD-6200-VG-RB	2"	Cast Steel [V-Groove]	4-1/2" x 6-1/4"	2-7/16" x 4-15/16"	1/2"	7-1/2"	4-5/8"	Roller	1,000
HD-6200C-DU-RB	2"	Ductile Iron [Crowned]	4-1/2" x 6-1/4"	2-7/16" x 4-15/16"	1/2"	7-1/2"	4-5/8"	Roller	1,200
HD-6200-VGD-RB	2"	Ductile Iron [V-Groove]	4-1/2" x 6-1/4"	2-7/16" x 4-15/16"	1/2"	7-1/2"	4-5/8"	Roller	1,200
HD-6200-FLD-RB	2"	Ductile Iron [Flanged]	4-1/2" x 6-1/4"	2-7/16" x 4-15/16"	1/2"	7-1/2"	4-5/8"	Roller	1,200
HD-6200-UN-RB	2"	Star-Tech Urethane	4-1/2" x 6-1/4"	2-7/16" x 4-15/16"	1/2"	7-1/2"	4-5/8"	Roller	900
HD-6200-UC-RB	2"	Urethane on Cast	4-1/2" x 6-1/4"	2-7/16" x 4-15/16"	1/2"	7-1/2"	4-5/8"	Roller	1,200
HD-6200C-UC-RB	2"	Urethane on Cast [Crowned]	4-1/2" x 6-1/4"	2-7/16" x 4-15/16"	1/2"	7-1/2"	4-5/8"	Roller	1,050
HD-6200-ES-HRB	2"	Solid Elastomer	4-1/2" x 6-1/4"	2-7/16" x 4-15/16"	1/2"	7-1/2"	4-5/8"	HD Roller	1,200
HD-6200C-ES-HRB	2"	Solid Elastomer [Crowned]	4-1/2" x 6-1/4"	2-7/16" x 4-15/16"	1/2"	7-1/2"	4-5/8"	HD Roller	1,200
HD-6200-EL-RB	2"	Eliminator Grey Rubber	4-1/2" x 6-1/4"	2-7/16" x 4-15/16"	1/2"	7-1/2"	4-5/8"	Roller	900
HD-6200C-EL-RB	2"	Eliminator Grey Rubber [Crowned]	4-1/2" x 6-1/4"	2-7/16" x 4-15/16"	1/2"	7-1/2"	4-5/8"	Roller	900
HD-6200-RMC-RB	2"	Rubber Moldon [H90]	4-1/2" x 6-1/4"	2-7/16" x 4-15/16"	1/2"	7-1/2"	4-5/8"	Roller	900
HD-6200-NL-RB	2"	Ny-Lite	4-1/2" x 6-1/4"	2-7/16" x 4-15/16"	1/2"	7-1/2"	4-5/8"	Roller	800
<b>8" Ø wheels</b>									
HD-8200-BAL-RB	2"	Phenolic	4-1/2" x 6-1/4"	2-7/16" x 4-15/16"	1/2"	9-1/2"	6-3/8"	Roller	1,200
HD-8200-LAM-RB	2"	Laminated Phenolic	4-1/2" x 6-1/4"	2-7/16" x 4-15/16"	1/2"	9-1/2"	6-3/8"	Roller	1,200
HD-8200-HT-RB	2"	Hi-Temp Phenolic	4-1/2" x 6-1/4"	2-7/16" x 4-15/16"	1/2"	9-1/2"	6-3/8"	Roller	1,100
HD-8200-BST-RB	2"	Cast Steel	4-1/2" x 6-1/4"	2-7/16" x 4-15/16"	1/2"	9-1/2"	6-3/8"	Roller	1,200
HD-8200C-DU-RB	2"	Ductile Iron [Crowned]	4-1/2" x 6-1/4"	2-7/16" x 4-15/16"	1/2"	9-1/2"	6-3/8"	Roller	1,200
HD-8200-VGD-RB	2"	Ductile Iron [V-Groove]	4-1/2" x 6-1/4"	2-7/16" x 4-15/16"	1/2"	9-1/2"	6-3/8"	Roller	1,200
HD-8200-FLD-RB	2"	Ductile Iron [Flanged]	4-1/2" x 6-1/4"	2-7/16" x 4-15/16"	1/2"	9-1/2"	6-3/8"	Roller	1,200
HD-8200-UN-RB	2"	Star-Tech Urethane	4-1/2" x 6-1/4"	2-7/16" x 4-15/16"	1/2"	9-1/2"	6-3/8"	Roller	1,000
HD-8200-UC-RB	2"	Urethane on Cast	4-1/2" x 6-1/4"	2-7/16" x 4-15/16"	1/2"	9-1/2"	6-3/8"	Roller	1,200
HD-8200C-UC-RB	2"	Urethane on Cast [Crowned]	4-1/2" x 6-1/4"	2-7/16" x 4-15/16"	1/2"	9-1/2"	6-3/8"	Roller	1,200
HD-8200-ES-HRB	2"	Solid Elastomer	4-1/2" x 6-1/4"	2-7/16" x 4-15/16"	1/2"	9-1/2"	6-3/8"	HD Roller	1,200
HD-8200C-ES-HRB	2"	Solid Elastomer [Crowned]	4-1/2" x 6-1/4"	2-7/16" x 4-15/16"	1/2"	9-1/2"	6-3/8"	HD Roller	1,200
HD-8200-EL-RB	2"	Eliminator Grey Rubber	4-1/2" x 6-1/4"	2-7/16" x 4-15/16"	1/2"	9-1/2"	6-3/8"	Roller	900
HD-8200C-EL-RB	2"	Eliminator Grey Rubber [Crowned]	4-1/2" x 6-1/4"	2-7/16" x 4-15/16"	1/2"	9-1/2"	6-3/8"	Roller	900
HD-8200-RMC-RB	2"	Rubber Moldon [H90]	4-1/2" x 6-1/4"	2-7/16" x 4-15/16"	1/2"	9-1/2"	6-3/8"	Roller	1,000
HD-8200-NL-RB	2"	Ny-Lite	4-1/2" x 6-1/4"	2-7/16" x 4-15/16"	1/2"	9-1/2"	6-3/8"	Roller	1,000

# LH/LHR SERIES

1,500 lbs maximum capacity

## LH swivel casters and LHR rigid casters

The LH Series is designed for those applications that call for a Light Heavy-Duty caster. This caster uses the same high-capacity 3/4" nut and bolt kingpin design as our popular HD Series, but with a heavy duty 3/4" axle and wider leg spacing to accommodate a 2-1/2" tread width wheel. Plate has 3-3/8" x 5-1/4" slotted mounting holes for flexible mounting. This high quality North American made caster is an excellent alternative for those in-between jobs. Also available in [stainless steel](#). Use 'LHR' instead of 'LH' in the order number, when ordering RIGID casters.

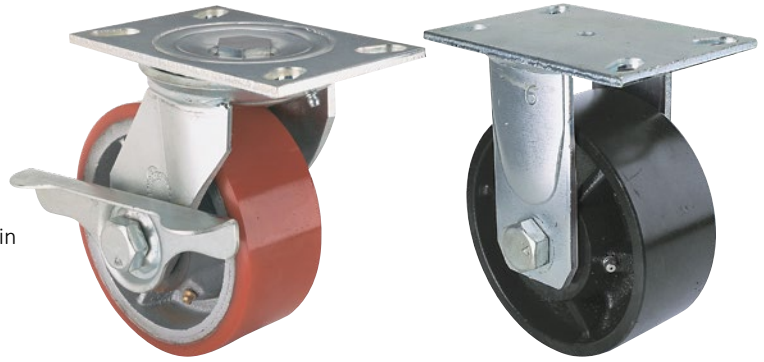

LH/BR-6250S-UC-RB

LHR-6250S-DU-RB

Order number	Tread width	Wheel type	Plate size	Bolt hole pattern*	Bolt size	Overall height	Swivel radius	Bearing type	Load cap.
<b>6" ø wheels</b>									
LH-6250S-BAL-RB	2-1/2"	Phenolic	4-1/2" x 6-1/4"	2-7/16" x 4-15/16"	1/2"	7-1/2"	4-5/8"	Roller	1,500
LH-6250S-DU-RB	2-1/2"	Ductile Iron	4-1/2" x 6-1/4"	2-7/16" x 4-15/16"	1/2"	7-1/2"	4-5/8"	Roller	1,500
LH-6250S-VGD-RB	2-1/2"	Ductile Iron [V-Groove]	4-1/2" x 6-1/4"	2-7/16" x 4-15/16"	1/2"	7-1/2"	4-5/8"	Roller	1,500
LH-6250S-UC-RB	2-1/2"	Urethane on Cast	4-1/2" x 6-1/4"	2-7/16" x 4-15/16"	1/2"	7-1/2"	4-5/8"	Roller	1,500
LH-6250S-RMC-RB	2-1/2"	Rubber Moldon [H90]	4-1/2" x 6-1/4"	2-7/16" x 4-15/16"	1/2"	7-1/2"	4-5/8"	Roller	1,100
<b>8" ø wheels</b>									
LH-8250S-BAL-RB	2-1/2"	Phenolic	4-1/2" x 6-1/4"	2-7/16" x 4-15/16"	1/2"	10-1/8"	6-1/2"	Roller	1,500
LH-8250S-DU-RB	2-1/2"	Ductile Iron	4-1/2" x 6-1/4"	2-7/16" x 4-15/16"	1/2"	10-1/8"	6-1/2"	Roller	1,500
LH-8250S-VGD-RB	2-1/2"	Ductile Iron [V-Groove]	4-1/2" x 6-1/4"	2-7/16" x 4-15/16"	1/2"	10-1/8"	6-1/2"	Roller	1,500
LH-8250S-UC-RB	2-1/2"	Urethane on Cast	4-1/2" x 6-1/4"	2-7/16" x 4-15/16"	1/2"	10-1/8"	6-1/2"	Roller	1,500
LH-8250S-RMC-RB	2-1/2"	Rubber Moldon [H90]	4-1/2" x 6-1/4"	2-7/16" x 4-15/16"	1/2"	10-1/8"	6-1/2"	Roller	1,500
<b>10" ø wheels</b>									
LH-10250S-BAL-RB	2-1/2"	Phenolic	4-1/2" x 6-1/4"	2-7/16" x 4-15/16"	1/2"	11-1/2"	7-3/4"	Roller	1,500
LH-10250S-DU-RB	2-1/2"	Ductile Iron	4-1/2" x 6-1/4"	2-7/16" x 4-15/16"	1/2"	11-1/2"	7-3/4"	Roller	1,500
LH-10250S-UC-RB	2-1/2"	Urethane on Cast	4-1/2" x 6-1/4"	2-7/16" x 4-15/16"	1/2"	11-1/2"	7-3/4"	Roller	1,500
LH-10250SC-UBA-PBB	2-1/2"	Urethane on Alum. [Crowned]	4-1/2" x 6-1/4"	2-7/16" x 4-15/16"	1/2"	11-1/2"	7-3/4"	Precision Ball	1,500
LH-10250SC-MBA-PBB	2-1/2"	Megabest [Crowned]	4-1/2" x 6-1/4"	2-7/16" x 4-15/16"	1/2"	11-1/2"	7-3/4"	Precision Ball	1,000
LH-10250S-RMC-RB	2-1/2"	Rubber Moldon [H90]	4-1/2" x 6-1/4"	2-7/16" x 4-15/16"	1/2"	11-1/2"	7-3/4"	Roller	1,500

## Options

- [1] Use 'LHR' instead of 'LH' when ordering RIGID casters.
  - [2] Pedal brake available on swivels and rigids. Add code 'BR' to order number. [example: LH/BR-8250S-DU-RB]
  - [3] Four Position Swivel Lock. Add code '4SL' to order number. [example: LH/4SL-6250S-UC-RB]
  - [4] Head seals available on swivels only. Add code 'HS' to order number. [example: LH/HS-10250SC-MBA-PBB]
  - [5] Delrin bearing. Substitute 'DEL' for 'RB' in order number. [example: LH-6250S-BAL-DEL]
  - [6] \*Bolt hole pattern is slotted to 3-3/8" x 5-1/4".
- Note:** Stainless Steel versions are available. Add code 'SS' before order number. [example: SSLH-10250SC-UBA-PBB]

# LE/LER KINGBOLTLESS SERIES

2,000 lbs maximum capacity

## LE swivel casters and LER rigid casters

The LE Series uses the same patented double ball kingboltless design as our revolutionary LD Series but takes it a step further. Our LE casters feature a larger 4-1/2" diameter swivel head locked together by over fifty 5/16" ball bearings in two precision machined raceways, a larger [4-1/2" x 6-1/4"] industry standard top plate and double welded, extra-strength formed steel fork legs. Plate has 3-3/8" x 5-1/4" slotted mounting holes for flexible mounting. Since there is no kingpin to bend or break, this caster is ideal for towline and shockload applications. Zinc plating gives an attractive appearance and a long lasting finish. Fitted with a threaded 45° angle grease fitting, for easy maintenance. North American made for fast delivery and competitive pricing. Fully customizable upon request. Also available in [stainless steel](#). Use 'LER' instead of 'LE' in the order number, when ordering RIGID casters.



LE-5200-BAL-RB

Order number	Tread width	Wheel type	Plate size	Bolt hole pattern*	Bolt size	Overall height	Swivel radius	Bearing type	Load cap.
<b>4" Ø wheels</b>									
LE-4200-BAL-RB	2"	Phenolic	4-1/2" x 6-1/4"	2-7/16" x 4-15/16"	1/2"	5-5/8"	3-3/8"	Roller	800
LE-4200-LAM-RB	2"	Laminated Phenolic	4-1/2" x 6-1/4"	2-7/16" x 4-15/16"	1/2"	5-5/8"	3-3/8"	Roller	1,200
LE-4200-HT-RB	2"	Hi-Temp Phenolic	4-1/2" x 6-1/4"	2-7/16" x 4-15/16"	1/2"	5-5/8"	3-3/8"	Roller	500
LE-4200C-DU-RB	2"	Ductile Iron [Crowned]	4-1/2" x 6-1/4"	2-7/16" x 4-15/16"	1/2"	5-5/8"	3-3/8"	Roller	1,750
LE-4200-VGD-RB	2"	Ductile Iron [V-Groove]	4-1/2" x 6-1/4"	2-7/16" x 4-15/16"	1/2"	5-5/8"	3-3/8"	Roller	1,500
LE-4200-FLD-RB	2"	Ductile Iron [Flanged]	4-1/2" x 6-1/4"	2-7/16" x 4-15/16"	1/2"	5-5/8"	3-3/8"	Roller	1,750
LE-4200-MS-RB	2"	Machined Steel	4-1/2" x 6-1/4"	2-7/16" x 4-15/16"	1/2"	5-5/8"	3-3/8"	Roller	1,750
LE-4200-UN-RB	2"	Star-Tech Urethane	4-1/2" x 6-1/4"	2-7/16" x 4-15/16"	1/2"	5-5/8"	3-3/8"	Roller	600
LE-4200-UC-RB	2"	Urethane on Cast	4-1/2" x 6-1/4"	2-7/16" x 4-15/16"	1/2"	5-5/8"	3-3/8"	Roller	700
LE-4200C-UC-RB	2"	Urethane on Cast [Crowned]	4-1/2" x 6-1/4"	2-7/16" x 4-15/16"	1/2"	5-5/8"	3-3/8"	Roller	800
LE-4200C-UBA-PBB	2"	Urethane on Alum. [Crowned]	4-1/2" x 6-1/4"	2-7/16" x 4-15/16"	1/2"	5-5/8"	3-3/8"	Precision Ball	900
LE-4200C-MBA-PBB	2"	Megabest [Crowned]	4-1/2" x 6-1/4"	2-7/16" x 4-15/16"	1/2"	5-5/8"	3-3/8"	Precision Ball	300
LE-4200C-ES-PBB	2"	Solid Elastomer [Crowned]	4-1/2" x 6-1/4"	2-7/16" x 4-15/16"	1/2"	5-5/8"	3-3/8"	Precision Ball	800
LE-4200-EL-RB	2"	Eliminator Grey Rubber	4-1/2" x 6-1/4"	2-7/16" x 4-15/16"	1/2"	5-5/8"	3-3/8"	Roller	600
LE-4200-SEZ-PBB	2"	Swivel-Eaz Urethane on Alum.	4-1/2" x 6-1/4"	2-7/16" x 4-15/16"	1/2"	5-5/8"	3-3/8"	Precision Ball	900
<b>5" Ø wheels</b>									
LE-5200-BAL-RB	2"	Phenolic	4-1/2" x 6-1/4"	2-7/16" x 4-15/16"	1/2"	6-1/2"	4"	Roller	1,000
LE-5200-LAM-RB	2"	Laminated Phenolic	4-1/2" x 6-1/4"	2-7/16" x 4-15/16"	1/2"	6-1/2"	4"	Roller	1,400
LE-5200-HT-RB	2"	Hi-Temp Phenolic	4-1/2" x 6-1/4"	2-7/16" x 4-15/16"	1/2"	6-1/2"	4"	Roller	750
LE-5200C-DU-RB	2"	Ductile Iron [Crowned]	4-1/2" x 6-1/4"	2-7/16" x 4-15/16"	1/2"	6-1/2"	4"	Roller	1,750
LE-5200C-VGD-RB	2"	Ductile Iron [V-Groove]	4-1/2" x 6-1/4"	2-7/16" x 4-15/16"	1/2"	6-1/2"	4"	Roller	1,500
LE-5200-FLD-RB	2"	Ductile Iron [Flanged]	4-1/2" x 6-1/4"	2-7/16" x 4-15/16"	1/2"	6-1/2"	4"	Roller	1,750
LE-5200-MS-RB	2"	Machined Steel	4-1/2" x 6-1/4"	2-7/16" x 4-15/16"	1/2"	6-1/2"	4"	Roller	1,750
LE-5200-UN-RB	2"	Star-Tech Urethane	4-1/2" x 6-1/4"	2-7/16" x 4-15/16"	1/2"	6-1/2"	4"	Roller	750
LE-5200-UC-RB	2"	Urethane on Cast	4-1/2" x 6-1/4"	2-7/16" x 4-15/16"	1/2"	6-1/2"	4"	Roller	1,050
LE-5200C-UC-RB	2"	Urethane on Cast [Crowned]	4-1/2" x 6-1/4"	2-7/16" x 4-15/16"	1/2"	6-1/2"	4"	Roller	1,000
LE-5200C-UBA-PBB	2"	Urethane on Alum. [Crowned]	4-1/2" x 6-1/4"	2-7/16" x 4-15/16"	1/2"	6-1/2"	4"	Precision Ball	900
LE-5200C-MBA-PBB	2"	Megabest [Crowned]	4-1/2" x 6-1/4"	2-7/16" x 4-15/16"	1/2"	6-1/2"	4"	Precision Ball	300
LE-5200C-ES-PBB	2"	Solid Elastomer [Crowned]	4-1/2" x 6-1/4"	2-7/16" x 4-15/16"	1/2"	6-1/2"	4"	Precision Ball	1,000
LE-5200-EL-RB	2"	Eliminator Grey Rubber	4-1/2" x 6-1/4"	2-7/16" x 4-15/16"	1/2"	6-1/2"	4"	Roller	700

## Options

- [1] Use 'LER' instead of 'LE' when ordering RIGID casters.
- [2] Pedal brake available on swivels and rigids. Add code 'BR' to order number. [ example: LE/BR-8200C-DU-RB ]
- [3] Four Position Swivel Lock. Add code '4SL' to order number. [ example: LE/4SL-5200-UC-RB ]
- [4] Head seals available on swivels only. Add code 'HS' to order number. [ example: LE/HS-4200-EL-RB ]
- [5] Heavy duty roller bearing. Substitute 'HRB' for 'RB' in order number. [ example: LE-6200C-DU-HRB ]
- [6] Flanged brass bearing. Substitute 'BF' for 'RB' in order number. [ example: LE-6200-HT-BF ]
- [7] Flanged precision bearing. Substitute 'FLPBB' for 'RB' in order number. [ example: LE-5200-LAM-FLPBB ]
- [8] \*Bolt hole pattern is slotted to 3-3/8" x 5-1/4".

# LE/LER KINGBOLTLESS SERIES

2,000 lbs maximum capacity

## LE swivel casters and LER rigid casters

The LE Series uses the same patented double ball kingboltless design as our revolutionary LD Series but takes it a step further. Our LE casters feature a larger 4-1/2" diameter swivel head locked together by over fifty 5/16" ball bearings in two precision machined raceways, a larger [ 4-1/2" x 6-1/4" ] industry standard top plate and double welded, extra-strength formed steel fork legs. Plate has 3-3/8" x 5-1/4" slotted mounting holes for flexible mounting. Since there is no kingpin to bend or break, this caster is ideal for towline and shockload applications. Zinc plating gives an attractive appearance and a long lasting finish. Fitted with a threaded 45° angle grease fitting, for easy maintenance. North American made for fast delivery and competitive pricing. Fully customizable upon request. Also available in [stainless steel](#). Use 'LER' instead of 'LE' in the order number, when ordering RIGID casters.



LER-8200C-EG-PBB

Order number	Tread width	Wheel type	Plate size	Bolt hole pattern*	Bolt size	Overall height	Swivel radius	Bearing type	Load cap.
<b>6" ø wheels</b>									
LE-6200-BAL-RB	2"	Phenolic	4-1/2" x 6-1/4"	2-7/16" x 4-15/16"	1/2"	7-1/2"	4-3/8"	Roller	1,200
LE-6200-LAM-RB	2"	Laminated Phenolic	4-1/2" x 6-1/4"	2-7/16" x 4-15/16"	1/2"	7-1/2"	4-3/8"	Roller	1,500
LE-6200-HT-RB	2"	Hi-Temp Phenolic	4-1/2" x 6-1/4"	2-7/16" x 4-15/16"	1/2"	7-1/2"	4-3/8"	Roller	900
LE-6200C-DU-RB	2"	Ductile Iron [Crowned]	4-1/2" x 6-1/4"	2-7/16" x 4-15/16"	1/2"	7-1/2"	4-3/8"	Roller	1,800
LE-6200-VGD-RB	2"	Ductile Iron [V-Groove]	4-1/2" x 6-1/4"	2-7/16" x 4-15/16"	1/2"	7-1/2"	4-3/8"	Roller	1,800
LE-6200-FLD-RB	2"	Ductile Iron [Flanged]	4-1/2" x 6-1/4"	2-7/16" x 4-15/16"	1/2"	7-1/2"	4-3/8"	Roller	1,900
LE-6200-MS-RB	2"	Machined Steel	4-1/2" x 6-1/4"	2-7/16" x 4-15/16"	1/2"	7-1/2"	4-3/8"	Roller	1,900
LE-6200-UN-RB	2"	Star-Tech Urethane	4-1/2" x 6-1/4"	2-7/16" x 4-15/16"	1/2"	7-1/2"	4-3/8"	Roller	900
LE-6200-UC-RB	2"	Urethane on Cast	4-1/2" x 6-1/4"	2-7/16" x 4-15/16"	1/2"	7-1/2"	4-3/8"	Roller	1,230
LE-6200C-UC-RB	2"	Urethane on Cast [Crowned]	4-1/2" x 6-1/4"	2-7/16" x 4-15/16"	1/2"	7-1/2"	4-3/8"	Roller	1,050
LE-6200C-UBA-PBB	2"	Urethane on Alum. [Crowned]	4-1/2" x 6-1/4"	2-7/16" x 4-15/16"	1/2"	7-1/2"	4-3/8"	Precision Ball	1,200
LE-6200C-MBA-PBB	2"	Megabest [Crowned]	4-1/2" x 6-1/4"	2-7/16" x 4-15/16"	1/2"	7-1/2"	4-3/8"	Precision Ball	400
LE-6200C-ES-PBB	2"	Solid Elastomer [Crowned]	4-1/2" x 6-1/4"	2-7/16" x 4-15/16"	1/2"	7-1/2"	4-3/8"	Precision Ball	1,200
LE-6200C-EG-PBB	2"	Elastiglide [Crowned]	4-1/2" x 6-1/4"	2-7/16" x 4-15/16"	1/2"	7-1/2"	4-3/8"	Precision Ball	1,200
LE-6200-EL-RB	2"	Eliminator Grey Rubber	4-1/2" x 6-1/4"	2-7/16" x 4-15/16"	1/2"	7-1/2"	4-3/8"	Roller	900
LE-6200C-EL-RB	2"	Eliminator Grey Rubber [Crowned]	4-1/2" x 6-1/4"	2-7/16" x 4-15/16"	1/2"	7-1/2"	4-3/8"	Roller	900
LE-6200-SEZ-PBB	2"	Swivel-Eaz Urethane on Alum.	4-1/2" x 6-1/4"	2-7/16" x 4-15/16"	1/2"	7-1/2"	4-3/8"	Precision Ball	1,900
<b>8" ø wheels</b>									
LE-8200-BAL-RB	2"	Phenolic	4-1/2" x 6-1/4"	2-7/16" x 4-15/16"	1/2"	9-1/2"	5-11/16"	Roller	1,400
LE-8200-LAM-RB	2"	Laminated Phenolic	4-1/2" x 6-1/4"	2-7/16" x 4-15/16"	1/2"	9-1/2"	5-11/16"	Roller	1,700
LE-8200-HT-RB	2"	Hi-Temp Phenolic	4-1/2" x 6-1/4"	2-7/16" x 4-15/16"	1/2"	9-1/2"	5-11/16"	Roller	1,100
LE-8200C-DU-RB	2"	Ductile Iron [Crowned]	4-1/2" x 6-1/4"	2-7/16" x 4-15/16"	1/2"	9-1/2"	5-11/16"	Roller	1,900
LE-8200-VGD-RB	2"	Ductile Iron [V-Groove]	4-1/2" x 6-1/4"	2-7/16" x 4-15/16"	1/2"	9-1/2"	5-11/16"	Roller	1,900
LE-8200-FLD-RB	2"	Ductile Iron [Flanged]	4-1/2" x 6-1/4"	2-7/16" x 4-15/16"	1/2"	9-1/2"	5-11/16"	Roller	1,900
LE-8200-UN-RB	2"	Star-Tech Urethane	4-1/2" x 6-1/4"	2-7/16" x 4-15/16"	1/2"	9-1/2"	5-11/16"	Roller	1,000
LE-8200-UC-RB	2"	Urethane on Cast	4-1/2" x 6-1/4"	2-7/16" x 4-15/16"	1/2"	9-1/2"	5-11/16"	Roller	1,500
LE-8200C-UC-RB	2"	Urethane on Cast [Crowned]	4-1/2" x 6-1/4"	2-7/16" x 4-15/16"	1/2"	9-1/2"	5-11/16"	Roller	1,250
LE-8200C-UBA-PBB	2"	Urethane on Alum. [Crowned]	4-1/2" x 6-1/4"	2-7/16" x 4-15/16"	1/2"	9-1/2"	5-11/16"	Precision Ball	1,500
LE-8200C-MBA-PBB	2"	Megabest [Crowned]	4-1/2" x 6-1/4"	2-7/16" x 4-15/16"	1/2"	9-1/2"	5-11/16"	Precision Ball	500
LE-8200C-ES-PBB	2"	Solid Elastomer [Crowned]	4-1/2" x 6-1/4"	2-7/16" x 4-15/16"	1/2"	9-1/2"	5-11/16"	Precision Ball	1,600
LE-8200C-EG-PBB	2"	Elastiglide [Crowned]	4-1/2" x 6-1/4"	2-7/16" x 4-15/16"	1/2"	9-1/2"	5-11/16"	Precision Ball	1,500
LE-8200-EL-RB	2"	Eliminator Grey Rubber	4-1/2" x 6-1/4"	2-7/16" x 4-15/16"	1/2"	9-1/2"	5-11/16"	Roller	900
LE-8200C-EL-RB	2"	Eliminator Grey Rubber [Crowned]	4-1/2" x 6-1/4"	2-7/16" x 4-15/16"	1/2"	9-1/2"	5-11/16"	Roller	900
LE-8200-SEZ-PBB	2"	Swivel-Eaz Urethane on Alum.	4-1/2" x 6-1/4"	2-7/16" x 4-15/16"	1/2"	9-1/2"	5-11/16"	Precision Ball	2,000

# LS/LSR KINGBOLTLESS SERIES

3,500 lbs maximum capacity

## LS swivel casters and LSR rigid casters

Our LS Series caster uses our patented double ball kingboltless design to eliminate the need for rivets or kingbolts, a common cause of caster failures. This caster offers higher capacities and greater durability than traditional forged head designs; it is engineered to withstand punishing towline and shockload applications that would destroy most ordinary casters! The LS swivel uses 4-1/2" diameter precision machined and hardened raceways with over fifty 5/16" diameter ball bearings in two raceways, securely welded to an industry standard 4-1/2" x 6-1/4" top plate. Plate has 3-3/8" x 5-1/4" slotted mounting holes. The caster is painted with a high gloss black finish and is fitted with a threaded 45° angle grease fitting for easy maintenance. North American made for fast delivery and competitive pricing. Customizable upon request. Also available in [stainless steel](#). Use 'LSR' instead of 'LS' in the order number, when ordering RIGID casters.



LS-6300-DU-RB

Order number	Tread width	Wheel type	Plate size	Bolt hole pattern*	Bolt size	Overall height	Swivel radius	Bearing type	Load cap.
<b>6" ø wheels</b>									
LS-6250L-BAL-RB	2-1/2"	Phenolic	4-1/2" x 6-1/4"	2-7/16" x 4-15/16"	1/2"	7-1/2"	5-1/2"	Roller	1,600
LS-6250L-DU-RB	2-1/2"	Ductile Iron	4-1/2" x 6-1/4"	2-7/16" x 4-15/16"	1/2"	7-1/2"	5-1/2"	Roller	3,500
LS-6250L-VGD-RB	2-1/2"	Ductile Iron [V-Groove]	4-1/2" x 6-1/4"	2-7/16" x 4-15/16"	1/2"	7-1/2"	5-1/2"	Roller	3,500
LS-6250L-UC-RB	2-1/2"	Urethane on Cast	4-1/2" x 6-1/4"	2-7/16" x 4-15/16"	1/2"	7-1/2"	5-1/2"	Roller	1,600
LS-6300-BAL-RB	3"	Phenolic	4-1/2" x 6-1/4"	2-7/16" x 4-15/16"	1/2"	7-1/2"	5-1/2"	Roller	2,000
LS-6300-LAM-RB	3"	Laminated Phenolic	4-1/2" x 6-1/4"	2-7/16" x 4-15/16"	1/2"	7-1/2"	5-1/2"	Roller	2,500
LS-6300-DU-RB	3"	Ductile Iron	4-1/2" x 6-1/4"	2-7/16" x 4-15/16"	1/2"	7-1/2"	5-1/2"	Roller	3,500
LS-6300-VGD-RB	3"	Ductile Iron [V-Groove]	4-1/2" x 6-1/4"	2-7/16" x 4-15/16"	1/2"	7-1/2"	5-1/2"	Roller	3,500
LS-6300-UC-RB	3"	Urethane on Cast	4-1/2" x 6-1/4"	2-7/16" x 4-15/16"	1/2"	7-1/2"	5-1/2"	Roller	2,050
LS-6300C-UBA-PBB	3"	Urethane on Alum. [Crowned]	4-1/2" x 6-1/4"	2-7/16" x 4-15/16"	1/2"	7-1/2"	5-1/2"	Precision Ball	2,100
LS-6300-MBA-PBB	3"	Megabest	4-1/2" x 6-1/4"	2-7/16" x 4-15/16"	1/2"	7-1/2"	5-1/2"	Precision Ball	700
LS-6300-UDU-RB	3"	Urethane on Ductile Iron	4-1/2" x 6-1/4"	2-7/16" x 4-15/16"	1/2"	7-1/2"	5-1/2"	Roller	3,500
LS-6300-RMC-RB	3"	Rubber Moldon [H90]	4-1/2" x 6-1/4"	2-7/16" x 4-15/16"	1/2"	7-1/2"	5-1/2"	Roller	1,360
<b>8" ø wheels</b>									
LS-8250L-BAL-RB	2-1/2"	Phenolic	4-1/2" x 6-1/4"	2-7/16" x 4-15/16"	1/2"	10-1/8"	6-1/2"	Roller	2,000
LS-8250L-DU-RB	2-1/2"	Ductile Iron	4-1/2" x 6-1/4"	2-7/16" x 4-15/16"	1/2"	10-1/8"	6-1/2"	Roller	3,500
LS-8250L-VGD-RB	2-1/2"	Ductile Iron [V-Groove]	4-1/2" x 6-1/4"	2-7/16" x 4-15/16"	1/2"	10-1/8"	6-1/2"	Roller	3,500
LS-8250L-UC-RB	2-1/2"	Urethane on Cast	4-1/2" x 6-1/4"	2-7/16" x 4-15/16"	1/2"	10-1/8"	6-1/2"	Roller	1,800
LS-8300-BAL-RB	3"	Phenolic	4-1/2" x 6-1/4"	2-7/16" x 4-15/16"	1/2"	10-1/8"	6-1/2"	Roller	2,500
LS-8300-LAM-RB	3"	Laminated Phenolic	4-1/2" x 6-1/4"	2-7/16" x 4-15/16"	1/2"	10-1/8"	6-1/2"	Roller	3,100
LS-8300-DU-RB	3"	Ductile Iron	4-1/2" x 6-1/4"	2-7/16" x 4-15/16"	1/2"	10-1/8"	6-1/2"	Roller	3,500
LS-8300-VGD-RB	3"	Ductile Iron [V-Groove]	4-1/2" x 6-1/4"	2-7/16" x 4-15/16"	1/2"	10-1/8"	6-1/2"	Roller	3,500
LS-8300-UC-RB	3"	Urethane on Cast	4-1/2" x 6-1/4"	2-7/16" x 4-15/16"	1/2"	10-1/8"	6-1/2"	Roller	2,500
LS-8300C-UBA-PBB	3"	Urethane on Alum. [Crowned]	4-1/2" x 6-1/4"	2-7/16" x 4-15/16"	1/2"	10-1/8"	6-1/2"	Precision Ball	2,550
LS-8300-MBA-PBB	3"	Megabest	4-1/2" x 6-1/4"	2-7/16" x 4-15/16"	1/2"	10-1/8"	6-1/2"	Precision Ball	850
LS-8300-UDU-RB	3"	Urethane on Ductile Iron	4-1/2" x 6-1/4"	2-7/16" x 4-15/16"	1/2"	10-1/8"	6-1/2"	Roller	3,500
LS-8300-RMC-RB	3"	Rubber Moldon [H90]	4-1/2" x 6-1/4"	2-7/16" x 4-15/16"	1/2"	10-1/8"	6-1/2"	Roller	1,680

## Options

- [1] Use 'LSR' instead of 'LS' when ordering RIGID casters.
- [2] Pedal brake available on swivels and rigids. Add code 'BR' to order number. [example: LS/BR-8300-DU-RB]
- [3] Poly Cam Brake available on swivels and rigids. Add code 'PCB' to order number. [example: LS/PCB-6300-UC-RB]
- [4] Knob Handle Brake available on swivels and rigids. Add code 'KBR' to order number. [example: LS/KBR-6250L-UC-RB]
- [5] Four Position Swivel Lock. Add code '4SL' to order number. [example: LS/4SL-12300-BAL-RB]
- [6] Head seals available on swivels only. Add code 'HS' to order number. [example: LS/HS-10250SC-UBA-PBB]
- [7] Flanged brass bearing. Substitute 'BF' for 'RB' in order number. [example: LS-6300-LAM-BF]
- [8] Flanged precision bearing. Substitute 'FLPBB' for 'RB' in order number. [example: LS-8300-BAL-FLPBB]
- [9] \*Bolt hole pattern is slotted to 3-3/8" x 5-1/4".

# LS/LSR KINGBOLTLESS SERIES

3,500 lbs maximum capacity

## LS swivel casters and LSR rigid casters

Our LS Series caster uses our patented double ball kingboltless design to eliminate the need for rivets or kingbolts, a common cause of caster failures. This caster offers higher capacities and greater durability than traditional forged head designs; it is engineered to withstand punishing towline and shockload applications that would destroy most ordinary casters! The LS swivel uses 4-1/2" diameter precision machined and hardened raceways with over fifty 5/16" diameter ball bearings in two raceways, securely welded to an industry standard 4-1/2" x 6-1/4" top plate. Plate has 3-3/8" x 5-1/4" slotted mounting holes. The caster is painted with a high gloss black finish and is fitted with a threaded 45° angle grease fitting for easy maintenance. North American made for fast delivery and competitive pricing. Customizable upon request. Also available in [stainless steel](#). Use 'LSR' instead of 'LS' in the order number, when ordering RIGID casters.



LS-6300-DU-RB

Order number	Tread width	Wheel type	Plate size	Bolt hole pattern*	Bolt size	Overall height	Swivel radius	Bearing type	Load cap.
<b>10" Ø wheels</b>									
LS-10250L-BAL-RB	2-1/2"	Phenolic	4-1/2" x 6-1/4"	2-7/16" x 4-15/16"	1/2"	11-1/2"	7-3/4"	Roller	2,400
LS-10250L-DU-RB	2-1/2"	Ductile Iron	4-1/2" x 6-1/4"	2-7/16" x 4-15/16"	1/2"	11-1/2"	7-3/4"	Roller	3,500
LS-10250L-UC-RB	2-1/2"	Urethane on Cast	4-1/2" x 6-1/4"	2-7/16" x 4-15/16"	1/2"	11-1/2"	7-3/4"	Roller	2,300
LS-10250SC-UBA-PBB	2-1/2"	Urethane on Alum. [Crowned]	4-1/2" x 6-1/4"	2-7/16" x 4-15/16"	1/2"	11-1/2"	7-3/4"	Precision Ball	3,000
LS-10250SC-MBA-PBB	2-1/2"	Megabest [Crowned]	4-1/2" x 6-1/4"	2-7/16" x 4-15/16"	1/2"	11-1/2"	7-3/4"	Precision Ball	1,000
LS-10300-BAL-RB	3"	Phenolic	4-1/2" x 6-1/4"	2-7/16" x 4-15/16"	1/2"	11-1/2"	7-3/4"	Roller	2,500
LS-10300-DU-RB	3"	Ductile Iron	4-1/2" x 6-1/4"	2-7/16" x 4-15/16"	1/2"	11-1/2"	7-3/4"	Roller	3,500
LS-10300-VGD-RB	3"	Ductile Iron [V-Groove]	4-1/2" x 6-1/4"	2-7/16" x 4-15/16"	1/2"	11-1/2"	7-3/4"	Roller	3,500
LS-10300-UC-RB	3"	Urethane on Cast	4-1/2" x 6-1/4"	2-7/16" x 4-15/16"	1/2"	11-1/2"	7-3/4"	Roller	2,800
LS-10300-UDU-RB	3"	Urethane on Ductile Iron	4-1/2" x 6-1/4"	2-7/16" x 4-15/16"	1/2"	11-1/2"	7-3/4"	Roller	3,500
LS-10300-RMC-RB	3"	Rubber Moldon [H90]	4-1/2" x 6-1/4"	2-7/16" x 4-15/16"	1/2"	11-1/2"	7-3/4"	Roller	2,000
<b>12" Ø wheels</b>									
LS-12300-BAL-RB	3"	Phenolic	4-1/2" x 6-1/4"	2-7/16" x 4-15/16"	1/2"	13-1/2"	9"	Roller	3,500
LS-12300-DU-RB	3"	Ductile Iron	4-1/2" x 6-1/4"	2-7/16" x 4-15/16"	1/2"	13-1/2"	9"	Roller	3,500
LS-12300-VGD-RB	3"	Ductile Iron [V-Groove]	4-1/2" x 6-1/4"	2-7/16" x 4-15/16"	1/2"	13-1/2"	9"	Roller	3,500
LS-12300-UC-RB	3"	Urethane on Cast	4-1/2" x 6-1/4"	2-7/16" x 4-15/16"	1/2"	13-1/2"	9"	Roller	3,200
LS-12300-UDU-RB	3"	Urethane on Ductile Iron	4-1/2" x 6-1/4"	2-7/16" x 4-15/16"	1/2"	13-1/2"	9"	Roller	3,500
LS-12300-RMC-RB	3"	Rubber Moldon [H90]	4-1/2" x 6-1/4"	2-7/16" x 4-15/16"	1/2"	13-1/2"	9"	Roller	2,280

# SX/SXR KINGBOLTLESS SERIES

4,600 lbs maximum capacity

## SX swivel casters and SXR rigid casters

This robust caster has been designed to incorporate our patented double ball kingboltless raceways. The 5-1/2" diameter swivel head, precision machined and heat treated for durability, is locked together by over fifty 3/8" diameter ball bearings. Top plate has slotted mounting holes to 4-1/8" x 6-1/8" for flexible mounting. Without a kingpin to bend or break as in traditional forged head designs, this caster can withstand punishing towline and shockload applications. The caster is painted with a high gloss black finish and is fitted with a threaded 45° angle grease fitting for easy maintenance. North American made for fast delivery and competitive pricing. Fully customizable upon request. Use 'SXR' instead of 'SX' in the order number, when ordering RIGID casters.



SX-8300-MBA-PBB

Order number	Tread width	Wheel type	Plate size	Bolt hole pattern*	Bolt size	Overall height	Swivel radius	Bearing type	Load cap.
<b>6" ø wheels</b>									
SX-6250L-BAL-RB	2-1/2"	Phenolic	5-1/4" x 7-1/4"	3-3/8" x 5-1/4"	1/2"	8"	5-1/4"	Roller	1,600
SX-6250L-DU-RB	2-1/2"	Ductile Iron	5-1/4" x 7-1/4"	3-3/8" x 5-1/4"	1/2"	8"	5-1/4"	Roller	3,500
SX-6250-VGD-RB	2-1/2"	Ductile Iron [V-Groove]	5-1/4" x 7-1/4"	3-3/8" x 5-1/4"	1/2"	8"	5-1/4"	Roller	3,500
SX-6250L-UC-RB	2-1/2"	Urethane on Cast	5-1/4" x 7-1/4"	3-3/8" x 5-1/4"	1/2"	8"	5-1/4"	Roller	1,600
SX-6300-BAL-RB	3"	Phenolic	5-1/4" x 7-1/4"	3-3/8" x 5-1/4"	1/2"	8"	5-1/4"	Roller	2,000
SX-6300-LAM-RB	3"	Laminated Phenolic	5-1/4" x 7-1/4"	3-3/8" x 5-1/4"	1/2"	8"	5-1/4"	Roller	2,500
SX-6300-DU-RB	3"	Ductile Iron	5-1/4" x 7-1/4"	3-3/8" x 5-1/4"	1/2"	8"	5-1/4"	Roller	4,600
SX-6300-VGD-RB	3"	Ductile Iron [V-Groove]	5-1/4" x 7-1/4"	3-3/8" x 5-1/4"	1/2"	8"	5-1/4"	Roller	4,600
SX-6300-UC-RB	3"	Urethane on Cast	5-1/4" x 7-1/4"	3-3/8" x 5-1/4"	1/2"	8"	5-1/4"	Roller	2,050
SX-6300C-UBA-PBB	3"	Urethane on Alum. [Crowned]	5-1/4" x 7-1/4"	3-3/8" x 5-1/4"	1/2"	8"	5-1/4"	Precision Ball	2,100
SX-6300-MBA-PBB	3"	Megabest	5-1/4" x 7-1/4"	3-3/8" x 5-1/4"	1/2"	8"	5-1/4"	Precision Ball	700
SX-6300-UDU-RB	3"	Urethane on Ductile Iron	5-1/4" x 7-1/4"	3-3/8" x 5-1/4"	1/2"	8"	5-1/4"	Roller	4,600
SX-6300-RMC-RB	3"	Rubber Moldon [H90]	5-1/4" x 7-1/4"	3-3/8" x 5-1/4"	1/2"	8"	5-1/4"	Roller	1,360
<b>8" ø wheels</b>									
SX-8250L-BAL-RB	2-1/2"	Phenolic	5-1/4" x 7-1/4"	3-3/8" x 5-1/4"	1/2"	10-1/2"	6-1/2"	Roller	2,000
SX-8250L-DU-RB	2-1/2"	Ductile Iron	5-1/4" x 7-1/4"	3-3/8" x 5-1/4"	1/2"	10-1/2"	6-1/2"	Roller	3,500
SX-8250-VGD-RB	2-1/2"	Ductile Iron [V-Groove]	5-1/4" x 7-1/4"	3-3/8" x 5-1/4"	1/2"	10-1/2"	6-1/2"	Roller	3,500
SX-8250L-UC-RB	2-1/2"	Urethane on Cast	5-1/4" x 7-1/4"	3-3/8" x 5-1/4"	1/2"	10-1/2"	6-1/2"	Roller	1,800
SX-8300-BAL-RB	3"	Phenolic	5-1/4" x 7-1/4"	3-3/8" x 5-1/4"	1/2"	10-1/2"	6-1/2"	Roller	2,500
SX-8300-LAM-RB	3"	Laminated Phenolic	5-1/4" x 7-1/4"	3-3/8" x 5-1/4"	1/2"	10-1/2"	6-1/2"	Roller	3,100
SX-8300-DU-RB	3"	Ductile Iron	5-1/4" x 7-1/4"	3-3/8" x 5-1/4"	1/2"	10-1/2"	6-1/2"	Roller	4,600
SX-8300-VGD-RB	3"	Ductile Iron [V-Groove]	5-1/4" x 7-1/4"	3-3/8" x 5-1/4"	1/2"	10-1/2"	6-1/2"	Roller	4,600
SX-8300-UC-RB	3"	Urethane on Cast	5-1/4" x 7-1/4"	3-3/8" x 5-1/4"	1/2"	10-1/2"	6-1/2"	Roller	2,500
SX-8300C-UBA-PBB	3"	Urethane on Alum. [Crowned]	5-1/4" x 7-1/4"	3-3/8" x 5-1/4"	1/2"	10-1/2"	6-1/2"	Precision Ball	2,550
SX-8300-MBA-PBB	3"	Megabest	5-1/4" x 7-1/4"	3-3/8" x 5-1/4"	1/2"	10-1/2"	6-1/2"	Precision Ball	850
SX-8300-UDU-RB	3"	Urethane on Ductile Iron	5-1/4" x 7-1/4"	3-3/8" x 5-1/4"	1/2"	10-1/2"	6-1/2"	Roller	4,600
SX-8300-RMC-RB	3"	Rubber Moldon [H90]	5-1/4" x 7-1/4"	3-3/8" x 5-1/4"	1/2"	10-1/2"	6-1/2"	Roller	1,680

## Options

- [1] Use 'SXR' instead of 'SX' when ordering RIGID casters.
- [2] Poly Cam Brake available on swivels and rigids. Add code 'PCB' to order number. [ example: SX/PCB-6300-UC-RB ]
- [3] Knob Handle Brake available on swivels and rigids. Add code 'KBR' to order number. [ example: SX/KBR-6250L-UC-RB ]
- [4] Four Position Swivel Lock. Add code '4SL' to order number. [ example: SX/4SL-12300-BAL-RB ]
- [5] Flanged brass bearing. Substitute 'BF' for 'RB' in order number. [ example: SX-6300-LAM-BF ]
- [6] \*Bolt hole pattern is slotted to 4-1/8" x 6-1/8".



# SX/SXR KINGBOLTLESS SERIES

4,600 lbs maximum capacity

## SX swivel casters and SXR rigid casters

This robust caster has been designed to incorporate our patented double ball kingboltless raceways. The 5-1/2" diameter swivel head, precision machined and heat treated for durability, is locked together by over fifty 3/8" diameter ball bearings. Top plate has slotted mounting holes to 4-1/8" x 6-1/8" for flexible mounting. Without a kingpin to bend or break as in traditional forged head designs, this caster can withstand punishing towline and shockload applications. The caster is painted with a high gloss black finish and is fitted with a threaded 45° angle grease fitting for easy maintenance. North American made for fast delivery and competitive pricing. Fully customizable upon request. Use 'SXR' instead of 'SX' in the order number, when ordering RIGID casters.



SX-8300-BAL-RB

Order number	Tread width	Wheel type	Plate size	Bolt hole pattern*	Bolt size	Overall height	Swivel radius	Bearing type	Load cap.
<b>10" Ø wheels</b>									
SX-10250L-BAL-RB	2-1/2"	Phenolic	5-1/4" x 7-1/4"	3-3/8" x 5-1/4"	1/2"	12-1/2"	7-1/2"	Roller	2,400
SX-10250L-DU-RB	2-1/2"	Ductile Iron	5-1/4" x 7-1/4"	3-3/8" x 5-1/4"	1/2"	12-1/2"	7-1/2"	Roller	4,500
SX-10250L-UC-RB	2-1/2"	Urethane on Cast	5-1/4" x 7-1/4"	3-3/8" x 5-1/4"	1/2"	12-1/2"	7-1/2"	Roller	2,300
SX-10250SC-UBA-PBB	2-1/2"	Urethane on Alum. [Crowned]	5-1/4" x 7-1/4"	3-3/8" x 5-1/4"	1/2"	12-1/2"	7-1/2"	Precision Ball	3,000
SX-10250SC-MBA-PBB	2-1/2"	Megabest [Crowned]	5-1/4" x 7-1/4"	3-3/8" x 5-1/4"	1/2"	12-1/2"	7-1/2"	Precision Ball	1,000
SX-10300-BAL-RB	3"	Phenolic	5-1/4" x 7-1/4"	3-3/8" x 5-1/4"	1/2"	12-1/2"	7-1/2"	Roller	2,500
SX-10300-DU-RB	3"	Ductile Iron	5-1/4" x 7-1/4"	3-3/8" x 5-1/4"	1/2"	12-1/2"	7-1/2"	Roller	4,600
SX-10300-VGD-RB	3"	Ductile Iron [V-Groove]	5-1/4" x 7-1/4"	3-3/8" x 5-1/4"	1/2"	12-1/2"	7-1/2"	Roller	4,600
SX-10300-UC-RB	3"	Urethane on Cast	5-1/4" x 7-1/4"	3-3/8" x 5-1/4"	1/2"	12-1/2"	7-1/2"	Roller	2,800
SX-10300-UDU-RB	3"	Urethane on Ductile Iron	5-1/4" x 7-1/4"	3-3/8" x 5-1/4"	1/2"	12-1/2"	7-1/2"	Roller	4,600
SX-10300-RMC-RB	3"	Rubber Moldon [H90]	5-1/4" x 7-1/4"	3-3/8" x 5-1/4"	1/2"	12-1/2"	7-1/2"	Roller	2,000
<b>12" Ø wheels</b>									
SX-12300-BAL-RB	3"	Phenolic	5-1/4" x 7-1/4"	3-3/8" x 5-1/4"	1/2"	15-1/2"	8-1/2"	Roller	3,500
SX-12300-DU-RB	3"	Ductile Iron	5-1/4" x 7-1/4"	3-3/8" x 5-1/4"	1/2"	15-1/2"	8-1/2"	Roller	4,600
SX-12300-VGD-RB	3"	Ductile Iron [V-Groove]	5-1/4" x 7-1/4"	3-3/8" x 5-1/4"	1/2"	15-1/2"	8-1/2"	Roller	4,600
SX-12300-UC-RB	3"	Urethane on Cast	5-1/4" x 7-1/4"	3-3/8" x 5-1/4"	1/2"	15-1/2"	8-1/2"	Roller	3,200
SX-12300-UDU-RB	3"	Urethane on Ductile Iron	5-1/4" x 7-1/4"	3-3/8" x 5-1/4"	1/2"	15-1/2"	8-1/2"	Roller	4,600
SX-12300-RMC-RB	3"	Rubber Moldon [H90]	5-1/4" x 7-1/4"	3-3/8" x 5-1/4"	1/2"	15-1/2"	8-1/2"	Roller	2,280

# KP/KPR KINGBOLTLESS SERIES

10,000 lbs maximum capacity



KP-6400-DU-TB

## KP swivel casters and KPR rigid casters

KP Series is durable and carries heavy loads easily. Using our patented double ball kingboltless design, these casters offer unmatched performance. The durable 6-1/2" diameter swivel head is securely welded to the 1/2" top plate. The two precision machined and hardened raceways are locked together by over fifty 1/2" diameter ball bearings. The double raceways provide easier operation than single race models offered by the competition and the kingboltless design means the caster can withstand punishing topline and shockload applications. The top plate has slotted mounting holes to 4-1/8" x 6-1/8" for flexible mounting. The caster is painted with a high gloss black finish and is fitted with a threaded 45° angle grease fitting for easy maintenance. North American made for fast delivery and competitive pricing. Fully customizable upon request. Use 'KPR' instead of 'KP' in the order number, when ordering RIGID casters.

Order number	Tread width	Wheel type	Plate size	Bolt hole pattern*	Bolt size	Overall height	Swivel radius	Bearing type	Load cap.
<b>6" ø wheels</b>									
KP-6300-LAM-RB	3"	Laminated Phenolic	6-1/4" x 7-1/2"	4-1/2" x 6"	1/2"	8-1/2"	4-3/4"	Roller	2,500
KP-6300-DU-RB	3"	Ductile Iron	6-1/4" x 7-1/2"	4-1/2" x 6"	1/2"	8-1/2"	4-3/4"	Roller	6,000
KP-6300-VGD-RB	3"	Ductile Iron [V-Groove]	6-1/4" x 7-1/2"	4-1/2" x 6"	1/2"	8-1/2"	4-3/4"	Roller	5,000
KP-6300-UC-RB	3"	Urethane on Cast	6-1/4" x 7-1/2"	4-1/2" x 6"	1/2"	8-1/2"	4-3/4"	Roller	2,050
KP-6300-UDU-RB	3"	Urethane on Ductile Iron	6-1/4" x 7-1/2"	4-1/2" x 6"	1/2"	8-1/2"	4-3/4"	Roller	5,000
KP-6300-UDU-TB	3"	Urethane on Ductile Iron	6-1/4" x 7-1/2"	4-1/2" x 6"	1/2"	8-1/2"	4-3/4"	Tapered	9,000
KP-6400-DU-TB	4"	Ductile Iron	6-1/4" x 7-1/2"	4-1/2" x 6"	1/2"	8-1/2"	4-3/4"	Tapered	10,000
KP-6400-VGD-RB	4"	Ductile Iron [V-Groove]	6-1/4" x 7-1/2"	4-1/2" x 6"	1/2"	8-1/2"	4-3/4"	Tapered	10,000
KP-6400-UC-TB	4"	Urethane on Cast	6-1/4" x 7-1/2"	4-1/2" x 6"	1/2"	8-1/2"	4-3/4"	Tapered	5,750
KP-6400-UDU-TB	4"	Urethane on Ductile Iron	6-1/4" x 7-1/2"	4-1/2" x 6"	1/2"	8-1/2"	4-3/4"	Tapered	10,000
<b>8" ø wheels</b>									
KP-8300-LAM-RB	3"	Laminated Phenolic	6-1/4" x 7-1/2"	4-1/2" x 6"	1/2"	10-1/2"	6-3/16"	Roller	3,100
KP-8300-DU-RB	3"	Ductile Iron	6-1/4" x 7-1/2"	4-1/2" x 6"	1/2"	10-1/2"	6-3/16"	Roller	6,000
KP-8300-VGD-RB	3"	Ductile Iron [V-Groove]	6-1/4" x 7-1/2"	4-1/2" x 6"	1/2"	10-1/2"	6-3/16"	Roller	5,000
KP-8300-UC-RB	3"	Urethane on Cast	6-1/4" x 7-1/2"	4-1/2" x 6"	1/2"	10-1/2"	6-3/16"	Roller	2,500
KP-8300-UDU-RB	3"	Urethane on Ductile Iron	6-1/4" x 7-1/2"	4-1/2" x 6"	1/2"	10-1/2"	6-3/16"	Roller	6,000
KP-8300-UDU-TB	3"	Urethane on Ductile Iron	6-1/4" x 7-1/2"	4-1/2" x 6"	1/2"	10-1/2"	6-3/16"	Tapered	9,000
KP-8400-DU-TB	4"	Ductile Iron	6-1/4" x 7-1/2"	4-1/2" x 6"	1/2"	10-1/2"	6-3/16"	Tapered	10,000
KP-8400-VGD-RB	4"	Ductile Iron [V-Groove]	6-1/4" x 7-1/2"	4-1/2" x 6"	1/2"	10-1/2"	6-3/16"	Tapered	10,000
KP-8400-UC-TB	4"	Urethane on Cast	6-1/4" x 7-1/2"	4-1/2" x 6"	1/2"	10-1/2"	6-3/16"	Tapered	5,750
KP-8400-UDU-TB	4"	Urethane on Ductile Iron	6-1/4" x 7-1/2"	4-1/2" x 6"	1/2"	10-1/2"	6-3/16"	Tapered	10,000
<b>10" ø wheels</b>									
KP-10300-DU-RB	3"	Ductile Iron	6-1/4" x 7-1/2"	4-1/2" x 6"	1/2"	12-1/2"	7-11/16"	Roller	6,000
KP-10300-VGD-RB	3"	Ductile Iron [V-Groove]	6-1/4" x 7-1/2"	4-1/2" x 6"	1/2"	12-1/2"	7-11/16"	Roller	5,000
KP-10300-UC-RB	3"	Urethane on Cast	6-1/4" x 7-1/2"	4-1/2" x 6"	1/2"	12-1/2"	7-11/16"	Roller	2,800
KP-10300-UDU-RB	3"	Urethane on Ductile Iron	6-1/4" x 7-1/2"	4-1/2" x 6"	1/2"	12-1/2"	7-11/16"	Roller	6,000
KP-10300-UDU-TB	3"	Urethane on Ductile Iron	6-1/4" x 7-1/2"	4-1/2" x 6"	1/2"	12-1/2"	7-11/16"	Tapered	9,000
KP-10400-DU-TB	4"	Ductile Iron	6-1/4" x 7-1/2"	4-1/2" x 6"	1/2"	12-1/2"	7-11/16"	Tapered	10,000
KP-10400-VGD-RB	4"	Ductile Iron [V-Groove]	6-1/4" x 7-1/2"	4-1/2" x 6"	1/2"	12-1/2"	7-11/16"	Tapered	10,000
KP-10400-UC-TB	4"	Urethane on Cast	6-1/4" x 7-1/2"	4-1/2" x 6"	1/2"	12-1/2"	7-11/16"	Tapered	5,750
KP-10400-UDU-TB	4"	Urethane on Ductile Iron	6-1/4" x 7-1/2"	4-1/2" x 6"	1/2"	12-1/2"	7-11/16"	Tapered	10,000

## Options

- [1] Use 'KPR' instead of 'KP' when ordering RIGID casters.
- [2] Poly Cam Brake available on swivels and rigids. Add code 'PCB' to order number. [ example: KP/PCB-8300-UDU-RB ]
- [3] Knob Handle Brake available on swivels and rigids. Add code 'KBR' to order number. [ example: KP/KBR-10300-UC-RB ]
- [4] Four Position Swivel Lock. Add code '4SL' to order number. [ example: KP/4SL-8400-DU-TB ]
- [5] Optional IH top plate [ 8-1/2" x 8-1/2" c/w 7" x 7" BHS ]. Add code 'IH' to order number. [ example: KPR/IH-6300-LAM-RB ]
- [6] \*Bolt hole pattern is slotted to 4-1/8" x 6-1/8".

# KP/KPR KINGBOLTLESS SERIES

10,000 lbs maximum capacity

## KP swivel casters and KPR rigid casters

KP Series is durable and carries heavy loads easily. Using our patented double ball kingboltless design, these casters offer unmatched performance. The durable 6-1/2" diameter swivel head is securely welded to the 1/2" top plate. The two precision machined and hardened raceways are locked together by over fifty 1/2" diameter ball bearings. The double raceways provide easier operation than single race models offered by the competition and the kingboltless design means the caster can withstand punishing towline and shockload applications. The top plate has slotted mounting holes to 4-1/8" x 6-1/8" for flexible mounting. The caster is painted with a high gloss black finish and is fitted with a threaded 45° angle grease fitting for easy maintenance. North American made for fast delivery and competitive pricing. Fully customizable upon request. Use 'KPR' instead of 'KP' in the order number, when ordering RIGID casters.



KP-6300-DU-RB

Order number	Tread width	Wheel type	Plate size	Bolt hole pattern*	Bolt size	Overall height	Swivel radius	Bearing type	Load cap.
<b>12" Ø wheels</b>									
KP-12300-DU-RB	3"	Ductile Iron	6-1/4" x 7-1/2"	4-1/2" x 6"	1/2"	15-1/2"	9-5/8"	Roller	6,000
KP-12300-VGD-RB	3"	Ductile Iron [V-Groove]	6-1/4" x 7-1/2"	4-1/2" x 6"	1/2"	15-1/2"	9-5/8"	Roller	5,000
KP-12300-UC-RB	3"	Urethane on Cast	6-1/4" x 7-1/2"	4-1/2" x 6"	1/2"	15-1/2"	9-5/8"	Roller	3,200
KP-12300-UDU-RB	3"	Urethane on Ductile Iron	6-1/4" x 7-1/2"	4-1/2" x 6"	1/2"	15-1/2"	9-5/8"	Roller	6,000
KP-12300-UDU-TB	3"	Urethane on Ductile Iron	6-1/4" x 7-1/2"	4-1/2" x 6"	1/2"	15-1/2"	9-5/8"	Tapered	9,000
KP-12400-DU-TB	4"	Ductile Iron	6-1/4" x 7-1/2"	4-1/2" x 6"	1/2"	15-1/2"	9-5/8"	Tapered	10,000
KP-12400-VGD-RB	4"	Ductile Iron [V-Groove]	6-1/4" x 7-1/2"	4-1/2" x 6"	1/2"	15-1/2"	9-5/8"	Tapered	10,000
KP-12400-UC-TB	4"	Urethane on Cast	6-1/4" x 7-1/2"	4-1/2" x 6"	1/2"	15-1/2"	9-5/8"	Tapered	5,750
KP-12400-UDU-TB	4"	Urethane on Ductile Iron	6-1/4" x 7-1/2"	4-1/2" x 6"	1/2"	15-1/2"	9-5/8"	Tapered	10,000

# IH/IHR KINGBOLTLESS SERIES

25,000 lbs maximum capacity

## IH swivel casters and IHR rigid casters

This super heavy duty caster can't be beat! Swivels feature our patented double ball kingboltless design. The IH Series offers extreme capacity and superb durability in a fully towable caster. The super-strong 7-1/2" diameter swivel head has two precision machined and hardened raceways locked together by over fifty 5/8" diameter ball bearings. With 1/2" thick top plate, formed steel legs and 1-1/4" axle, this caster is the best heavy duty caster on the market. The double raceways provide easier operation than single raceway models shockload applications. The caster is painted with a high gloss black finish and is fitted with a threaded 45° angle grease fitting for easy maintenance. North American made for fast delivery and competitive pricing. Fully customizable upon request. Use 'IHR' instead of 'IH' in the order number, when ordering RIGID casters.



IH-10400-UC-TB

Order number	Tread width	Wheel type	Plate size	Bolt hole pattern	Bolt size	Overall height	Swivel radius	Bearing type	Load cap.
<b>6" ø wheels</b>									
IH-6400-DU-TB	4"	Ductile Iron	8-1/2" x 8-1/2"	7" x 7"	5/8"	9"	5-3/8"	Tapered	17,000
IH-6400-VGD-TB	4"	Ductile Iron [V-Groove]	8-1/2" x 8-1/2"	7" x 7"	5/8"	9"	5-3/8"	Tapered	17,000
IH-6400-UC-TB	4"	Urethane on Cast	8-1/2" x 8-1/2"	7" x 7"	5/8"	9"	5-3/8"	Tapered	5,750
IH-6400-UDU-TB	4"	Urethane on Ductile Iron	8-1/2" x 8-1/2"	7" x 7"	5/8"	9"	5-3/8"	Tapered	17,000
<b>8" ø wheels</b>									
IH-8400-DU-TB	4"	Ductile Iron	8-1/2" x 8-1/2"	7" x 7"	5/8"	11"	6-9/16"	Tapered	17,000
IH-8400-VGD-TB	4"	Ductile Iron [V-Groove]	8-1/2" x 8-1/2"	7" x 7"	5/8"	11"	6-9/16"	Tapered	17,000
IH-8400-UC-TB	4"	Urethane on Cast	8-1/2" x 8-1/2"	7" x 7"	5/8"	11"	6-9/16"	Tapered	5,750
IH-8400-UDU-TB	4"	Urethane on Ductile Iron	8-1/2" x 8-1/2"	7" x 7"	5/8"	11"	6-9/16"	Tapered	17,000
<b>10" ø wheels</b>									
IH-10400-DU-TB	4"	Ductile Iron	8-1/2" x 8-1/2"	7" x 7"	5/8"	13"	7-3/8"	Tapered	17,000
IH-10400-VGD-TB	4"	Ductile Iron [V-Groove]	8-1/2" x 8-1/2"	7" x 7"	5/8"	13"	7-3/8"	Tapered	17,000
IH-10400-UC-TB	4"	Urethane on Cast	8-1/2" x 8-1/2"	7" x 7"	5/8"	13"	7-3/8"	Tapered	5,750
IH-10400-UDU-TB	4"	Urethane on Ductile Iron	8-1/2" x 8-1/2"	7" x 7"	5/8"	13"	7-3/8"	Tapered	17,000
<b>12" ø wheels</b>									
IH-12400-DU-TB	4"	Ductile Iron	8-1/2" x 8-1/2"	7" x 7"	5/8"	15"	8-9/16"	Tapered	17,000
IH-12400-VGD-TB	4"	Ductile Iron [V-Groove]	8-1/2" x 8-1/2"	7" x 7"	5/8"	15"	8-9/16"	Tapered	17,000
IH-12400-UC-TB	4"	Urethane on Cast	8-1/2" x 8-1/2"	7" x 7"	5/8"	15"	8-9/16"	Tapered	5,750
IH-12400-UDU-TB	4"	Urethane on Ductile Iron	8-1/2" x 8-1/2"	7" x 7"	5/8"	15"	8-9/16"	Tapered	17,000
<b>14" ø wheels</b>									
IH-14500-DU-TB	5"	Ductile Iron	8-1/2" x 8-1/2"	7" x 7"	5/8"	17"	10-5/8"	Tapered	25,000
IH-14500-VGD-TB	5"	Ductile Iron [V-Groove]	8-1/2" x 8-1/2"	7" x 7"	5/8"	17"	10-5/8"	Tapered	25,000
<b>16" ø wheels</b>									
IH-16500-UDU-TB	5"	Urethane on Ductile Iron	8-1/2" x 8-1/2"	7" x 7"	5/8"	19"	12-7/8"	Tapered	25,000

## Options

- [1] Use 'IHR' instead of 'IH' when ordering RIGID casters.
- [2] Poly Cam Brake available on swivels and rigids. Add code 'PCB' to order number. [example: IH/PCB-8400-UDU-TB]
- [3] Knob Handle Brake available on swivels and rigids. Add code 'KBR' to order number. [example: IH/KBR-10400-UC-TB]
- [4] Four Position Swivel Lock. Add code '4SL' to order number. [example: IH/4SL-8400-DU-TB]

# AIR FREE CASTERS

910 lbs maximum capacity

## PC swivel casters and PCR rigid casters

These casters are ideal when used for maneuvering over rough surfaces, shock situations [ i.e. delicate instruments, etc. ], or anywhere that requires smooth, quiet operation of a wheeled unit. All 6" to 12" units feature the same durable double ball raceway construction as our signature Bestway series casters with an attractive zinc plated finish. All 16" and 18" units are constructed using our patented double ball kingboltless construction for superior performance and durability. Use 'BWR' or 'PCR' in the order number, when ordering RIGID casters.



PC-8L-PNAF-BB

Order number	Tread width	Wheel type	Plate size	Bolt hole pattern*	Bolt size	Overall height	Swivel radius	Bearing type	Load cap.
<b>6" ø wheels</b>									
BW-6200-PNAF-RB	2"	Air Free	4" x 4-1/2"	2-5/8" x 3-5/8"	3/8"	7-1/2"	4-9/16"	Roller	300
<b>8" ø wheels</b>									
PC-8L-PNAF-BB	2-1/2"	Air Free	4" x 4-1/2"	2-5/8" x 3-5/8"	3/8"	9-1/2"	6-1/16"	Ball Bearing	300
<b>10" ø wheels</b>									
PC-10L-PNAF-BB	3-1/2"	Air Free	4" x 4-1/2"	2-5/8" x 3-5/8"	3/8"	12-1/8"	7-1/2"	Ball Bearing	350
<b>12" ø wheels</b>									
PC-12L-PNAF-BB	3-1/2"	Air Free	4" x 4-1/2"	2-5/8" x 3-5/8"	3/8"	14-1/2"	9-1/4"	Ball Bearing	350
<b>16" ø wheels</b>									
PC-16-PNAF-BB	4"	Air Free	4-1/2" x 6-1/4"	2-7/16" x 4-15/16"	1/2"	19"	12-9/16"	Ball Bearing	500
PC-16-PN-PBB	4"	Pneumatic	4-1/2" x 6-1/4"	2-7/16" x 4-15/16"	1/2"	19"	12-9/16"	Precision Ball	745
<b>18" ø wheels</b>									
PC-18-PN-TB	6"	Pneumatic	5-1/4" x 7-1/4"	3-3/8" x 5-1/4"	1/2"	22"	15"	Tapered	910†



PC-18-PN-TB



BW-6200-PNAF-RB

## Options

- [1] Use 'BWR' or 'PCR' instead of 'BW' or 'PC' when ordering RIGID casters.
- [2] Pedal brake available on 6" to 12" swivels and rigids. Add code 'BR' to order number. [ example: PC/BR-8L-PNAF-BB ]
- [3] Poly Cam Brake available on 16" and 18" swivels and rigids. Add code 'PCB' to order number. [ example: PC/PCB-16-PNAF-BB ]
- [4] Four Position Swivel Lock. Add code '4SL' to order number. [ example: PC/4SL-12L-PNAF-BB ]
- [5] Delrin bearing. Substitute 'DEL' for 'BB' in order number. [ example: PC-8L-PNAF-DEL ]
- [6] \*Slotted mounting holes by wheel diameter:
 

Wheel ø	Slotted bolt hole pattern
6-12" ø wheels	3" x 3"
16" ø wheels	3-3/8" x 5-1/4"
18" ø wheels	4-1/8" x 6-1/8"

Note: † Capacity is calculated at 5kph/3mph

# THE ADVANTAGE OF TWIN-WHEEL CASTERS

Is it true that two are better than one? In the case of casters the answer may be YES!

With Bestway’s revolutionary double ball kingboltless caster design, the primary limiting factor on the capacity of the caster is typically the wheel, not the caster itself. By using a twin-wheel design you are splitting the caster’s weight load between two wheels rather than placing it all on one wheel, thus increasing the overall capacity of the caster.

The other main advantage of twin-wheel casters over single wheel models is the increased mobility they provide. It is much easier to change the direction of a twin-wheel caster than a single wheel caster, with a wide tread. This is because twin-wheel casters have the advantage of “differential action” when they swivel. When you attempt to change direction with a single wheel caster you must pivot the wheel around its centre point, in effect twisting it across the floor surface. The greater the load on the caster and the wider the tread surface [contact surface between the wheel tread and the floor], the more force is required, and the greater potential for damage to the floor surface, or the wheel tread material.

When turning a twin-wheel model the caster must still pivot around its centre point. However, since there are two wheels instead of one, nothing must be twisted in place. One wheel rolls in a forward direction while the other rolls backward. Not only does this require less force, but it also affords greater protection to both the floor surface and the wheel tread.

We show two of our most commonly requested twin-wheel caster series on these pages, but we can create twin-wheel versions out of any of our Patented double ball kingboltless casters [including LS, SX and KP models]. Because we manufacture our own casters, we can create custom twin-wheel casters to match your special requirements. Like all Bestway “Made to Order” items, we offer quick delivery and without minimum order quantity.

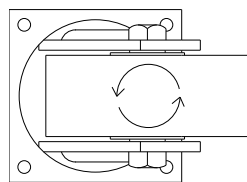

Single wheel caster turning

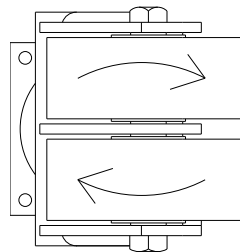

Dual wheel caster turning

# TWLE/TWLER TWIN KINGBOLTLESS SERIES

3,400 lbs maximum capacity



TWLE-6200C-UBA-PBB

## TWLE twin-wheel swivel casters and TWLER twin-wheel rigid casters

This twin-wheel version of our popular LE Series caster is ideal for applications, where maximum mobility is required. These casters offer all of the advantages of our patented double ball kingboltless design combined with the greater ease of operation afforded by twin-wheel models. Top plate has slotted mounting holes to 3-1/8" x 5-1/4" for flexible mounting. This caster is painted with a high gloss black finish and is fitted with a threaded 45° angle grease fitting for easy maintenance. Use 'TWLER' instead of 'TWLE' in the order number, when ordering RIGID casters.

Order number	Wheel type	Plate size	Bolt hole pattern*	Bolt size	Overall height	Swivel radius	Bearing type	Load cap.
<b>Dual 4" x 2" wheels</b>								
TWLE-4200-BAL-RB	Phenolic	4-1/2" x 6-1/4"	2-7/16" x 4-15/16"	1/2"	6"	3-3/4"	Roller	1,600
TWLE-4200-LAM-RB	Laminated Phenolic	4-1/2" x 6-1/4"	2-7/16" x 4-15/16"	1/2"	6"	3-3/4"	Roller	2,250
TWLE-4200-HT-RB	Hi-Temp Phenolic	4-1/2" x 6-1/4"	2-7/16" x 4-15/16"	1/2"	6"	3-3/4"	Roller	950
TWLE-4200C-DU-RB	Ductile Iron [Crowned]	4-1/2" x 6-1/4"	2-7/16" x 4-15/16"	1/2"	6"	3-3/4"	Roller	3,400
TWLE-4200-MS-RB	Machined Steel	4-1/2" x 6-1/4"	2-7/16" x 4-15/16"	1/2"	6"	3-3/4"	Roller	3,400
TWLE-4200-UN-RB	Star-Tech Urethane	4-1/2" x 6-1/4"	2-7/16" x 4-15/16"	1/2"	6"	3-3/4"	Roller	1,100
TWLE-4200-UC-RB	Urethane on Cast	4-1/2" x 6-1/4"	2-7/16" x 4-15/16"	1/2"	6"	3-3/4"	Roller	1,300
TWLE-4200C-UC-RB	Urethane on Cast [Crowned]	4-1/2" x 6-1/4"	2-7/16" x 4-15/16"	1/2"	6"	3-3/4"	Roller	1,500
TWLE-4200C-UBA-PBB	Urethane on Alum. [Crowned]	4-1/2" x 6-1/4"	2-7/16" x 4-15/16"	1/2"	6"	3-3/4"	Precision Ball	1,700
TWLE-4200C-MBA-PBB	Megabest [Crowned]	4-1/2" x 6-1/4"	2-7/16" x 4-15/16"	1/2"	6"	3-3/4"	Precision Ball	550
TWLE-4200C-ES-PBB	Solid Elastomer [Crowned]	4-1/2" x 6-1/4"	2-7/16" x 4-15/16"	1/2"	6"	3-3/4"	Precision Ball	1,500
TWLE-4200-EL-RB	Eliminator Grey Rubber	4-1/2" x 6-1/4"	2-7/16" x 4-15/16"	1/2"	6"	3-3/4"	Roller	1,100
<b>Dual 5" x 2" wheels</b>								
TWLE-5200-BAL-RB	Phenolic	4-1/2" x 6-1/4"	2-7/16" x 4-15/16"	1/2"	7"	4"	Roller	1,900
TWLE-5200-LAM-RB	Laminated Phenolic	4-1/2" x 6-1/4"	2-7/16" x 4-15/16"	1/2"	7"	4"	Roller	2,650
TWLE-5200-HT-RB	Hi-Temp Phenolic	4-1/2" x 6-1/4"	2-7/16" x 4-15/16"	1/2"	7"	4"	Roller	1,400
TWLE-5200C-DU-RB	Ductile Iron [Crowned]	4-1/2" x 6-1/4"	2-7/16" x 4-15/16"	1/2"	7"	4"	Roller	3,400
TWLE-5200-MS-RB	Machined Steel	4-1/2" x 6-1/4"	2-7/16" x 4-15/16"	1/2"	7"	4"	Roller	3,400
TWLE-5200-UN-RB	Star-Tech Urethane	4-1/2" x 6-1/4"	2-7/16" x 4-15/16"	1/2"	7"	4"	Roller	1,400
TWLE-5200-UC-RB	Urethane on Cast	4-1/2" x 6-1/4"	2-7/16" x 4-15/16"	1/2"	7"	4"	Roller	1,950
TWLE-5200C-UC-RB	Urethane on Cast [Crowned]	4-1/2" x 6-1/4"	2-7/16" x 4-15/16"	1/2"	7"	4"	Roller	1,900
TWLE-5200C-UBA-PBB	Urethane on Alum. [Crowned]	4-1/2" x 6-1/4"	2-7/16" x 4-15/16"	1/2"	7"	4"	Precision Ball	1,700
TWLE-5200C-MBA-PBB	Megabest [Crowned]	4-1/2" x 6-1/4"	2-7/16" x 4-15/16"	1/2"	7"	4"	Precision Ball	550
TWLE-5200C-ES-PBB	Solid Elastomer [Crowned]	4-1/2" x 6-1/4"	2-7/16" x 4-15/16"	1/2"	7"	4"	Precision Ball	1,900
TWLE-5200-EL-RB	Eliminator Grey Rubber	4-1/2" x 6-1/4"	2-7/16" x 4-15/16"	1/2"	7"	4"	Roller	1,300

## Options

- [1] Use 'TWLER' instead of 'TWLE' when ordering RIGID casters.
- [2] Poly Cam Brake available on swivels and rigids. Add code 'PCB' to order number. [ example: TWLE/PCB-6200-UC-RB ]
- [3] Knob Handle Brake available on swivels and rigids. Add code 'KBR' to order number. [ example: TWLER/KBR-4200-BAL-RB ]
- [4] Four Position Swivel Lock. Will increase OH. Add code '4SL' to order number. [ example: TWLE/4SL-8200C-DU-RB ]
- [5] Head seals available on swivels only. Add code 'HS' to order number. [ example: TWLE/HS-4200-EL-RB ]
- [6] Heavy duty roller bearing. Substitute 'HRB' for 'RB' in order number. [ example: TWLE-6200C-DU-HRB ]
- [7] Flanged brass bearing. Substitute 'BF' for 'RB' in order number. [ example: TWLE-6200-HT-BF ]
- [8] Flanged precision bearing. Substitute 'FLPBB' for 'RB' in order number. [ example: TWLE-4200-EL-FLPBB ]
- [9] \*Bolt hole pattern is slotted to 3-1/8" x 5-1/4".

# TWLE/TWLER TWIN KINGBOLTLESS SERIES

3,400 lbs maximum capacity

## TWLE twin-wheel swivel casters and TWLER twin-wheel rigid casters

This twin-wheel version of our popular LE Series caster is ideal for applications, where maximum mobility is required. These casters offer all of the advantages of our patented double ball kingboltless design combined with the greater ease of operation afforded by twin-wheel models. Top plate has slotted mounting holes to 3-1/8" x 5-1/4" for flexible mounting. This caster is painted with a high gloss black finish and is fitted with a threaded 45° angle grease fitting for easy maintenance. Use 'TWLER' instead of 'TWLE' in the order number, when ordering RIGID casters.



TWLER-8200-BAL-RB

Order number	Wheel type	Plate size	Bolt hole pattern*	Bolt size	Overall height	Swivel radius	Bearing type	Load cap.
<b>Dual 6" x 2" wheels</b>								
TWLE-6200-BAL-RB	Phenolic	4-1/2" x 6-1/4"	2-7/16" x 4-15/16"	1/2"	8"	5"	Roller	2,250
TWLE-6200-LAM-RB	Laminated Phenolic	4-1/2" x 6-1/4"	2-7/16" x 4-15/16"	1/2"	8"	5"	Roller	2,850
TWLE-6200-HT-RB	Hi-Temp Phenolic	4-1/2" x 6-1/4"	2-7/16" x 4-15/16"	1/2"	8"	5"	Roller	1,700
TWLE-6200C-DU-RB	Ductile Iron [Crowned]	4-1/2" x 6-1/4"	2-7/16" x 4-15/16"	1/2"	8"	5"	Roller	3,400
TWLE-6200-MS-RB	Machined Steel	4-1/2" x 6-1/4"	2-7/16" x 4-15/16"	1/2"	8"	5"	Roller	3,400
TWLE-6200-UN-RB	Star-Tech Urethane	4-1/2" x 6-1/4"	2-7/16" x 4-15/16"	1/2"	8"	5"	Roller	1,700
TWLE-6200-UC-RB	Urethane on Cast	4-1/2" x 6-1/4"	2-7/16" x 4-15/16"	1/2"	8"	5"	Roller	2,300
TWLE-6200C-UC-RB	Urethane on Cast [Crowned]	4-1/2" x 6-1/4"	2-7/16" x 4-15/16"	1/2"	8"	5"	Roller	1,950
TWLE-6200C-UBA-PBB	Urethane on Alum. [Crowned]	4-1/2" x 6-1/4"	2-7/16" x 4-15/16"	1/2"	8"	5"	Precision Ball	2,250
TWLE-6200C-MBA-PBB	Megabest [Crowned]	4-1/2" x 6-1/4"	2-7/16" x 4-15/16"	1/2"	8"	5"	Precision Ball	750
TWLE-6200-ES-PBB	Solid Elastomer	4-1/2" x 6-1/4"	2-7/16" x 4-15/16"	1/2"	8"	5"	Precision Ball	2,250
TWLE-6200C-ES-PBB	Solid Elastomer [Crowned]	4-1/2" x 6-1/4"	2-7/16" x 4-15/16"	1/2"	8"	5"	Precision Ball	2,250
TWLE-6200C-EG-PBB	Elastiglide [Crowned]	4-1/2" x 6-1/4"	2-7/16" x 4-15/16"	1/2"	8"	5"	Precision Ball	2,250
TWLE-6200-EL-RB	Eliminator Grey Rubber	4-1/2" x 6-1/4"	2-7/16" x 4-15/16"	1/2"	8"	5"	Roller	1,700
TWLE-6200C-EL-RB	Eliminator Grey Rubber [Crowned]	4-1/2" x 6-1/4"	2-7/16" x 4-15/16"	1/2"	8"	5"	Roller	1,700
<b>Dual 8" x 2" wheels</b>								
TWLE-8200-BAL-RB	Phenolic	4-1/2" x 6-1/4"	2-7/16" x 4-15/16"	1/2"	10"	6-3/4"	Roller	2,650
TWLE-8200-LAM-RB	Laminated Phenolic	4-1/2" x 6-1/4"	2-7/16" x 4-15/16"	1/2"	10"	6-3/4"	Roller	3,200
TWLE-8200-HT-RB	Hi-Temp Phenolic	4-1/2" x 6-1/4"	2-7/16" x 4-15/16"	1/2"	10"	6-3/4"	Roller	2,050
TWLE-8200C-DU-RB	Ductile Iron [Crowned]	4-1/2" x 6-1/4"	2-7/16" x 4-15/16"	1/2"	10"	6-3/4"	Roller	3,400
TWLE-8200-UN-RB	Star-Tech Urethane	4-1/2" x 6-1/4"	2-7/16" x 4-15/16"	1/2"	10"	6-3/4"	Roller	1,900
TWLE-8200-UC-RB	Urethane on Cast	4-1/2" x 6-1/4"	2-7/16" x 4-15/16"	1/2"	10"	6-3/4"	Roller	2,850
TWLE-8200C-UC-RB	Urethane on Cast [Crowned]	4-1/2" x 6-1/4"	2-7/16" x 4-15/16"	1/2"	10"	6-3/4"	Roller	2,350
TWLE-8200C-UBA-PBB	Urethane on Alum. [Crowned]	4-1/2" x 6-1/4"	2-7/16" x 4-15/16"	1/2"	10"	6-3/4"	Precision Ball	2,850
TWLE-8200C-MBA-PBB	Megabest [Crowned]	4-1/2" x 6-1/4"	2-7/16" x 4-15/16"	1/2"	10"	6-3/4"	Precision Ball	950
TWLE-8200-ES-PBB	Solid Elastomer	4-1/2" x 6-1/4"	2-7/16" x 4-15/16"	1/2"	10"	6-3/4"	Precision Ball	3,000
TWLE-8200C-ES-PBB	Solid Elastomer [Crowned]	4-1/2" x 6-1/4"	2-7/16" x 4-15/16"	1/2"	10"	6-3/4"	Precision Ball	3,000
TWLE-8200C-EG-PBB	Elastiglide [Crowned]	4-1/2" x 6-1/4"	2-7/16" x 4-15/16"	1/2"	10"	6-3/4"	Precision Ball	2,850
TWLE-8200-EL-RB	Eliminator Grey Rubber	4-1/2" x 6-1/4"	2-7/16" x 4-15/16"	1/2"	10"	6-3/4"	Roller	1,700
TWLE-8200C-EL-RB	Eliminator Grey Rubber [Crowned]	4-1/2" x 6-1/4"	2-7/16" x 4-15/16"	1/2"	10"	6-3/4"	Roller	1,700



# TWIH/TWIHR TWIN KINGBOLTLESS SERIES

25,000 lbs maximum capacity



TWIH-12400-DU-TB

## TWIH twin-wheel swivel casters and TWIHR twin-wheel rigid casters

This twin-wheel version of our proven IH Series caster combines unmatched strength, durability and mobility. Swivels use the same super high-capacity patented double ball kingboltless head as our single wheel version, combined with the greater ease of operation afforded by twin-wheel models. This caster is painted with a high gloss black finish and is fitted with a threaded 45° angle grease fitting for easy maintenance. If extremely high load capacity and great mobility are a must, then this is the caster for you. Use 'THIHR' instead of 'TWIH' in the order number, when ordering RIGID casters.

Order number	Wheel type	Plate size	Bolt hole pattern	Bolt size	Overall height	Swivel radius	Bearing type	Load cap.
<b>Dual 6" x 4" wheels</b>								
TWIH-6400-DU-TB	Ductile Iron	8-1/2" x 8-1/2"	7" x 7"	5/8"	9-1/2"	6-3/4"	Tapered	25,000
TWIH-6400-UC-TB	Urethane on Cast	8-1/2" x 8-1/2"	7" x 7"	5/8"	9-1/2"	6-3/4"	Tapered	10,900
TWIH-6400-UDU-TB	Urethane on Ductile Iron	8-1/2" x 8-1/2"	7" x 7"	5/8"	9-1/2"	6-3/4"	Tapered	25,000
<b>Dual 8" x 4" wheels</b>								
TWIH-8400-DU-TB	Ductile Iron	8-1/2" x 8-1/2"	7" x 7"	5/8"	11-1/2"	7-3/4"	Tapered	25,000
TWIH-8400-UC-TB	Urethane on Cast	8-1/2" x 8-1/2"	7" x 7"	5/8"	11-1/2"	7-3/4"	Tapered	10,900
TWIH-8400-UDU-TB	Urethane on Ductile Iron	8-1/2" x 8-1/2"	7" x 7"	5/8"	11-1/2"	7-3/4"	Tapered	25,000
<b>Dual 10" x 4" wheels</b>								
TWIH-10400-DU-TB	Ductile Iron	8-1/2" x 8-1/2"	7" x 7"	5/8"	13-1/2"	8-3/8"	Tapered	25,000
TWIH-10400-UC-TB	Urethane on Cast	8-1/2" x 8-1/2"	7" x 7"	5/8"	13-1/2"	8-3/8"	Tapered	10,900
TWIH-10400-UDU-TB	Urethane on Ductile Iron	8-1/2" x 8-1/2"	7" x 7"	5/8"	13-1/2"	8-3/8"	Tapered	25,000
<b>Dual 12" x 4" wheels</b>								
TWIH-12400-DU-TB	Ductile Iron	8-1/2" x 8-1/2"	7" x 7"	5/8"	15-1/2"	9-1/2"	Tapered	25,000
TWIH-12400-UC-TB	Urethane on Cast	8-1/2" x 8-1/2"	7" x 7"	5/8"	15-1/2"	9-1/2"	Tapered	10,900
TWIH-12400-UDU-TB	Urethane on Ductile Iron	8-1/2" x 8-1/2"	7" x 7"	5/8"	15-1/2"	9-1/2"	Tapered	25,000

## Options

- [1] Use 'TWIHR' instead of 'TWIHE' when ordering RIGID casters.
- [2] Poly Cam Brake available on swivels and rigids. Add code 'PCB' to order number. [ example: TWIH/PCB-8400-UDU-TB ]
- [3] Knob Handle Brake available on swivels and rigids. Add code 'KBR' to order number. [ example: TWIH/KBR-10400-UC-TB ]
- [4] Four Position Swivel Lock. Will increase OH. Add code '4SL' to order number. [ example: TWIH/4SL-8400-DU-TB ]



# STAINLESS STEEL CASTERS

SSLX/SSLXR series	42
SSGP/SSGPR series	43
SSBH series	45
SS/SSR series	47
SSRT/SSRTR series	49
SSLD/SSLDR series	51
SSHD/SSHDR series	53
SSLE/SSLER series	55
SSLS/SSLSR series	57

# SSLX/SSLXR SERIES STAINLESS STEEL

250 lbs maximum capacity



SSLXR-5150-NY-DEL

## SSLX swivel casters and SSLXR rigid casters

This is a 304 stainless steel version of our popular LX Series caster. Constructed in deep-dish double ball raceways, stainless balls, stainless axles, everything on this caster is stainless! Industry standard top plate, with 1-3/4" x 3" slotted mounting holes for flexible mounting. Excellent mobility and large wheel selection make this caster an excellent choice for all of your stainless applications. Ideal for hospital carts, cheese factories, slaughterhouses, poultry and fish processing plants, where steam cleaning and cleanliness are a must. Head seals are standard. Use 'SSLXR' instead of 'SSLX' in the order number, when ordering RIGID casters.

Order number	Tread width	Wheel type	Plate size	Bolt hole pattern*	Bolt size	Overall height	Swivel radius	Bearing type	Load cap.
<b>3" Ø wheels</b>									
SSLX-3125-BAL	1-1/4"	Phenolic	2-5/8" x 3-3/4"	3" x 3"	5/16"	4-1/8"	2-3/4"	Plain	250
SSLX-3125-UN-DEL	1-1/4"	Star-Tech Urethane	2-5/8" x 3-3/4"	3" x 3"	5/16"	4-1/8"	2-3/4"	Delrin	250
SSLX-3125-EL-DEL	1-1/4"	Eliminator Grey Rubber	2-5/8" x 3-3/4"	3" x 3"	5/16"	4-1/8"	2-3/4"	Delrin	200
SSLX-3125-NL	1-1/4"	Ny-Lite	2-5/8" x 3-3/4"	3" x 3"	5/16"	4-1/8"	2-3/4"	Plain	250
SSLX-3125-WNL	1-1/4"	White Poly-Olefin	2-5/8" x 3-3/4"	3" x 3"	5/16"	4-1/8"	2-3/4"	Plain	250
SSLX-3150C-ES-DEL	1-1/2"	Solid Elastomer [Crowned]	2-5/8" x 3-3/4"	3" x 3"	5/16"	4-1/8"	2-3/4"	Delrin	250
SSLX-3150-NY-DEL	1-1/2"	White Nylon	2-5/8" x 3-3/4"	3" x 3"	5/16"	4-1/8"	2-3/4"	Delrin	250
SSLX-080-UNY-SSRB	30mm	Urethane on Nylon	2-5/8" x 3-3/4"	3" x 3"	5/16"	4-1/8"	2-3/4"	Stainless Roller	220
SSLX-080-HTM-HL	35mm	Hi-Temp Monolithic	2-5/8" x 3-3/4"	3" x 3"	5/16"	4-1/8"	2-3/4"	Hi-Lex	220
<b>4" Ø wheels</b>									
SSLX-4125-BAL	1-1/4"	Phenolic	2-5/8" x 3-3/4"	3" x 3"	5/16"	5-1/8"	3-1/4"	Plain	250
SSLX-4125-UN-DEL	1-1/4"	Star-Tech Urethane	2-5/8" x 3-3/4"	3" x 3"	5/16"	5-1/8"	3-1/4"	Delrin	250
SSLX-4125-EL-DEL	1-1/4"	Eliminator Grey Rubber	2-5/8" x 3-3/4"	3" x 3"	5/16"	5-1/8"	3-1/4"	Delrin	220
SSLX-4125-NL	1-1/4"	Ny-Lite	2-5/8" x 3-3/4"	3" x 3"	5/16"	5-1/8"	3-1/4"	Plain	250
SSLX-4125-WNL	1-1/4"	White Poly-Olefin	2-5/8" x 3-3/4"	3" x 3"	5/16"	5-1/8"	3-1/4"	Plain	250
SSLX-4150-HT-SSRB	1-1/2"	Hi-Temp Phenolic	2-5/8" x 3-3/4"	3" x 3"	5/16"	5-1/8"	3-1/4"	Stainless Roller	250
SSLX-4150-UN-DEL	1-1/2"	Star-Tech Urethane	2-5/8" x 3-3/4"	3" x 3"	5/16"	5-1/8"	3-1/4"	Delrin	250
SSLX-4150C-ES-DEL	1-1/2"	Solid Elastomer [Crowned]	2-5/8" x 3-3/4"	3" x 3"	5/16"	5-1/8"	3-1/4"	Delrin	250
SSLX-4150-EL-DEL	1-1/2"	Eliminator Grey Rubber	2-5/8" x 3-3/4"	3" x 3"	5/16"	5-1/8"	3-1/4"	Delrin	250
SSLX-4150-NL-DEL	1-1/2"	Ny-Lite	2-5/8" x 3-3/4"	3" x 3"	5/16"	5-1/8"	3-1/4"	Delrin	250
SSLX-4150-NY-DEL	1-1/2"	White Nylon	2-5/8" x 3-3/4"	3" x 3"	5/16"	5-1/8"	3-1/4"	Delrin	250
SSLX-100-UNY-SSRB	30mm	Urethane on Nylon	2-5/8" x 3-3/4"	3" x 3"	5/16"	5-1/8"	3-1/4"	Stainless Roller	240
SSLX-100-HTM-HL	35mm	Hi-Temp Monolithic	2-5/8" x 3-3/4"	3" x 3"	5/16"	5-1/8"	3-1/4"	Hi-Lex	250
<b>5" Ø wheels</b>									
SSLX-5125-BAL	1-1/4"	Phenolic	2-5/8" x 3-3/4"	3" x 3"	5/16"	6-1/8"	3-3/4"	Plain	250
SSLX-5125-UN-DEL	1-1/4"	Star-Tech Urethane	2-5/8" x 3-3/4"	3" x 3"	5/16"	6-1/8"	3-3/4"	Delrin	250
SSLX-5125-EL-DEL	1-1/4"	Eliminator Grey Rubber	2-5/8" x 3-3/4"	3" x 3"	5/16"	6-1/8"	3-3/4"	Delrin	250
SSLX-5125-NL	1-1/4"	Ny-Lite	2-5/8" x 3-3/4"	3" x 3"	5/16"	6-1/8"	3-3/4"	Plain	250
SSLX-5125-WNL	1-1/4"	White Poly-Olefin	2-5/8" x 3-3/4"	3" x 3"	5/16"	6-1/8"	3-3/4"	Plain	250
SSLX-5150-UN-DEL	1-1/2"	Star-Tech Urethane	2-5/8" x 3-3/4"	3" x 3"	5/16"	6-1/8"	3-3/4"	Delrin	250
SSLX-5150C-ES-DEL	1-1/2"	Solid Elastomer [Crowned]	2-5/8" x 3-3/4"	3" x 3"	5/16"	6-1/8"	3-3/4"	Delrin	250
SSLX-5150-EL-DEL	1-1/2"	Eliminator Grey Rubber	2-5/8" x 3-3/4"	3" x 3"	5/16"	6-1/8"	3-3/4"	Delrin	250
SSLX-5150-NL-DEL	1-1/2"	Ny-Lite	2-5/8" x 3-3/4"	3" x 3"	5/16"	6-1/8"	3-3/4"	Delrin	250
SSLX-5150-NY-DEL	1-1/2"	White Nylon	2-5/8" x 3-3/4"	3" x 3"	5/16"	6-1/8"	3-3/4"	Delrin	250

## Options

- [1] Use 'SSLXR' instead of 'SSLX' when ordering RIGID casters.
- [2] For total lock brake on swivels only. Add code 'TLB' to order number. [ example: SSLX/TLB-5150-UN ]
- [3] Brass flanged bearing. Substitute 'BF' for 'DEL' in order number. [ example: SSLX-3150-NY-BF ]
- [4] Stainless steel roller bearing. Substitute 'SSRB' for 'DEL' in order number. [ example: SSLX-4150-NY-SSRB ]
- [5] \*Bolt hole pattern is slotted to 1-3/4" x 3".

**Note:** Due to the forming process, the overall top plate dimensions for rigid casters may be somewhat larger than the dimensions listed above.

# SSGP/SSGPR SERIES STAINLESS STEEL

600 lbs maximum capacity

## SSGP swivel casters and SSGPR rigid casters

This 304 stainless steel version of our popular GP Series caster is truly an excellent product. No other medium duty stainless caster can compare. Excellent performance, great durability, and the same top quality total lock brake as the standard GP Series make this an ideal caster for your steam cleaning and clean room applications. Double ball construction for maximum mobility, and a large wheel selection to suit any purpose. Top plate with 2-5/8" x 3-3/8" slotted mounting holes for flexible mounting. Use 'SSGPR' instead of 'SSGP' in the order number, when ordering RIGID casters.



SSGPR/TLB-100-UNY-SSRB

Order number	Tread width	Wheel type	Plate size	Bolt hole pattern*	Bolt size	Overall height	Swivel radius	Bearing type	Load cap.
<b>3" ø wheels</b>									
SSGP-3125-UN-DEL	1-1/4"	Star-Tech Urethane	3-3/8" x 4-1/8"	2-1/8" x 2-7/8"	5/16"	4-1/4"	3"	Delrin	250
SSGP-3125-EL-DEL	1-1/4"	Eliminator Grey Rubber	3-3/8" x 4-1/8"	2-1/8" x 2-7/8"	5/16"	4-1/4"	3"	Delrin	200
SSGP-3125-NL	1-1/4"	Ny-Lite	3-3/8" x 4-1/8"	2-1/8" x 2-7/8"	5/16"	4-1/4"	3"	Plain	275
SSGP-3125-WNL	1-1/4"	White Poly-Olefin	3-3/8" x 4-1/8"	2-1/8" x 2-7/8"	5/16"	4-1/4"	3"	Plain	275
SSGP-3150-BAL-DEL	1-1/2"	Phenolic	3-3/8" x 4-1/8"	2-1/8" x 2-7/8"	5/16"	4-1/4"	3"	Delrin	300
SSGP-3150C-ES-DEL	1-1/2"	Solid Elastomer [Crowned]	3-3/8" x 4-1/8"	2-1/8" x 2-7/8"	5/16"	4-1/4"	3"	Delrin	300
SSGP-3150-NY-DEL	1-1/2"	White Nylon	3-3/8" x 4-1/8"	2-1/8" x 2-7/8"	5/16"	4-1/4"	3"	Delrin	300
SSGP-080-UNY-SSRB	30mm	Urethane on Nylon	3-3/8" x 4-1/8"	2-1/8" x 2-7/8"	5/16"	4-1/4"	3"	Stainless Roller	220
SSGP-080-NY	30mm	White Nylon	3-3/8" x 4-1/8"	2-1/8" x 2-7/8"	5/16"	4-1/4"	3"	Plain	220
SSGP-080-HTM-HL	35mm	Hi-Temp Monolithic	3-3/8" x 4-1/8"	2-1/8" x 2-7/8"	5/16"	4-1/4"	3"	Hi-Lex	220
<b>4" ø wheels</b>									
SSGP-4125-UN-DEL	1-1/4"	Star-Tech Urethane	3-3/8" x 4-1/8"	2-1/8" x 2-7/8"	5/16"	5-1/16"	3-1/2"	Delrin	250
SSGP-4125-EL-DEL	1-1/4"	Eliminator Grey Rubber	3-3/8" x 4-1/8"	2-1/8" x 2-7/8"	5/16"	5-1/16"	3-1/2"	Delrin	220
SSGP-4125-NL	1-1/4"	Ny-Lite	3-3/8" x 4-1/8"	2-1/8" x 2-7/8"	5/16"	5-1/16"	3-1/2"	Plain	300
SSGP-4125-WNL	1-1/4"	White Poly-Olefin	3-3/8" x 4-1/8"	2-1/8" x 2-7/8"	5/16"	5-1/16"	3-1/2"	Plain	300
SSGP-4150-BAL-DEL	1-1/2"	Phenolic	3-3/8" x 4-1/8"	2-1/8" x 2-7/8"	5/16"	5-1/16"	3-1/2"	Delrin	400
SSGP-4150-HT-SSRB	1-1/2"	Hi-Temp Phenolic	3-3/8" x 4-1/8"	2-1/8" x 2-7/8"	5/16"	5-1/16"	3-1/2"	Stainless Roller	400
SSGP-4150-UN-DEL	1-1/2"	Star-Tech Urethane	3-3/8" x 4-1/8"	2-1/8" x 2-7/8"	5/16"	5-1/16"	3-1/2"	Delrin	400
SSGP-4150C-ES-DEL	1-1/2"	Solid Elastomer [Crowned]	3-3/8" x 4-1/8"	2-1/8" x 2-7/8"	5/16"	5-1/16"	3-1/2"	Delrin	400
SSGP-4150-EL-DEL	1-1/2"	Eliminator Grey Rubber	3-3/8" x 4-1/8"	2-1/8" x 2-7/8"	5/16"	5-1/16"	3-1/2"	Delrin	350
SSGP-4150-NL-DEL	1-1/2"	Ny-Lite	3-3/8" x 4-1/8"	2-1/8" x 2-7/8"	5/16"	5-1/16"	3-1/2"	Delrin	400
SSGP-4150-NY-DEL	1-1/2"	White Nylon	3-3/8" x 4-1/8"	2-1/8" x 2-7/8"	5/16"	5-1/16"	3-1/2"	Delrin	400
SSGP-100-UNY-SSRB	30mm	Urethane on Nylon	3-3/8" x 4-1/8"	2-1/8" x 2-7/8"	5/16"	5-1/16"	3-1/2"	Stainless Roller	240
SSGP-100-NY	35mm	White Nylon	3-3/8" x 4-1/8"	2-1/8" x 2-7/8"	5/16"	5-1/16"	3-1/2"	Plain	300
SSGP-100-HTM-HL	35mm	Hi-Temp Monolithic	3-3/8" x 4-1/8"	2-1/8" x 2-7/8"	5/16"	5-1/16"	3-1/2"	Hi-Lex	275

## Options

- [1] Use 'SSGPR' instead of 'SSGP' when ordering RIGID casters.
- [2] For total lock brake on swivels only add code 'TLB' to order number. [example: SSGP/TLB-5150-UN-DEL]
- [3] Optional 4" x 4-1/2" top plate available. Add code 'STP' to order number. [example: SSGP/STP-6150-BAL-DEL]
- [4] Brass flanged bearing. Substitute 'BF' for 'DEL' in order number. [example: SSGP-3150-NY-BF]
- [5] Stainless steel roller bearing. Substitute 'SSRB' for 'DEL' in order number. [example: SSGP-4150-NY-SSRB]
- [6] \*Bolt hole pattern is slotted to 2-5/8" x 3-3/8".

# SSGP/SSGPR SERIES STAINLESS STEEL

600 lbs maximum capacity

## SSGP swivel casters and SSGPR rigid casters

This 304 stainless steel version of our popular GP Series caster is truly an excellent product. No other medium duty stainless caster can compare. Excellent performance, great durability, and the same top quality total lock brake as the standard GP Series make this an ideal caster for your steam cleaning and clean room applications. Double ball construction for maximum mobility, and a large wheel selection to suit any purpose. Top plate with 2-5/8" x 3-3/8" slotted mounting holes for flexible mounting. Use 'SSGPR' instead of 'SSGP' in the order number, when ordering RIGID casters.



SSGPR-4150-EL-DEL

Order number	Tread width	Wheel type	Plate size	Bolt hole pattern*	Bolt size	Overall height	Swivel radius	Bearing type	Load cap.
<b>5" Ø wheels</b>									
SSGP-5150-BAL-DEL	1-1/2"	Phenolic	3-3/8" x 4-1/8"	2-1/8" x 2-7/8"	5/16"	6-1/8"	4-1/4"	Delrin	500
SSGP-5150-UN-DEL	1-1/2"	Star-Tech Urethane	3-3/8" x 4-1/8"	2-1/8" x 2-7/8"	5/16"	6-1/8"	4-1/4"	Delrin	500
SSGP-5150C-ES-DEL	1-1/2"	Solid Elastomer [Crowned]	3-3/8" x 4-1/8"	2-1/8" x 2-7/8"	5/16"	6-1/8"	4-1/4"	Delrin	500
SSGP-5150-EL-DEL	1-1/2"	Eliminator Grey Rubber	3-3/8" x 4-1/8"	2-1/8" x 2-7/8"	5/16"	6-1/8"	4-1/4"	Delrin	400
SSGP-5150-NL-DEL	1-1/2"	Ny-Lite	3-3/8" x 4-1/8"	2-1/8" x 2-7/8"	5/16"	6-1/8"	4-1/4"	Delrin	500
SSGP-5150-NY-DEL	1-1/2"	White Nylon	3-3/8" x 4-1/8"	2-1/8" x 2-7/8"	5/16"	6-1/8"	4-1/4"	Delrin	500
SSGP-125-UNY-SSRB	30mm	Urethane on Nylon	3-3/8" x 4-1/8"	2-1/8" x 2-7/8"	5/16"	6-1/8"	4-1/4"	Stainless Roller	400
SSGP-125-NY	40mm	White Nylon	3-3/8" x 4-1/8"	2-1/8" x 2-7/8"	5/16"	6-1/8"	4-1/4"	Plain	350
SSGP-125-HTM-HL	40mm	Hi-Temp Monolithic	3-3/8" x 4-1/8"	2-1/8" x 2-7/8"	5/16"	6-1/8"	4-1/4"	Hi-Lex	330
<b>6" Ø wheels</b>									
SSGP-6150-BAL-DEL	1-1/2"	Phenolic	3-3/8" x 4-1/8"	2-1/8" x 2-7/8"	5/16"	7-1/8"	4-3/4"	Delrin	600
SSGP-6150-UN-DEL	1-1/2"	Star-Tech Urethane	3-3/8" x 4-1/8"	2-1/8" x 2-7/8"	5/16"	7-1/8"	4-3/4"	Delrin	600
SSGP-6150-EL-DEL	1-1/2"	Eliminator Grey Rubber	3-3/8" x 4-1/8"	2-1/8" x 2-7/8"	5/16"	7-1/8"	4-3/4"	Delrin	500
SSGP-6150-NL-DEL	1-1/2"	Ny-Lite	3-3/8" x 4-1/8"	2-1/8" x 2-7/8"	5/16"	7-1/8"	4-3/4"	Delrin	600
SSGP-6150-NY-DEL	1-1/2"	White Nylon	3-3/8" x 4-1/8"	2-1/8" x 2-7/8"	5/16"	7-1/8"	4-3/4"	Delrin	600

# SSBH SERIES STAINLESS STEEL

500 lbs maximum capacity



SSBH/TLB-100-NY

## SSBH swivel casters

The SSBH Series combines the versatility of mounting options of a bolthole caster with the unbeatable environmental resistance of a fully stainless steel caster. Mount this caster with a nut and bolt or with one of the many standard or custom stainless steel stems available from our machine shop. The optional total lock brake locks both the wheel and swivel with one push of the pedal. With double ball raceway construction and all stainless steel components, this is an excellent medium duty caster. Use 'SSBHR' instead of 'SSBH' in the order number, when ordering RIGID casters.

Order number	Tread width	Wheel type	Bolt size	Overall height	Swivel radius	Bearing type	Load cap.
<b>3" ø wheels</b>							
SSBH-3125-UN-DEL	1-1/4"	Star-Tech Urethane	12.2mm	4"	3"	Delrin	250
SSBH-3125-EL-DEL	1-1/4"	Eliminator Grey Rubber	12.2mm	4"	3"	Delrin	200
SSBH-3125-NL	1-1/4"	Ny-Lite	12.2mm	4"	3"	Plain	275
SSBH-3125-WNL	1-1/4"	White Poly-Olefin	12.2mm	4"	3"	Plain	275
SSBH-3150-BAL-DEL	1-1/2"	Phenolic	12.2mm	4"	3"	Delrin	300
SSBH-3150C-ES-DEL	1-1/2"	Solid Elastomer [Crowned]	12.2mm	4"	3"	Delrin	300
SSBH-3150-NY-DEL	1-1/2"	White Nylon	12.2mm	4"	3"	Delrin	300
SSBH-080-UNY-SSRB	30mm	Urethane on Nylon	12.2mm	4"	3"	Stainless Roller	220
SSBH-080-NY	30mm	White Nylon	12.2mm	4"	3"	Plain	220
SSBH-080-HTM-HL	35mm	Hi-Temp Monolithic	12.2mm	4"	3"	Hi-Lex	220
<b>4" ø wheels</b>							
SSBH-4125-UN-DEL	1-1/4"	Star-Tech Urethane	12.2mm	4-15/16"	3-1/2"	Delrin	250
SSBH-4125-EL-DEL	1-1/4"	Eliminator Grey Rubber	12.2mm	4-15/16"	3-1/2"	Delrin	220
SSBH-4125-NL	1-1/4"	Ny-Lite	12.2mm	4-15/16"	3-1/2"	Plain	300
SSBH-4125-WNL	1-1/4"	White Poly-Olefin	12.2mm	4-15/16"	3-1/2"	Plain	300
SSBH-4150-BAL-DEL	1-1/2"	Phenolic	12.2mm	4-15/16"	3-1/2"	Delrin	350
SSBH-4150-HT-SSRB	1-1/2"	Hi-Temp Phenolic	12.2mm	4-15/16"	3-1/2"	Stainless Roller	350
SSBH-4150-UN-DEL	1-1/2"	Star-Tech Urethane	12.2mm	4-15/16"	3-1/2"	Delrin	350
SSBH-4150C-ES-DEL	1-1/2"	Solid Elastomer [Crowned]	12.2mm	4-15/16"	3-1/2"	Delrin	350
SSBH-4150-EL-DEL	1-1/2"	Eliminator Grey Rubber	12.2mm	4-15/16"	3-1/2"	Delrin	350
SSBH-4150-NL-DEL	1-1/2"	Ny-Lite	12.2mm	4-15/16"	3-1/2"	Delrin	350
SSBH-4150-NY-DEL	1-1/2"	White Nylon	12.2mm	4-15/16"	3-1/2"	Delrin	350
SSBH-100-UNY-SSRB	30mm	Urethane on Nylon	12.2mm	4-15/16"	3-1/2"	Stainless Roller	240
SSBH-100-NY	35mm	White Nylon	12.2mm	4-15/16"	3-1/2"	Plain	300
SSBH-100-HTM-HL	35mm	Hi-Temp Monolithic	12.2mm	4-15/16"	3-1/2"	Hi-Lex	275

## Options

- [1] For total lock brake add code 'TLB' to order number. [example: SSBH/TLB-5150-UN-DEL]
- [2] Brass flanged bearing. Substitute 'BF' for 'DEL' in order number. [example: SSBH-3150-NY-BF]
- [3] Stainless steel roller bearing. Substitute 'SSRB' for 'DEL' in order number. [example: SSBH-4150-NY-SSRB]
- [4] See page 68 for standard stems. Contact us for custom stem sizes.

**Notes:** Listed capacities are for casters only [without stems]. Some stems may reduce the above listed capacities. Contact us.

# SSBH SERIES STAINLESS STEEL

500 lbs maximum capacity

## SSBH swivel casters

The SSBH Series combines the versatility of mounting options of a bolthole caster with the unbeatable environmental resistance of a fully stainless steel caster. Mount this caster with a nut and bolt or with one of the many standard or custom stainless steel stems available from our machine shop. The optional total lock brake locks both the wheel and swivel with one push of the pedal. With double ball raceway construction and all stainless steel components, this is an excellent medium duty caster. Use 'SSBHR' instead of 'SSBH' in the order number, when ordering RIGID casters.



SSBH/TLB-100-NY

Order number	Tread width	Wheel type	Bolt size	Overall height	Swivel radius	Bearing type	Load cap.
<b>5" Ø wheels</b>							
SSBH-5150-BAL-DEL	1-1/2"	Phenolic	12.2mm	6"	4-1/4"	Delrin	450
SSBH-5150-UN-DEL	1-1/2"	Star-Tech Urethane	12.2mm	6"	4-1/4"	Delrin	450
SSBH-5150C-ES-DEL	1-1/2"	Solid Elastomer [Crowned]	12.2mm	6"	4-1/4"	Delrin	450
SSBH-5150-EL-DEL	1-1/2"	Eliminator Grey Rubber	12.2mm	6"	4-1/4"	Delrin	400
SSBH-5150-NL-DEL	1-1/2"	Ny-Lite	12.2mm	6"	4-1/4"	Delrin	450
SSBH-5150-NY-DEL	1-1/2"	White Nylon	12.2mm	6"	4-1/4"	Delrin	450
SSBH-125-UNY-SSRB	30mm	Urethane on Nylon	12.2mm	6"	4-1/4"	Stainless Roller	400
SSBH-125-NY	40mm	White Nylon	12.2mm	6"	4-1/4"	Plain	350
SSBH-125-HTM-HL	40mm	Hi-Temp Monolithic	12.2mm	6"	4-1/4"	Hi-Lex	330
<b>6" Ø wheels</b>							
SSBH-6150-BAL-DEL	1-1/2"	Phenolic	12.2mm	7"	4-3/4"	Delrin	500
SSBH-6150-UN-DEL	1-1/2"	Star-Tech Urethane	12.2mm	7"	4-3/4"	Delrin	500
SSBH-6150-EL-DEL	1-1/2"	Eliminator Grey Rubber	12.2mm	7"	4-3/4"	Delrin	500
SSBH-6150-NL-DEL	1-1/2"	Ny-Lite	12.2mm	7"	4-3/4"	Delrin	500
SSBH-6150-NY-DEL	1-1/2"	White Nylon	12.2mm	7"	4-3/4"	Delrin	500



# SS/SSR SERIES STAINLESS STEEL

1,000 lbs maximum capacity

## SS swivel casters and SSR rigid casters

Our SS Series casters make the difference. This caster uses the same top quality design that has made our signature Bestway series an industry leader. Our superior 5/8" nut and bolt kingpin construction with precision double ball raceways prove much more durable than riveted models. Top plate with 3" x 3" slotted bolt hole pattern. Heavy 1/4" material is used throughout for maximum strength and longevity. North American made for fast delivery and competitive pricing. Fully customizable upon request. A large selection of wheel sizes, wheel types, standard options and bearing types mean that this caster can fill virtually any role you have for it. We carry a large inventory of our stainless casters to ensure speedy delivery! Use 'SSR' instead of 'SS' in the order number, when ordering RIGID casters.



SS/BR-6200-NY-DEL

Order number	Tread width	Wheel type	Plate size	Bolt hole pattern*	Bolt size	Overall height	Swivel radius	Bearing type	Load cap.
<b>3" Ø wheels</b>									
SS-3200-BAL-DEL†	2"	Phenolic	4" x 4-1/2"	2-5/8" x 3-5/8"	3/8"	4-1/2"	2-13/16"	Delrin	700
SS-3200-NY-DEL	2"	White Nylon	4" x 4-1/2"	2-5/8" x 3-5/8"	3/8"	4-3/8"	2-3/4"	Delrin	700
<b>4" Ø wheels</b>									
SS-4200-BAL-DEL	2"	Phenolic	4" x 4-1/2"	2-5/8" x 3-5/8"	3/8"	5-5/8"	3-13/16"	Delrin	800
SS-4200-HT-SSRB	2"	Hi-Temp Phenolic	4" x 4-1/2"	2-5/8" x 3-5/8"	3/8"	5-5/8"	3-13/16"	Stainless Roller	500
SS-4200-SSMS-SSRB	2"	Stainless Steel	4" x 4-1/2"	2-5/8" x 3-5/8"	3/8"	5-5/8"	3-13/16"	Stainless Roller	900
SS-4200-UN-DEL	2"	Star-Tech Urethane	4" x 4-1/2"	2-5/8" x 3-5/8"	3/8"	5-5/8"	3-13/16"	Delrin	600
SS-4200C-UBA-PBB	2"	Urethane on Alum. [Crowned]	4" x 4-1/2"	2-5/8" x 3-5/8"	3/8"	5-5/8"	3-13/16"	Precision Ball	900
SS-4200C-MBA-PBB	2"	Megabest [Crowned]	4" x 4-1/2"	2-5/8" x 3-5/8"	3/8"	5-5/8"	3-13/16"	Precision Ball	300
SS-4200C-ES-DEL	2"	Solid Elastomer [Crowned]	4" x 4-1/2"	2-5/8" x 3-5/8"	3/8"	5-5/8"	3-13/16"	Delrin	800
SS-4200-EL-DEL	2"	Eliminator Grey Rubber	4" x 4-1/2"	2-5/8" x 3-5/8"	3/8"	5-5/8"	3-13/16"	Delrin	600
SS-4200-NL-DEL	2"	Ny-Lite	4" x 4-1/2"	2-5/8" x 3-5/8"	3/8"	5-5/8"	3-13/16"	Delrin	500
SS-4200-NY-DEL	2"	White Nylon	4" x 4-1/2"	2-5/8" x 3-5/8"	3/8"	5-5/8"	3-13/16"	Delrin	800
<b>5" Ø wheels</b>									
SS-5200-BAL-DEL	2"	Phenolic	4" x 4-1/2"	2-5/8" x 3-5/8"	3/8"	6-1/2"	4-7/16"	Delrin	900
SS-5200-HT-SSRB	2"	Hi-Temp Phenolic	4" x 4-1/2"	2-5/8" x 3-5/8"	3/8"	6-1/2"	4-7/16"	Stainless Roller	750
SS-5200-UN-DEL	2"	Star-Tech Urethane	4" x 4-1/2"	2-5/8" x 3-5/8"	3/8"	6-1/2"	4-7/16"	Delrin	750
SS-5200C-UBA-PBB	2"	Urethane on Alum. [Crowned]	4" x 4-1/2"	2-5/8" x 3-5/8"	3/8"	6-1/2"	4-7/16"	Precision Ball	900
SS-5200C-MBA-PBB	2"	Megabest [Crowned]	4" x 4-1/2"	2-5/8" x 3-5/8"	3/8"	6-1/2"	4-7/16"	Precision Ball	300
SS-5200C-ES-DEL	2"	Solid Elastomer [Crowned]	4" x 4-1/2"	2-5/8" x 3-5/8"	3/8"	6-1/2"	4-7/16"	Delrin	900
SS-5200-EL-DEL	2"	Eliminator Grey Rubber	4" x 4-1/2"	2-5/8" x 3-5/8"	3/8"	6-1/2"	4-7/16"	Delrin	700
SS-5200-NL-DEL	2"	Ny-Lite	4" x 4-1/2"	2-5/8" x 3-5/8"	3/8"	6-1/2"	4-7/16"	Delrin	650
SS-5200-NY-DEL	2"	White Nylon	4" x 4-1/2"	2-5/8" x 3-5/8"	3/8"	6-1/2"	4-7/16"	Delrin	900

† Wheel diameter: 3-1/4"

## Options

- [1] Use 'SSR' instead of 'SS' when ordering RIGID casters.
- [2] Pedal brake available on swivels and rigids. Add code 'BR' to order number. [example: SS/BR-8200-BAL-DEL]
- [3] Four Position Swivel Lock. Add code '4SL' to order number [example: SS/4SL-5200-EL-DEL]. Special order with ISO, K5 and PFI Plates.
- [4] Optional top plates available. Add code LTP, BTP, ISO, K5 or PFI to order number. [example: SSR/LTP-5200-BAL-DEL]
- [5] Flanged brass bearing. Substitute 'BF' for 'DEL' in order number. [example: SS-6200-NY-BF]
- [6] Stainless steel roller bearing. Substitute 'SSRB' for 'DEL' in order number. [example: SS-6200-NY-SSRB]
- [7] Stainless steel precision ball bearing. Substitute 'SSPBB' for 'PBB' in order number. [example: SS-8200C-EG-SSPBB]
- [8] Stainless Steel Flanged precision bearing. Substitute 'SSFLPBB' for 'DEL' in order number. [example: SS-6200-UN-SSFLPBB]
- [9] \*Bolt hole pattern is slotted to 3" x 3".

# SS/SSR SERIES STAINLESS STEEL

1,000 lbs maximum capacity

## SS swivel casters and SSR rigid casters

Our SS Series casters make the difference. This caster uses the same top quality design that has made our signature Bestway series an industry leader. Our superior 5/8" nut and bolt kingpin construction with precision double ball raceways prove much more durable than riveted models. Top plate with 3" x 3" slotted bolt hole pattern. Heavy 1/4" material is used throughout for maximum strength and longevity. North American made for fast delivery and competitive pricing. Fully customizable upon request. A large selection of wheel sizes, wheel types, standard options and bearing types mean that this caster can fill virtually any role you have for it. We carry a large inventory of our stainless casters to ensure speedy delivery! Use 'SSR' instead of 'SS' in the order number, when ordering RIGID casters.



SSR-6200-UN-DEL

Order number	Tread width	Wheel type	Plate size	Bolt hole pattern*	Bolt size	Overall height	Swivel radius	Bearing type	Load cap.
<b>6" Ø wheels</b>									
SS-6200-BAL-DEL	2"	Phenolic	4" x 4-1/2"	2-5/8" x 3-5/8"	3/8"	7-1/2"	4-9/16"	Delrin	900
SS-6200-HT-SSRB	2"	Hi-Temp Phenolic	4" x 4-1/2"	2-5/8" x 3-5/8"	3/8"	7-1/2"	4-9/16"	Stainless Roller	900
SS-6200-SSMS-SSRB	2"	Stainless Steel	4" x 4-1/2"	2-5/8" x 3-5/8"	3/8"	7-1/2"	4-9/16"	Stainless Roller	900
SS-6200-UN-DEL	2"	Star-Tech Urethane	4" x 4-1/2"	2-5/8" x 3-5/8"	3/8"	7-1/2"	4-9/16"	Delrin	900
SS-6200C-UBA-PBB	2"	Urethane on Alum. [Crowned]	4" x 4-1/2"	2-5/8" x 3-5/8"	3/8"	7-1/2"	4-9/16"	Precision Ball	900
SS-6200C-MBA-PBB	2"	Megabest [Crowned]	4" x 4-1/2"	2-5/8" x 3-5/8"	3/8"	7-1/2"	4-9/16"	Precision Ball	400
SS-6200-ES-DEL	2"	Solid Elastomer	4" x 4-1/2"	2-5/8" x 3-5/8"	3/8"	7-1/2"	4-9/16"	Delrin	900
SS-6200C-ES-DEL	2"	Solid Elastomer [Crowned]	4" x 4-1/2"	2-5/8" x 3-5/8"	3/8"	7-1/2"	4-9/16"	Delrin	900
SS-6200C-EG-PBB	2"	Elastiglide [Crowned]	4" x 4-1/2"	2-5/8" x 3-5/8"	3/8"	7-1/2"	4-9/16"	Precision Ball	900
SS-6200-EL-DEL	2"	Eliminator Grey Rubber	4" x 4-1/2"	2-5/8" x 3-5/8"	3/8"	7-1/2"	4-9/16"	Delrin	900
SS-6200C-EL-DEL	2"	Eliminator Grey Rubber [Crowned]	4" x 4-1/2"	2-5/8" x 3-5/8"	3/8"	7-1/2"	4-9/16"	Delrin	900
SS-6200-NL-DEL	2"	Ny-Lite	4" x 4-1/2"	2-5/8" x 3-5/8"	3/8"	7-1/2"	4-9/16"	Delrin	800
SS-6200-NY-DEL	2"	White Nylon	4" x 4-1/2"	2-5/8" x 3-5/8"	3/8"	7-1/2"	4-9/16"	Delrin	900
<b>8" Ø wheels</b>									
SS-8200-BAL-DEL	2"	Phenolic	4" x 4-1/2"	2-5/8" x 3-5/8"	3/8"	9-1/2"	5-7/8"	Delrin	950
SS-8200-HT-SSRB	2"	Hi-Temp Phenolic	4" x 4-1/2"	2-5/8" x 3-5/8"	3/8"	9-1/2"	5-7/8"	Stainless Roller	1,000
SS-8200-UN-DEL	2"	Star-Tech Urethane	4" x 4-1/2"	2-5/8" x 3-5/8"	3/8"	9-1/2"	5-7/8"	Delrin	950
SS-8200C-UBA-PBB	2"	Urethane on Alum. [Crowned]	4" x 4-1/2"	2-5/8" x 3-5/8"	3/8"	9-1/2"	5-7/8"	Precision Ball	1,000
SS-8200C-MBA-PBB	2"	Megabest [Crowned]	4" x 4-1/2"	2-5/8" x 3-5/8"	3/8"	9-1/2"	5-7/8"	Precision Ball	500
SS-8200-ES-DEL	2"	Solid Elastomer	4" x 4-1/2"	2-5/8" x 3-5/8"	3/8"	9-1/2"	5-7/8"	Delrin	950
SS-8200C-ES-DEL	2"	Solid Elastomer [Crowned]	4" x 4-1/2"	2-5/8" x 3-5/8"	3/8"	9-1/2"	5-7/8"	Delrin	950
SS-8200C-EG-PBB	2"	Elastiglide [Crowned]	4" x 4-1/2"	2-5/8" x 3-5/8"	3/8"	9-1/2"	5-7/8"	Precision Ball	1,000
SS-8200-EL-DEL	2"	Eliminator Grey Rubber	4" x 4-1/2"	2-5/8" x 3-5/8"	3/8"	9-1/2"	5-7/8"	Delrin	900
SS-8200C-EL-DEL	2"	Eliminator Grey Rubber [Crowned]	4" x 4-1/2"	2-5/8" x 3-5/8"	3/8"	9-1/2"	5-7/8"	Delrin	900
SS-8200-NL-DEL	2"	Ny-Lite	4" x 4-1/2"	2-5/8" x 3-5/8"	3/8"	9-1/2"	5-7/8"	Delrin	950
SS-8200-NY-DEL	2"	White Nylon	4" x 4-1/2"	2-5/8" x 3-5/8"	3/8"	9-1/2"	5-7/8"	Delrin	950

# SSRT/SSRTR SERIES STAINLESS STEEL

700 lbs maximum capacity

## SSRT swivel casters and SSRTR rigid casters

This unique caster offers both the top quality construction and performance of our SS Series with the versatility of a stem caster. Equipped with 5/8" kingpin construction, heavy 1/4" leg material and all stainless steel material, this is an exceptional product. Our wide selection of standard and custom stainless steel stems mean that this caster can be mounted in virtually any application. We offer a large variety of wheel types and sizes to suit your many needs. North American made for fast delivery and competitive pricing. Fully customizable upon request. Use 'SSRTR' instead of 'SSRT' in the order number, when ordering RIGID casters.



SSRT/BR-5200-EL-DEL  
C/W SSRT STEM 1" x 4" PS

Order number	Tread width	Wheel type	Overall height	Swivel radius	Bearing type	Load cap.
<b>3" Ø wheels</b>						
SSRT-3200-BAL-DEL*	2"	Phenolic	4-1/2"	2-13/16"	Delrin	600
SSRT-3200-NY-DEL	2"	White Nylon	4-3/8"	2-3/4"	Delrin	600
<b>4" Ø wheels</b>						
SSRT-4200-BAL-DEL	2"	Phenolic	5-5/8"	3-13/16"	Delrin	600
SSRT-4200-HT-SSRB	2"	Hi-Temp Phenolic	5-5/8"	3-13/16"	Stainless Roller	500
SSRT-4200-SSMS-SSRB	2"	Stainless Steel	5-5/8"	3-13/16"	Stainless Roller	600
SSRT-4200-UN-DEL	2"	Star-Tech Urethane	5-5/8"	3-13/16"	Delrin	600
SSRT-4200C-UBA-PBB	2"	Urethane on Alum. [Crowned]	5-5/8"	3-13/16"	Precision Ball	600
SSRT-4200C-MBA-PBB	2"	Megabest [Crowned]	5-5/8"	3-13/16"	Precision Ball	300
SSRT-4200C-ES-DEL	2"	Solid Elastomer [Crowned]	5-5/8"	3-13/16"	Delrin	600
SSRT-4200-EL-DEL	2"	Eliminator Grey Rubber	5-5/8"	3-13/16"	Delrin	600
SSRT-4200-NL-DEL	2"	Ny-Lite	5-5/8"	3-13/16"	Delrin	500
SSRT-4200-NY-DEL	2"	White Nylon	5-5/8"	3-13/16"	Delrin	600
<b>5" Ø wheels</b>						
SSRT-5200-BAL-DEL	2"	Phenolic	6-1/2"	4-7/16"	Delrin	600
SSRT-5200-HT-SSRB	2"	Hi-Temp Phenolic	6-1/2"	4-7/16"	Stainless Roller	600
SSRT-5200-UN-DEL	2"	Star-Tech Urethane	6-1/2"	4-7/16"	Delrin	600
SSRT-5200C-UBA-PBB	2"	Urethane on Alum. [Crowned]	6-1/2"	4-7/16"	Precision Ball	600
SSRT-5200C-MBA-PBB	2"	Megabest [Crowned]	6-1/2"	4-7/16"	Precision Ball	300
SSRT-5200C-ES-DEL	2"	Solid Elastomer [Crowned]	6-1/2"	4-7/16"	Delrin	600
SSRT-5200-EL-DEL	2"	Eliminator Grey Rubber	6-1/2"	4-7/16"	Delrin	600
SSRT-5200-NL-DEL	2"	Ny-Lite	6-1/2"	4-7/16"	Delrin	600
SSRT-5200-NY-DEL	2"	White Nylon	6-1/2"	4-7/16"	Delrin	600

\*Wheel diameter: 3-1/4"

Cross-section illustrates the design of the generously proportioned upper and lower ball races, which ride on 5/16" and 1/4" diameter stainless steel ball bearings respectively.

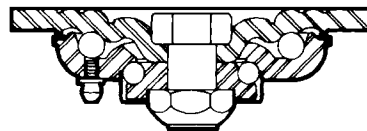

## Options

- [1] Use 'SSRTR' instead of 'SSRT' when ordering RIGID casters.
  - [2] Pedal brake available on swivels and rigids. Add code 'BR' to order number. [example: SSRT/BR-8200-BAL-DEL]
  - [3] Flanged brass bearing. Substitute 'BF' for 'DEL' in order number. [example: SSRT-6200-NY-BF]
  - [4] Stainless steel roller bearing. Substitute 'SSRB' for 'DEL' in order number. [example: SSRT-6200-NY-SSRB]
  - [5] Stainless steel precision ball bearing. Substitute 'SSPBB' for 'PBB' in order number. [example: SSRT-8200C-EG-SSPBB]
  - [6] See page 68 for standard stems. Contact us for custom stems.
  - [7] Stainless Flanged precision bearing. Substitute 'SSFLPBB' for 'DEL' in order number. [example: SSRT-4200-EL-SSFLPBB]
- Notes:** Listed capacities are for casters only [without stems]. Some stems may reduce the above listed capacities. Contact us.

# SSRT/SSRTR SERIES STAINLESS STEEL

700 lbs maximum capacity

## SSRT swivel casters and SSRTR rigid casters

This unique caster offers both the top quality construction and performance of our SS Series with the versatility of a stem caster. Equipped with 5/8" kingpin construction, heavy 1/4" leg material and all stainless steel material, this is an exceptional product. Our wide selection of standard and custom stainless steel stems mean that this caster can be mounted in virtually any application. We offer a large variety of wheel types and sizes to suit your many needs. North American made for fast delivery and competitive pricing. Fully customizable upon request. Use 'SSRTR' instead of 'SSRT' in the order number, when ordering RIGID casters.



SSRTR/BR-5200-UN-DEL  
C/W SSRT STEM 1" x 4" PS

Order number	Tread width	Wheel type	Overall height	Swivel radius	Bearing type	Load cap.
<b>6" ø wheels</b>						
SSRT-6200-BAL-DEL	2"	Phenolic	7-1/2"	4-9/16"	Delrin	600
SSRT-6200-HT-SSRB	2"	Hi-Temp Phenolic	7-1/2"	4-9/16"	Stainless Roller	600
SSRT-6200-SSMS-SSRB	2"	Stainless Steel	7-1/2"	4-9/16"	Stainless Roller	600
SSRT-6200-UN-DEL	2"	Star-Tech Urethane	7-1/2"	4-9/16"	Delrin	600
SSRT-6200C-UBA-PBB	2"	Urethane on Alum. [Crowned]	7-1/2"	4-9/16"	Precision Ball	600
SSRT-6200C-MBA-PBB	2"	Megabest [Crowned]	7-1/2"	4-9/16"	Precision Ball	400
SSRT-6200-ES-DEL	2"	Solid Elastomer	7-1/2"	4-9/16"	Delrin	600
SSRT-6200C-ES-DEL	2"	Solid Elastomer [Crowned]	7-1/2"	4-9/16"	Delrin	600
SSRT-6200C-EG-PBB	2"	Elastiglide [Crowned]	7-1/2"	4-9/16"	Precision Ball	600
SSRT-6200-EL-DEL	2"	Eliminator Grey Rubber	7-1/2"	4-9/16"	Delrin	600
SSRT-6200C-EL-DEL	2"	Eliminator Grey Rubber [Crowned]	7-1/2"	4-9/16"	Delrin	600
SSRT-6200-NL-DEL	2"	Ny-Lite	7-1/2"	4-9/16"	Delrin	600
SSRT-6200-NY-DEL	2"	White Nylon	7-1/2"	4-9/16"	Delrin	600
<b>8" ø wheels</b>						
SSRT-8200-BAL-DEL	2"	Phenolic	9-1/2"	5-7/8"	Delrin	700
SSRT-8200-HT-SSRB	2"	Hi-Temp Phenolic	9-1/2"	5-7/8"	Stainless Roller	700
SSRT-8200-UN-DEL	2"	Star-Tech Urethane	9-1/2"	5-7/8"	Delrin	700
SSRT-8200C-UBA-PBB	2"	Urethane on Alum. [Crowned]	9-1/2"	5-7/8"	Precision Ball	700
SSRT-8200C-MBA-PBB	2"	Megabest [Crowned]	9-1/2"	5-7/8"	Precision Ball	500
SSRT-8200-ES-DEL	2"	Solid Elastomer	9-1/2"	5-7/8"	Delrin	700
SSRT-8200C-ES-DEL	2"	Solid Elastomer [Crowned]	9-1/2"	5-7/8"	Delrin	700
SSRT-8200C-EG-PBB	2"	Elastiglide [Crowned]	9-1/2"	5-7/8"	Precision Ball	700
SSRT-8200-EL-DEL	2"	Eliminator Grey Rubber	9-1/2"	5-7/8"	Delrin	700
SSRT-8200C-EL-DEL	2"	Eliminator Grey Rubber [Crowned]	9-1/2"	5-7/8"	Delrin	700
SSRT-8200-NL-DEL	2"	Ny-Lite	9-1/2"	5-7/8"	Delrin	700
SSRT-8200-NY-DEL	2"	White Nylon	9-1/2"	5-7/8"	Delrin	700

# SSLD/SSLDR SERIES STAINLESS STEEL

## 1,500 lbs maximum capacity

### SSLD swivel casters and SSLDR rigid casters

Looking for the strength and durability of a kingboltless caster in a stainless steel product? Look no further. Bestway now offers a fully stainless steel version of our revolutionary LD Series patented double ball kingboltless caster. Top plate with 3" x 3" slotted bolt hole pattern. With higher capacities and greater durability than traditional kingpin models [see page 19 for full details about our breakthrough design], these casters can withstand punishing towline and shockload applications. They are ideal for applications that require a corrosive resistant, steam cleanable caster. North American made for fast delivery and competitive pricing. Fully customizable upon request. Use 'SSLDR' instead of 'SSLD' in the order number, when ordering RIGID casters.



SSLD/4SL-6200-SSMS-SSRB

Order number	Tread width	Wheel type	Plate size	Bolt hole pattern*	Bolt size	Overall height	Swivel radius	Bearing type	Load cap.
<b>3" Ø wheels</b>									
SSLD-3200-BAL-DEL†	2"	Phenolic	4" x 4-1/2"	2-5/8" x 3-5/8"	3/8"	4-5/8"	2-9/16"	Delrin	700
SSLD-3200-NY-DEL	2"	White Nylon	4" x 4-1/2"	2-5/8" x 3-5/8"	3/8"	4-1/2"	2-1/2"	Delrin	800
<b>4" Ø wheels</b>									
SSLD-4200-BAL-DEL	2"	Phenolic	4" x 4-1/2"	2-5/8" x 3-5/8"	3/8"	5-5/8"	2-11/16"	Delrin	800
SSLD-4200-LAM-DEL	2"	Laminated Phenolic	4" x 4-1/2"	2-5/8" x 3-5/8"	3/8"	5-5/8"	2-11/16"	Delrin	950▲
SSLD-4200-HT-SSRB	2"	Hi-Temp Phenolic	4" x 4-1/2"	2-5/8" x 3-5/8"	3/8"	5-5/8"	2-11/16"	Stainless Roller	500
SSLD-4200-SSMS-SSRB	2"	Stainless Steel	4" x 4-1/2"	2-5/8" x 3-5/8"	3/8"	5-5/8"	2-11/16"	Stainless Roller	1,500
SSLD-4200-UN-DEL	2"	Star-Tech Urethane	4" x 4-1/2"	2-5/8" x 3-5/8"	3/8"	5-5/8"	2-11/16"	Delrin	600
SSLD-4200C-UBA-PBB	2"	Urethane on Alum. [Crowned]	4" x 4-1/2"	2-5/8" x 3-5/8"	3/8"	5-5/8"	2-11/16"	Precision Ball	900
SSLD-4200C-MBA-PBB	2"	Megabest [Crowned]	4" x 4-1/2"	2-5/8" x 3-5/8"	3/8"	5-5/8"	2-11/16"	Precision Ball	300
SSLD-4200C-ES-DEL	2"	Solid Elastomer [Crowned]	4" x 4-1/2"	2-5/8" x 3-5/8"	3/8"	5-5/8"	2-11/16"	Delrin	800
SSLD-4200C-ES-PBB	2"	Solid Elastomer [Crowned]	4" x 4-1/2"	2-5/8" x 3-5/8"	3/8"	5-5/8"	2-11/16"	Precision Ball	800
SSLD-4200-EL-DEL	2"	Eliminator Grey Rubber	4" x 4-1/2"	2-5/8" x 3-5/8"	3/8"	5-5/8"	2-11/16"	Delrin	600
SSLD-4200-NY-DEL	2"	White Nylon	4" x 4-1/2"	2-5/8" x 3-5/8"	3/8"	5-5/8"	2-11/16"	Delrin	800
<b>5" Ø wheels</b>									
SSLD-5200-BAL-DEL	2"	Phenolic	4" x 4-1/2"	2-5/8" x 3-5/8"	3/8"	6-1/2"	3-1/2"	Delrin	950▲
SSLD-5200-LAM-DEL	2"	Laminated Phenolic	4" x 4-1/2"	2-5/8" x 3-5/8"	3/8"	6-1/2"	3-1/2"	Delrin	950▲
SSLD-5200-HT-SSRB	2"	Hi-Temp Phenolic	4" x 4-1/2"	2-5/8" x 3-5/8"	3/8"	6-1/2"	3-1/2"	Stainless Roller	750
SSLD-5200-UN-DEL	2"	Star-Tech Urethane	4" x 4-1/2"	2-5/8" x 3-5/8"	3/8"	6-1/2"	3-1/2"	Delrin	750
SSLD-5200C-UBA-PBB	2"	Urethane on Alum. [Crowned]	4" x 4-1/2"	2-5/8" x 3-5/8"	3/8"	6-1/2"	3-1/2"	Precision Ball	900
SSLD-5200C-MBA-PBB	2"	Megabest [Crowned]	4" x 4-1/2"	2-5/8" x 3-5/8"	3/8"	6-1/2"	3-1/2"	Precision Ball	300
SSLD-5200C-ES-DEL	2"	Solid Elastomer [Crowned]	4" x 4-1/2"	2-5/8" x 3-5/8"	3/8"	6-1/2"	3-1/2"	Delrin	950▲
SSLD-5200C-ES-PBB	2"	Solid Elastomer [Crowned]	4" x 4-1/2"	2-5/8" x 3-5/8"	3/8"	6-1/2"	3-1/2"	Precision Ball	1,000
SSLD-5200-EL-DEL	2"	Eliminator Grey Rubber	4" x 4-1/2"	2-5/8" x 3-5/8"	3/8"	6-1/2"	3-1/2"	Delrin	700
SSLD-5200-NY-DEL	2"	White Nylon	4" x 4-1/2"	2-5/8" x 3-5/8"	3/8"	6-1/2"	3-1/2"	Delrin	950▲

†Wheel diameter: 3-1/4"

### Options

- [1] Use 'SSLDR' instead of 'SSLD' when ordering RIGID casters.
- [2] Pedal brake available on swivels and rigid. Add code 'BR' to order number. [example: SSLD/BR-8200-BAL-DEL]
- [3] Four Position Swivel Lock. Add code '4SL' to order number [example: SSLD/4SL-5200-EL-DEL]. Special option for ISO, K5 and PFI Plates.
- [4] Optional top plates available. Add code LTP, BTP, ISO, K5 or PFI to order number. [example: SSLDR/LTP-5200-BAL-DEL]
- [5] Flanged brass bearing. Substitute 'BF' for 'DEL' in order number. [example: SSLD-6200-NY-BF]
- [6] Stainless steel roller bearing. Substitute 'SSRB' for 'DEL' in order number. [example: SSLD-6200-NY-SSRB]
- [7] Stainless steel precision ball bearing. Substitute 'SSPBB' for 'PBB' in order number. [example: SSLD-8200C-EG-SSPBB]
- [8] Stainless Flanged precision bearing. Substitute 'SSFLPBB' for 'DEL' in order number. [example: SSLD-8200-NY-SSFLPBB]
- [9] \*Bolt hole pattern is slotted to 3" x 3".

**Note:** ▲ Higher capacities can be achieved using these wheels by substituting alternate bearing types.

# SSLD/SSLDR SERIES STAINLESS STEEL

1,500 lbs maximum capacity

## SSLD swivel casters and SSLDR rigid casters

Looking for the strength and durability of a kingboltless caster in a stainless steel product? Look no further. Bestway now offers a fully stainless steel version of our revolutionary LD Series patented double ball kingboltless caster. Top plate with 3" x 3" slotted bolt hole pattern. With higher capacities and greater durability than traditional kingpin models [ see page 19 for full details about our breakthrough design ], these casters can withstand punishing towline and shockload applications. They are ideal for applications that require a corrosive resistant, steam cleanable caster. North American made for fast delivery and competitive pricing. Fully customizable upon request. Use 'SSLDR' instead of 'SSLD' in the order number, when ordering RIGID casters.



SSLD/4SL-6200-SSMS-SSRB

Order number	Tread width	Wheel type	Plate size	Bolt hole pattern*	Bolt size	Overall height	Swivel radius	Bearing type	Load cap.
<b>6" ø wheels</b>									
SSLD-6200-BAL-DEL	2"	Phenolic	4" x 4-1/2"	2-5/8" x 3-5/8"	3/8"	7-1/2"	4-1/4"	Delrin	950▲
SSLD-6200-LAM-DEL	2"	Laminated Phenolic	4" x 4-1/2"	2-5/8" x 3-5/8"	3/8"	7-1/2"	4-1/4"	Delrin	950▲
SSLD-6200-HT-SSRB	2"	Hi-Temp Phenolic	4" x 4-1/2"	2-5/8" x 3-5/8"	3/8"	7-1/2"	4-1/4"	Stainless Roller	900
SSLD-6200-SSMS-SSRB	2"	Stainless Steel	4" x 4-1/2"	2-5/8" x 3-5/8"	3/8"	7-1/2"	4-1/4"	Stainless Roller	1,500
SSLD-6200-UN-DEL	2"	Star-Tech Urethane	4" x 4-1/2"	2-5/8" x 3-5/8"	3/8"	7-1/2"	4-1/4"	Delrin	900
SSLD-6200C-UBA-PBB	2"	Urethane on Alum. [Crowned]	4" x 4-1/2"	2-5/8" x 3-5/8"	3/8"	7-1/2"	4-1/4"	Precision Ball	1,200
SSLD-6200C-MBA-PBB	2"	Megabest [Crowned]	4" x 4-1/2"	2-5/8" x 3-5/8"	3/8"	7-1/2"	4-1/4"	Precision Ball	400
SSLD-6200C-ES-DEL	2"	Solid Elastomer [Crowned]	4" x 4-1/2"	2-5/8" x 3-5/8"	3/8"	7-1/2"	4-1/4"	Delrin	950▲
SSLD-6200C-ES-PBB	2"	Solid Elastomer [Crowned]	4" x 4-1/2"	2-5/8" x 3-5/8"	3/8"	7-1/2"	4-1/4"	Precision Ball	1,200
SSLD-6200C-EG-PBB	2"	Elastiglide [Crowned]	4" x 4-1/2"	2-5/8" x 3-5/8"	3/8"	7-1/2"	4-1/4"	Precision Ball	1,200
SSLD-6200-EL-DEL	2"	Eliminator Grey Rubber	4" x 4-1/2"	2-5/8" x 3-5/8"	3/8"	7-1/2"	4-1/4"	Delrin	900
SSLD-6200C-EL-DEL	2"	Eliminator Grey Rubber [Crowned]	4" x 4-1/2"	2-5/8" x 3-5/8"	3/8"	7-1/2"	4-1/4"	Delrin	900
SSLD-6200-NY-DEL	2"	White Nylon						Delrin	950▲
<b>8" ø wheels</b>									
SSLD-8200-BAL-DEL	2"	Phenolic	4" x 4-1/2"	2-5/8" x 3-5/8"	3/8"	9-1/2"	6-1/2"	Delrin	950▲
SSLD-8200-LAM-DEL	2"	Laminated Phenolic	4" x 4-1/2"	2-5/8" x 3-5/8"	3/8"	9-1/2"	6-1/2"	Delrin	950▲
SSLD-8200-HT-SSRB	2"	Hi-Temp Phenolic	4" x 4-1/2"	2-5/8" x 3-5/8"	3/8"	9-1/2"	6-1/2"	Stainless Roller	1,100
SSLD-8200-UN-DEL	2"	Star-Tech Urethane	4" x 4-1/2"	2-5/8" x 3-5/8"	3/8"	9-1/2"	6-1/2"	Delrin	950▲
SSLD-8200C-UBA-PBB	2"	Urethane on Alum. [Crowned]	4" x 4-1/2"	2-5/8" x 3-5/8"	3/8"	9-1/2"	6-1/2"	Precision Ball	1,500
SSLD-8200C-MBA-PBB	2"	Megabest [Crowned]	4" x 4-1/2"	2-5/8" x 3-5/8"	3/8"	9-1/2"	6-1/2"	Precision Ball	500
SSLD-8200C-ES-DEL	2"	Solid Elastomer [Crowned]	4" x 4-1/2"	2-5/8" x 3-5/8"	3/8"	9-1/2"	6-1/2"	Delrin	950▲
SSLD-8200C-ES-PBB	2"	Solid Elastomer [Crowned]	4" x 4-1/2"	2-5/8" x 3-5/8"	3/8"	9-1/2"	6-1/2"	Precision Ball	1,500
SSLD-8200C-EG-PBB	2"	Elastiglide [Crowned]	4" x 4-1/2"	2-5/8" x 3-5/8"	3/8"	9-1/2"	6-1/2"	Precision Ball	1,500
SSLD-8200-EL-DEL	2"	Eliminator Grey Rubber	4" x 4-1/2"	2-5/8" x 3-5/8"	3/8"	9-1/2"	6-1/2"	Delrin	900
SSLD-8200C-EL-DEL	2"	Eliminator Grey Rubber [Crowned]	4" x 4-1/2"	2-5/8" x 3-5/8"	3/8"	9-1/2"	6-1/2"	Delrin	900
SSLD-8200-NY-DEL	2"	White Nylon	4" x 4-1/2"	2-5/8" x 3-5/8"	3/8"	9-1/2"	6-1/2"	Delrin	950▲

# SSHD/SSHDR SERIES STAINLESS STEEL

1,200 lbs maximum capacity

## SSHD swivel casters and SSHDR rigid casters

This is an even heavier duty version of our popular SS Series casters. It's improved features include; a high-capacity 3/4" nut and bolt kingpin, larger upper and lower ball raceways featuring 3/8" and 5/16" diameter ball bearings respectively, a larger [ 4-1/2" x 6-1/4" ] industry standard top plate, and reinforced legs on both swivels and rigids. Top plate with 3-3/8" x 5-1/4" slotted bolt hole pattern. Of course everything is 100% stainless steel. This product is ideal for applications where a higher capacity stainless caster is required. North American made for fast delivery and competitive pricing. Fully customizable upon request. Use 'SSHDR' instead of 'SSHD' in the order number, when ordering RIGID casters.

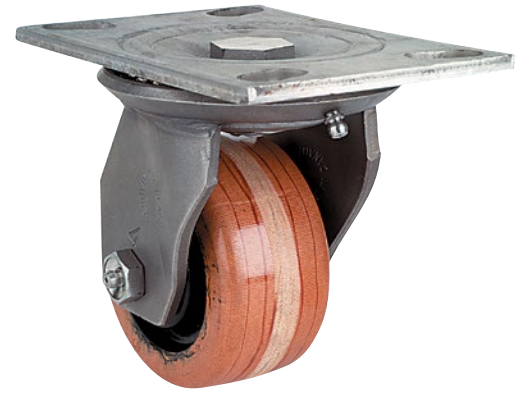

SSHD-4200-LAM-DEL

Order number	Tread width	Wheel type	Plate size	Bolt hole pattern*	Bolt size	Overall height	Swivel radius	Bearing type	Load cap.
<b>4" Ø wheels</b>									
SSHD-4200-BAL-DEL	2"	Phenolic	4-1/2" x 6-1/4"	2-7/16" x 4-15/16"	1/2"	5-5/8"	3-5/16"	Delrin	800
SSHD-4200-LAM-DEL	2"	Laminated Phenolic	4-1/2" x 6-1/4"	2-7/16" x 4-15/16"	1/2"	5-5/8"	3-5/16"	Delrin	950▲
SSHD-4200-HT-SSRB	2"	Hi-Temp Phenolic	4-1/2" x 6-1/4"	2-7/16" x 4-15/16"	1/2"	5-5/8"	3-5/16"	Stainless Roller	500
SSHD-4200-SSMS-SSRB	2"	Stainless Steel	4-1/2" x 6-1/4"	2-7/16" x 4-15/16"	1/2"	5-5/8"	3-5/16"	Stainless Roller	1,000
SSHD-4200-UN-DEL	2"	Star-Tech Urethane	4-1/2" x 6-1/4"	2-7/16" x 4-15/16"	1/2"	5-5/8"	3-5/16"	Delrin	600
SSHD-4200C-ES-DEL	2"	Solid Elastomer [Crowned]	4-1/2" x 6-1/4"	2-7/16" x 4-15/16"	1/2"	5-5/8"	3-5/16"	Delrin	800
SSHD-4200-EL-DEL	2"	Eliminator Grey Rubber	4-1/2" x 6-1/4"	2-7/16" x 4-15/16"	1/2"	5-5/8"	3-5/16"	Delrin	600
SSHD-4200-NL-DEL	2"	Ny-Lite	4-1/2" x 6-1/4"	2-7/16" x 4-15/16"	1/2"	5-5/8"	3-5/16"	Delrin	500
SSHD-4200-NY-DEL	2"	White Nylon	4-1/2" x 6-1/4"	2-7/16" x 4-15/16"	1/2"	5-5/8"	3-5/16"	Delrin	800
<b>5" Ø wheels</b>									
SSHD-5200-BAL-DEL	2"	Phenolic	4-1/2" x 6-1/4"	2-7/16" x 4-15/16"	1/2"	6-1/2"	3-3/4"	Delrin	950▲
SSHD-5200-LAM-DEL	2"	Laminated Phenolic	4-1/2" x 6-1/4"	2-7/16" x 4-15/16"	1/2"	6-1/2"	3-3/4"	Delrin	950▲
SSHD-5200-HT-SSRB	2"	Hi-Temp Phenolic	4-1/2" x 6-1/4"	2-7/16" x 4-15/16"	1/2"	6-1/2"	3-3/4"	Stainless Roller	750
SSHD-5200-UN-DEL	2"	Star-Tech Urethane	4-1/2" x 6-1/4"	2-7/16" x 4-15/16"	1/2"	6-1/2"	3-3/4"	Delrin	750
SSHD-5200C-ES-DEL	2"	Solid Elastomer [Crowned]	4-1/2" x 6-1/4"	2-7/16" x 4-15/16"	1/2"	6-1/2"	3-3/4"	Delrin	950▲
SSHD-5200-EL-DEL	2"	Eliminator Grey Rubber	4-1/2" x 6-1/4"	2-7/16" x 4-15/16"	1/2"	6-1/2"	3-3/4"	Delrin	700
SSHD-5200-NL-DEL	2"	Ny-Lite	4-1/2" x 6-1/4"	2-7/16" x 4-15/16"	1/2"	6-1/2"	3-3/4"	Delrin	650
SSHD-5200-NY-DEL	2"	White Nylon	4-1/2" x 6-1/4"	2-7/16" x 4-15/16"	1/2"	6-1/2"	3-3/4"	Delrin	950▲

## Options

- [1] Use 'SSHDR' instead of 'SSHD' when ordering RIGID casters.
- [2] Pedal brake available on swivels and rigids. Add code 'BR' to order number. [ example: SSHD/BR-8200-BAL-DEL ]
- [3] Four Position Swivel Lock. Add code '4SL' to order number. [ example: SSHD/4SL-5200-EL-DEL ]
- [4] Flanged brass bearing. Substitute 'BF' for 'DEL' in order number. [ example: SSHD-6200-NY-BF ]
- [5] Stainless steel roller bearing. Substitute 'SSRB' for 'DEL' in order number. [ example: SSHD-6200-NY-SSRB ]
- [6] Stainless Flanged precision bearing. Substitute 'SSFLPBB' for 'DEL' in order number. [ example: SSHD-8200-EL-SSFLPBB ]
- [7] \*Bolt hole pattern is slotted to 3-3/8" x 5-1/4".

Note: ▲ Higher capacities can be achieved using these wheels by substituting alternate bearing types.

# SSHD/SSHDR SERIES STAINLESS STEEL

1,200 lbs maximum capacity

## SSHD swivel casters and SSHDR rigid casters

This is an even heavier duty version of our popular SS Series casters. It's improved features include; a high-capacity 3/4" nut and bolt kingpin, larger upper and lower ball raceways featuring 3/8" and 5/16" diameter ball bearings respectively, a larger [4-1/2" x 6-1/4"] industry standard top plate, and reinforced legs on both swivels and rigids. Top plate with 3-3/8" x 5-1/4" slotted bolt hole pattern. Of course everything is 100% stainless steel. This product is ideal for applications where a higher capacity stainless caster is required. North American made for fast delivery and competitive pricing. Fully customizable upon request. Use 'SSHDR' instead of 'SSHD' in the order number, when ordering RIGID casters.

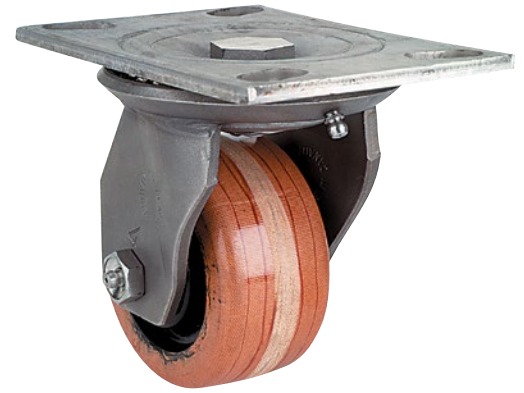

SSHD-4200-LAM-DEL

Order number	Tread width	Wheel type	Plate size	Bolt hole pattern*	Bolt size	Overall height	Swivel radius	Bearing type	Load cap.
<b>6" Ø wheels</b>									
SSHD-6200-BAL-DEL	2"	Phenolic	4-1/2" x 6-1/4"	2-7/16" x 4-15/16"	1/2"	7-1/2"	4-5/8"	Delrin	950▲
SSHD-6200-LAM-DEL	2"	Laminated Phenolic	4-1/2" x 6-1/4"	2-7/16" x 4-15/16"	1/2"	7-1/2"	4-5/8"	Delrin	950▲
SSHD-6200-HT-SSRB	2"	Hi-Temp Phenolic	4-1/2" x 6-1/4"	2-7/16" x 4-15/16"	1/2"	7-1/2"	4-5/8"	Stainless Roller	900
SSHD-6200-SSMS-SSRB	2"	Stainless Steel	4-1/2" x 6-1/4"	2-7/16" x 4-15/16"	1/2"	7-1/2"	4-5/8"	Stainless Roller	1,200
SSHD-6200-UN-DEL	2"	Star-Tech Urethane	4-1/2" x 6-1/4"	2-7/16" x 4-15/16"	1/2"	7-1/2"	4-5/8"	Delrin	900
SSHD-6200C-ES-DEL	2"	Solid Elastomer [Crowned]	4-1/2" x 6-1/4"	2-7/16" x 4-15/16"	1/2"	7-1/2"	4-5/8"	Delrin	950▲
SSHD-6200-EL-DEL	2"	Eliminator Grey Rubber	4-1/2" x 6-1/4"	2-7/16" x 4-15/16"	1/2"	7-1/2"	4-5/8"	Delrin	900
SSHD-6200C-EL-DEL	2"	Eliminator Grey Rubber [Crowned]	4-1/2" x 6-1/4"	2-7/16" x 4-15/16"	1/2"	7-1/2"	4-5/8"	Delrin	900
SSHD-6200-NL-DEL	2"	Ny-Lite	4-1/2" x 6-1/4"	2-7/16" x 4-15/16"	1/2"	7-1/2"	4-5/8"	Delrin	800
SSHD-6200-NY-DEL	2"	White Nylon	4-1/2" x 6-1/4"	2-7/16" x 4-15/16"	1/2"	7-1/2"	4-5/8"	Delrin	950▲
<b>8" Ø wheels</b>									
SSHD-8200-BAL-DEL	2"	Phenolic	4-1/2" x 6-1/4"	2-7/16" x 4-15/16"	1/2"	9-1/2"	6-3/8"	Delrin	950▲
SSHD-8200-LAM-DEL	2"	Laminated Phenolic	4-1/2" x 6-1/4"	2-7/16" x 4-15/16"	1/2"	9-1/2"	6-3/8"	Delrin	950▲
SSHD-8200-HT-SSRB	2"	Hi-Temp Phenolic	4-1/2" x 6-1/4"	2-7/16" x 4-15/16"	1/2"	9-1/2"	6-3/8"	Stainless Roller	1,100
SSHD-8200-UN-DEL	2"	Star-Tech Urethane	4-1/2" x 6-1/4"	2-7/16" x 4-15/16"	1/2"	9-1/2"	6-3/8"	Delrin	950▲
SSHD-8200C-ES-DEL	2"	Solid Elastomer [Crowned]	4-1/2" x 6-1/4"	2-7/16" x 4-15/16"	1/2"	9-1/2"	6-3/8"	Delrin	950▲
SSHD-8200-EL-DEL	2"	Eliminator Grey Rubber	4-1/2" x 6-1/4"	2-7/16" x 4-15/16"	1/2"	9-1/2"	6-3/8"	Delrin	900
SSHD-8200C-EL-DEL	2"	Eliminator Grey Rubber [Crowned]	4-1/2" x 6-1/4"	2-7/16" x 4-15/16"	1/2"	9-1/2"	6-3/8"	Delrin	900
SSHD-8200-NL-DEL	2"	Ny-Lite	4-1/2" x 6-1/4"	2-7/16" x 4-15/16"	1/2"	9-1/2"	6-3/8"	Delrin	950▲
SSHD-8200-NY-DEL	2"	White Nylon	4-1/2" x 6-1/4"	2-7/16" x 4-15/16"	1/2"	9-1/2"	6-3/8"	Delrin	950▲



# SSLE/SSLER SERIES STAINLESS STEEL

1,800 lbs maximum capacity



SSLE-6200C-ES-PBB

## SSLE swivel casters and SSLER rigid casters

A fully stainless steel version of our LE Series patented double ball kingboltless caster. The same features as our regular LE Series make this the best stainless steel caster available for a wheel with a 2" wide tread. Top plate with 3-3/8" x 5-1/4" slotted bolt hole pattern. Unmatched strength and durability, North American quality, and large wheel selection make this the choice for those high-performance applications that require a corrosive resistant, steam cleanable caster. Since there is no kingpin to bend or break, this caster is ideal for towline and shockload applications. Use 'SSLER' instead of 'SSLE' in the order number, when ordering RIGID casters.

Order number	Tread width	Wheel type	Plate size	Bolt hole pattern*	Bolt size	Overall height	Swivel radius	Bearing type	Load cap.
<b>4" ø wheels</b>									
SSLE-4200-BAL-DEL	2"	Phenolic	4-1/2" x 6-1/4"	2-7/16" x 4-15/16"	1/2"	5-5/8"	3-3/8"	Delrin	800
SSLE-4200-LAM-DEL	2"	Laminated Phenolic	4-1/2" x 6-1/4"	2-7/16" x 4-15/16"	1/2"	5-5/8"	3-3/8"	Delrin	950▲
SSLE-4200-HT-SSRB	2"	Hi-Temp Phenolic	4-1/2" x 6-1/4"	2-7/16" x 4-15/16"	1/2"	5-5/8"	3-3/8"	Stainless Roller	500
SSLE-4200-SSMS-SSRB	2"	Stainless Steel	4-1/2" x 6-1/4"	2-7/16" x 4-15/16"	1/2"	5-5/8"	3-3/8"	Stainless Roller	1,500
SSLE-4200-UN-DEL	2"	Star-Tech Urethane	4-1/2" x 6-1/4"	2-7/16" x 4-15/16"	1/2"	5-5/8"	3-3/8"	Delrin	600
SSLE-4200C-UBA-PBB	2"	Urethane on Alum. [Crowned]	4-1/2" x 6-1/4"	2-7/16" x 4-15/16"	1/2"	5-5/8"	3-3/8"	Precision Ball	900
SSLE-4200C-MBA-PBB	2"	Megabest [Crowned]	4-1/2" x 6-1/4"	2-7/16" x 4-15/16"	1/2"	5-5/8"	3-3/8"	Precision Ball	300
SSLE-4200C-ES-DEL	2"	Solid Elastomer [Crowned]	4-1/2" x 6-1/4"	2-7/16" x 4-15/16"	1/2"	5-5/8"	3-3/8"	Delrin	800
SSLE-4200C-ES-PBB	2"	Solid Elastomer [Crowned]	4-1/2" x 6-1/4"	2-7/16" x 4-15/16"	1/2"	5-5/8"	3-3/8"	Precision Ball	800
SSLE-4200-EL-DEL	2"	Eliminator Grey Rubber	4-1/2" x 6-1/4"	2-7/16" x 4-15/16"	1/2"	5-5/8"	3-3/8"	Delrin	600
SSLE-4200-NY-DEL	2"	White Nylon	4-1/2" x 6-1/4"	2-7/16" x 4-15/16"	1/2"	5-5/8"	3-3/8"	Delrin	800
<b>5" ø wheels</b>									
SSLE-5200-BAL-DEL	2"	Phenolic	4-1/2" x 6-1/4"	2-7/16" x 4-15/16"	1/2"	6-1/2"	4"	Delrin	950▲
SSLE-5200-LAM-DEL	2"	Laminated Phenolic	4-1/2" x 6-1/4"	2-7/16" x 4-15/16"	1/2"	6-1/2"	4"	Delrin	950▲
SSLE-5200-HT-SSRB	2"	Hi-Temp Phenolic	4-1/2" x 6-1/4"	2-7/16" x 4-15/16"	1/2"	6-1/2"	4"	Stainless Roller	750
SSLE-5200-UN-DEL	2"	Star-Tech Urethane	4-1/2" x 6-1/4"	2-7/16" x 4-15/16"	1/2"	6-1/2"	4"	Delrin	750
SSLE-5200C-UBA-PBB	2"	Urethane on Alum. [Crowned]	4-1/2" x 6-1/4"	2-7/16" x 4-15/16"	1/2"	6-1/2"	4"	Precision Ball	900
SSLE-5200C-MBA-PBB	2"	Megabest [Crowned]	4-1/2" x 6-1/4"	2-7/16" x 4-15/16"	1/2"	6-1/2"	4"	Precision Ball	300
SSLE-5200C-ES-DEL	2"	Solid Elastomer [Crowned]	4-1/2" x 6-1/4"	2-7/16" x 4-15/16"	1/2"	6-1/2"	4"	Delrin	950▲
SSLE-5200C-ES-PBB	2"	Solid Elastomer [Crowned]	4-1/2" x 6-1/4"	2-7/16" x 4-15/16"	1/2"	6-1/2"	4"	Precision Ball	1,000
SSLE-5200-EL-DEL	2"	Eliminator Grey Rubber	4-1/2" x 6-1/4"	2-7/16" x 4-15/16"	1/2"	6-1/2"	4"	Delrin	700
SSLE-5200-NY-DEL	2"	White Nylon	4-1/2" x 6-1/4"	2-7/16" x 4-15/16"	1/2"	6-1/2"	4"	Delrin	950▲

## Options

- [1] Use 'SSLER' instead of 'SSLE' when ordering RIGID casters.
- [2] Pedal brake available on swivels and rigids. Add code 'BR' to order number. [example: SSLE/BR-8200-BAL-DEL]
- [3] Four Position Swivel Lock. Add code '4SL' to order number. [example: SSLE/4SL-5200-EL-DEL]
- [4] Flanged brass bearing. Substitute 'BF' for 'DEL' in order number. [example: SSLE-6200-NY-BF]
- [5] Stainless steel roller bearing. Substitute 'SSRB' for 'DEL' in order number. [example: SSLE-6200-NY-SSRB]
- [6] Stainless steel precision ball bearing. Substitute 'SSPBB' for 'PBB' in order number. [example: SSLE-8200C-ES-SSPBB]
- [7] Stainless Flanged precision bearing. Substitute 'SSFLPBB' for 'DEL' in order number. [example: SSLE-8200-LAM-SSFLPBB]
- [8] \*Bolt hole pattern is slotted to 3-3/8" x 5-1/4".

**Note:** ▲ Higher capacities can be achieved using these wheels by substituting alternate bearing types.

# SSLE/SSLER SERIES STAINLESS STEEL

1,800 lbs maximum capacity



SSLE-6200C-ES-PBB

## SSLE swivel casters and SSLER rigid casters

A fully stainless steel version of our LE Series patented double ball kingboltless caster. The same features as our regular LE Series make this the best stainless steel caster available for a wheel with a 2" wide tread. Top plate with 3-3/8" x 5-1/4" slotted bolt hole pattern. Unmatched strength and durability, North American quality, and large wheel selection make this the choice for those high-performance applications that require a corrosive resistant, steam cleanable caster. Since there is no kingpin to bend or break, this caster is ideal for towline and shockload applications. Use 'SSLER' instead of 'SSLE' in the order number, when ordering RIGID casters.

Order number	Tread width	Wheel type	Plate size	Bolt hole pattern*	Bolt size	Overall height	Swivel radius	Bearing type	Load cap.
<b>6" ø wheels</b>									
SSLE-6200-BAL-DEL	2"	Phenolic	4-1/2" x 6-1/4"	2-7/16" x 4-15/16"	1/2"	7-1/2"	4-3/8"	Delrin	950▲
SSLE-6200-LAM-DEL	2"	Laminated Phenolic	4-1/2" x 6-1/4"	2-7/16" x 4-15/16"	1/2"	7-1/2"	4-3/8"	Delrin	950▲
SSLE-6200-HT-SSRB	2"	Hi-Temp Phenolic	4-1/2" x 6-1/4"	2-7/16" x 4-15/16"	1/2"	7-1/2"	4-3/8"	Stainless Roller	900
SSLE-6200-SSMS-SSRB	2"	Stainless Steel	4-1/2" x 6-1/4"	2-7/16" x 4-15/16"	1/2"	7-1/2"	4-3/8"	Stainless Roller	1,800
SSLE-6200-UN-DEL	2"	Star-Tech Urethane	4-1/2" x 6-1/4"	2-7/16" x 4-15/16"	1/2"	7-1/2"	4-3/8"	Delrin	900
SSLE-6200C-UBA-PBB	2"	Urethane on Alum. [Crowned]	4-1/2" x 6-1/4"	2-7/16" x 4-15/16"	1/2"	7-1/2"	4-3/8"	Precision Ball	1,200
SSLE-6200C-MBA-PBB	2"	Megabest [Crowned]	4-1/2" x 6-1/4"	2-7/16" x 4-15/16"	1/2"	7-1/2"	4-3/8"	Precision Ball	400
SSLE-6200C-ES-DEL	2"	Solid Elastomer [Crowned]	4-1/2" x 6-1/4"	2-7/16" x 4-15/16"	1/2"	7-1/2"	4-3/8"	Delrin	950▲
SSLE-6200C-ES-PBB	2"	Solid Elastomer [Crowned]	4-1/2" x 6-1/4"	2-7/16" x 4-15/16"	1/2"	7-1/2"	4-3/8"	Precision Ball	1,200
SSLE-6200C-EG-PBB	2"	Elastiglide [Crowned]	4-1/2" x 6-1/4"	2-7/16" x 4-15/16"	1/2"	7-1/2"	4-3/8"	Precision Ball	1,200
SSLE-6200-EL-DEL	2"	Eliminator Grey Rubber	4-1/2" x 6-1/4"	2-7/16" x 4-15/16"	1/2"	7-1/2"	4-3/8"	Delrin	900
SSLE-6200-NY-DEL	2"	White Nylon	4-1/2" x 6-1/4"	2-7/16" x 4-15/16"	1/2"	7-1/2"	4-3/8"	Delrin	950▲
<b>8" ø wheels</b>									
SSLE-8200-BAL-DEL	2"	Phenolic	4-1/2" x 6-1/4"	2-7/16" x 4-15/16"	1/2"	9-1/2"	5-11/16"	Delrin	950▲
SSLE-8200-LAM-DEL	2"	Laminated Phenolic	4-1/2" x 6-1/4"	2-7/16" x 4-15/16"	1/2"	9-1/2"	5-11/16"	Delrin	950▲
SSLE-8200-HT-SSRB	2"	Hi-Temp Phenolic	4-1/2" x 6-1/4"	2-7/16" x 4-15/16"	1/2"	9-1/2"	5-11/16"	Stainless Roller	1,100
SSLE-8200-UN-DEL	2"	Star-Tech Urethane	4-1/2" x 6-1/4"	2-7/16" x 4-15/16"	1/2"	9-1/2"	5-11/16"	Delrin	950▲
SSLE-8200C-UBA-PBB	2"	Urethane on Alum. [Crowned]	4-1/2" x 6-1/4"	2-7/16" x 4-15/16"	1/2"	9-1/2"	5-11/16"	Precision Ball	1,500
SSLE-8200C-MBA-PBB	2"	Megabest [Crowned]	4-1/2" x 6-1/4"	2-7/16" x 4-15/16"	1/2"	9-1/2"	5-11/16"	Precision Ball	500
SSLE-8200C-ES-DEL	2"	Solid Elastomer [Crowned]	4-1/2" x 6-1/4"	2-7/16" x 4-15/16"	1/2"	9-1/2"	5-11/16"	Delrin	950▲
SSLE-8200C-ES-PBB	2"	Solid Elastomer [Crowned]	4-1/2" x 6-1/4"	2-7/16" x 4-15/16"	1/2"	9-1/2"	5-11/16"	Precision Ball	1,600
SSLE-8200C-EG-PBB	2"	Elastiglide [Crowned]	4-1/2" x 6-1/4"	2-7/16" x 4-15/16"	1/2"	9-1/2"	5-11/16"	Precision Ball	1,500
SSLE-8200-EL-DEL	2"	Eliminator Grey Rubber	4-1/2" x 6-1/4"	2-7/16" x 4-15/16"	1/2"	9-1/2"	5-11/16"	Delrin	900
SSLE-8200-NY-DEL	2"	White Nylon	4-1/2" x 6-1/4"	2-7/16" x 4-15/16"	1/2"	9-1/2"	5-11/16"	Delrin	950▲

# SSLS/SSLRSR SERIES STAINLESS STEEL

3,500 lbs maximum capacity

## SSLS swivel casters and SSLRSR rigid casters

You simply won't find a caster anywhere to compare to. It is a fully 304 stainless steel solution for your high capacity, rough usage applications which require a corrosive resistant, steam cleanable caster. Using the same patented double ball kingboltless technology as our standard LS Series caster, this heavy duty stainless caster can stand up to punishing towline and shockload applications because of it's 5/16" thick legs and it's double weld. Top plate with 3-3/8" x 5-1/4" slotted bolt hole pattern. North American made for fast delivery and competitive pricing. Fully customizable upon request. Use 'SSLRSR' instead of 'SSLS' in the order number, when ordering RIGID casters.



SSLRSR-8300-LAM-DEL

Order number	Tread width	Wheel type	Plate size	Bolt hole pattern*	Bolt size	Overall height	Swivel radius	Bearing type	Load cap.
<b>6" Ø wheels</b>									
SSLS-6250L-BAL-DEL	2-1/2"	Phenolic	4-1/2" x 6-1/4"	2-7/16" x 4-15/16"	1/2"	7-1/2"	5-1/2"	Delrin	1,600
SSLS-6250SC-ES-PBB	2-1/2"	Solid Elastomer [Crowned]	4-1/2" x 6-1/4"	2-7/16" x 4-15/16"	1/2"	7-1/2"	5-1/2"	Precision Ball	1,500
SSLS-6300-BAL-DEL	3"	Phenolic	4-1/2" x 6-1/4"	2-7/16" x 4-15/16"	1/2"	7-1/2"	5-1/2"	Delrin	2,000
SSLS-6300-LAM-DEL	3"	Laminated Phenolic	4-1/2" x 6-1/4"	2-7/16" x 4-15/16"	1/2"	7-1/2"	5-1/2"	Delrin	2,500
SSLS-6300C-UBA-PBB	3"	Urethane on Alum. [Crowned]	4-1/2" x 6-1/4"	2-7/16" x 4-15/16"	1/2"	7-1/2"	5-1/2"	Precision Ball	2,100
SSLS-6300-MBA-PBB	3"	Megabest	4-1/2" x 6-1/4"	2-7/16" x 4-15/16"	1/2"	7-1/2"	5-1/2"	Precision Ball	700
<b>8" Ø wheels</b>									
SSLS-8250L-BAL-DEL	2-1/2"	Phenolic	4-1/2" x 6-1/4"	2-7/16" x 4-15/16"	1/2"	10-1/8"	6-1/2"	Delrin	2,000
SSLS-8250SC-ES-PBB	2-1/2"	Solid Elastomer [Crowned]	4-1/2" x 6-1/4"	2-7/16" x 4-15/16"	1/2"	10-1/8"	6-1/2"	Precision Ball	2,000
SSLS-8300-BAL-DEL	3"	Phenolic	4-1/2" x 6-1/4"	2-7/16" x 4-15/16"	1/2"	10-1/8"	6-1/2"	Delrin	2,500
SSLS-8300-LAM-DEL	3"	Laminated Phenolic	4-1/2" x 6-1/4"	2-7/16" x 4-15/16"	1/2"	10-1/8"	6-1/2"	Delrin	3,100
SSLS-8300C-UBA-PBB	3"	Urethane on Alum. [Crowned]	4-1/2" x 6-1/4"	2-7/16" x 4-15/16"	1/2"	10-1/8"	6-1/2"	Precision Ball	2,550
SSLS-8300-MBA-PBB	3"	Megabest	4-1/2" x 6-1/4"	2-7/16" x 4-15/16"	1/2"	10-1/8"	6-1/2"	Precision Ball	850
<b>10" Ø wheels</b>									
SSLS-10250L-BAL-DEL	2-1/2"	Phenolic	4-1/2" x 6-1/4"	2-7/16" x 4-15/16"	1/2"	11-1/2"	7-3/4"	Delrin	2,400
SSLS-10250SC-UBA-PBB	2-1/2"	Urethane on Alum. [Crowned]	4-1/2" x 6-1/4"	2-7/16" x 4-15/16"	1/2"	11-1/2"	7-3/4"	Precision Ball	3,000
SSLS-10250SC-MBA-PBB	2-1/2"	Megabest [Crowned]	4-1/2" x 6-1/4"	2-7/16" x 4-15/16"	1/2"	11-1/2"	7-3/4"	Precision Ball	1,000
SSLS-10250SC-ES-PBB	2-1/2"	Solid Elastomer [Crowned]	4-1/2" x 6-1/4"	2-7/16" x 4-15/16"	1/2"	11-1/2"	7-3/4"	Precision Ball	2,200
SSLS-10300-BAL-DEL	3"	Phenolic	4-1/2" x 6-1/4"	2-7/16" x 4-15/16"	1/2"	11-1/2"	7-3/4"	Delrin	2,500
<b>12" Ø wheels</b>									
SSLS-12300-BAL-DEL	3"	Phenolic	4-1/2" x 6-1/4"	2-7/16" x 4-15/16"	1/2"	13-1/2"	9"	Delrin	3,500

## Options

- [1] Use 'SSLRSR' instead of 'SSLS' when ordering RIGID casters.
- [2] Knob Handle Brake available on swivels and rigids. Add code 'KBR' to order number. [example: SSLS/KBR-8300-BAL-DEL]
- [3] Poly Cam Brake available on swivels and rigids. Add code 'PCB' to order number. [example: SSLS/PCB-6300-UN-DEL]
- [4] Four Position Swivel Lock. Add code '4SL' to order number. [example: SSLS/4SL-10250SC-UBA-PBB]
- [5] Flanged brass bearing. Substitute 'BF' for 'DEL' in order number. [example: SSLS-6300-LAM-BF]
- [6] Stainless steel roller bearing. Substitute 'SSRB' for 'DEL' in order number. [example: SSLS-6300-UN-SSRB]
- [7] Stainless steel precision ball bearing. Substitute 'SSPBB' for 'PBB' in order number. [example: SSLS-8300C-UBA-SSPBB]
- [8] \*Bolt hole pattern is slotted to 3-3/8" x 5-1/4".

**Note:** Regarding high capacity stainless steel casters, stainless steel floor locks may be a much more effective alternative to wheel brakes. Contact us for more information.



# SPECIALTY CASTERS & ACCESSORIES

Brake types	60
Floor locks	61
Swivel mechanisms	63
Ladder, door and gate casters	64
Ball transfers and skate wheels	65

# SPECIALTY CASTERS & ACCESSORIES

## Brake types

Bestway offers a variety of brake styles with our casters. Each type offers its own advantages over other types as described below. Our experienced sales staff can assist you in selecting the proper brake type for your specific application. Not all brake types are available with every caster series or wheel type. Consult the options list following each series listing in this catalogue for the brake types offered with that series.

### Side pedal brake [BR]

This pedal style brake is mounted on the side of the caster by way of the axle. Pushing the pedal causes the brake to activate against the side of the wheel preventing the wheel from turning. This is the most economical brake type available.



BW/BR-5150-BAL-RB

### Total lock brake [TLB]

This pedal brake is mounted on the trailing edge of swivel casters only. Depressing the pedal causes the brake to activate against the wheel face, stopping it from turning. At the same time, the swivel lock mechanism activates against the raceway of the caster preventing the caster from swiveling. These brakes may increase the swivel radius on some casters.



GP/TLB-3150C-ES-HRB

### T-handle brake [TBR] and new knob brake [KBR]

This simple, yet effective brake consists of a metal "T" handle threaded into a hole in the side of the caster leg. Turning the handle causes it to activate against the side of the wheel preventing it from turning. This is especially effective on heavier casters where a cam style side pedal brake may not provide sufficient locking pressure.



HX/TBR-6300-DU-RB

### Poly cam brake [PCB]

This highly effective brake is ideal for heavier casters where maximum braking power is required. A poly cam handle mounted on the caster is used to activate a brake plunger firmly against the face of the wheel preventing it from turning. These brakes may increase the swivel radius on some casters.



TWLE/PCB-5200-UBA-PBB

# SPECIALTY CASTERS & ACCESSORIES

## Floor locks

### Stainless steel

These beauties are a fully stainless steel version of our Bestway Series Floor Locks. They are ideal for immobilizing rolling stock or equipment using our SS, SSRT, SSLD, SSHD and SSLE Series stainless steel casters. These Floor Locks work great where conditions prohibit wheel brakes from working properly [i.e. wet or oily floor surfaces, etc.].

Please note that Floor Locks are designed to firmly fix the position of the equipment, NOT to lift it off the floor.



SSFL-4

Order number	Height unlocked	Height locked	Bolt hole centres	Bolt hole spacing	Top plate size	Bolt hole size
FLSS-4	4-1/2"	5-5/8"	3" x 3"	2-5/8" x 3-5/8"	4" x 4-1/2"	3/8"
FLSS-5	5-3/8"	6-1/2"	3" x 3"	2-5/8" x 3-5/8"	4" x 4-1/2"	3/8"
FLSS-6	6-1/2"	7-1/2"	3" x 3"	2-5/8" x 3-5/8"	4" x 4-1/2"	3/8"
FLSS-8	8-1/2"	9-1/2"	3" x 3"	2-5/8" x 3-5/8"	4" x 4-1/2"	3/8"

### Bestway

The Floor Lock is an ideal way to securely immobilize rolling stock or movable equipment. Floor Locks may be welded or bolted to scaffolding, dollies, platform trucks, etc. and utilized when rolling is not required. Our Bestway Series Floor Locks can be used with a wide variety of caster series including the BW, HD, LD, LE, and LH Series.

Please note that Floor Locks are designed to firmly fix the position of the equipment, NOT to lift it off the floor.

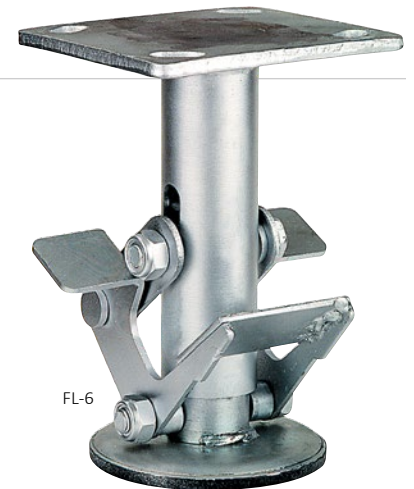

FL-6

Order number	Height unlocked	Height locked	Bolt hole centres	Bolt hole spacing	Top plate size	Bolt hole size
FL-4	4-1/2"	5-5/8"	3" x 3"	2-5/8" x 3-5/8"	4" x 4-1/2"	3/8"
FL-5	5-3/8"	6-1/2"	3" x 3"	2-5/8" x 3-5/8"	4" x 4-1/2"	3/8"
FL-6	6-1/2"	7-1/2"	3" x 3"	2-5/8" x 3-5/8"	4" x 4-1/2"	3/8"
FL-8	8-1/2"	9-1/2"	3" x 3"	2-5/8" x 3-5/8"	4" x 4-1/2"	3/8"

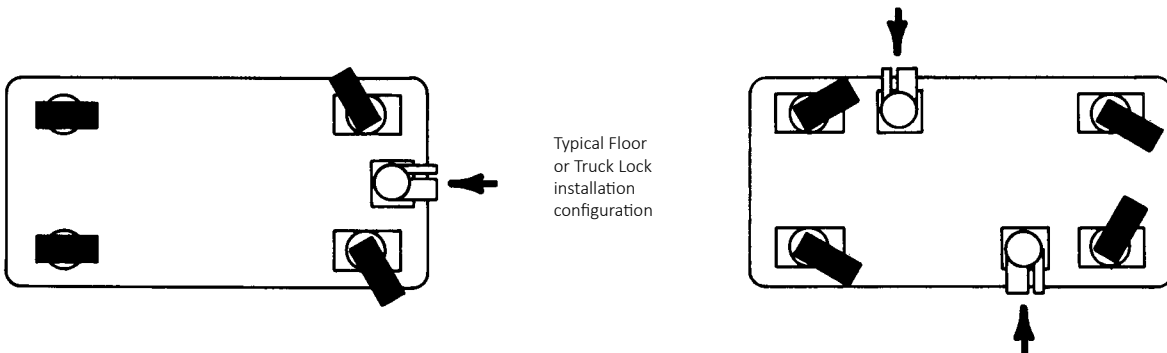

Typical Floor or Truck Lock installation configuration

# SPECIALTY CASTERS & ACCESSORIES

## Floor locks

### Double peddle

This superb floor lock is unmatched in design and performance and is adaptable to all types of portable equipment. The double pedal design will not allow the operator to place his or her foot under the load. The large steel disc foot has a rubber pad for non-slip floor contact. The zinc plated all steel construction eliminates the need for maintenance. To operate, simply press down the large activation pedal to set the positive locking force against the floor. Press down on the release pedal and the spring quickly returns the lock to the non-operating position. Both pedals are on the front of the unit for safety and ease of operation.

Please note that Floor Locks are designed to firmly fix the position of the equipment, NOT to lift it off the floor.



FLD-558

Order number	Height unlocked	Height locked	Bolt hole centres	Bolt hole spacing	Top plate size	Bolt hole size
FLD-558	4-7/8"	5-5/8"	3" x 3"	2-5/8" x 3-5/8"	3-3/4" x 4-5/8"	3/8"
FLD-634	6"	6-3/4"	3" x 3"	2-5/8" x 3-5/8"	3-3/4" x 4-5/8"	3/8"
FLD-734	7"	7-3/4"	3" x 3"	2-5/8" x 3-5/8"	3-3/4" x 4-5/8"	3/8"
FLD-934	9"	9-3/4"	3" x 3"	2-5/8" x 3-5/8"	3-3/4" x 4-5/8"	3/8"

### Truck lock

Cast from steel, these heavy duty truck locks will securely immobilize rolling stock or movable equipment and are easily fitted to virtually any wheeled equipment. Stepping on the pedal activates a toggle action engaging the large, spring-loaded, friction-faced brake pad to prevent inadvertent movement. Pressing the release rod disengages the lock for easy rolling.

Please note that Floor Locks are designed to firmly fix the position of the equipment, NOT to lift it off the floor.



TL-4

Order number	Height unlocked	Height locked	Bolt hole centres	Bolt hole spacing	Top plate size	Bolt hole size
TL-4	4-9/16"	5-5/8"	3" x 3"	2-5/8" x 3-5/8"	4-1/4" x 4-13/16"	3/8"
TL-6	6-11/16"	7-3/4"	2-7/16" x 4-15/16"	3-5/8" x 5-1/4"	4-3/4" x 6-1/2"	1/2"
TL-8	9-1/2"	10-1/2"	2-7/16" x 4-15/16"	3-5/8" x 5-1/4"	4-3/4" x 6-1/2"	1/2"



# SPECIALTY CASTERS & ACCESSORIES

## Swivels

### Swivel mechanisms

These units are ideal for turntables, wagons or any application that requires two surfaces to rotate on a strong base. The BWSM model uses the same proven 5/8" nut and bolt kingpin construction as our BW Series casters. The LDSM, LSSM and IHSM models utilize our revolutionary patented double ball kingboltless technology for unmatched weight capacity and durability. All of our swivel mechanisms can be customized to suit your specific requirements. Other models and mounting plates are available. Contact us.

Order number	Top plate size	Overall height	Swivel type	Load cap.
BWSM	4-1/2" x 6-1/4"	1" + nut	Kingpin	1,500
LDSM	4" x 4-1/2"	1-1/2"	Kingboltless	2,500
LSSM	4-1/2" x 6-1/4"	1-9/16"	Kingboltless	4,500
IHSM	8-1/2" x 8-1/2"	3-3/8"	Kingboltless	3,0000

### Options

[1] Four Position Swivel Lock. Add code '4SL' to order number. [example: LDSM/4SL]. Will increase overall height.

[2] Other sizes and mounting types available. Contact us.

**Note:** Swivel Locks will increase the Overall Height of the unit. Contact us.



BWSM



LDSM

# SPECIALTY CASTERS & ACCESSORIES

## Ladder, door and gate casters

### Ladder and door casters

Ladder and Door Casters use mounting brackets and compression springs to support the weight of a gate, door or ladder for easier movement and reduced wear on hinges/pivots. The LC Series uses a 25 lb compression spring, while the heavier DC Series uses a more robust 100 lb compression spring. For heavier or custom applications please see our GC Series Gate Casters [ below ].

Order number	Plate size and hole spacing	Wheel type	Load cap.
<b>2" Ø wheels</b>			
LC-2	1" x 3-3/8" c/w 2 holes 2-1/8" BHS	Multi-Purpose Rubber	75
DC-2	2" x 5-1/8" c/w 4 holes 1-1/4" x 3" BHS	Multi-Purpose Rubber	75
<b>3" Ø wheels</b>			
LC-3	1" x 3-3/8" c/w 2 holes 2-1/8" BHS	Multi-Purpose Rubber	100
DC-3	2" x 5-1/8" c/w 4 holes 1-1/4" x 3" BHS	Multi-Purpose Rubber	125

**Note:** Other sizes may be available. Contact us.

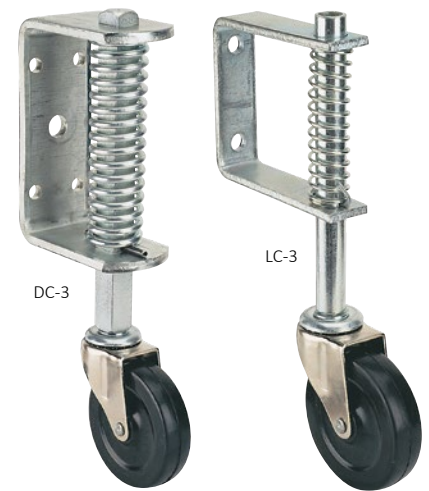

### Gate casters

These high-capacity Gate Casters are ideal for use on heavy doors, gates, uneven floors or anywhere spring action is needed. The 11" x 4" plate is mounted with eight 3/8" bolts. The heavy duty compression spring helps support the weight of the gate. Travel distance of spring approximately 1". These casters are commonly used on Ice Rink gates.

Order number	Width	Wheel type	Bearing type	Load cap.
<b>5" Ø wheels</b>				
GC-5200-MR-RB	2"	Multi-Purpose Rubber	Roller	550
GC-5200C-ES-PBB	2"	Solid Elastomer [Crowned]	Precision Ball	700
<b>6" Ø wheels</b>				
GC-6200-MR-RB	2"	Multi-Purpose Rubber	Roller	650
GC-6200C-ES-PBB	2"	Solid Elastomer [Crowned]	Precision Ball	700

**Note:** Other sizes and wheel types are available. Contact us.

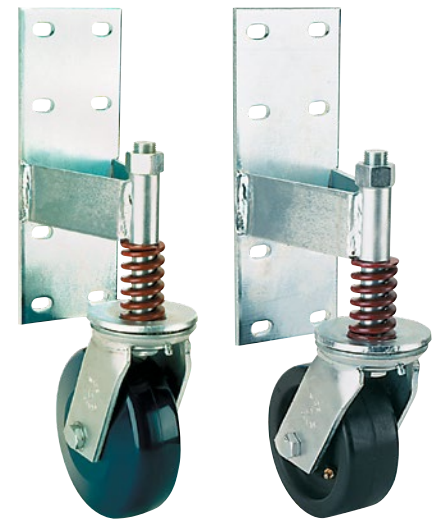

GC-6200C-ES-PBB

GC-5200-MR-RB

# SPECIALTY CASTERS & ACCESSORIES

## Ball transfers and skate wheels

### Flange mounted ball transfers

These all-steel rollers are designed for ball-up applications on material handling systems. The flanged base features two [BT-10], or four [BT-15] mounting holes to facilitate easy installation and allow for quick and simple field replacement.

The BT-10 features a 1" diameter carbon steel ball rotating on 1/8" support balls mounted in a steel cup. The 1-11/16" diameter housing is zinc plated for a lasting, attractive finish.

The high capacity BT-15 features a 1-1/2" diameter carbon steel ball fitted with a moulded nylon seal. The main ball rotates on 3/16" hardened and ground support balls in a precision formed and hardened cup. The protective cover prohibits entry of dirt and foreign matter. The 2-19/32" diameter housing is zinc plated for an attractive and long lasting finish.

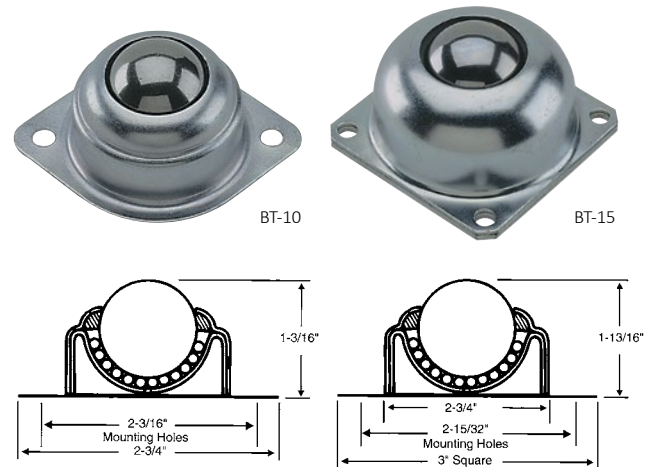

Order number	Ball diameter	Overall height	Ball type	Bolt hole spacing	Mount hole size	Static load cap.	Dynamic load cap.
BT-10	1"	1-3/16"	Steel	2-3/16"	7/32"	75 lbs.	65 lbs.
BT-15	1-1/2"	1-13/16"	Steel	2-15/32" x 2-15/32"	9/32"	250 lbs.	200 lbs.

**Note:** Other sizes and materials [including stainless steel and nylon ball] may be available. Contact us.

### Single stud mounted ball transfers

These all-steel rollers are designed for ball-up applications on material handling systems. This model is mounted using a 5/16"-18 x 11/16" threaded stud. The 1" diameter carbon steel ball rotates on 1/8" support balls mounted in a steel cup. The housing is zinc plated for a lasting, attractive finish.

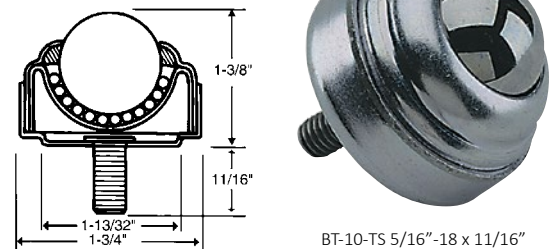

Order number	Ball diameter	Overall height	Ball type	Mounting stud length	Mount stud size	Static load cap.	Dynamic load cap.
BT-10-TS 5/16"-18 x 11/16"	1"	1-3/8"	Steel	11/16"	5/16"-18	75 lbs.	65 lbs.

**Note:** Other sizes and materials [including stainless steel] may be available. Contact us.

### Conveyor skate wheel

These industry standard skate wheels are typically used grouped together in conveyor systems. The 1-15/16" diameter formed steel wheels feature a 1/4" bore and 15/16" hub length.

**Note:** Other sizes may be available. Contact us.

Capacity: 150 lbs. [dynamic load]



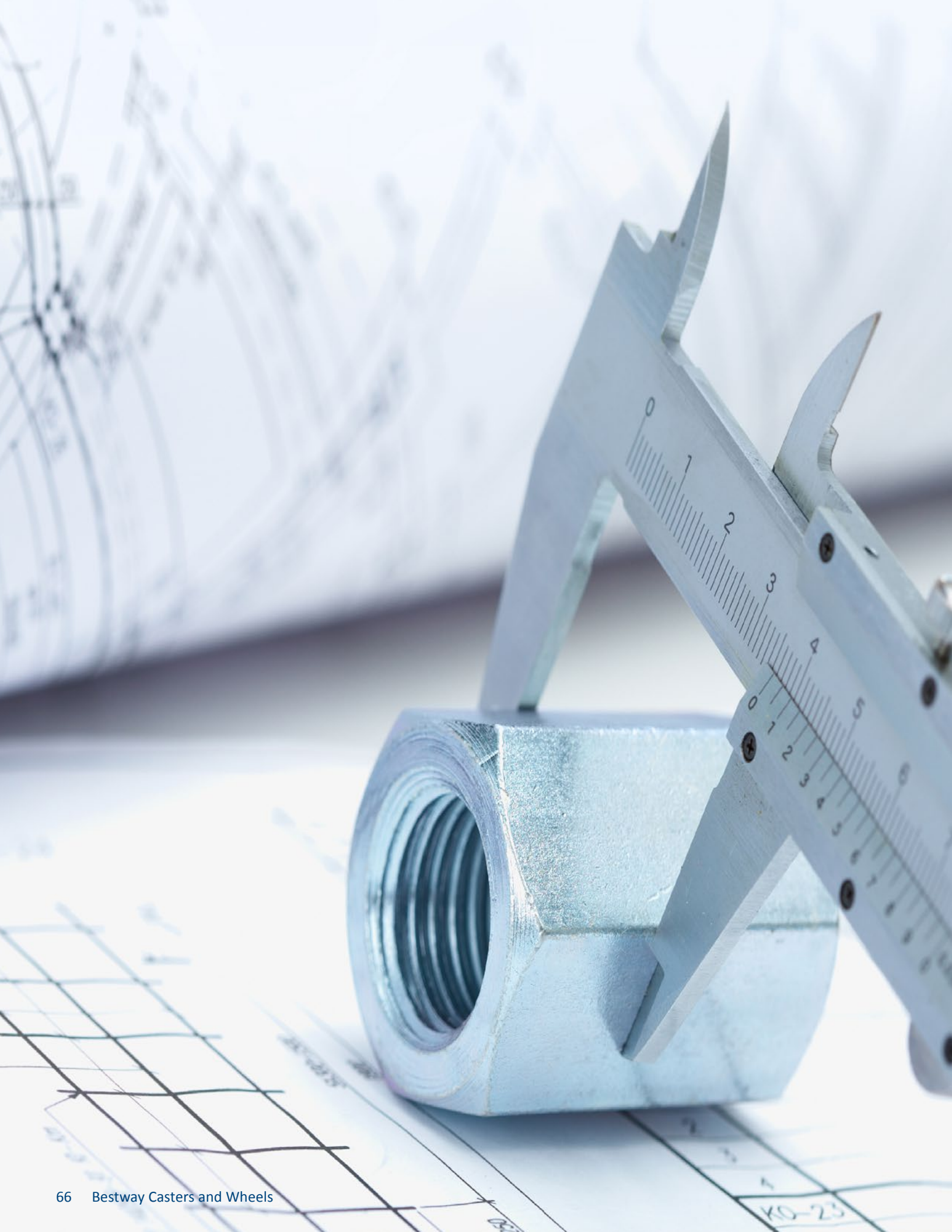

# FITTINGS

Stems	67
Top plates	68

# FITTINGS

## Stems

### BH Series standard stems

Order number	Stem type	Stem material
BH STEM: 3/4" PT	Pipe Thread Stem	Zinc Plated
BH STEM: 7/16" x 1-3/8" SC	Stem & Circlip	Zinc Plated
BH STEM: 5/8" x 1-5/8" SC	Stem & Circlip	Zinc Plated
BH STEM: .845" x 2-1/2" SC	Stem & Circlip	Zinc Plated
BH STEM: 7/8" x 2" SC	Stem & Circlip	Zinc Plated
BH STEM: 3/4" x 2" SQ C/W THREE 1/4" DRIFT HOLES	Square Stem	Zinc Plated
BH STEM: 1/2"-13 x 1-1/2" TS	Threaded Stem	Zinc Plated/Steel
BH STEM: 5/8"-11 x 2" TS	Threaded Stem	Zinc Plated
BH STEM: 3/4"-10 x 2-1/4" TS	Threaded Stem	Zinc Plated

**Notes:** Stems are intended to mount the caster flush with the mounting surface and must not be used for load levelling purposes. Specific stem selections may result in reduced overall caster capacities. Contact us.

### SSBH Series standard stems

Order number	Stem type	Stem material
SSBH STEM: 7/16" x 1-3/8" SC	Stem & Circlip	Stainless Steel
SSBH STEM: 5/8" x 1-5/8" SC	Stem & Circlip	Stainless Steel
SSBH STEM: .845" x 2-1/2" SC	Stem & Circlip	Stainless Steel
SSBH STEM: 7/8" x 2" SC	Stem & Circlip	Stainless Steel
SSBH STEM: 3/4" x 2" SQ C/W THREE 1/4" DRIFT HOLES	Square Stem	Stainless Steel
SSBH STEM: 1/2"-13 x 1-1/2" TS C/W LOCKWASHER & NUT	Threaded Stem	Stainless Steel
SSBH STEM: 5/8"-11 x 2" TS	Threaded Stem	Stainless Steel
SSBH STEM: 3/4"-10 x 2" TS	Threaded Stem	Stainless Steel

**Notes:** Stems are intended to mount the caster flush with the mounting surface and must not be used for load levelling purposes. Specific stem selections may result in reduced overall caster capacities. Contact us.

### RT/RTR Series standard stems

Order number	Stem type	Stem material
RT STEM: 3/4" x 4" PS	Plain Stem	Zinc Plated
RT STEM: 7/8" x 4" PS	Plain Stem	Zinc Plated
RT STEM: 1" x 4" PS	Plain Stem	Zinc Plated
RT STEM: 1-3/8" x 4" PS	Plain Stem	Zinc Plated
RT STEM: .845" x 2-1/2" SC	Stem & Circlip	Zinc Plated
RT STEM: 7/8" x 2" SC	Stem & Circlip	Zinc Plated
RT STEM: 3/4"-10 x 2-1/4" TS	Threaded Stem	Zinc Plated
RT STEM: 3/4"-10 x 4" TS	Threaded Stem	Zinc Plated
RT STEM: 1"-8 x 4" TS	Threaded Stem	Zinc Plated

**Notes:** Stems are intended to mount the caster flush with the mounting surface and must not be used for load levelling purposes. Specific stem selections may result in reduced overall caster capacities. Contact us.

### SSRT Series standard stems

Order number	Stem type	Stem material
SSRT STEM: 3/4" x 4" PS	Plain Stem	Stainless Steel
SSRT STEM: 7/8" x 4" PS	Plain Stem	Stainless Steel
SSRT STEM: 1" x 4" PS	Plain Stem	Stainless Steel
SSRT STEM: 1-3/8" x 4" PS	Plain Stem	Stainless Steel
SSRT STEM: .845" x 2-1/2" SC	Stem & Circlip	Stainless Steel
SSRT STEM: 7/8" x 2" SC	Stem & Circlip	Stainless Steel
SSRT STEM: 3/4"-10 x 2" TS	Threaded Stem	Stainless Steel
SSRT STEM: 3/4"-10 x 4" TS	Threaded Stem	Stainless Steel
SSRT STEM: 1"-8 x 4" TS	Threaded Stem	Stainless Steel

**Notes:** Stems are intended to mount the caster flush with the mounting surface and must not be used for load levelling purposes. Specific stem selections may result in reduced overall caster capacities. Contact us.

## Custom stems? No problem!

At Bestway Casters and Wheels we manufacture our own stems. Nothing is imported. This means that custom designs are no problem! If our standard stem models just won't do, tell us what you need and we'll make it for you. In-house machining means faster delivery and lower cost.

Here's just a sample of the types of custom stems we can manufacture for you:

- Steel, zinc plated or stainless steel material
- Fully or partially threaded stems
- Standard or custom threads and pitches
- Virtually any length or diameter of material
- Round, square, hex or channel steel stems
- Stem & Circlip [grip ring] stems
- Cross holes
- Custom mounting brackets [gate casters, etc.]

# FITTINGS

Top plate templates [actual size]

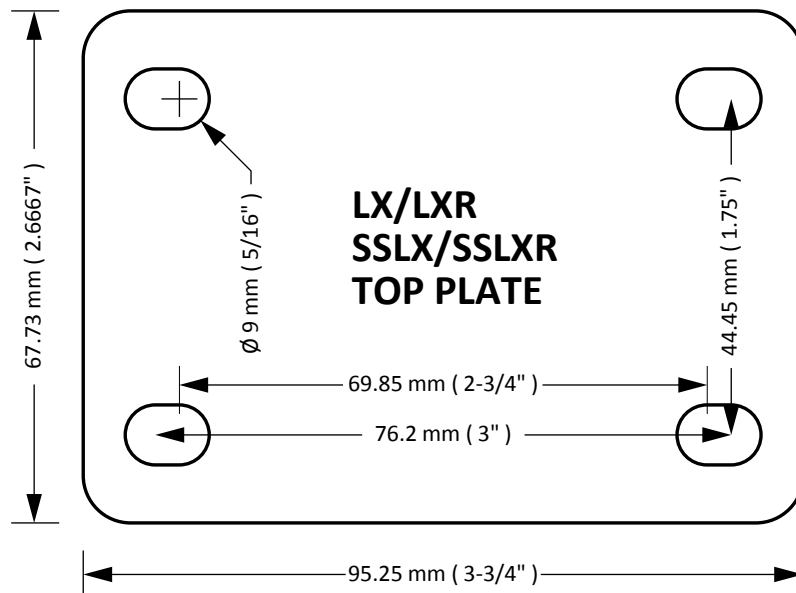
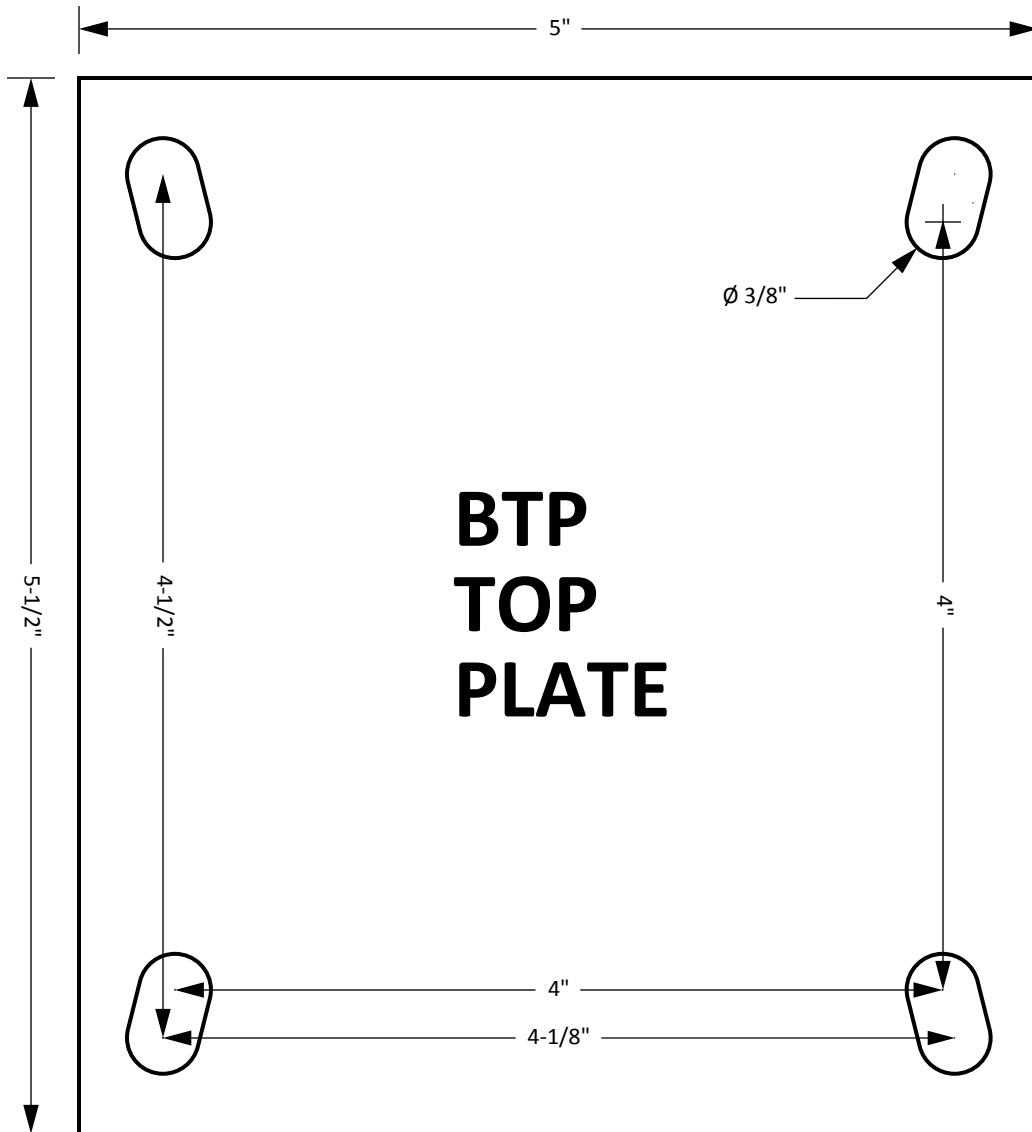

# FITTINGS

Top plate template [actual size]

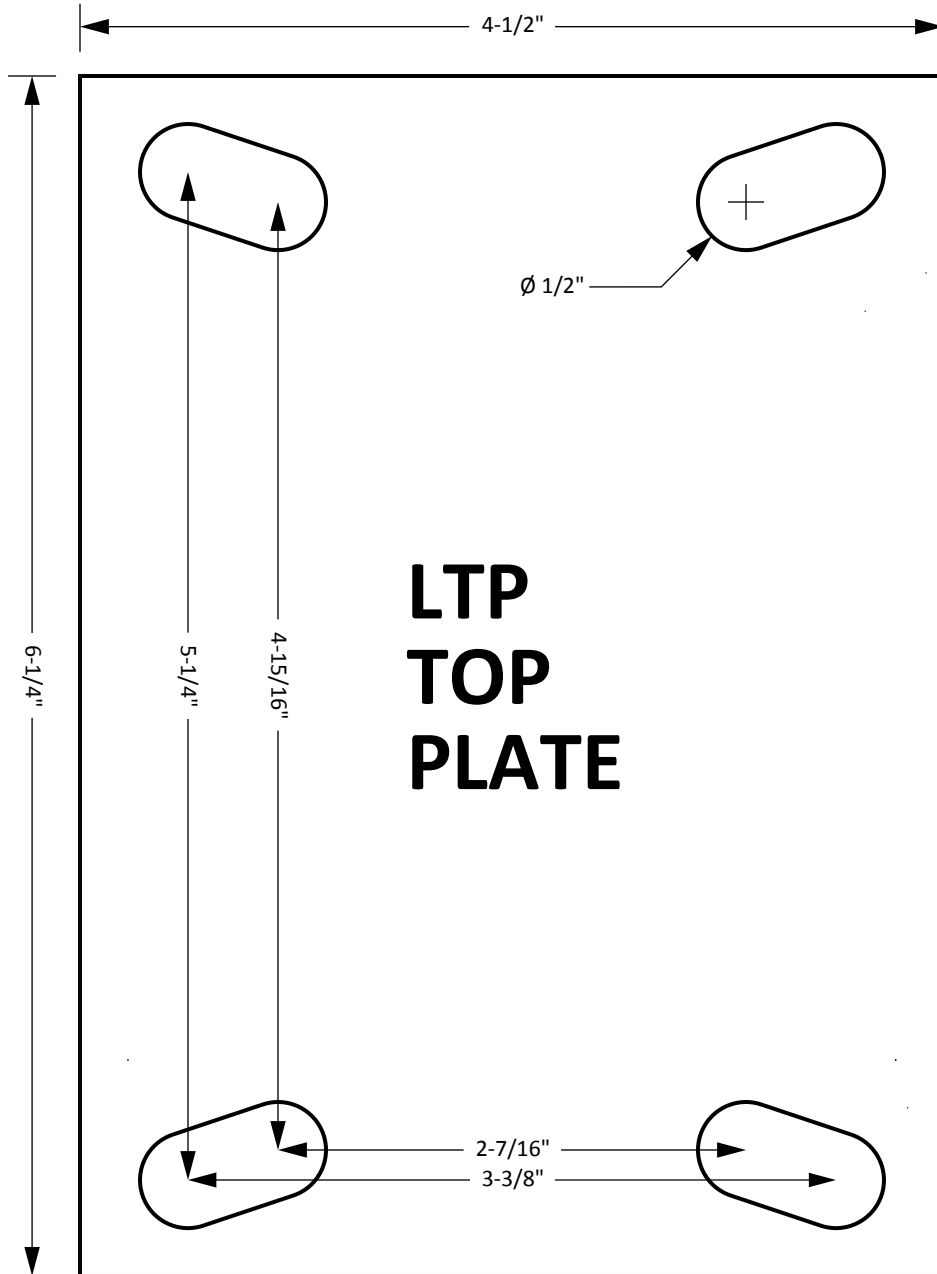



# FITTINGS

Top plate templates [actual size]

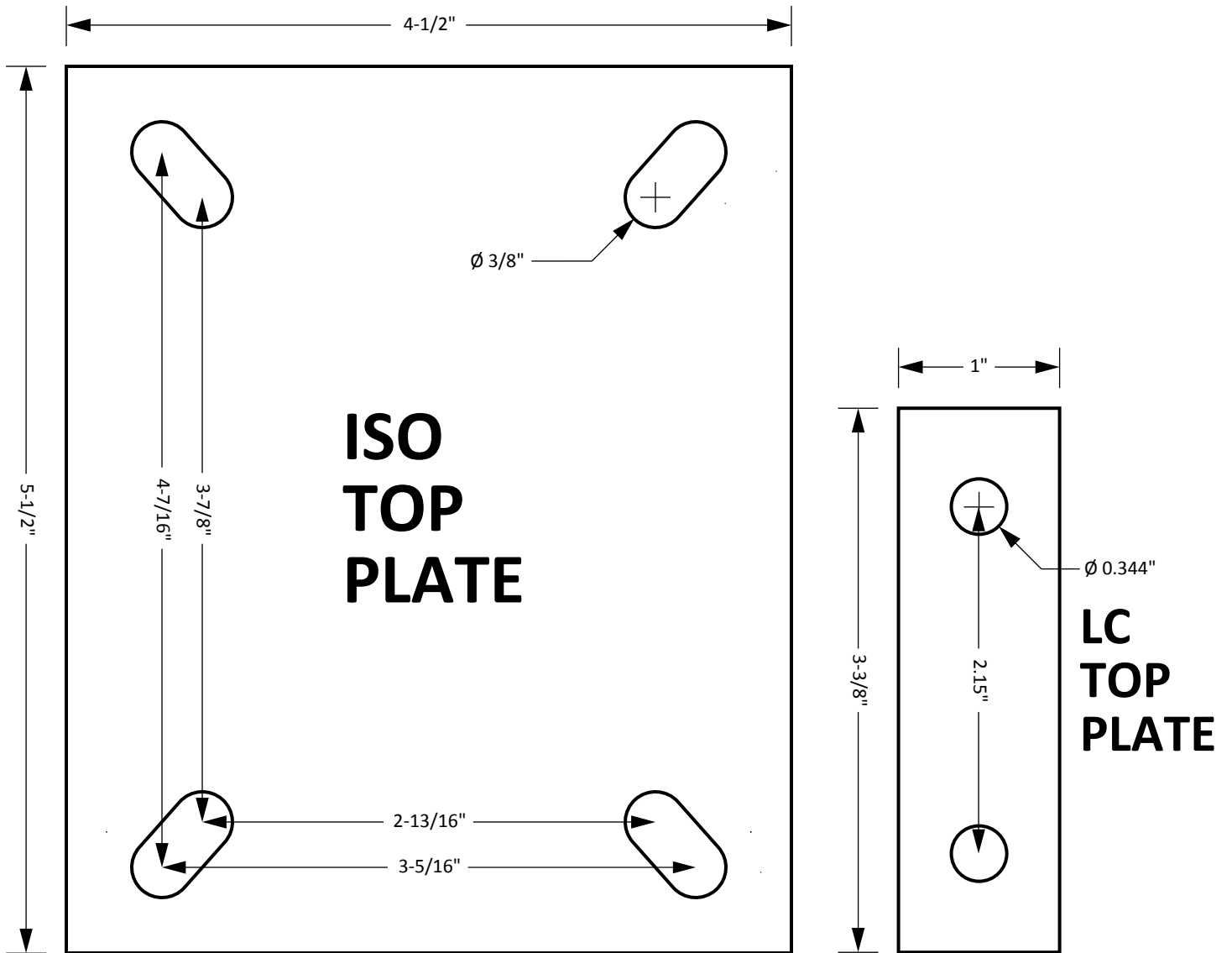

# FITTINGS

Top plate templates [actual size]

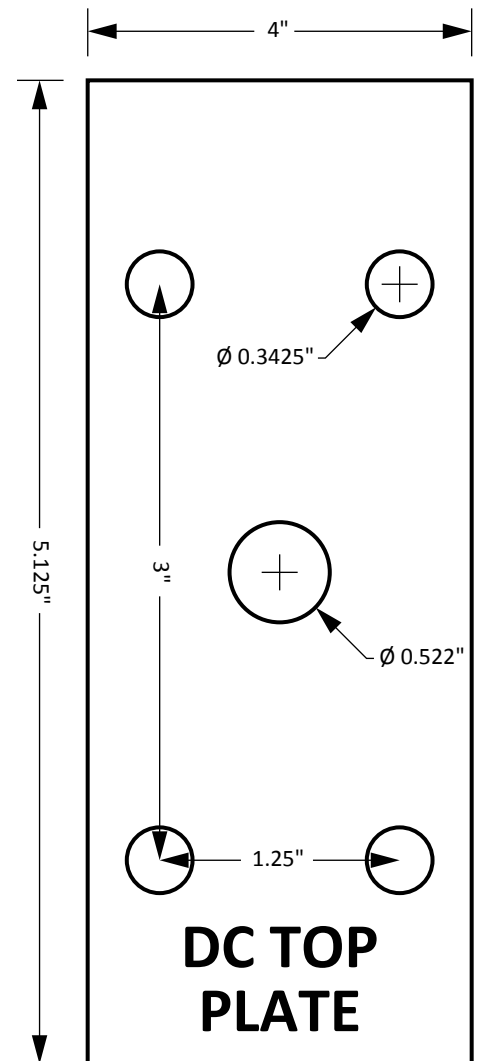
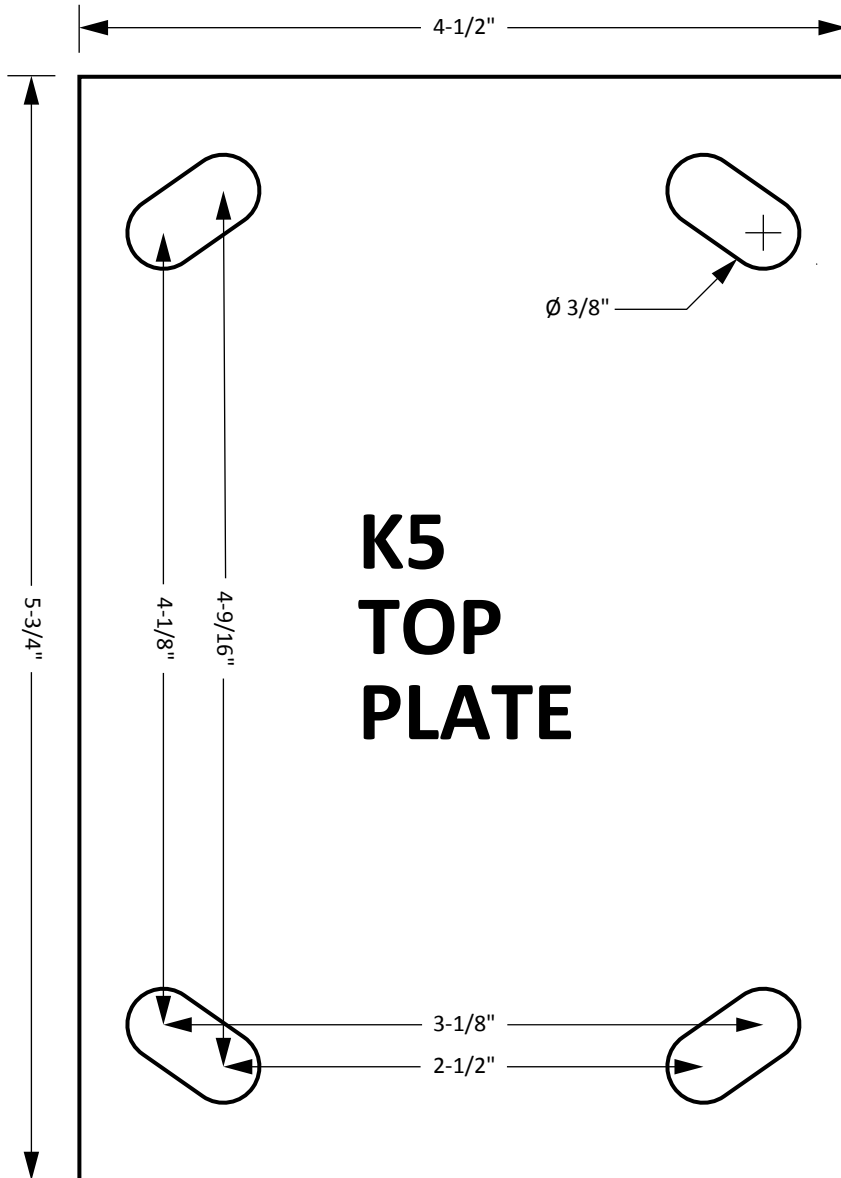

# FITTINGS

Top plate templates [actual size]

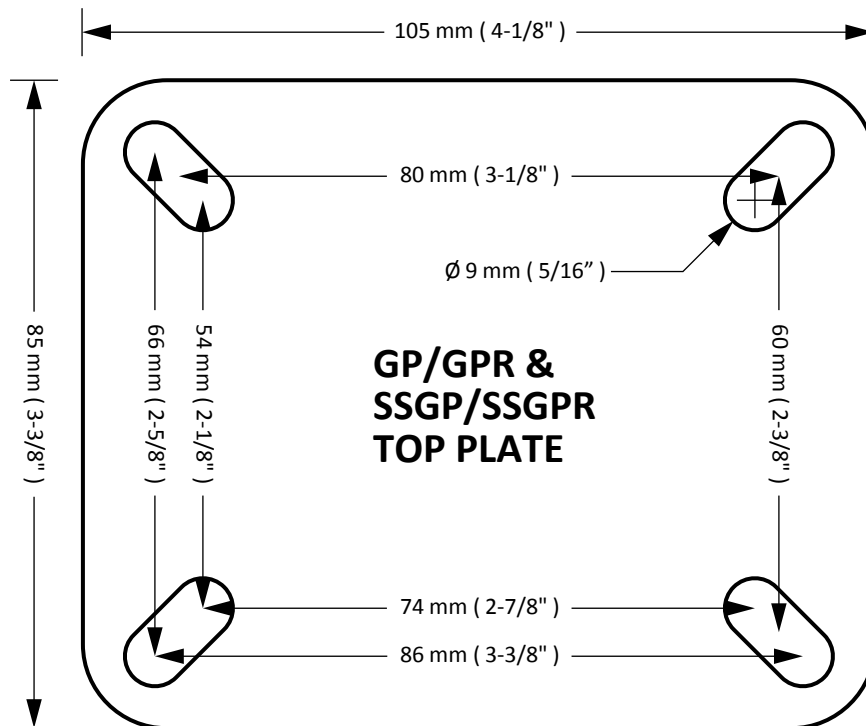
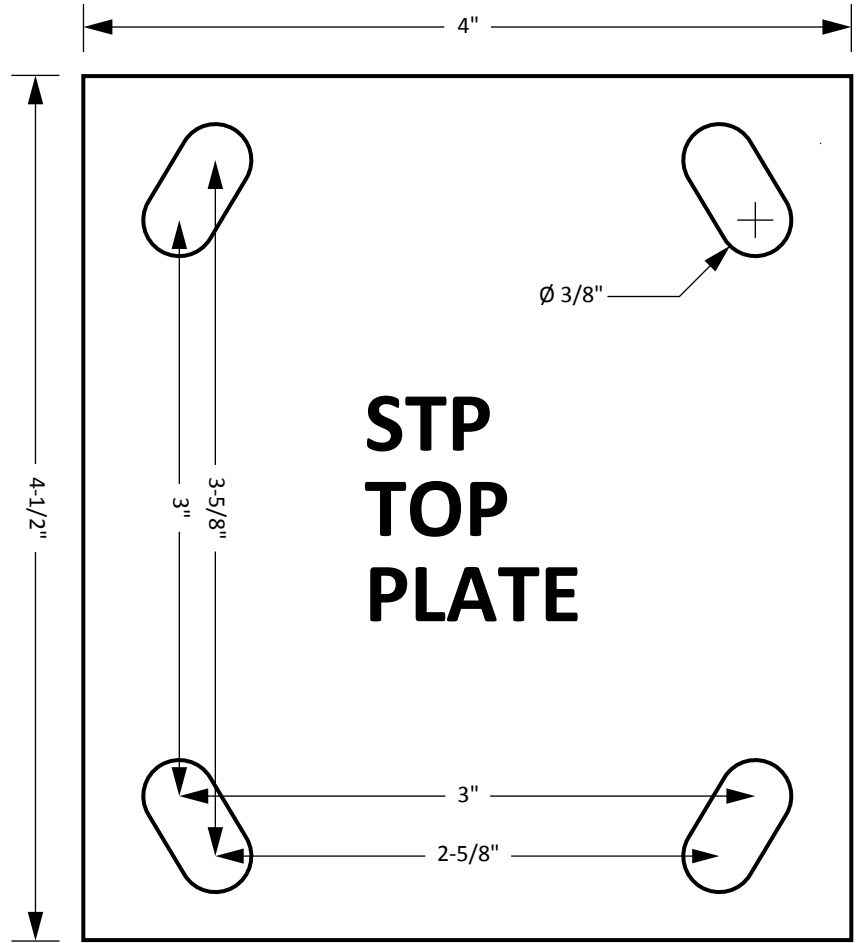
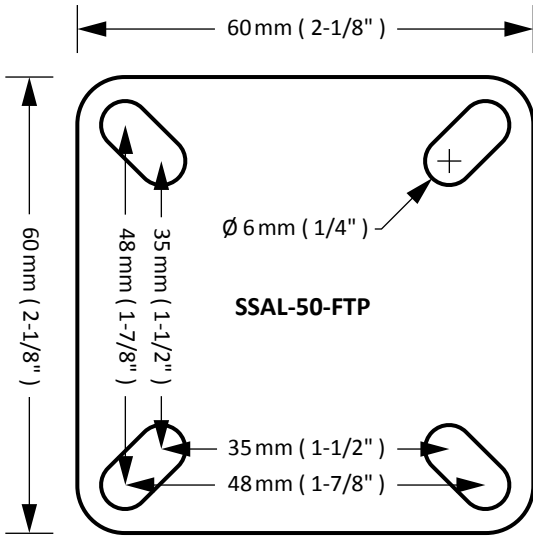

# FITTINGS

Top plate template [actual size]

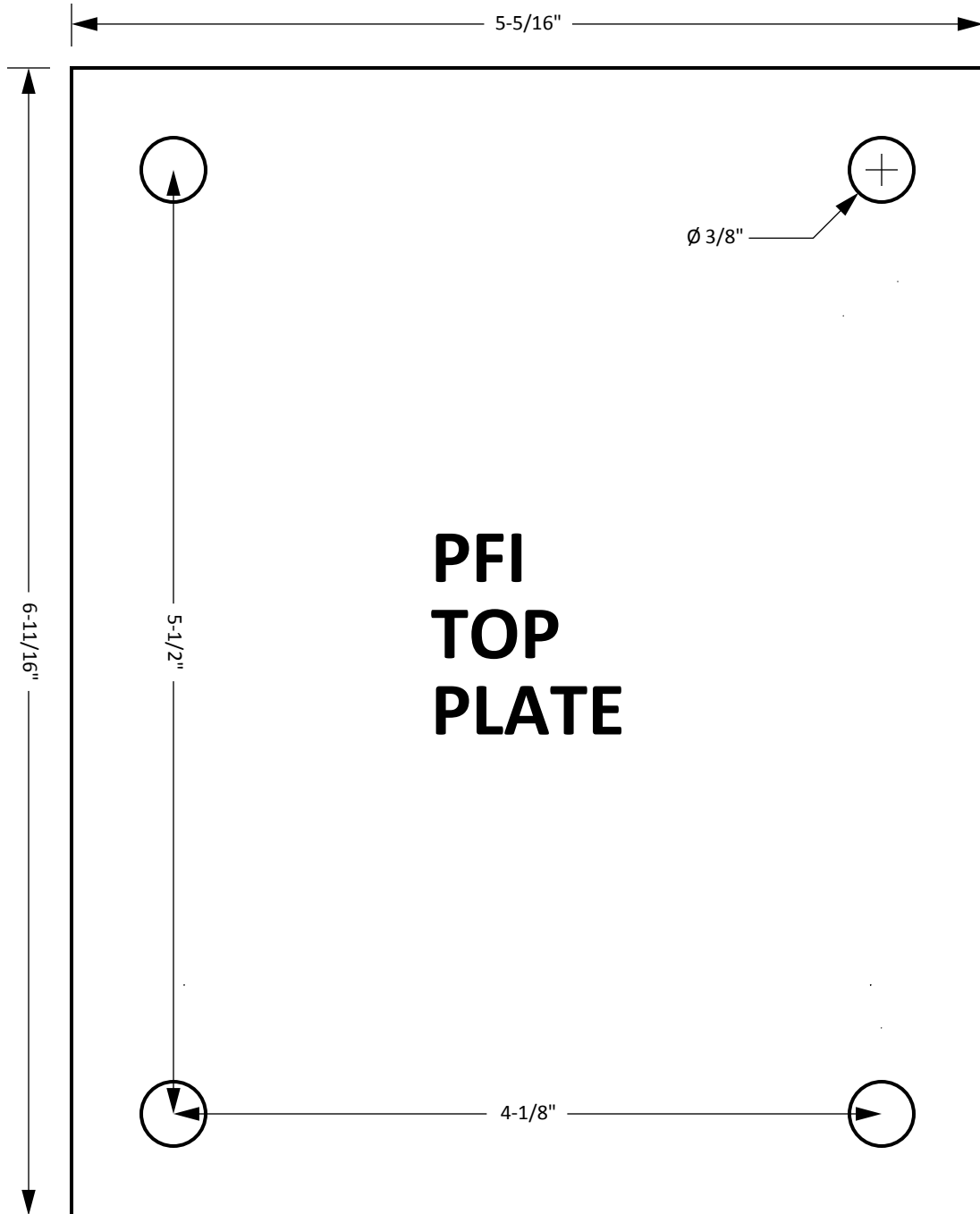

# FITTINGS

Plate template [75% actual size]

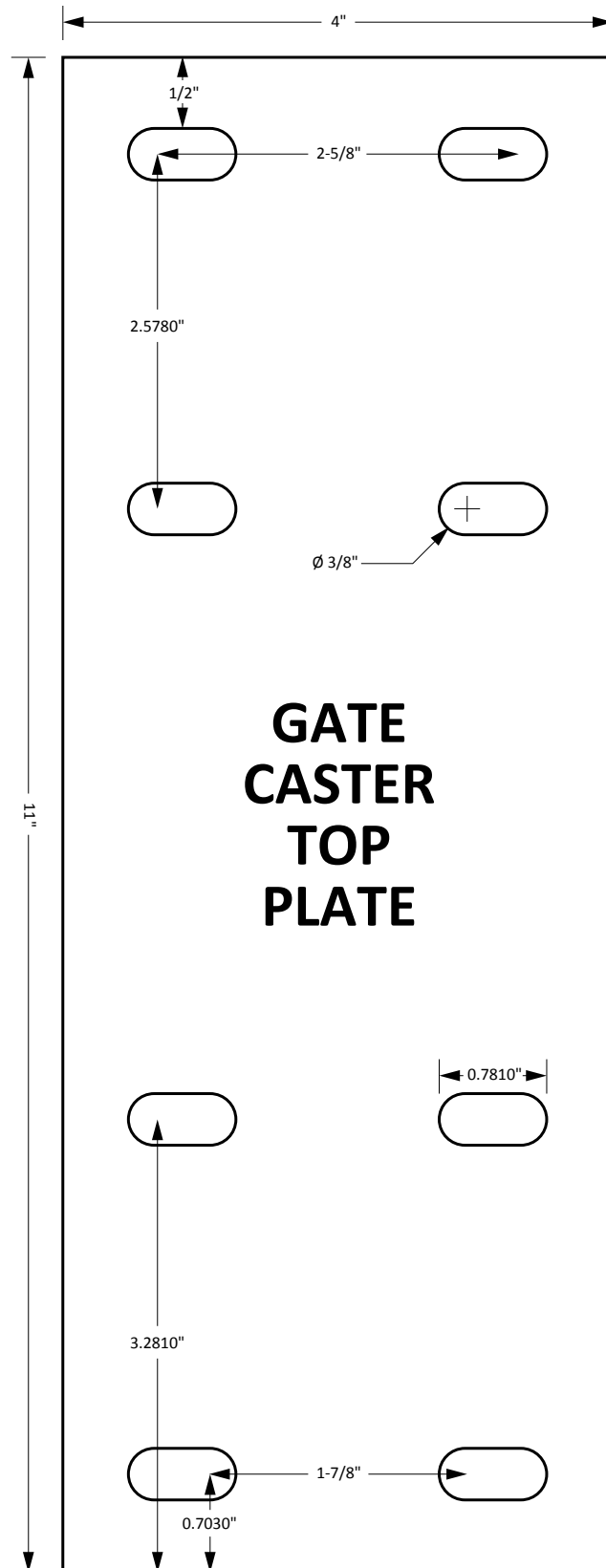



# REPLACEMENT WHEELS

Phenolic	79
Monolithic	81
Cast steel, ductile iron, steel and stainless steel	82
Urethane	88
Rubber	95
Polyolefin	98
Nylon	100
PAL series pallet	101

# SELECTING THE RIGHT WHEEL

With so many wheel types available to choose from, it can be difficult to select the right wheel for your application. Contact our experienced sales staff to ensure that you get the wheel that will work best for you. Here are a few general tips to help you decide what type of wheel you need:

- Larger diameter wheels roll easier than smaller diameter wheels.
- The harder the tread surface of the wheel, the easier it will roll.
- Crowned tread wheels offer better mobility than flat profile tread wheels since there is less surface contact between the wheel and the floor. Crowned is sometimes referred to as round profile.
- Polyurethane has a higher load bearing capacity than rubber and is much more resistant to abrasion and tearing.
- Polyurethane is available in a broad hardness range [eraser soft to bowling ball hard].
- Polyolefin/polypropylene/polyethylene, nylon or plastic core wheels are light weight and corrosion resistant. They carry less weight than metal hub wheels.
- Aluminum core wheels are corrosion resistant and offer greater load capacity than non-metal types. They have a lower load capacity than cast steel or ductile iron types.
- Ductile iron types offer higher capacities than cast steel and will not chip, crack or split.
- Monolithic wheels [i.e. wheels made completely from one material] are not subject to tread separation, such as may occur on wheels with treads bonded to a metal, polyolefin or plastic core.



# WHEELS

## Phenolic

### BAL Series “Best-A-Lex” phenolic

Our “Best-A-Lex” phenolic wheels are made of macerated canvas or fibre-filler impregnated with phenolic resin and moulded under extreme heat and pressure into a product with a uniformly hard, smooth finish. The resulting wheel is resistant to corrosion from oil, water, grease, and commonly used solvents, and will not spark. It’s uniformly hard surface means that it rolls very easily, but it is not as hard on floor surfaces as metal wheels and will not leave marks like some rubber wheels do. They can be operated continuously in temperatures from -50°F to 250°F and intermittently up to 300°F.

Special high-capacity types [ LAM Series ] and high-temperature versions [ HT Series ] are also available.

We use only North American made phenolic wheels to ensure quality and availability unmatched by inferior imported products.



8200-BAL-RB

Order number	Wheel size	Hub length	Bearing size	Bearing type	Tread profile	Load cap.
<b>3" Ø wheels</b>						
3125-BAL-P	3" x 1-1/4"	1-3/8"	1/2"	Plain	Flat	300
3150-BAL-RB	3" x 1-1/2"	1-5/8"	5/8" or 3/4"	Roller	Flat	600
3200-BAL-RB	3-1/4" x 2"	2-3/16"	5/8" or 3/4"	Roller	Flat	700
<b>4" Ø wheels</b>						
4125-BAL-P	4" x 1-1/4"	1-3/8"	1/2"	Plain	Flat	300
4150-BAL-RB	4" x 1-1/2"	1-5/8"	5/8" or 3/4"	Roller	Flat	600
4200-BAL-RB	4" x 2"	2-3/16"	5/8" or 3/4"	Roller	Flat	800
<b>5" Ø wheels</b>						
5125-BAL-P	5" x 1-1/4"	1-3/8"	1/2"	Plain	Flat	300
5150-BAL-RB	5" x 1-1/2"	1-5/8"	5/8" or 3/4"	Roller	Flat	600
5200-BAL-RB	5" x 2"	2-3/16"	5/8" or 3/4"	Roller	Flat	1,000
<b>6" Ø wheels</b>						
6150-BAL-RB	6" x 1-1/2"	1-5/8"	5/8" or 3/4"	Roller	Flat	800
6200-BAL-RB	6" x 2"	2-3/16"	5/8" or 3/4"	Roller	Flat	1,200
6250S-BAL-RB	6" x 2-1/2"	2-3/4"	1" or 1-1/4"	Roller	Flat	1,600
6250L-BAL-RB	6" x 2-1/2"	3-1/4"	1" or 1-1/4"	Roller	Flat	1,600
6300-BAL-RB	6" x 3"	3-1/4"	1" or 1-1/4"	Roller	Flat	2,000
<b>8" Ø wheels</b>						
8200-BAL-RB	8" x 2"	2-3/16"	5/8" or 3/4"	Roller	Flat	1,400
8250S-BAL-RB	8" x 2-1/2"	2-3/4"	1" or 1-1/4"	Roller	Flat	2,000
8250L-BAL-RB	8" x 2-1/2"	3-1/4"	1" or 1-1/4"	Roller	Flat	2,000
8300-BAL-RB	8" x 3"	3-1/4"	1" or 1-1/4"	Roller	Flat	2,500
<b>10" Ø wheels</b>						
10250S-BAL-RB	10" x 2-1/2"	2-3/4"	1" or 1-1/4"	Roller	Flat	2,400
10250L-BAL-RB	10" x 2-1/2"	3-1/4"	1" or 1-1/4"	Roller	Flat	2,400
10300-BAL-RB	10" x 3"	3-1/4"	1" or 1-1/4"	Roller	Flat	2,500
<b>12" Ø wheels</b>						
12300-BAL-RB	12" x 3"	3-1/4"	1" or 1-1/4"	Roller	Flat	3,500

### Options

- [1] 1/2", 5/8" or 3/4" Delrin bearing [ 1-1/2" and 2" face only ]. Substitute 'DEL' for 'RB' in order number. [ example: 5200-BAL-DEL ]
- [2] 1" or 1-1/4" Delrin bearing [ 2-1/2" and 3" face only ]. Substitute 'DEL' for 'RB' in order number. [ example: 10250L-BAL-DEL ]
- [3] 5/8" or 3/4" Heavy duty roller bearing [ 1-1/2" face only ]. Substitute 'HRB' for 'RB' in order number. [ example: 4150-BAL-HRB ]
- [4] 3/4" Heavy duty roller bearing [ 2" face only ]. Substitute 'HRB' for 'RB' in order number. [ example: 6200-BAL-HRB ]
- [5] 3/4" Brass flanged bearing [ 1-1/2" and 2" face only ]. Substitute 'BF' for 'RB' in order number. [ example: 6200-BAL-BF ]
- [6] 1" Brass flanged bearing [ 2-1/2" and 3" face only ]. Substitute 'BF' for 'RB' in order number. [ example: 12300-BAL-BF ]
- [7] 5/8" or 3/4" Vulcanized rubber seals [ 1-1/2" and 2" face only ]. Add 'VS' to order number. [ example: 6150-BAL-RB-VS ]
- [8] 1" or 1-1/4" Vulcanized rubber seals [ 2-1/2" and 3" face only ]. Add 'VS' to order number. [ example: 8250L-BAL-RB-VS ]
- [9] 1/2" Flanged precision bearing [ 1-1/2" and 2" face only ]. Substitute 'FLPBB' for 'RB' in order number. [ example: 4200-BAL-FLPBB ]
- [10] 3/4" Flanged precision bearing [ 2-1/2" Long and 3" face only ]. Substitute 'FLPBB' for 'RB' in order number. [ example: 8300-BAL-FLPBB ]

**Note:** All wheels can be supplied with steel or stainless steel spanner bushings. See page 107 for complete listing.

# WHEELS

## Phenolic

### LAM Series laminated tread phenolic

This rugged and long lasting wheel is the ultimate phenolic wheel made. Unlike regular phenolics this wheel has laminations in the tread for increased strength and durability. The resulting wheel runs like iron but is still protective of floor surfaces. They can be used in temperatures up to 250° F [ 300° F intermittently ] and are very good around most chemicals.



6200-LAM-RB

Order number	Wheel size	Hub length	Bearing size	Bearing type	Tread profile	Load cap.
<b>4" Ø wheels</b>						
4200-LAM-RB	4" x 2"	2-3/16"	5/8" or 3/4"	Roller	Flat	1,200
<b>5" Ø wheels</b>						
5200-LAM-RB	5" x 2"	2-3/16"	5/8" or 3/4"	Roller	Flat	1,400
<b>6" Ø wheels</b>						
6200-LAM-RB	6" x 2"	2-3/16"	5/8" or 3/4"	Roller	Flat	1,500
6300-LAM-RB	6" x 3"	3-1/4"	1" or 1-1/4"	Roller	Flat	2,500
<b>8" Ø wheels</b>						
8200-LAM-RB	8" x 2"	2-3/16"	5/8" or 3/4"	Roller	Flat	1,700
8300-LAM-RB	8" x 3"	3-1/4"	1" or 1-1/4"	Roller	Flat	3,100

### Options

- [1] 1/2", 5/8" or 3/4" Delrin bearing [ 2" face only ]. Substituted 'DEL' for 'RB' in the order number. [ example: 4200-LAM-DEL ]
- [2] 1" or 1-1/4" Delrin bearing [ 3" face only ]. Substitute 'DEL' for 'RB' in order number. [ example: 6300-LAM-DEL ]
- [3] 3/4" Heavy duty roller bearing [ 2" face only ]. Substitute 'HRB' for 'RB' in order number. [ example: 6200-LAM-HRB ]
- [4] 3/4" Brass flanged bearing [ 2" face only ]. Substitute 'BF' for 'RB' in order number. [ example: 5200-LAM-BF ]
- [5] 1" Brass flanged bearing [ 3" face only ]. Substitute 'BF' for 'RB' in order number. [ example: 8300-LAM-BF ]
- [6] 5/8" or 3/4" Vulcanized rubber seals [ 2" face only ]. Add 'VS' to order number. [ example: 5200-LAM-RB-VS ]
- [7] 1" or 1-1/4" Vulcanized rubber seals [ 3" face only ]. Add 'VS' to order number. [ example: 6300-LAM-RB-VS ]
- [8] 1/2" Flanged precision bearing [ 1-1/2" and 2" face only ]. Substitute 'FLPBB' for 'RB' in order number. [ example: 5200-LAM-FLPBB ]
- [9] 3/4" Flanged precision bearing [ 3" face only ]. Substitute 'FLPBB' for 'RB' in order number. [ example: 8300-LAM-FLPBB ]

**Note:** All wheels can be supplied with steel or stainless steel spanner bushings. See page 107 for complete listing.

# WHEELS

## Phenolic

### HT Series hi-temp phenolic

A special phenolic compound is used to make these wheels resistant to high heat. They can be run continuously at 475°F or intermittently at 525°F. An excellent choice instead of steel.



8200-HT-RB

Order number	Wheel size	Hub length	Bearing size	Bearing type	Tread profile	Load cap.
<b>4" Ø wheels</b>						
4150-HT-RB	4" x 1-1/2"	1-5/8"	5/8" or 3/4"	Roller	Flat	400
4200-HT-RB	4" x 2"	2-3/16"	5/8" or 3/4"	Roller	Flat	500
<b>5" Ø wheels</b>						
5200-HT-RB	5" x 2"	2-3/16"	5/8" or 3/4"	Roller	Flat	750
<b>6" Ø wheels</b>						
6200-HT-RB	6" x 2"	2-3/16"	5/8" or 3/4"	Roller	Flat	900
<b>8" Ø wheels</b>						
8200-HT-RB	8" x 2"	2-3/16"	5/8" or 3/4"	Roller	Flat	1,100

### Options

[1] 5/8" or 3/4" Heavy duty roller bearing [1-1/2" face only]. Substitute 'HRB' for 'RB' in order number. [example: 4150-HT-HRB]

[2] 3/4" Heavy duty roller bearing [2" face only]. Substitute 'HRB' for 'RB' in order number. [example: 6200-HT-HRB]

[3] 3/4" Brass flanged bearing. Substitute 'BF' for 'RB' in order number. [example: 5200-HT-BF]

[4] 3/4" Stainless steel roller bearing. Substitute 'SSRB' for 'RB' in order number. [example: 8200-HT-SSRB]

**Note:** All wheels can be supplied with steel or stainless steel spanner bushings. See page 107 for complete listing.

## Monolithic

### HTM Series hi-temp monolithic

This wheel is designed for high heat applications up to 535°F continuous [570°F intermittent] where steel wheels are not suitable. The special monolithic compound used in these wheels will outwear standard phenolic types at least 2 to 1 and will not flake.

These wheels use our special "Hi-Lex" Teflon® spanner bushings that allow the wheel to continue to turn through the expansion and contraction caused by temperature change where other types squeak and bind.



125-HTM-HL

Order number	Wheel size	Hub length	Bearing size	Bearing type	Tread profile	Load cap.
<b>3" Ø wheels</b>						
080-HTM-HL	3" x 1-5/16"	1-5/8"	5/16"	Hi-Lex	Flat	220
<b>4" Ø wheels</b>						
100-HTM-HL	4" x 1-5/16"	1-5/8"	5/16"	Hi-Lex	Flat	275
<b>5" Ø wheels</b>						
125-HTM-HL	5" x 1-1/2"	1-7/8"	3/8"	Hi-Lex	Flat	330
<b>6" Ø wheels</b>						
150-HTM-RB	6" x 2"	2-3/16"	3/4"	Roller	Flat	660
<b>8" Ø wheels</b>						
200-HTM-RB	8" x 2"	2-3/16"	3/4"	Roller	Flat	880

# WHEELS

## Cast steel, ductile iron, steel and stainless steel

### BST Series cast steel

Bestway's cast steel wheels offer an excellent combination of strength, durability and value. These easy rolling wheels offer good load bearing capability and are an inexpensive alternative to ductile iron models.



6200-BST-RB

Order number	Wheel size	Hub length	Bearing size	Bearing type	Tread profile	Load cap.
<b>3" Ø wheels</b>						
3125-BST-P	3" x 1-1/4"	1-1/2"	1/2"	Plain	Flat	350
3125C-BST-RB	3" x 1-1/4"	1-1/2"	1/2"	Roller	Crowned	450
3150-BST-RB	3" x 1-1/2"	1-5/8"	5/8" or 3/4"	Roller	Flat	600
3200-BST-RB	3" x 2"	2-3/16"	5/8" or 3/4"	Roller	Flat	700
<b>4" Ø wheels</b>						
4125-BST-P	4" x 1-1/4"	1-1/2"	1/2"	Plain	Flat	450
4150-BST-P	4" x 1-1/2"	1-5/8"	5/8"	Plain	Flat	650
4150-BST-RB	4" x 1-1/2"	1-5/8"	5/8" or 3/4"	Roller	Flat	650
4200-BST-RB	4" x 2"	2-3/16"	5/8" or 3/4"	Roller	Flat	800
<b>5" Ø wheels</b>						
5150-BST-RB	5" x 1-1/2"	1-5/8"	5/8" or 3/4"	Roller	Flat	700
5200-BST-RB	5" x 2"	2-3/16"	5/8" or 3/4"	Roller	Flat	825
<b>6" Ø wheels</b>						
6200-BST-RB	6" x 2"	2-3/16"	5/8" or 3/4"	Roller	Flat	1,000
<b>8" Ø wheels</b>						
8200-BST-RB	8" x 2"	2-3/16"	5/8" or 3/4"	Roller	Flat	1,200

### Options

- [1] 5/8" or 3/4" Heavy duty roller bearing [1-1/2" face only]. Substitute 'HRB' for 'RB' in order number. [example: 4150-BST-HRB]
- [2] 3/4" Heavy duty roller bearing [2" face only]. Substitute 'HRB' for 'RB' in order number. [example: 6200-BST-HRB]
- [3] 3/4" Brass flanged bearing [1-1/2" and 2" face only]. Substitute 'BF' for 'RB' in order number. [example: 5200-BST-BF]
- [4] 1" Brass flanged bearing [3" face only]. Substitute 'BF' for 'RB' in order number. [example: 14300-BST-BF]
- [5] 5/8" or 3/4" Vulcanized rubber seals [1-1/2" and 2" face only]. Add 'VS' to order number. [example: 8200-BST-RB-VS]
- [6] 1" or 1-1/4" Vulcanized rubber seals [3" face only]. Add 'VS' to order number. [example: 14300-BST-RB-VS]
- [7] 1/2" Flanged precision bearing [1-1/2" and 2" face only]. Substitute 'FLPBB' for 'RB' in order number. [example: 6200-BST-FLPBB]
- [8] 3/4" Flanged precision bearing [3" face only]. Substitute 'FLPBB' for 'RB' in order number. [example: 14300-BST-FLPBB]

**Note:** All wheels can be supplied with steel or stainless steel spanner bushings. See page 107 for complete listing.

# WHEELS

## Cast steel, ductile iron, steel and stainless steel

### VG Series “V-Groove” cast steel

These “V-Groove” wheels are made from Bestway’s cast steel formula. Designed for use on inverted angle iron tracks, these value-priced wheels give you long life and good performance.

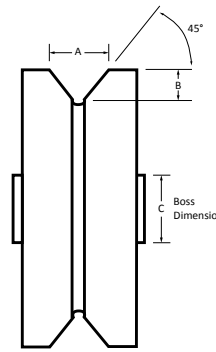

4200-VG-RB

Order number	Wheel size	Hub length	Bearing size	Wheel Dimensions			Bearing type	Load cap.
				A	B	C		
<b>3" Ø wheels</b>								
3150-VG-RB	3" x 1-1/2"	1-5/8"	5/8" or 3/4"	7/8"	7/16"	1-1/2"	Roller	350
<b>4" Ø wheels</b>								
4150-VG-RB	4" x 1-1/2"	1-5/8"	5/8" or 3/4"	7/8"	7/16"	1-5/8"	Roller	500
4200-VG-RB	4" x 2"	2-3/16"	5/8" or 3/4"	7/8"	7/16"	1-5/8"	Roller	800
<b>5" Ø wheels</b>								
5200-VG-RB	5" x 2"	2-3/16"	5/8" or 3/4"	7/8"	7/16"	1-3/4"	Roller	800
<b>6" Ø wheels</b>								
6200-VG-RB	6" x 2"	2-3/16"	5/8" or 3/4"	7/8"	7/16"	1-3/4"	Roller	1,000

### Options

- [1] 5/8" or 3/4" Heavy duty roller bearing [1-1/2" face only]. Substitute ‘HRB’ for ‘RB’ in order number. [example: 4150-BST-HRB]
  - [2] 3/4" Heavy duty roller bearing [2" face only]. Substitute ‘HRB’ for ‘RB’ in order number. [example: 6200-BST-HRB]
  - [3] 3/4" Brass flanged bearing. Substitute ‘BF’ for ‘RB’ in order number. [example: 5200-BST-BF]
  - [4] 5/8" or 3/4" Vulcanized rubber seals. Add ‘VS’ to order number. [example: 8200-BST-RB-VS]
  - [5] 1/2" Flanged precision bearing [1-1/2" and 2" face only]. Substitute ‘FLPBB’ for ‘RB’ in order number. [example: 3150-VG-FLPBB]
- Note:** All wheels can be supplied with steel or stainless steel spanner bushings. See page 107 for complete listing.

### DU Series ductile iron

Ductile iron wheels are far superior to cast and forged steel products. Also referred to as “malleable iron”, these wheels are unbelievably resistant to breakage, chipping and cracking, even under the most severe impact loadings. The special alloys used in these wheels result in load capacities far beyond those of standard steel wheels. Our heavy duty designs feature fully machined treads that distribute loads over the entire surface for maximum floor protection. These wheels are 100% North American made to guarantee the best possible quality, value and availability.



6200C-DU-RB

10300-DU-RB

Order number	Wheel size	Hub length	Bearing size	Bearing type	Boss dimension	Tread profile	Load cap.
<b>4" Ø wheels</b>							
4200C-DU-RB	4" x 2"	2-3/16"	5/8", 3/4" or 1"	Roller	2"	Crowned	1,800
<b>5" Ø wheels</b>							
5200C-DU-RB	5" x 2"	2-3/16"	5/8", 3/4" or 1"	Roller	2"	Crowned	1,800

### Options

- [1] 3/4" Heavy duty roller bearing [2" face only]. Substitute ‘HRB’ for ‘RB’ in order number. [example: 6200C-DU-HRB]
  - [2] 3/4" Brass flanged bearing [2" face only]. Substitute ‘BF’ for ‘RB’ in order number. [example: 8200C-DU-BF]
  - [3] 1" Brass flanged bearing [2-1/2" and 3" face only]. Substitute ‘BF’ for ‘RB’ in order number. [example: 10250S-DU-BF]
  - [4] 5/8" or 3/4" Vulcanized rubber seals [2" face only]. Add ‘VS’ to order number. [example: 5200C-DU-RB-VS]
  - [5] 1/2" Flanged precision bearing [1-1/2" and 2" face only]. Substitute ‘FLPBB’ for ‘RB’ in order number. [example: 6300-DU-FLPBB]
  - [6] 3/4" Flanged precision bearing [2-1/2" Long and 3" face only]. Substitute ‘FLPBB’ for ‘RB’ in order number. [example: 8300-DU-FLPBB]
- Notes:** All wheels can be supplied with steel or stainless steel spanner bushings. See page 107 for complete listing.

Custom sizes available. Contact us.

# WHEELS

## Cast steel, ductile iron, steel and stainless steel

### DU Series ductile iron

Ductile iron wheels are far superior to cast and forged steel products. Also referred to as “malleable iron”, these wheels are unbelievably resistant to breakage, chipping and cracking, even under the most severe impact loadings. The special alloys used in these wheels result in load capacities far beyond those of standard steel wheels. Our heavy duty designs feature fully machined treads that distribute loads over the entire surface for maximum floor protection. These wheels are 100% North American made to guarantee the best possible quality, value and availability.



6200C-DU-RB

10300-DU-RB

Order number	Wheel size	Hub length	Bearing size	Bearing type	Boss dimension	Tread profile	Load cap.
<b>6" Ø wheels</b>							
6200C-DU-RB	6" x 2"	2-3/16"	5/8", 3/4" or 1"	Roller	2"	Crowned	1,800
6250S-DU-RB	6" x 2-1/2"	2-3/4"	1" or 1-1/4"	Roller	3"	Flat	3,500
6250L-DU-RB	6" x 2-1/2"	3-1/4"	1" or 1-1/4"	Roller	3"	Flat	3,500
6300-DU-RB	6" x 3"	3-1/4"	1" or 1-1/4"	Roller	3"	Flat	6,000
6300-DU-TB	6" x 3"	3-1/2"	3/4" or 1"	Tapered	3"	Flat	10,000
6300C-DU-RB	6" x 3"	3-1/4"	1" or 1-1/4"	Roller	3"	Crowned	6,000
6300C-DU-TB	6" x 3"	3-1/2"	3/4" or 1"	Tapered	3"	Crowned	8,000
6400-DU-RB	6" x 4"	4-1/4"	1-1/4" or 1-1/2"	Roller	3-1/2"	Flat	8,000
6400-DU-TB [HD] 1-1/4"	6" x 4"	4-1/2"	1-1/4"	Tapered	3-1/2"	Flat	17,000
<b>8" Ø wheels</b>							
8200C-DU-RB	8" x 2"	2-3/16"	5/8", 3/4" or 1"	Roller	2"	Crowned	2,000
8250S-DU-RB	8" x 2-1/2"	2-3/4"	1" or 1-1/4"	Roller	2-3/4"	Flat	3,500
8250L-DU-RB	8" x 2-1/2"	3-1/4"	1" or 1-1/4"	Roller	2-3/4"	Flat	3,500
8300-DU-RB	8" x 3"	3-1/4"	1" or 1-1/4"	Roller	3"	Flat	6,000
8300-DU-TB	8" x 3"	3-1/2"	3/4" or 1"	Tapered	3"	Flat	10,000
8300C-DU-RB	8" x 3"	3-1/4"	1" or 1-1/4"	Roller	3"	Crowned	6,000
8300C-DU-TB	8" x 3"	3-1/2"	3/4" or 1"	Tapered	3"	Crowned	8,000
8400-DU-RB	8" x 4"	4-1/4"	1-1/4" or 1-1/2"	Roller	3-5/8"	Flat	8,000
8400-DU-TB [HD] 1-1/4"	8" x 4"	4-1/2"	1-1/4"	Tapered	3-5/8"	Flat	17,000
<b>10" Ø wheels</b>							
10250S-DU-RB	10" x 2-1/2"	2-3/4"	1" or 1-1/4"	Roller	2-5/8"	Flat	4,500
10250L-DU-RB	10" x 2-1/2"	3-1/4"	1" or 1-1/4"	Roller	2-5/8"	Flat	4,500
10300-DU-RB	10" x 3"	3-1/4"	1" or 1-1/4"	Roller	3-5/8"	Flat	6,000
10300-DU-TB	10" x 3"	3-1/2"	3/4" or 1"	Tapered	3-5/8"	Flat	10,000
10300C-DU-RB	10" x 3"	3-1/4"	1" or 1-1/4"	Roller	3-5/8"	Crowned	6,000
10300C-DU-TB	10" x 3"	3-1/2"	3/4" or 1"	Tapered	3-5/8"	Crowned	8,000
10400-DU-RB	10" x 4"	4-1/4"	1-1/4" or 1-1/2"	Roller	3-1/2"	Flat	8,000
10400-DU-TB [HD] 1-1/4"	10" x 4"	4-1/2"	1-1/4"	Tapered	3-1/2"	Flat	17,000
<b>12" Ø wheels</b>							
12300-DU-RB	12" x 3"	3-1/4"	1" or 1-1/4"	Roller	3-5/8"	Flat	6,000
12300-DU-TB	12" x 3"	3-1/2"	3/4" or 1"	Tapered	3-5/8"	Flat	10,000
12300C-DU-RB	12" x 3"	3-1/4"	1" or 1-1/4"	Roller	3-5/8"	Crowned	6,000
12300C-DU-TB	12" x 3"	3-1/2"	3/4" or 1"	Tapered	3-5/8"	Crowned	8,000
12400-DU-RB	12" x 4"	4-1/4"	1-1/4" or 1-1/2"	Roller	3-1/2"	Flat	8,000
12400-DU-TB [HD] 1-1/4"	12" x 4"	4-1/2"	1-1/4"	Tapered	3-1/2"	Flat	17,000
<b>14" Ø wheels</b>							
14500-DU-RB	14" x 5"	5-1/4"	1-1/2"	Roller	5"	Flat	10,000
14500-DU-TB [HD] 1-1/4"	14" x 5"	5-1/2"	1-1/4"	Tapered	5"	Flat	25,000

# WHEELS

## Cast steel, ductile iron, steel and stainless steel

### VGD Series “V-Groove” ductile iron

These rugged, ductile iron “V-Groove” wheels are made from the same high-performance malleable iron alloys as our DU Series wheels. Precision machined and 100% North American made, these wheels have unmatched resistance to breakage, chipping and cracking. With load capacities far greater than inferior cast or forged steel products, these wheels are the best V-Grooves available on the market.

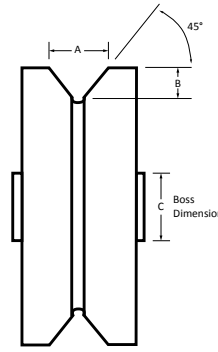

8400-VGD-RB

Order number	Wheel size	Hub length	Bearing size	Wheel Dimensions			Bearing type	Load cap.
				A	B	C		
<b>4" Ø wheels</b>								
4200-VGD-RB	4" x 2"	2-3/16"	5/8", 3/4" or 1"	7/8"	7/16"	2"	Roller	1,500
<b>5" Ø wheels</b>								
5200-VGD-RB	5" x 2"	2-3/16"	5/8", 3/4" or 1"	7/8"	7/16"	2"	Roller	1,500
<b>6" Ø wheels</b>								
6200-VGD-RB	6" x 2"	2-3/16"	5/8", 3/4" or 1"	7/8"	7/16"	2"	Roller	1,800
6250S-VGD-RB	6" x 2-1/2"	2-3/4"	1" or 1-1/4"	7/8"	7/16"	3"	Roller	3,500
6250L-VGD-RB	6" x 2-1/2"	3-1/4"	1" or 1-1/4"	7/8"	7/16"	3"	Roller	3,500
6300-VGD-RB	6" x 3"	3-1/4"	1" or 1-1/4"	1-3/8"	11/16"	3"	Roller	5,000
6300-VGD-TB	6" x 3"	3-1/2"	3/4" or 1"	1-3/8"	11/16"	3"	Tapered	6,000
6400-VGD-RB	6" x 4"	4-1/4"	1-1/4" or 1-1/2"	1-3/4"	7/8"	3-1/2"	Roller	8,000
6400-VGD-TB	6" x 4"	4-1/2"	1-1/4"	1-3/4"	7/8"	3-1/2"	Tapered	17,000
<b>8" Ø wheels</b>								
8200-VGD-RB	8" x 2"	2-3/16"	5/8", 3/4" or 1"	7/8"	7/16"	2"	Roller	2,000
8250S-VGD-RB	8" x 2-1/2"	2-3/4"	1" or 1-1/4"	7/8"	7/16"	3"	Roller	3,500
8250L-VGD-RB	8" x 2-1/2"	3-1/4"	1" or 1-1/4"	7/8"	7/16"	3"	Roller	3,500
8300-VGD-RB	8" x 3"	3-1/4"	1" or 1-1/4"	1-3/8"	11/16"	3"	Roller	5,000
8300-VGD-TB	8" x 3"	3-1/2"	3/4" or 1"	1-3/8"	11/16"	3"	Tapered	6,000
8400-VGD-RB	8" x 4"	4-1/4"	1-1/4" or 1-1/2"	1-3/4"	7/8"	3-5/8"	Roller	8,000
8400-VGD-TB	8" x 4"	4-1/2"	1-1/4"	1-3/4"	7/8"	3-5/8"	Tapered	17,000
<b>10" Ø wheels</b>								
10300-VGD-RB	10" x 3"	3-1/4"	1" or 1-1/4"	1-3/8"	11/16"	3-5/8"	Roller	5,000
10300-VGD-TB	10" x 3"	3-1/2"	3/4" or 1"	1-3/8"	11/16"	3-5/8"	Tapered	6,000
10400-VGD-RB	10" x 4"	4-1/4"	1-1/4" or 1-1/2"	1-3/4"	7/8"	3-1/2"	Roller	8,000
10400-VGD-TB	10" x 4"	4-1/2"	1-1/4"	1-3/4"	7/8"	3-1/2"	Tapered	17,000
<b>12" Ø wheels</b>								
12300-VGD-RB	12" x 3"	3-1/4"	1" or 1-1/4"	1-3/8"	11/16"	3-5/8"	Roller	5,000
12300-VGD-TB	12" x 3"	3-1/2"	3/4" or 1"	1-3/8"	11/16"	3-5/8"	Tapered	6,000
12400-VGD-RB	12" x 4"	4-1/4"	1-1/4" or 1-1/2"	1-3/4"	7/8"	3-1/2"	Roller	8,000
12400-VGD-TB	12" x 4"	4-1/2"	1-1/4"	1-3/4"	7/8"	3-1/2"	Tapered	17,000
<b>14" Ø wheels</b>								
14500-VGD-RB	14" x 5"	5-1/4"	1-1/2"	1-3/4"	7/8"	5"	Roller	10,000
14500-VGD-TB	14" x 5"	5-1/2"	1-1/4"	1-3/4"	7/8"	5"	Tapered	25,000

### Options

- [1] 3/4" Heavy duty roller bearing [2" face only]. Substitute 'HRB' for 'RB' in order number. [ example: 4200-VGD-HRB ]
- [2] 3/4" Brass flanged bearing [2" face only]. Substitute 'BF' for 'RB' in order number. [ example: 6200-VGD-BF ]
- [3] 1" Brass flanged bearing [2-1/2" and 3" face only]. Substitute 'BF' for 'RB' in order number. [ example: 12300-VGD-BF ]
- [4] 5/8" or 3/4" Vulcanized rubber seals [2" face only]. Add 'VS' to order number. [ example: 8200-VGD-RB-VS ]
- [5] 1/2" Flanged precision bearing [1-1/2" and 2" face only]. Substitute 'FLPBB' for 'RB' in order number. [ example: 5200-VGD-FLPBB ]
- [6] 3/4" Flanged precision bearing [2-1/2" Long and 3" face only]. Substitute 'FLPBB' for 'RB' in order number. [ example: 8300-VGD-FLPBB ]

**Notes:** All wheels can be supplied with steel or stainless steel spanner bushings. See page 107 for complete listing.  
Custom sizes available. Contact us.

# WHEELS

## Cast steel, ductile iron, steel and stainless steel

### FLD Series flanged ductile iron

Designed to operate on steel “railroad” type tracks to minimize rolling effort and aid in guidance, these wheels offer superior wear resistance to “V-Groove” types. They are particularly suited to heat treatment operations, marine railroads, travelling cranes, bogey, skips and other transport operations. Using the same high-performance malleable iron alloys as our popular DU and VGD Series, these wheels are incredibly resistant to breakage, chipping and cracking. Load capacities, durability and performance are far superior to inferior cast and forged steel products. 100% North American made and precision machined to guarantee the highest quality, value and availability.

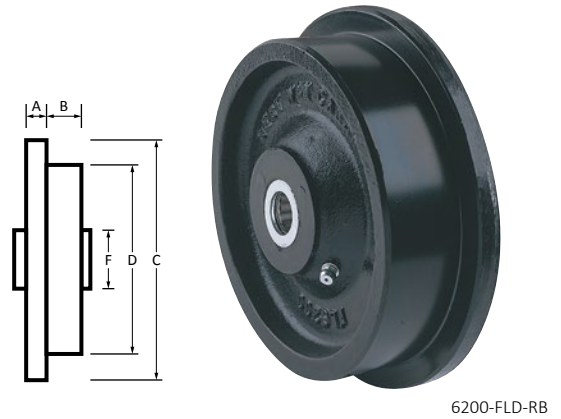

Order number	Wheel size	Hub length	Bearing size	Wheel dimensions					Bearing type	Load cap.
				A	B	C	D	F		
<b>4" Ø wheels</b>										
4200-FLD-RB	4" x 2"	2-3/16"	5/8", 3/4" or 1"	7/16"	1-7/16"	5"	4"	2-1/4"	Roller	1,800
<b>5" Ø wheels</b>										
5200-FLD-RB	5" x 2"	2-3/16"	5/8", 3/4" or 1"	7/16"	1-7/16"	6"	5"	2-1/4"	Roller	1,800
<b>6" Ø wheels</b>										
6200-FLD-RB	6" x 2"	2-3/16"	5/8", 3/4" or 1"	7/16"	1-7/16"	6-7/8"	6"	2-1/4"	Roller	2,000
<b>8" Ø wheels</b>										
8200-FLD-RB	8" x 2"	2-3/16"	5/8", 3/4" or 1"	7/16"	1-9/16"	9"	8"	3-1/2"	Roller	2,000
<b>7-3/4" Ø wheels</b>										
9400-FLD-P	7-3/4" x 2-1/2"	3-11/16"	1-1/2"	5/8"	2-1/2"	9-1/2"	7-3/4"	4-3/16"	Plain	8,500
<b>10" Ø wheels</b>										
10400-FLD-RB	10" x 4"	4-1/4"	1-1/4" or 1-1/2"	1"	3"	12"	10"	4"	Roller	8,000

### Options

- [1] 3/4" Heavy duty roller bearing [ 2" face only ]. Substitute 'HRB' for 'RB' in order number. [ example: 6200-FLD-HRB ]
- [2] 3/4" Brass flanged bearing [ 2" face only ]. Substitute 'BF' for 'RB' in order number. [ example: 8200-FLD-BF ]
- [3] 5/8" or 3/4" Vulcanized rubber seals [ 2" face only ]. Add 'VS' to order number. [ example: 5200-FLD-RB-VS ]
- [4] 1-1/4" or 1-1/2" Vulcanized rubber seals [ 4" face only ]. Add 'VS' to order number. [ example: 10400-FLD-RB-VS ]
- [5] 1/2" Flanged precision bearing [ 2" face only ]. Substitute 'FLPBB' for 'RB' in order number. [ example: 8200-FLD-FLPBB ]

**Notes:** All wheels can be supplied with steel or stainless steel spanner bushings. See page 107 for complete listing.  
Custom sizes available. Contact us.



# WHEELS

## Cast steel, ductile iron, steel and stainless steel

### MS Series machined steel

Bestway's MS Series Machined Steel wheels are precision machined in-house from hot-rolled solid steel bar stock. These "Slab Sided" wheels are highly resistant to shock loads and offer incomparable strength, durability and performance. 100% North American made to ensure the highest possible quality, these wheels can be fully customised to suit your specific application.



4200-MS-RB

Order number	Wheel size	Hub length	Bearing size	Bearing type	Tread profile	Load cap.
<b>4" Ø wheels</b>						
4200-MS-RB	4" x 2"	2-3/16"	5/8", 3/4" or 1"	Roller	Flat	2,000
<b>5" Ø wheels</b>						
5200-MS-RB	5" x 2"	2-3/16"	5/8", 3/4" or 1"	Roller	Flat	2,000
<b>6" Ø wheels</b>						
6200-MS-RB	6" x 2"	2-3/16"	5/8", 3/4" or 1"	Roller	Flat	2,000

### Options

- [1] 3/4" Heavy duty roller bearing. Substitute 'HRB' for 'RB' in order number. [ example: 6200-MS-HRB ]
- [2] 3/4" Brass flanged bearing. Substitute 'BF' for 'RB' in order number. [ example: 5200-MS-BF ]
- [3] 5/8" or 3/4" Vulcanized rubber seals. Add 'VS' to order number. [ example: 5200-MS-RB-VS ]
- [4] 1/2" Flanged precision bearing [ 2" face only ]. Substitute 'FLPBB' for 'RB' in order number. [ example: 4200-MS-FLPBB ]

**Notes:** All wheels can be supplied with steel or stainless steel spanner bushings. See page 107 for complete listing.  
Custom sizes available. Contact us.

### SSMS Series stainless steel machined steel

These unique wheels are precision machined in-house from 303 Stainless Grade bar stock. Ideal for use in high capacity applications where the utility of metal is required but resistance to corrosion and cleanliness are a must. 100% North American made and fully customizable [i.e. V-Grooves, etc. ], these wheels must be seen to be believed!



6200-SSMS-SSRB

Order number	Wheel size	Hub length	Bearing size	Bearing type	Tread profile	Load cap.
<b>4" Ø wheels</b>						
4200-SSMS-SSRB	4" x 2"	2-3/16"	3/4"	Stainless Roller	Flat	1,500
<b>6" Ø wheels</b>						
6200-SSMS-SSRB	6" x 2"	2-3/16"	3/4"	Stainless Roller	Flat	1,800

### Options

- [1] Stainless flanged precision bearing [ 2" face only ]. Substitute 'SSFLPBB' for 'SSRB' in order number. [ example: 4200-SSMS-SSFLPBB ]

**Notes:** All wheels can be supplied with steel or stainless steel spanner bushings. See page 107 for complete listing.  
Custom sizes available. Contact us.

# WHEELS

## Urethane

### UN Series urethane

Polyurethane wheels offer superior abrasion and tear resistance to rubber and are also non-marking and have higher load bearing capacities. Our lightweight UN Series wheels feature a 95A durometer [nominal] Polyurethane tread bonded to a high-impact polyolefin core. The resulting wheel meets the stringent requirements of clinical environments such as the food industry, laboratories as well as the standard of hygiene required in the catering and cleaning professions. It is also ideal for cart wash operations. The hard Polyurethane tread surface makes for an easy rolling wheel that is highly resistant to weather and corrosive environments.



6200-UN-RB

Order number	Wheel size	Hub length	Bearing size	Bearing type	Tread profile	Load cap.
<b>2" Ø wheels</b>						
2-UN-P	2" x 7/8"	1"	1/4"	Plain	Flat	120
<b>3" Ø wheels</b>						
3125-UN-BB	3" x 1-1/4"	1-1/2"	3/8"	Ball Bearing	Flat	250
<b>4" Ø wheels</b>						
4125-UN-BB	4" x 1-1/4"	1-1/2"	3/8"	Ball Bearing	Flat	250
4150-UN-RB	4" x 1-1/2"	1-5/8"	5/8" or 3/4"	Roller	Flat	440
4200-UN-RB	4" x 2"	2-3/16"	5/8" or 3/4"	Roller	Flat	600
<b>5" Ø wheels</b>						
5125-UN-BB	5" x 1-1/4"	1-1/2"	3/8"	Ball Bearing	Flat	250
5150-UN-RB	5" x 1-1/2"	1-5/8"	5/8" or 3/4"	Roller	Flat	500
5200-UN-RB	5" x 2"	2-3/16"	5/8" or 3/4"	Roller	Flat	750
<b>6" Ø wheels</b>						
6150-UN-RB	6" x 1-1/2"	1-5/8"	5/8" or 3/4"	Roller	Flat	600
6200-UN-RB	6" x 2"	2-3/16"	5/8" or 3/4"	Roller	Flat	900
<b>8" Ø wheels</b>						
8200-UN-RB	8" x 2"	2-3/16"	5/8" or 3/4"	Roller	Flat	1,000

### Options

- [1] 1/2" Delrin bearing [ 1-1/4" face only]. Substitute 'DEL' for 'BB' in order number. [ example: 3125-UN-DEL ]
- [2] 1/2", 5/8" or 3/4" Delrin bearing [ 1-1/2" and 2" face only]. Substitute 'DEL' for 'RB' in order number. [ example: 5200-UN-DEL ]
- [3] 1" or 1-1/4" Delrin bearing [ 3" face only]. Substitute 'DEL' for 'RB' in order number. [ example: 8300-UN-DEL ]
- [4] 3/4" Stainless roller bearing [ 1-1/2" and 2" face only]. Substitute 'SSRB' for 'RB' in order number. [ example: 6200-UN-SSRB ]
- [5] 1" Stainless steel roller bearing [ 3" face only]. Substitute 'SSRB' for 'RB' in order number. [ example: 6300-UN-SSRB ]
- [6] 5/8" or 3/4" Vulcanized rubber seals [ 1-1/2" and 2" face only]. Add 'VS' to order number. [ example: 8200-UN-RB-VS ]
- [7] 1" or 1-1/4" Vulcanized rubber seals [ 3" face only]. Add 'VS' to order number. [ example: 8300-UN-RB-VS ]
- [8] 1/2" Flanged precision bearing [ 1-1/2" and 2" face only]. Substitute 'FLPBB' for 'RB' in order number. [ example: 5150-UN-FLPBB ]
- [9] 3/4" Flanged precision bearing [ 3" face only]. Substitute 'FLPBB' for 'RB' in order number. [ example: 8300-UN-FLPBB ]

**Note:** All wheels can be supplied with steel or stainless steel spanner bushings. See page 107 for complete listing.

# WHEELS

## Urethane

### UNY Series urethane on white nylon

This wheel was specially designed for use with our SSGP and SSBH Series Stainless Steel Casters. It features a red 95A durometer [ nominal ] Polyurethane tread bonded to a #6 Nylon core. Stainless steel roller bearings are standard. This wheel is completely waterproof, highly impact and chemical resistant and can safely be steam cleaned. It is ideal for poultry plants, slaughterhouses, cheese plants, hospitals and drug processing industries. The hard Polyurethane tread is easy rolling, non-marking and reasonably quiet.



125-UNY-SSRB

Order number	Wheel size	Hub length	Bearing size	Bearing type	Tread profile	Load cap.
<b>80mm Ø wheels</b>						
080-UNY-SSRB	80mm x 30mm	40mm	12mm	Stainless Roller	Flat	220
<b>100mm Ø wheels</b>						
100-UNY-SSRB	100mm x 30mm	40mm	12mm	Stainless Roller	Flat	240
<b>125mm Ø wheels</b>						
125-UNY-SSRB	125mm x 30mm	46mm	15mm	Stainless Roller	Flat	400

# WHEELS

## Urethane

### UC Series “Urethane on Cast” steel

Our UC Series “Urethane on Cast” wheels are composed of a 95A durometer [nominal] Polyurethane tread formed on a cast steel core. The special bonding process results in a wheel of outstanding shock, load and abrasion resistance. They are much more durable than rubber tread wheels and are highly resistant to most oils, chemicals and solvents. The precision cast core gives it load ratings comparable to steel and the Polyurethane tread is non-marking, relatively quiet, protects the floor surface and has an elastic memory which prevents permanent flat spots.



Order number	Wheel size	Hub length	Bearing size	Bearing type	Tread profile	Load cap.
<b>3" Ø wheels</b>						
3150-UC-RB	3" x 1-1/2"	1-5/8"	5/8" or 3/4"	Roller	Flat	400
3200-UC-RB	3" x 2"	2-3/16"	5/8" or 3/4"	Roller	Flat	540
<b>4" Ø wheels</b>						
4150-UC-RB	4" x 1-1/2"	1-5/8"	5/8" or 3/4"	Roller	Flat	600
4200-UC-RB	4" x 2"	2-3/16"	5/8" or 3/4"	Roller	Flat	700
<b>5" Ø wheels</b>						
5150-UC-RB	5" x 1-1/2"	1-5/8"	5/8" or 3/4"	Roller	Flat	720
5200-UC-RB	5" x 2"	2-3/16"	5/8" or 3/4"	Roller	Flat	1,050
<b>150mm Ø wheels</b>						
6200-UC[GN]-PBB	150mm x 40mm	52mm	20mm	Precision	Flat	1,500
<b>6" Ø wheels</b>						
6150-UC-RB	6" x 1-1/2"	1-5/8"	5/8" or 3/4"	Roller	Flat	840
6200-UC-RB	6" x 2"	2-3/16"	5/8" or 3/4"	Roller	Flat	1,230
6250S-UC-RB	6" x 2-1/2"	2-3/4"	1" or 1-1/4"	Roller	Flat	1,600
6250L-UC-RB	6" x 2-1/2"	3-1/4"	1" or 1-1/4"	Roller	Flat	1,600
6300-UC-RB	6" x 3"	3-1/4"	1" or 1-1/4"	Roller	Flat	2,050
6300-UC-TB	6" x 3"	3-1/2"	3/4" or 1"	Tapered	Flat	2,050
6400-UC-RB	6" x 4"	4-1/4"	1-1/4" or 1-1/2"	Roller	Flat	5,750
6400-UC-TB	6" x 4"	4-1/2"	1-1/4"	Tapered	Flat	5,750
<b>8" Ø wheels</b>						
8200-UC-RB	8" x 2"	2-3/16"	5/8" or 3/4"	Roller	Flat	1,500
8250S-UC-RB	8" x 2-1/2"	2-3/4"	1" or 1-1/4"	Roller	Flat	1,800
8250L-UC-RB	8" x 2-1/2"	3-1/4"	1" or 1-1/4"	Roller	Flat	1,800
8300-UC-RB	8" x 3"	3-1/4"	1" or 1-1/4"	Roller	Flat	2,500
8300-UC-TB	8" x 3"	3-1/2"	3/4" or 1"	Tapered	Flat	2,500
8400-UC-RB	8" x 4"	4-1/4"	1-1/4" or 1-1/2"	Roller	Flat	5,750
8400-UC-TB	8" x 4"	4-1/2"	1-1/4"	Tapered	Flat	5,750
<b>10" Ø wheels</b>						
10250S-UC-RB	10" x 2-1/2"	2-3/4"	1" or 1-1/4"	Roller	Flat	2,300
10250L-UC-RB	10" x 2-1/2"	3-1/4"	1" or 1-1/4"	Roller	Flat	2,300
10300-UC-RB	10" x 3"	3-1/4"	1" or 1-1/4"	Roller	Flat	2,800
10300-UC-TB	10" x 3"	3-1/2"	3/4" or 1"	Tapered	Flat	2,800
10400-UC-RB	10" x 4"	4-1/4"	1-1/4" or 1-1/2"	Roller	Flat	5,750
10400-UC-TB	10" x 4"	4-1/2"	1-1/4"	Tapered	Flat	5,750

### Options

- [1] 1/2", 5/8" or 3/4" Delrin bearing [1-1/2" and 2" face only]. Substitute 'DEL' for 'RB' in order number. [example: 5200-UC-DEL]
  - [2] 1" or 1-1/4" Delrin bearing [2-1/2" and 3" face only]. Substitute 'DEL' for 'RB' in order number. [example: 10250L-UC-DEL]
  - [3] 5/8" or 3/4" Heavy duty roller bearing [1-1/2" face only]. Substitute 'HRB' for 'RB' in order number. [example: 4150-UC-HRB]
  - [4] 3/4" Heavy duty roller bearing [2" face only]. Substitute 'HRB' for 'RB' in order number. [example: 6200-UC-HRB]
  - [5] 3/4" Brass flanged bearing [1-1/2" and 2" face only]. Substitute 'BF' for 'RB' in order number. [example: 6200-UC-BF]
  - [6] 1" Brass flanged bearing [2-1/2" and 3" face only]. Substitute 'BF' for 'RB' in order number. [example: 12300-UC-BF]
  - [7] 5/8" or 3/4" Vulcanized rubber seals [1-1/2" and 2" face only]. Add 'VS' to order number. [example: 5200C-UC-RB-VS]
  - [8] 1/2" Flanged precision bearing [1-1/2" and 2" face only]. Substitute 'FLPBB' for 'RB' in order number. [example: 8200-UC-FLPBB]
  - [9] 3/4" Flanged precision bearing [2-1/2" Long and 3" face only]. Substitute 'FLPBB' for 'RB' in order number. [example: 12300-UC-FLPBB]
- Note:** All wheels can be supplied with steel or stainless steel spanner bushings. See page 107 for complete listing.

# WHEELS

## Urethane

### UC Series “Urethane on Cast” steel

Our UC Series “Urethane on Cast” wheels are composed of a 95A durometer [nominal] Polyurethane tread formed on a cast steel core. The special bonding process results in a wheel of outstanding shock, load and abrasion resistance. They are much more durable than rubber tread wheels and are highly resistant to most oils, chemicals and solvents. The precision cast core gives it load ratings comparable to steel and the Polyurethane tread is non-marking, relatively quiet, protects the floor surface and has an elastic memory which prevents permanent flat spots.

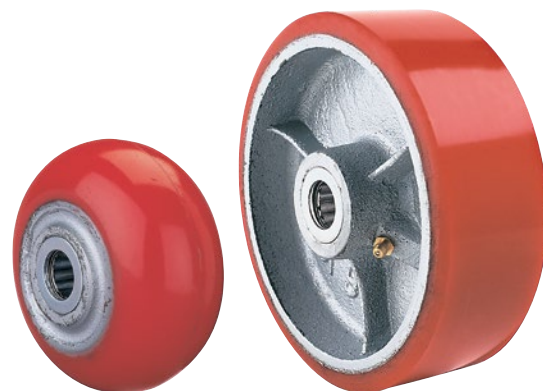

4200C-UC-RB

6200-UC-RB

Order number	Wheel size	Hub length	Bearing size	Bearing type	Tread profile	Load cap.
<b>12" Ø wheels</b>						
12300-UC-RB	12" x 3"	3-1/4"	1" or 1-1/4"	Roller	Flat	3,200
12300-UC-TB	12" x 3"	3-1/2"	3/4" or 1"	Tapered	Flat	3,200
12400-UC-RB	12" x 4"	4-1/4"	1-1/4" or 1-1/2"	Roller	Flat	5,750
12400-UC-TB	12" x 4"	4-1/2"	1-1/4"	Tapered	Flat	5,750
<b>16" Ø wheels</b>						
16300-UC-RB	16" x 3"	3-1/4"	1" or 1-1/4"	Roller	Flat	4,000
16300-UC-TB	16" x 3"	3-1/2"	3/4" or 1"	Tapered	Flat	4,200

### UBA Series urethane on aluminum

These high performance wheels feature a bright red 95A Polyurethane [nominal] tread mechanically and chemically bonded to an aluminum core. The Polyurethane is specially treated to form an extra tough skin designed to resist debris pick-up. These wheels are non-marking and highly resistant to most oils, solvents, fats, greases and many chemicals. The crowned tread profile and standard precision ball bearings make this wheel perfect for towline applications.

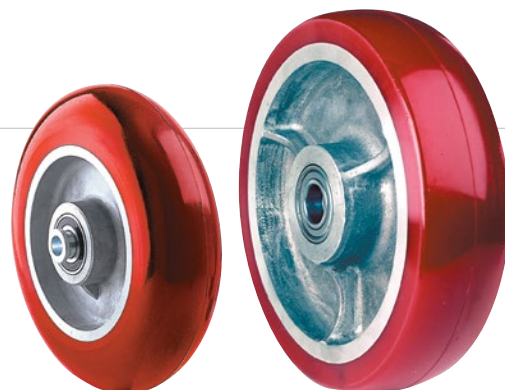

8200C-UBA-PBB

10250SC-UBA-PBB

Order number	Wheel size	Hub length C/W top hats	Axle size	Bearing type	Tread profile	Load cap.
<b>4" Ø wheels</b>						
4200C-UBA-PBB	4" x 2"	2-7/16"	1/2"	Precision Ball	Crowned	900
<b>5" Ø wheels</b>						
5200C-UBA-PBB	5" x 2"	2-7/16"	1/2"	Precision Ball	Crowned	900
<b>6" Ø wheels</b>						
6200C-UBA-PBB	6" x 2"	2-7/16"	1/2"	Precision Ball	Crowned	1,200
6300C-UBA-PBB	6" x 3"	3-1/2"	3/4"	Precision Ball	Crowned	2,100
<b>8" Ø wheels</b>						
8200C-UBA-PBB	8" x 2"	2-7/16"	1/2"	Precision Ball	Crowned	1,500
8300C-UBA-PBB	8" x 3"	3-1/2"	3/4"	Precision Ball	Crowned	2,550
<b>10" Ø wheels</b>						
10250SC-UBA-PBB	10" x 2-1/2"	3" or 3-1/2"	3/4"	Precision Ball	Crowned	3,000

### Options

[1] Stainless steel precision ball bearings. Substitute 'SSPBB' for 'PBB' in order number. [ example: 6200C-UBA-SSPBB ]

**Note:** Custom sizes available. Contact us.

# WHEELS

## Urethane

### MBA Series Megabest urethane on aluminum

Our revolutionary Megabest wheels are a true innovation in Polyurethane wheel designs. The tread is formed of high performance 70A durometer [ nominal ] Polyurethane mechanically and chemically bonded to an aluminum core. The Polyurethane is specially treated to form an extra tough skin designed to resist debris pick-up. The wheel offers the soft cushion ride of rubber with the wear and improved life of an elastomer. In addition to being non-marking, it is also highly resistant to oils, solvents, fats, greases and many chemicals. Standard precision ball bearings make this wheel ideal for towline applications. The smooth cushioned ride make this wheel perfect for use with delicate equipment and instruments. Noise reduction is significant over harder Polyurethane models. This wheel is a winner all the way around!

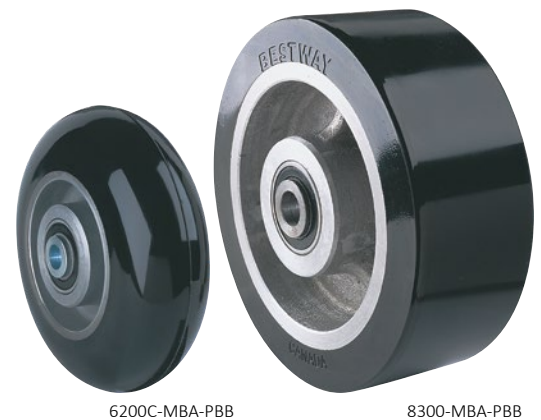

Order number	Wheel size	Hub length C/W top hats	Axle size	Bearing type	Tread profile	Load cap.
<b>4" Ø wheels</b>						
4200C-MBA-PBB	4" x 2"	2-7/16"	1/2"	Precision Ball	Crowned	300
<b>5" Ø wheels</b>						
5200C-MBA-PBB	5" x 2"	2-7/16"	1/2"	Precision Ball	Crowned	300
<b>6" Ø wheels</b>						
6200C-MBA-PBB	6" x 2"	2-7/16"	1/2"	Precision Ball	Crowned	400
6300-MBA-PBB	6" x 3"	3-1/2"	3/4"	Precision Ball	Flat	700
<b>8" Ø wheels</b>						
8200C-MBA-PBB	8" x 2"	2-7/16"	1/2"	Precision Ball	Crowned	500
8300-MBA-PBB	8" x 3"	3-1/2"	3/4"	Precision Ball	Flat	850
<b>10" Ø wheels</b>						
10250SC-MBA-PBB	10" x 2-1/2"	3" or 3-1/2"	3/4"	Precision Ball	Crowned	1,000

### Options

[1] Stainless steel precision ball bearings. Substitute 'SSPBB' for 'PBB' in order number. [ example: 6200C-MBA-SSPBB ]

**Note:** Custom sizes available. Contact us.

### EG Series Elastiglide urethane

Our EG Series Elastiglide wheels feature a hard 70D durometer [ nominal ] Polyurethane tread mechanically and chemically bonded to an aluminum core. This unique system extends the core into the tread thus virtually locking the tread to the core. The half-round tread design will aid in any casters swivelling action. Precision ball bearings are standard, making this wheel excellent for heavy duty applications. The hard Polyurethane tread results in a wheel that rolls extremely well and is highly resistant to oils, solvents, fats, greases and many chemicals.



8200C-EG-PBB

Order number	Wheel size	Hub length C/W Top Hats	Axle size	Bearing type	Tread profile	Load cap.
<b>6" Ø wheels</b>						
6200C-EG-PBB	6" x 2"	2-7/16"	1/2"	Precision Ball	Crowned	1,200
<b>8" Ø wheels</b>						
8200C-EG-PBB	8" x 2"	2-7/16"	1/2"	Precision Ball	Crowned	1,500

### Options

[1] Stainless steel precision ball bearing. Substitute 'SSPBB' for 'PBB' in order number. [ example: 8200C-EG-SSPBB ]

**Note:** Custom sizes available. Contact us.

# WHEELS

## Urethane

### ES Series elastomer [solid]

Continuing research by Bestway has produced this solid Elastomer one-piece caster wheel. Moulded from hard 70D durometer [nominal] Polyurethane to produce a very easy rolling wheel, they have excellent resistance to oils, solvents, fats, greases and many chemicals. This style of wheel eliminates the problem of tread separation that may occur on wheels where the tread is bonded to a separate hub. Being Polyurethane, they have greater abrasion and tear resistance and higher load capacity than rubber, offer superior impact resistance and have an elastic memory to help prevent permanent flat spotting. Designed to operate in temperatures ranging from -20°F to 180°F and available with sealed precision ball bearings suitable for towline applications. The pleasing blue colour makes this wheel stand out from others.



8200C-ES-PBB

8200-ES-PBB

Order number	Wheel size	Hub length	Bearing size	Bearing type	Tread profile	Load cap.
<b>3" Ø wheels</b>						
3150C-ES- HRB	3" x 1-1/2"	1-5/8"	5/8" or 3/4"	Heavy Duty Roller	Crowned	350
<b>4" Ø wheels</b>						
4150C-ES- HRB	4" x 1-1/2"	1-5/8"	5/8" or 3/4"	Heavy Duty Roller	Crowned	400
4200C-ES- HRB	4" x 2"	2-3/16"	3/4"	Heavy Duty Roller	Crowned	800
4200C-ES-PBB	4" x 2"	2-7/16" c/w Top Hats	1/2" Axle	Precision Ball	Crowned	800
<b>5" Ø wheels</b>						
5150C-ES- HRB	5" x 1-1/2"	1-5/8"	5/8" or 3/4"	Heavy Duty Roller	Crowned	500
5200C-ES- HRB	5" x 2"	2-3/16"	3/4"	Heavy Duty Roller	Crowned	1,000
5200C-ES-PBB	5" x 2"	2-7/16" c/w Top Hats	1/2" Axle	Precision Ball	Crowned	1,000
<b>6" Ø wheels</b>						
6200-ES- HRB	6" x 2"	2-3/16"	3/4"	Heavy Duty Roller	Flat	1,200
6200-ES-PBB	6" x 2"	2-7/16" c/w Top Hats	1/2" Axle	Precision Ball	Flat	1,200
6200C-ES- HRB	6" x 2"	2-3/16"	3/4"	Heavy Duty Roller	Crowned	1,200
6200C-ES-PBB	6" x 2"	2-7/16" c/w Top Hats	1/2" Axle	Precision Ball	Crowned	1,200
6250SC-ES-PBB	6" x 2-1/2"	3" or 3-1/2" c/w Top Hats	3/4" Axle	Precision Ball	Crowned	1,500
<b>8" Ø wheels</b>						
8200-ES- HRB	8" x 2"	2-3/16"	3/4"	Heavy Duty Roller	Flat	1,600
8200-ES-PBB	8" x 2"	2-7/16" c/w Top Hats	1/2" Axle	Precision Ball	Flat	1,600
8200C-ES- HRB	8" x 2"	2-3/16"	3/4"	Heavy Duty Roller	Crowned	1,600
8200C-ES-PBB	8" x 2"	2-7/16" c/w Top Hats	1/2" Axle	Precision Ball	Crowned	1,600
8250SC-ES-PBB	8" x 2-1/2"	3" or 3-1/2" c/w Top Hats	3/4" Axle	Precision Ball	Crowned	2,000
<b>10" Ø wheels</b>						
10250SC-ES-PBB	10" x 2-1/2"	3" or 3-1/2" c/w Top Hats	3/4" Axle	Precision Ball	Crowned	2,200

### Options

[1] 1/2", 5/8" or 3/4" Delrin bearing [ 1-1/2" and 2" face only]. Substitute 'DEL' for 'HRB' in order number. [ example: 5200C-ES-DEL ]

[2] 3/4" Stainless roller bearing [ 1-1/2" and 2" face only]. Substitute 'SSRB' for 'HRB' in order number. [ example: 5200C-ES-SSRB ]

[3] Stainless steel precision ball bearing. Substitute 'SSPBB' for 'PBB' in order number. [ example: 8200C-ES-SSPBB ]

[4] 5/8" or 3/4" Vulcanized rubber seals [ 1-1/2" and 2" face only]. Add 'VS' to order number. [ example: 5200C-ES-HRB-VS ]

[5] 1/2" Flanged precision Bearing [ 1-1/2" and 2" face only]. Substitute 'FLPBB' for 'RB' in order number. [ example: 6200-ES-FLPBB ]

**Note:** All wheels can be supplied with steel or stainless steel spanner bushings. See page 107 for complete listing.

Custom sizes available. Contact us.

# WHEELS

## Urethane

### UDU Series hi-capacity urethane on ductile iron

Our unique UDU Series wheels are the best high-capacity Polyurethane tread wheels available on the market. Designed specifically for use with our heavy duty patented double ball kingboltless casters, these wheels feature an extremely hard Polyurethane tread bonded to a core made from our high performance Ductile Iron wheels. The 6" - 12" wheels are covered with 60D black urethane while the 16" wheel uses a stronger and harder 70D blue urethane. The resulting wheel has an extremely high load bearing capacity combined with the floor protective properties of a Polyurethane tread wheel.



8300-UDU-RB

Order number	Wheel size	Hub length	Bearing size	Bearing type	Tread profile	Load cap.
<b>6" Ø wheels</b>						
6300-UDU-RB	6" x 3"	3-1/4"	1" or 1-1/4"	Roller	Flat	5,000
6300-UDU-TB	6" x 3"	3-1/2"	3/4" or 1"	Tapered	Flat	9,000
6400-UDU-RB	6" x 4"	4-1/4"	1-1/4" or 1-1/2"	Roller	Flat	8,000
6400-UDU-TB[HD]	6" x 4"	4-1/2"	1-1/4"	Tapered	Flat	17,000
<b>8" Ø wheels</b>						
8300-UDU-RB	8" x 3"	3-1/4"	1" or 1-1/4"	Roller	Flat	6,000
8300-UDU-TB	8" x 3"	3-1/2"	3/4" or 1"	Tapered	Flat	9,000
8400-UDU-RB	8" x 4"	4-1/4"	1-1/4" or 1-1/2"	Roller	Flat	8,000
8400-UDU-TB[HD]	8" x 4"	4-1/2"	1-1/4"	Tapered	Flat	17,000
<b>10" Ø wheels</b>						
10300-UDU-RB	10" x 3"	3-1/4"	1" or 1-1/4"	Roller	Flat	6,000
10300-UDU-TB	10" x 3"	3-1/2"	3/4" or 1"	Tapered	Flat	9,000
10400-UDU-RB	10" x 4"	4-1/4"	1-1/4" or 1-1/2"	Roller	Flat	8,000
10400-UDU-TB[HD]	10" x 4"	4-1/2"	1-1/4"	Tapered	Flat	17,000
<b>12" Ø wheels</b>						
12300-UDU-RB	12" x 3"	3-1/4"	1" or 1-1/4"	Roller	Flat	6,000
12300-UDU-TB	12" x 3"	3-1/2"	3/4" or 1"	Tapered	Flat	9,000
12400-UDU-RB	12" x 4"	4-1/4"	1-1/4" or 1-1/2"	Roller	Flat	8,000
12400-UDU-TB[HD]	12" x 4"	4-1/2"	1-1/4"	Tapered	Flat	17,000
<b>16" Ø wheels</b>						
16500-UDU-RB	16" x 5"	5-1/4"	1-1/2"	Roller	Flat	10,000
16500-UDU-TB[HD]	16" x 5"	5-1/2"	1-1/4"	Tapered	Flat	25,000

### Options

[1] 1" Brass flanged bearing [3" face only]. Substitute 'BF' for 'RB' in order number. [example: 12300-UDU-BF]

[2] 1" or 1-1/4" Vulcanized rubber seals [3" face only]. Add 'VS' to order number. [example: 6300-UDU-RB-VS]

[3] 1-1/4" or 1-1/2" Vulcanized rubber seals [4" face only]. Add 'VS' to order number. [example: 12400-UDU-RB-VS]

[4] 3/4" Flanged precision bearing [3" face only]. Substitute 'FLPBB' for 'RB' in order number. [example: 10300-UDU-FLPBB]

**Note:** Custom sizes and Polyurethane durometers available. Contact us.



# WHEELS

## Rubber

### MR Series multi-purpose rubber

Bestway's MR Series rubber wheel is the best of both worlds. This advanced design combines the higher load capacity and ease of movement offered by a hard rubber wheel with the cushioning effect of a soft rubber wheel. These wheels are ideal for a wide range of industrial applications.



4150-MR-RB

5150-MR-RB

Order number	Wheel size	Hub length	Bearing size	Bearing type	Tread profile	Load cap.
<b>2" Ø wheels</b>						
2-MR-P	2" x 7/8"	1"	1/4"	Plain	Flat	120
<b>2-1/2" Ø wheels</b>						
25-MR-P	2-1/2" x 1-1/8"	1-3/8"	5/16"	Plain	Flat	150
<b>3" Ø wheels</b>						
3125-MR-P	3" x 1-1/4"	1-1/2"	3/8"	Plain	Flat	210
<b>4" Ø wheels</b>						
4125-MR-P	4" x 1-1/4"	1-1/2"	3/8"	Plain	Flat	300
4150-MR-RB	4" x 1-1/2"	1-5/8"	5/8" or 3/4"	Roller	Flat	400
4200-MR-RB	4" x 2"	2-3/16"	5/8" or 3/4"	Roller	Flat	450
<b>5" Ø wheels</b>						
5138-MR-P	5" x 1-3/8"	1-15/32"	3/8"	Plain	Flat	300
5150-MR-RB	5" x 1-1/2"	1-5/8"	5/8" or 3/4"	Roller	Flat	450
5200-MR-RB	5" x 2"	2-3/16"	5/8" or 3/4"	Roller	Flat	550
<b>6" Ø wheels</b>						
6150-MR-RB	6" x 1-1/2"	1-5/8"	5/8" or 3/4"	Roller	Flat	550
6200-MR-RB	6" x 2"	2-3/16"	5/8" or 3/4"	Roller	Flat	650
<b>8" Ø wheels</b>						
8200-MR-RB	8" x 2"	2-3/16"	5/8" or 3/4"	Roller	Flat	700

### Options

[1] 1/2", 5/8" or 3/4" Delrin bearing. Substitute 'DEL' for 'RB' in order number. [example: 5200-MR-DEL]

[2] [2] 1/2" Flanged precision bearing [1-1/2" and 2" face only]. Substitute 'FLPBB' for 'RB' in order number. [example: 6200-MR-FLPBB]

[3] [3] 5/8" or 3/4" Vulcanized rubber seals. Add 'VS' to order number. [example: 8200-MR-RB-VS]

**Note:** All wheels can be supplied with steel or stainless steel spanner bushings. See page 107 for complete listing.

# WHEELS

## Rubber

### EL Series Eliminator grey non-marking rubber

Our EL Series Eliminator wheel represents the ultimate evolution of the rubber wheel. This excellent wheel combines the advantages of a hard wheel for easy movement and a soft wheel for quietness and floor protection. Featuring a 75A grey non-marking rubber tread permanently bonded to a high-impact polyolefin core, this wheel stands up to weather extremely well and resists most chemicals, oils and acids. Wheels can be steam cleaned and also reject most debris and travellers found on shop floors. Compare our capacities to most competition models and you will see the ELIMINATOR eliminates the need for various wheels.



4125-EL-BB

6200-EL-RB

Order number	Wheel size	Hub length	Bearing size	Bearing type	Tread profile	Load cap.
<b>3" Ø wheels</b>						
3125-EL-RB	3" x 1-1/4"	1-1/2"	3/8"	Ball Bearing	Flat	200
<b>4" Ø wheels</b>						
4125-EL-RB	4" x 1-1/4"	1-1/2"	3/8"	Ball Bearing	Flat	220
4150-EL-RB	4" x 1-1/2"	1-5/8"	5/8" or 3/4"	Roller	Flat	350
4200-EL-RB	4" x 2"	2-3/16"	5/8" or 3/4"	Roller	Flat	600
<b>5" Ø wheels</b>						
5125-EL-RB	5" x 1-1/4"	1-1/2"	3/8"	Ball Bearing	Flat	260
5150-EL-RB	5" x 1-1/2"	1-5/8"	5/8" or 3/4"	Roller	Flat	400
5200-EL-RB	5" x 2"	2-3/16"	5/8" or 3/4"	Roller	Flat	700
<b>6" Ø wheels</b>						
6150-EL-RB	6" x 1-1/2"	1-5/8"	5/8" or 3/4"	Roller	Flat	500
6200-EL-RB	6" x 2"	2-3/16"	5/8" or 3/4"	Roller	Flat	900
6200C-EL-RB	6" x 2"	2-3/16"	5/8" or 3/4"	Roller	Donut	900
<b>8" Ø wheels</b>						
8200-EL-RB	8" x 2"	2-3/16"	5/8" or 3/4"	Roller	Flat	900
8200C-EL-RB	8" x 2"	2-3/16"	5/8" or 3/4"	Roller	Donut	900

### Options

- [1] 1/2" Delrin bearing [ 1-1/4" face only]. Substitute 'DEL' for 'BB' in order number. [ example: 4125-EL-DEL ]
- [2] 1/2", 5/8" or 3/4" Delrin bearing [ 1-1/2" and 2" face only]. Substitute 'DEL' for 'RB' in order number. [ example: 5200-EL-DEL ]
- [3] 1/2" Flanged precision bearing [ 1-1/2" and 2" face only]. Substitute 'FLPBB' for 'RB' in order number. [ example: 8200-EL-FLPBB ]
- [4] 3/4" Stainless steel roller bearing. Substitute 'SSRB' for 'RB' in order number. [ example: 8200-EL-SSRB ]
- [5] 5/8" or 3/4" Vulcanized rubber seals. Add 'VS' to order number. [ example: 6200-EL-RB-VS ]

**Note:** All wheels can be supplied with steel or stainless steel spanner bushings. See page 107 for complete listing.

# WHEELS

## Rubber

### RMC Series hi-capacity rubber moldon

These solid cushion rubber tires permanently moulded onto cast steel wheel centres provide rugged, durable wheels that are widely used on industrial equipment. Their reasonable unit cost contrasted with the high cost of so called “demountable” types make moldons the most economical rubber tires wheels to buy and maintain. Tires average 1” thick and are 70A durometer [ nominal] hardness to increase capacity and ease of movement over softer models.



8200-RMC-RB

Order number	Wheel size	Hub length	Bearing size	Bearing type	Tread profile	Load cap.
<b>4" Ø wheels</b>						
4150-RMC-RB	4" x 1-1/2"	1-5/8"	5/8" or 3/4"	Roller	Flat	500
4200-RMC-RB	4" x 2"	2-3/16"	5/8" or 3/4"	Roller	Flat	700
<b>5" Ø wheels</b>						
5150-RMC-RB	5" x 1-1/2"	1-5/8"	5/8" or 3/4"	Roller	Flat	600
5200-RMC-RB	5" x 2"	2-3/16"	5/8" or 3/4"	Roller	Flat	800
<b>6" Ø wheels</b>						
6150-RMC-RB	6" x 1-1/2"	1-5/8"	5/8" or 3/4"	Roller	Flat	620
6200-RMC-RB	6" x 2"	2-3/16"	5/8" or 3/4"	Roller	Flat	900
6250S-RMC-RB	6" x 2-1/2"	2-3/4"	1" or 1-1/4"	Roller	Flat	1,100
6300-RMC-RB	6" x 3"	3-1/4"	1" or 1-1/4"	Roller	Flat	1,360
<b>8" Ø wheels</b>						
8200-RMC-RB	8" x 2"	2-3/16"	5/8" or 3/4"	Roller	Flat	1,000
8250S-RMC-RB	8" x 2-1/2"	2-3/4"	1" or 1-1/4"	Roller	Flat	1,200
8300-RMC-RB	8" x 3"	3-1/4"	1" or 1-1/4"	Roller	Flat	1,680
<b>10" Ø wheels</b>						
10250S-RMC-RB	10" x 2-1/2"	2-3/4"	1" or 1-1/4"	Roller	Flat	1,500
10300-RMC-RB	10" x 3"	3-1/4"	1" or 1-1/4"	Roller	Flat	2,000
<b>12" Ø wheels</b>						
12300-RMC-RB	12" x 3"	3-1/4"	1" or 1-1/4"	Roller	Flat	2,280
<b>16" Ø wheels</b>						
16300-RMC-RB	16" x 3"	3-1/4"	1" or 1-1/4"	Roller	Flat	2,600

### Options

- [1] 1/2", 5/8" or 3/4" Delrin bearing [ 1-1/2" and 2" face only]. Substitute 'DEL' for 'RB' in order number. [ example: 5200-RMC-DEL ]
- [2] 1" or 1-1/4" Delrin bearing [ 2-1/2" and 3" face only]. Substitute 'DEL' for 'RB' in order number. [ example: 8300-RMC-DEL ]
- [3] 1/2" Flanged precision bearing [ 1-1/2" and 2" face only]. Substitute 'FLPBB' for 'RB' in order number. [ example: 4200-RMC-FLPBB ]
- [4] 5/8" or 3/4" Vulcanized rubber seals [ 1-1/2" and 2" face only]. Add 'VS' to order number. [ example: 8200-RMC-RB-VS ]
- [5] 1" or 1-1/4" Vulcanized rubber seals [ 2-1/2" and 3" face only]. Add 'VS' to order number. [ example: 6250S-RMC-RB-VS ]
- [6] 3/4" Flanged precision bearing [ 2-1/2" Long and 3" face only]. Substitute 'FLPBB' for 'RB' in order number. [ example: 12300-RMC-FLPBB ]

**Note:** All wheels can be supplied with steel or stainless steel bushings. See page 107 for complete listing.

# WHEELS

## Polyolefin

### NL Series “Ny-Lite” polyolefin

Blended from Polyolefins, our NL Series “Ny-Lite” wheels are a hard, non-marking, stain resistant wheel. This material is impervious to water and highly resistant to abrasion, impacts, and chemicals. With a temperature range from -20°F to 180°F, it is steam cleanable to meet a high standard of hygiene. This wheel has a wide range of applications in the food industry and meat processing plants.



3125-NL-P3/8"

Order number	Wheel size	Hub length	Bearing size	Bearing type	Tread profile	Load cap.
<b>3" Ø wheels</b>						
3125-NL-P	3" x 1-1/4"	1-1/2"	3/8" or 1/2"	Plain	Flat	275
3150-NL-RB	3" x 1-1/2"	1-5/8"	5/8" or 3/4"	Roller	Flat	350
3200-NL-RB	3" x 2"	2-3/16"	5/8" or 3/4"	Roller	Flat	400
<b>4" Ø wheels</b>						
4125-NL-P	4" x 1-1/4"	1-1/2"	3/8" or 1/2"	Plain	Flat	300
4150-NL-RB	4" x 1-1/2"	1-5/8"	5/8" or 3/4"	Roller	Flat	420
4200-NL-RB	4" x 2"	2-3/16"	5/8" or 3/4"	Roller	Flat	500
<b>5" Ø wheels</b>						
5125-NL-P	5" x 1-1/4"	1-1/2"	3/8" or 1/2"	Plain	Flat	300
5150-NL-RB	5" x 1-1/2"	1-5/8"	5/8" or 3/4"	Roller	Flat	550
5200-NL-RB	5" x 2"	2-3/16"	5/8" or 3/4"	Roller	Flat	650
<b>6" Ø wheels</b>						
6150-NL-RB	6" x 1-1/2"	1-5/8"	5/8" or 3/4"	Roller	Flat	600
6200-NL-RB	6" x 2"	2-3/16"	5/8" or 3/4"	Roller	Flat	800
<b>8" Ø wheels</b>						
8200-NL-RB	8" x 2"	2-3/16"	5/8" or 3/4"	Roller	Flat	1,000

### Options

- [1] 1/2", 5/8" or 3/4" Delrin bearing. Substitute 'DEL' for 'RB' in order number. [example: 5200-NL-DEL]
- [2] 1/2" Flanged precision bearing [1-1/2" and 2" face only]. Substitute 'FLPBB' for 'RB' in order number. [example: 5200-NL-FLPBB]
- [3] 3/4" Brass flanged bearing. Substitute 'BF' for 'RB' in order number. [example: 6200-NL-BF]
- [4] 3/4" Stainless steel roller bearing. Substitute 'SSRB' for 'RB' in order number. [example: 5150-NL-SSRB]
- [5] 5/8" or 3/4" Vulcanized rubber seals. Add 'VS' to order number. [example: 8200-NL-RB-VS]

**Note:** All wheels can be supplied with steel or stainless steel spanner bushings. See page 107 for complete listing.

# WHEELS

## Polyolefin

### WNL Series white polyolefin

This wheel is made from the same high-performance Polyolefins as our NL Series wheels but is produced in a white colour. This makes it ideal for steam clean, cart wash and clean room environments [particularly the food industry] so dirt can clearly be seen for proper cleaning.

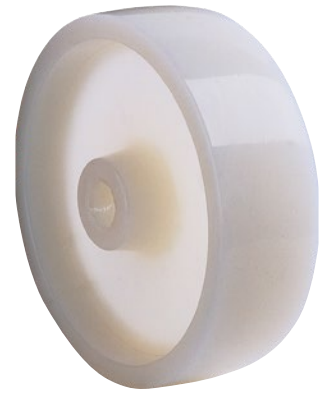

5125-WNL-P

Order number	Wheel size	Hub length	Bearing size	Bearing type	Tread profile	Load cap.
<b>2" Ø wheels</b>						
2-WNL-P	2" x 3/4"	1"	1/4"	Plain	Flat	100
<b>3" Ø wheels</b>						
3125-WNL-P	3" x 1-1/4"	1-1/2"	3/8" or 1/2"	Plain	Flat	275
<b>4" Ø wheels</b>						
4125-WNL-P	4" x 1-1/4"	1-1/2"	3/8" or 1/2"	Plain	Flat	300
<b>5" Ø wheels</b>						
5125-WNL-P	5" x 1-1/4"	1-1/2"	3/8" or 1/2"	Plain	Flat	300

**Note:** All wheels can be supplied with steel or stainless steel spanner bushings. See page 107 for complete listing.

# WHEELS

## Nylon

### NY Series virgin white nylon

These wheels, moulded from #6 Nylon, are ideal for steam cleaning and wet conditions. Their shiny white colour instantly shows dirt missed in cleaning. This material has exceptional wear and abrasion resistance, high impact strength, is lightweight, has greater load bearing capacity than Polyolefin models, is highly resistant to organic solvents and most chemicals, and can operate at temperatures from -40°F to 210°F. Perfect for use in food processing, poultry and meat packing plants.



6200-NY-RB

8200-NY-RB

Order number	Wheel size	Hub length	Bearing size	Bearing type	Tread profile	Load cap.
<b>3" Ø wheels</b>						
3150-NY-RB	3" x 1-1/2"	1-5/8"	5/8" or 3/4"	Roller	Flat	700
3200-NY-RB	3" x 2"	2-3/16"	5/8" or 3/4"	Roller	Flat	800
<b>80mm Ø wheels</b>						
080-NY-P	80mm x 30mm	40mm	12mm	Plain	Flat	220
<b>4" Ø wheels</b>						
4150-NY-RB	4" x 1-1/2"	1-5/8"	5/8" or 3/4"	Roller	Flat	600
4200-NY-RB	4" x 2"	2-3/16"	5/8" or 3/4"	Roller	Flat	800
<b>100mm Ø wheels</b>						
100-NY-P	100mm x 35mm	40mm	12mm	Plain	Flat	300
<b>5" Ø wheels</b>						
5150-NY-RB	5" x 1-1/2"	1-5/8"	5/8" or 3/4"	Roller	Flat	600
5200-NY-RB	5" x 2"	2-3/16"	5/8" or 3/4"	Roller	Flat	1,000
<b>125mm Ø wheels</b>						
125-NY-P	125mm x 40mm	46mm	15mm	Plain	Flat	350
<b>6" Ø wheels</b>						
6150-NY-RB	6" x 1-1/2"	1-5/8"	5/8" or 3/4"	Roller	Flat	800
6200-NY-RB	6" x 2"	2-3/16"	5/8" or 3/4"	Roller	Flat	1,200
<b>8" Ø wheels</b>						
8200-NY-P 20mm	8" x 2"	2-3/8"	20mm	Plain	Flat	1,000
8200-NY-RB 20mm	8" x 2"	2-3/8"	20mm	Roller	Flat	1,000
8200-NY-RB	8" x 2"	2-3/16"	5/8" or 3/4"	Roller	Flat	1,200

### Options

- [1] 1/2", 5/8" or 3/4" Delrin bearing. Substitute 'DEL' for 'RB' in order number. [example: 6200-NY-DEL]
- [2] 1/2" Flanged precision bearing [2" face only]. Substitute 'FLPBB' for 'RB' in order number. [example: 3200-NY-FLPBB]
- [3] 3/4" Brass flanged bearing. Substitute 'BF' for 'RB' in order number. [example: 8200-NY-BF]
- [4] 3/4" Stainless steel roller bearing. Substitute 'SSRB' for 'RB' in order number. [example: 6200-NY-SSRB]
- [5] 5/8" or 3/4" Vulcanized rubber seals. Add 'VS' to order number. [example: 3200-NY-RB-VS]

**Note:** All wheels can be supplied with steel or stainless steel spanner bushings. See page 107 for complete listing.

## Nylon vs. Polyolefin wheels

The advantage of a white wheel is that its bright white colour readily shows up any dirt deposited on its surface. This is ideal for washdown and steam clean applications [particularly in the food industry] where it is important to ensure that carts are totally clean.

White wheels are available in both polyolefin [WNL Series] and nylon [NY Series] materials. Which is best for you? Both polyolefin and nylon are highly resistant to most chemicals, but overall nylon is a much higher quality material. Not only does nylon have a greater load bearing capacity, but it is more resistant to impact, abrasion and wear. It also has a higher tolerance to heat [210°F for nylon vs. 180°F for polyolefin].

# WHEELS

## PAL Series pallet

These heavy duty Pallet Wheels are constructed of a hard 70D durometer [nominal] Polyurethane tread, mechanically bonded to a light and strong one-piece aluminum core. Precision ball bearings are standard to facilitate start-up.

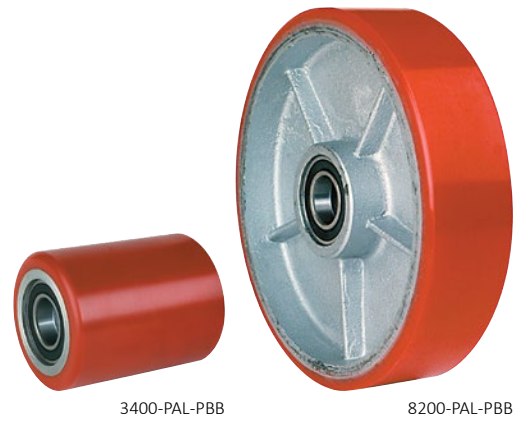

Order number	Wheel size	Hub length	Bearing size	Bearing type	Tread profile	Load cap.
<b>3" Ø wheels</b>						
3275-PAL-PBB	3" x 2-3/4"	2-3/4"	20 or 25mm	Precision Ball	Flat	2,000
3350-PAL-PBB	3" x 3-1/2"	3-1/2"	20 or 25mm	Precision Ball	Flat	2,000
3375-PAL-PBB	3" x 3-3/4"	3-3/4"	20 or 25mm	Precision Ball	Flat	2,000
3400-PAL-PBB	3" x 4"	4"	20 or 25mm	Precision Ball	Flat	2,000
<b>3-1/4" Ø wheels</b>						
3254-PAL-PBB	3-1/4" x 4"	4"	20 or 25mm	Precision Ball	Flat	2,000
<b>8" Ø wheels</b>						
8200-PAL-PBB	8" x 2"	2"	20 or 25mm	Precision Ball	Flat	1,500

## Options

[1] Can be shipped without bearings [Bore Less Bearing]. Substitute 'BLB' for 'PBB' in order number. [example: 3350-PAL-BLB]

**Notes:** Other bearing sizes [including Imperial sizes] may be available. Contact us.  
Custom sizes available. Contact us.





# REPLACEMENT PARTS

Bearings	104
Top hat bushings	105
Bearings, washers and seals	106
Spanner bushings	107
Axle kits	108

# REPLACEMENT PARTS

## Bearings

### Roller bearings

Roller bearings offer the best compromise between capacity, rollability and value in a bearing. Constructed with a series of hardened steel rollers encased in a split metal sleeve cover. Our standard bearing type. Made in North America.



Order number	ID	OD	Length	Retainer washers			Thrust washer
				Steel	Nylon	Double Nylon	
RB-58150	5/8"	1-3/16"	1-3/8"	RW-34136	NW-34136	DW-34136	TW-58
RB-34150	3/4"	1-3/16"	1-3/8"	RW-34136	NW-34136	DW-34136	TW-34
RB-34178	3/4"	1-3/16"	1-7/8"	RW-34136	NW-34136	DW-34136	TW-34
RB-58200	5/8"	1-3/16"	2"	RW-34136	NW-34136	DW-34136	TW-58
RB-34200	3/4"	1-3/16"	2"	RW-34136	NW-34136	DW-34136	TW-34
RB-10200	1"	1-7/16"	2"	RW-10176			TW-10
RB-10250	1"	1-15/16"	2-1/2"	RW-14115			TW-10
RB-14250	1-1/4"	1-15/16"	2-1/2"	RW-14115			TW-14
RB-10300	1"	1-15/16"	3"	RW-14115			TW-10
RB-14300	1-1/4"	1-15/16"	3"	RW-14115			TW-14
RB-14400	1-1/4"	2-7/16"	4"	RW-14276			TW-14
RB-15400	1-1/2"	2-7/16"	4"	RW-15276			TW-15
RB-15500	1-1/2"	2-7/16"	5"	RW-15276			TW-15

### One-piece heavy duty roller bearings

An improved version of our standard roller bearing featuring a solid outer sleeve for simplified installation and improved grease retention. Made in North America.



Order number	ID	OD	Length
HRB-58150	5/8"	1-3/16"	1-3/8"
HRB-34150	3/4"	1-3/16"	1-3/8"
HRB-34178	3/4"	1-3/16"	1-7/8"

### Stainless steel roller bearings [all stainless]

A fully stainless steel version of our standard roller bearing. Provides higher capacity and improved rollability over Delrin Bearings.



Order number	ID	OD	Length
SSRB-34150	3/4"	1-3/16"	1-3/8"
SSRB-34200	3/4"	1-3/16"	2"
SSRB-10300	1"	1-15/16"	3"

### One-piece Delrin bearings

A one-piece insert bearing constructed from Delrin material. Our standard bearing for use with stainless steel casters where a cam style brake is used.



Order number	ID	OD	Length
DB-12150	1/2"	1-3/16"	1-5/8"
DB-58150	5/8"	1-3/16"	1-5/8"
DB-34150	3/4"	1-3/16"	1-5/8"
DB-12200	1/2"	1-3/16"	2-1/8"
DB-58200	5/8"	1-3/16"	2-1/8"
DB-34200	3/4"	1-3/16"	2-1/8"
DB-10200	1"	1-7/16"	2"
DB-10125	1"	1-15/16"	1-1/4"
DB-14125	1-1/4"	1-15/16"	1-1/4"
DB-10150	1"	1-15/16"	1-1/2"
DB-14150	1-1/4"	1-15/16"	1-1/2"

## Selecting the right bearing

Finding the right caster for your application involves more than just picking the fork and wheel types. The bearing you select for your wheel has a great impact on the overall performance of your caster.

- For improved rollability select flanged ball bearings, precision ball bearings, or tapered roller bearings.
- For increased capacity select tapered roller bearings or precision ball bearings.
- Wet conditions call for Delrin bearings, stainless roller bearings or stainless precision ball bearings.
- High heat applications require either flanged brass bearings or Hi-Lex spanner bushings.
- Precision ball bearings or tapered roller bearings are required for towline applications.

Remember, whatever bearing you choose, proper regular maintenance is required to keep it working!

# REPLACEMENT PARTS

## Bearings and top hat bushings

### Flanged roller bearings

Flanged roller bearings are a higher capacity alternative to flanged ball bearings such as those found on our pneumatic and semi-pneumatic wheels. Made in North America.



Order number	ID	OD	Length
RF-58138	5/8"	1-3/8"	1"
RF-34138	3/4"	1-3/8"	1"

### Flanged Delrin bearings

Delrin is a high-strength, wear resistant material with a low coefficient of friction. This combined with good chemical resistance and low moisture absorption make it ideal for use as a wheel bearing. This is our standard stainless bearing. One-piece Delrin bearings are required when a cam-style brake [BR] is used.



Order number	ID	OD	Length
DF-12118	1/2"	1-1/8"	1/2"
DF-12136	1/2"	1-3/16"	11/16"
DF-58136	5/8"	1-3/16"	11/16"
DF-34136	3/4"	1-3/16"	11/16"
DF-12138	1/2"	1-3/8"	5/8"
DF-58138	5/8"	1-3/8"	5/8"
DF-34138	3/4"	1-3/8"	5/8"

### Precision ball bearings

Our fully sealed precision ball bearings [available in both steel and stainless steel] provide both greatly increased rollability and higher capacity over roller bearings. PBB's are ideal for towline applications.



Order number	ID	OD	Seal type
PBB-6203-2RS	17mm	40mm	Rubber
PBB-6204-2RS	20mm	47mm	Rubber
PBB-6205-2RS	25mm	52mm	Rubber

### Stainless precision ball bearings

Order number	ID	OD	Seal type
SSPBB-6203-2RS	17mm	40mm	Rubber
SSPBB-6205-2RS	25mm	52mm	Rubber

### Flanged brass bearings

Flanged brass bearings are ideal for high-heat or corrosive environments or for wet applications where Delrin bearings are inappropriate. Made in North America.



Order number	ID	OD	Length
BF-34136	3/4"	1-3/16"	5/8"
BF-10115	1"	1-15/16"	1-3/8"

### Flanged ball bearings

Flanged ball bearings provide improved rollability over standard roller bearings however load capacity is reduced.



Order number	ID	OD	Length
BB-38118	3/8"	1-1/8"	13/16"
FLPBB-12136L*	1/2"	1-3/16"	1-7/32"
FLPBB-12136S	1/2"	1-3/16"	15/16"
BB-12138	1/2"	1-3/8"	1/2"
BB-58138	5/8"	1-3/8"	1/2"
BB-34138	3/4"	1-3/8"	1/2"
FLPBB-34156	3/4"	1-15/16"	1-3/4"

Note: \*FLPBB-12136L also available in stainless steel.

### Top hat bushings

Our precision machined top hat spacers are designed for use with precision ball bearings. Note: Require 2 per wheel.



Order number	ID x OD	Length
TH-56	5/16" x 17mm	27/32"
TH-38	3/8" x 17mm	27/32"
TH-12	1/2" x 17mm	1-7/32"
TH-34S	3/4" x 25mm	1-1/2"
TH-34L	3/4" x 25mm	1-3/4"
TH-34XL	3/4" x 25mm	1-3/4"

### Stainless top hat bushings

Order number	ID x OD	Length
SSTH-38	3/8" x 17mm	27/32"
SSTH-12	1/2" x 17mm	1-7/32"
SSTH-34S	3/4" x 25mm	1-1/2"
SSTH-34L	3/4" x 25mm	1-3/4"
SSTH-34XL	3/4" x 25mm	1-3/4"

# REPLACEMENT PARTS

## Bearings, washers and seals

Tapered roller bearings offer both much higher load bearing capacity and improved rollability over standard roller bearings. They are suitable for towline applications. **Note: 2 per wheel are required.**

### Tapered roller bearings

Order number	ID	Typical installation
TB-34	3/4"	Most 1-15/16" Bore Wheels
TB-10	1"	Most 1-15/16" Bore Wheels
TB-14	1-1/4"	Most 2-7/16" Bore Wheels
TB[HD]-14	1-1/4"	Most 2-7/16" Bore Wheels
TB-15	1-1/2"	Most 2-7/16" Bore Wheels
TB-20	2"	Most 2-7/16" Bore Wheels

### Steel retainer washers

Retainer washers are used to firmly hold roller bearings in place in the wheel. They are available in steel, nylon or stainless steel.



Order number	ID	OD
RW-12116	1/2"	1-1/16"
RW-34136	3/4"	1-3/16"
RW-10176	1"	1-7/16"
RW-14115	1-1/4"	1-15/16"
RW-14276	1-1/4"	2-7/16"
RW-15276	1-1/2"	2-7/16"

### Stainless steel retainer washers

Order number	ID	OD
SSRW-34136	3/4"	1-3/16"
SSRW-14115	1"	1-15/16"

### Steel thrust washers

Order number	ID
TW-12	1/2"
TW-58	5/8"
TW-34	3/4"
TW-10	1"
TW-14	1-1/4"
TW-15	1-1/2"

### Stainless steel thrust washers

Order number	ID
SSTW-12	1/2"
SSTW-34	3/4"
SSTW-10	1"

## Washers and top hats – selection and installation guide

Different bearing types require different combinations of washers to ensure proper operation of the wheel. Here is a brief guide:

- Retainer washers are used to “retain” or hold in place roller bearings [standard, one-piece and stainless steel].
- Thrust washers are used in conjunction with retainer washers to keep the caster fork legs from compressing against the side of the wheel.
- Double nylon washers are a combination retainer washer and thrust washer together in one piece.
- Flanged bearings [Delrin, flanged brass, flanged roller and flanged ball] and tapered roller bearings do not require washers to be installed.
- Casters using cam style pedal brakes [BR] must use separate retainer and thrust washers [rather than double nylon washers] to operate.
- Precision ball bearings require the use of top hat spacers.

### Vulca seals

Vulca seals are a rubberised version of our standard steel retainer washers and are used to provide a seal for our standard roller bearings.



Order number	ID	OD	Thickness
VS-34136	3/4"	1-3/16"	3/32"
VS-58136	5/8"	1-3/16"	3/32"
VS-10115	1"	1-15/16"	1/8"
VS-14115	1-1/4"	1-15/16"	1/8"
VS-14276	1-1/4"	2-7/16"	1/8"
VS-15276	1-1/2"	2-7/16"	1/8"

### Head seals

Head seals are soft gaskets used to seal the raceways on a caster to prevent infiltration of debris.



Order number	Series used with
HS-BW	BW, RT, SSBW and SSRT Series
HS-HD	HD, LH, SSHD and SSLH Series
HS-LD	LD and SSLD Series
HS-LS	LE, LS, SSLE and SSLS Series

### Nylon retainer washers

Order number	ID	OD
NW-12116	1/2"	1-1/16"
NW-34136	3/4"	1-3/16"

### Double nylon retainer washers

Order number	ID	OD
DW-34136	3/4"	1-3/16"

# REPLACEMENT PARTS

## Spanner bushings

### Steel spanner bushings

Spanner bushings are used to “span” the distance between the legs of the fork. The spanner is locked in place allowing the bearing to turn freely. Precision machined and cross-drilled to allow for lubrication of the wheel bearing.

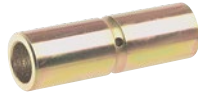

Order number	ID	OD	Length
SB-5638112	5/16"	3/8"	1-1/2"
SB-5638196	5/16"	3/8"	1-9/16"
SB-5612196	5/16"	1/2"	1-9/16"
SB-5658111	5/16"	5/8"	1-11/16"
SB-5612M178	5/16"	12mm	1-7/8"
SB-5658178	5/16"	5/8"	1-7/8"
SB-3812196	3/8"	1/2"	1-9/16"
SB-3812178	3/8"	1/2"	1-7/8"
SB-3858111	3/8"	5/8"	1-11/16"
SB-3858178	3/8"	5/8"	1-7/8"
SB-1258178	1/2"	5/8"	1-7/8"
SB-1258276	1/2"	5/8"	2-7/16"
SB-1234178	1/2"	3/4"	1-7/8"
SB-1234276	1/2"	3/4"	2-7/16"
SB-1210300	1/2"	1"	3"
SB-1210312	1/2"	1"	3-1/2"
SB-5834178	5/8"	3/4"	1-7/8"
SB-5834276	5/8"	3/4"	2-7/16"
SB-5810300	5/8"	1"	3"
SB-5810312	5/8"	1"	3-1/2"
SB-3410300	3/4"	1"	3"
SB-3410312	3/4"	1"	3-1/2"
SB-1014312	1"	1-1/4"	3-1/2"
SB-1014412	1"	1-1/4"	4-1/2"
SB-1415312	1-1/4"	1-1/2"	3-1/2"
SB-1415412	1-1/4"	1-1/2"	4-1/2"

## Custom components

Bestway has it's own in-house machine shop where we can quickly manufacture any custom replacement part or component you may require.

If you require a component that is not listed on these pages, give us the specifications and we can make it for you. As with all of our custom specials, we offer speedy delivery and unbeatable pricing. There is no minimum order quantity required.

Here's just a sample of the custom products we can produce for you:

- Axle kits [plain and grease]
- Spanner bushings
- Top hat spacers for PBB's
- Flanged metal bearings

We can machine your product in the material of your choice [steel, stainless steel, brass, bronze, Delrin]. We can also source non-standard bearing types and sizes to suit your specific application needs.

### Steel spanner bushings

A fully stainless steel version of our standard steel spanner bushing.



Order number	ID	OD	Length
SSB-5612M111	5/16"	12mm	1-11/16"
SSB-5612196	5/16"	1/2"	1-9/16"
SSB-5658111	5/16"	5/8"	1-11/16"
SSB-5634111	5/16"	3/4"	1-11/16"
SSB-5612M178	5/16"	12mm	1-7/8"
SSB-3812196	3/8"	1/2"	1-9/16"
SSB-3815M178	3/8"	15mm	1-7/8"
SSB-3858111	3/8"	5/8"	1-11/16"
SSB-3858178	3/8"	5/8"	1-7/8"
SSB-3834111	3/8"	3/4"	1-11/16"
SSB-3834178	3/8"	3/4"	1-7/8"
SSB-1234178	1/2"	3/4"	1-7/8"
SSB-1234276	1/2"	3/4"	2-7/16"
SSB-3410300	3/4"	1"	3"
SSB-3410312	3/4"	1"	3-1/2"

### Hi-Lex spanner bushings

These special spanner bushings are designed to allow wheels to turn through the expansion and contraction often experienced in high-heat applications that cause other bearings to squeak and bind. They are intended for use with our special high-temp monolithic wheels [HTM Series].

Order number	ID	OD	Length
HL-56	5/16"	12mm	1-5/8"
HL-38	3/8"	15mm	1-7/8"

# REPLACEMENT PARTS - BEARINGS

## Axle kits

### Grease axle kits

Grease axles are hollow axles that are fitted with a grease nipple to allow periodic lubrication of the wheel bearing.



Order number	Diameter	Length
GAK-56214	5/16"	2-1/4"
GAK-56212	5/16"	2-1/2"
GAK-38214	3/8"	2-1/4"
GAK-38212	3/8"	2-1/2"
GAK-38300	3/8"	3"
GAK-12300	1/2"	3"
GAK-12312	1/2"	3-1/2"
GAK-12400	1/2"	4"
GAK-12412	1/2"	4-1/2"
GAK-12500	1/2"	5"
GAK-12512	1/2"	5-1/2"
GAK-12612	1/2"	6-1/2"
GAK-34412	3/4"	4-1/2"
GAK-34500	3/4"	5"
GAK-34512	3/4"	5-1/2"
GAK-34900	3/4"	9"
GAK-10512	1"	5-1/2"
GAK-14612	1-1/4"	6-1/2"
GAK-14700	1-1/4"	7"
GAK-14130	1-1/4"	13"

### Stainless steel plain axle

A fully stainless steel version of our standard plain axles.

Order number	Diameter	Length
SSAK-56214	5/16"	2-1/4"
SSAK-38214	3/8"	2-1/4"
SSAK-38212	3/8"	2-1/2"
SSAK-12300	1/2"	3"
SSAK-12312	1/2"	3-1/2"
SSAK-34412	3/4"	4-1/2"
SSAK-34500	3/4"	5"

### Stainless steel grease axle

A fully stainless steel version of our standard grease axles.



Order number	Diameter	Length
SSGAK-56214	5/16"	2-1/4"
SSGAK-38214	3/8"	2-1/4"
SSGAK-38212	3/8"	2-1/2"
SSGAK-12300	1/2"	3"
SSGAK-12312	1/2"	3-1/2"
SSGAK-34412	3/4"	4-1/2"
SSGAK-34500	3/4"	5"

### Plain axle kits

Plain axles [ without grease fittings ] are used with spanners and bearings that do not require lubrication.



Order number	Diameter	Length
AK-25112	1/4"	1-1/2"
AK-25134	1/4"	1-3/4"
AK-25200	1/4"	2"
AK-56200	5/16"	2"
AK-56214	5/16"	2-1/4"
AK-56212	5/16"	2-1/2"
AK-38214	3/8"	2-1/4"
AK-38212	3/8"	2-1/2"
AK-38300	3/8"	3"
AK-12300	1/2"	3"
AK-12312	1/2"	3-1/2"
AK-12400	1/2"	4"
AK-12412	1/2"	4-1/2"
AK-12500	1/2"	5"
AK-12512	1/2"	5-1/2"
AK-12612	1/2"	6-1/2"
AK-34412	3/4"	4-1/2"
AK-34500	3/4"	5"
AK-34512	3/4"	5-1/2"
AK-34900	3/4"	9"
AK-10512	1"	5-1/2"
AK-14612	1-1/4"	6-1/2"
AK-14700	1-1/4"	7"
AK-14100	1-1/4"	10"
AK-14130	1-1/4"	13"

## Choosing the right axle kit

There are several things to consider when selecting an axle kit.

- The diameter of the axle is determined by the axle hole size of the caster being used.
- The length of the axle is determined by the fork leg spacing of the caster used. On some light duty casters a slightly longer axle may be required if a side pedal brake is installed.
- Stainless steel material should be used with all stainless steel casters regardless of bearing type or material.
- Plain axles should be used where there is no requirement to lubricate the wheel bearing [ i.e. plain bore, flanged ball bearings, flanged roller bearings and precision ball bearings ].
- Grease axles are used where periodic lubrication of the wheel bearing is required [ i.e. roller bearings, Delrin bearings, one-piece heavy duty roller bearings, stainless steel roller bearings and tapered roller bearings ].





**Bestway Casters & Wheels Ltd.**

42 Cardico Dr.  
Stouffville, ON L4A 2G5  
T 905.888.5162  
F 905.888.5167  
[sales@bestwaycasters.com](mailto:sales@bestwaycasters.com)

**Québec location**

9270 Henri-Bourassa Ouest  
St. Laurent, QC H4S 1L5  
T 514.855.1234  
F 905.888.5167  
[ventes@bestwaycasters.com](mailto:ventes@bestwaycasters.com)

**[www.bestwaycasters.com](http://www.bestwaycasters.com)**