



AT Series Vane Pumps

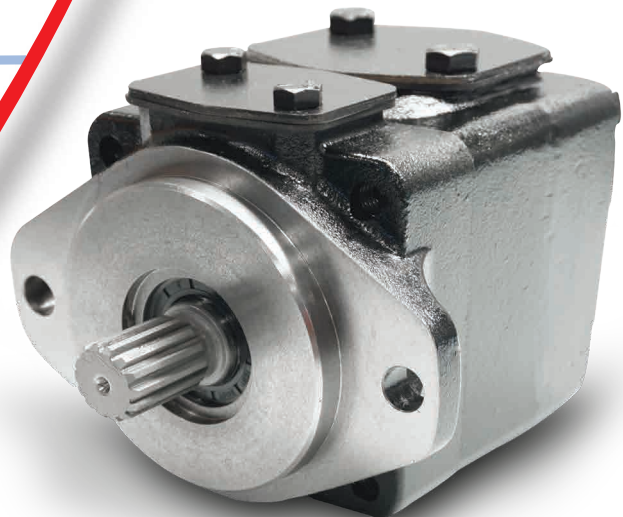
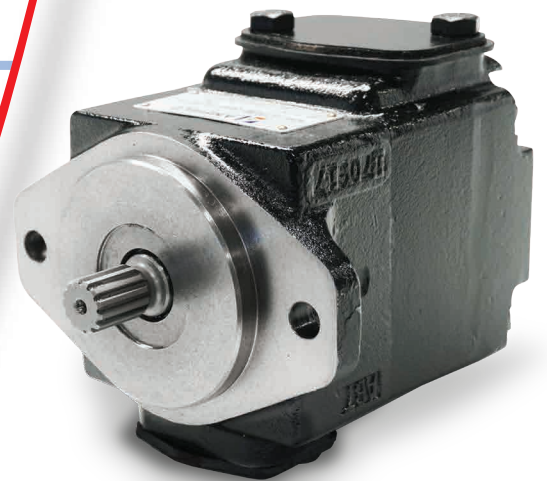
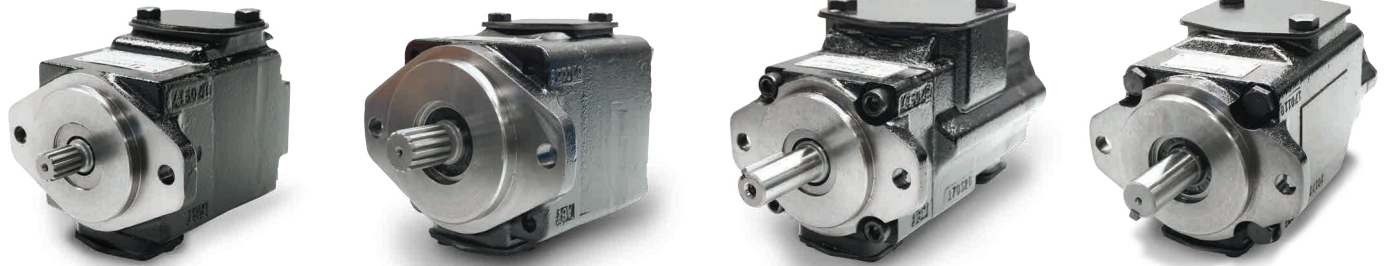

Table of Contents



General Information / Technical Data	4-5
AT6CM	Operating Characteristics.....6 Dimensions & Ordering Code.....7
AT6DM	Operating Characteristics.....8 Dimensions & Ordering Code.....9
AT6EM	Operating Characteristics.....10 Dimensions & Ordering Code.....11
AT6CCM	Operating Characteristics.....12 Dimensions & Ordering Code.....13
AT6DCM	Operating Characteristics.....14 Dimensions & Ordering Code.....15
AT6EDM	Operating Characteristics.....16 Dimensions & Ordering Code.....17
AT6DCCM	Operating Characteristics.....18 Dimensions & Ordering Code.....19
AT6EDCS	Operating Characteristics.....20 Dimensions & Ordering Code.....21
Porting Diagrams	22
Cartridge Kits	23



AT Series Vane Pumps

INTRODUCTION

Anfield's vane pump is designed with high pressure capabilities and provides extended life at reduced pressure. The combination of different cartridges in double and triple pumps allows low flow at high pressure and high flow at lower pressure. This is the intelligent way to optimize your circuit design. The pump also allows a very fast pressure cycle change with a very precise flow repeatability.



FEATURES AND BENEFITS

- Increased Efficiency
- Reduced Noise Level
- Easy Installation

MARKETS

- Mobile
- Agriculture
- Marine
- Military

GENERAL CHARACTERISTICS

Model #	Mounting Standard	Weight without connector and bracket		Moment of inertia kgm ² x 10 ⁻⁴	SAE 4 bolts J518c - ISO/DIS 6162-1			
		kg	lbs		Suction	Pressure		
AT6CM	SAE J744c ISO/3019-1 SAE B	16	35	7.5	1-1/2"	1"		
AT6DM	SAE J744c ISO/3019-1 SAE C	24	53	23.3	2"	1-1/4"		
AT6EM		43	95	51.5	3"	1-1/2"		
AT6CCM	SAE J744c ISO/3019-1 SAE B	26	57	14.9	2-1/2" or 3"	P1	P2	
						1"	1" or 3/4"	
AT6DCM	SAE J744c ISO/3019-1 SAE C	37	82	30.4	3"	1-1/4"	1"	
AT6ECM		55	121	58.0	3-1/2"	1-1/2"	1"	
AT6EDM		66	146	73.4	4"	1-1/2"	1-1/4"	
AT6DCCM		61	134	37.3	4"	P1	P2	P3
						1-1/4"	1"	1" or 3/4"
AT6EDCS	SAE "E"	100	220	80.2	4"	1-1/2"	1-1/4"	1" or 3/4"

AT Series Vane Pumps



TECHNICAL DATA

Series	Size	Theoretical Displacement Vi	Min Speed	Max Speed		Maximum Pressure													
				cc	rpm	HF-0, HF-1, HF-2	HF-3, HF-4, HF-5	HF-0, HF-2				HF-1, HF-4, HF-5				HF-3			
								Int.		Cont.		Int.		Con		Int.		Cont.	
								bar	psi	bar	psi	bar	psi	bar	psi	bar	psi	bar	psi
AT6C	B03	10.8	600	2800	1800	275	3989	240	3481	210	3046	175	2538	175	2538	140	2031		
	B05	17.2	600	2800	1800	275	3989	240	3481	210	3046	175	2538	175	2538	140	2031		
	B06	21.3	600	2800	1800	275	3989	240	3481	210	3046	175	2538	175	2538	140	2031		
	B08	26.4	600	2800	1800	275	3989	240	3481	210	3046	175	2538	175	2538	140	2031		
	B10	34.1	600	2800	1800	275	3989	240	3481	210	3046	175	2538	175	2538	140	2031		
	B12	37.1	600	2800	1800	275	3989	240	3481	210	3046	175	2538	175	2538	140	2031		
	B14	46.0	600	2800	1800	275	3989	240	3481	210	3046	175	2538	175	2538	140	2031		
	B17	58.3	600	2800	1800	275	3989	240	3481	210	3046	175	2538	175	2538	140	2031		
	B30	63.8	600	2800	1800	275	3989	240	3481	210	3046	175	2538	175	2538	140	2031		
	B22	70.3	600	2800	1800	275	3989	240	3481	210	3046	175	2538	175	2538	140	2031		
	B25	79.3	600	2500	1800	275	3989	240	3481	210	3046	175	2538	175	2538	140	2031		
	B28	88.8	600	2500	1800	210	3046	160	2321	210	3046	160	2321	175	2538	140	2031		
B31	100.0	600	2500	1800	210	3046	160	2321	210	3046	160	2321	175	2538	140	2031			
AT6D	B14	47.6	600	2500	1800	240	3481	210	3046	210	3046	175	2538	175	2538	140	2031		
	B17	58.2	600	2500	1800	240	3481	210	3046	210	3046	175	2538	175	2538	140	2031		
	B20	66.0	600	2500	1800	240	3481	210	3046	210	3046	175	2538	175	2538	140	2031		
	B24	79.5	600	2500	1800	240	3481	210	3046	210	3046	175	2538	175	2538	140	2031		
	B28	89.7	600	2500	1800	240	3481	210	3046	210	3046	175	2538	175	2538	140	2031		
	B31	98.3	600	2500	1800	240	3481	210	3046	210	3046	175	2538	175	2538	140	2031		
	B35	111.0	600	2500	1800	240	3481	210	3046	210	3046	175	2538	175	2538	140	2031		
	B38	120.3	600	2500	1800	240	3481	210	3046	210	3046	175	2538	175	2538	140	2031		
	B42	136.0	600	2200	1800	240	3481	210	3046	210	3046	175	2538	175	2538	140	2031		
	B45	145.7	600	2200	1800	240	3481	210	3046	210	3046	175	2538	175	2538	140	2031		
AT6E	B50	158.0	600	2200	1800	240	3481	160	2321	210	3046	160	2321	175	2538	140	2031		
	B42	132.3	600	2200	1800	240	3481	210	3046	210	3046	175	2538	175	2538	140	2031		
	B45	142.4	600	2200	1800	240	3481	210	3046	210	3046	175	2538	175	2538	140	2031		
	B50	158.5	600	2200	1800	240	3481	210	3046	210	3046	175	2538	175	2538	140	2031		
	B52	164.8	600	2200	1800	240	3481	210	3046	210	3046	175	2538	175	2538	140	2031		
	B62	196.7	600	2200	1800	240	3481	210	3046	210	3046	175	2538	175	2538	140	2031		
	B66	213.3	600	2200	1800	240	3481	210	3046	210	3046	175	2538	175	2538	140	2031		
B72	227.1	600	2200	1800	240	3481	210	3046	210	3046	175	2538	175	2538	140	2031			

HF-0, HF2 = Antiwear Petroleum Base
 HF-1 = Non Antiwear Petroleum Base
 HF-5 = Synthetic Fluids
 HF-3 = Water in oil Emulsions
 HF-4 = Water Glycols



AT6CM

FEATURES

- SAE B frame size single vane pump utilizes the same body for all displacements.
- Available flow rates from 16 L/m through 150 L/m
- 2 keyed and 2 splined shaft options, including SAE BB for high torque applications
- 4 different inlet/outlet mounting combinations for ease of installation.
- 1 ½" SAE 4 bolt suction flange / 1" SAE 4 bolt pressure flange

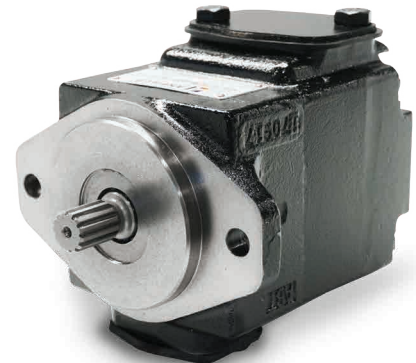

OPERATING CHARACTERISTICS

Model	Volumetric Displacement V _p	Speed	Flow q _v [l/min]			Input power P[kW]		
	cc		rpm	p = 0 bar	p = 140 bar	p = 240 bar	p = 7 bar	p = 140 bar
B03	10.8	1000	10.8	5.8	-	1.0	3.6	-
		1500	16.2	11.2	7.7	1.3	5.3	8.4
B05	17.2	1000	17.2	12.2	8.7	1.1	5.1	8.4
		1500	25.8	20.8	17.3	1.	7.5	12.2
B06	21.3	1000	21.3	16.3	12.8	1.1	6.0	10.0
		1500	31.9	26.9	23.4	1.5	8.9	14.7
B08	26.4	1000	26.4	21.4	17.9	1.2	7.2	12.1
		1500	39.6	34.6	31.1	1.6	10.7	17.7
B10	34.1	1000	34.1	29.1	25.6	1.3	8.9	15.1
		1500	51.1	46.1	42.6	1.7	13.4	22.3
B12	37.1	1000	37.1	32.1	28.6	1.3	9.6	16.3
		1500	55.6	50.6	47.1	1.7	14.4	24.1
B14	46	1000	46.0	41.0	37.5	1.4	11.7	19.9
		1500	69.0	64.0	60.5	1.9	17.6	29.5
B17	58.3	1000	58.3	53.3	49.8	1.6	14.5	24.8
		1500	87.4	82.4	78.9	2.1	21.9	36.9
B20	63.8	1000	63.8	58.8	55.3	1.6	15.8	27.0
		1500	95.7	90.7	87.2	2.2	23.8	40.2
B22	70.3	1000	70.3	65.3	61.8	1.7	17.3	29.6
		1500	105.4	100.4	96.9	2.3	26.1	44.1
B25	79.3	1000	79.3	74.3	70.8	1.8	19.3	33.2
		1500	118.9	113.9	110.4	2.5	29.2	49.5
B28	88.8	1000	88.8	83.8	81.4 ²	1.9	21.9	32.5 ²
		1500	133.2	128.2	125.8 ²	2.8	32.7	48.5 ²
B31	100	1000	100.0	95.0	92.6 ²	2.0	24.4	36.4 ²
		1500	150.0	145.0	142.6 ²	2.8	36.5	54.4 ²

Typical [24 cSt]

1) B25-B28-B31 = 2500 rpm max

2) B28-B31 - 210 bar max int

- Not to use because internal greater than 50% theoretical flow

- Port connection can be furnished with metric threads

AT6CM



DIMENSIONS

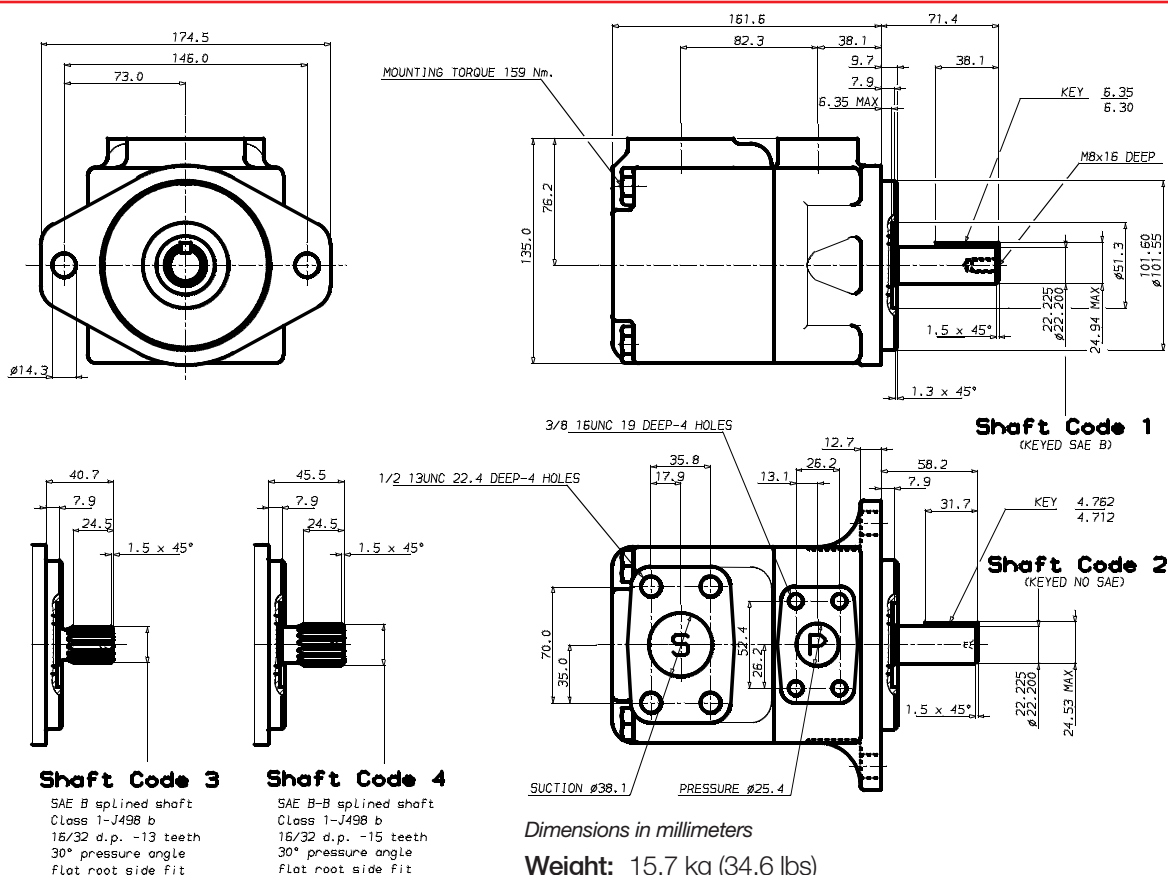

Shaft Torque Limits (ml/rev x bar)	
Shaft	V x p max
1	16500
2	14300
3	20600

ORDERING INFORMATION

AT6CM	B08	2	R	00	A	1
Model	Cam Ring* l/min	Type of Shaft	Direction of Rotation**	Porting Combination	Design Letter	Seal Class
AT6CM	B03 16.2 B05 25.8 B06 31.9 B08 39.6 B10 51.1 B12 55.6 B14 69.0 B17 87.4 B20 95.7 B22 105.4 B25 118.9 B28 133.2 B31 150.0	1 keyed (SAE B) 2 keyed (no SAE) 3 splined (SAE B) 4 splined (SAE BB)	R Clockwise L Counter-clockwise	00 Standard		1 S1 (mineral oil) 5 S5 (mineral oil and fire resistant fluids)

Port	
P	Pressure port
S	Suction port

*Delivery at 0 bar & 1500 rpm
**View on shaft end



AT6DM

FEATURES

- SAE C frame size single vane pump utilizes the same body for all displacements.
- Available flow rates from 71 L/m through 237 L/m
- 2 keyed and 2 splined shaft options.
- 4 different inlet/outlet mounting combinations for ease of installation.
- 2" SAE 4 bolt suction flange / 1 1/4" SAE 4 bolt pressure flange



OPERATING CHARACTERISTICS

Model	Volumetric Displacement V _p	Speed	Flow q _v [l/min]			Input power P[kW]		
	cc		rpm	p = 0 bar	p = 140 bar	p = 240 bar	p = 7 bar	p = 140 bar
B14	47.6	1000	47.6	38.3	32.1	1.5	12.5	20.7
		1500	71.4	62.1	55.9	2.3	18.5	30.6
B17	58.2	1000	87.3	78.0	71.8	2.5	22.2	37.0
		1500	87.3	78.0	71.8	2.5	22.2	37.0
B20	66.0	1000	66.0	56.7	50.5	1.7	16.8	28.0
		1500	99.0	89.7	83.5	2.8	24.9	41.7
B24	79.5	1000	79.5	70.2	64.0	1.9	19.9	33.4
		1500	119.3	110.0	103.8	3.0	29.6	49.8
B28	89.7	1000	89.7	80.4	74.2	2.0	22.3	37.5
		1500	134.5	125.2	119.0	3.2	33.2	55.9
B31	98.3	1000	98.3	89.0	82.8	2.1	24.3	40.9
		1500	147.4	138.1	131.9	3.3	36.2	61.0
B35	111.0	1000	111.0	101.7	95.5	2.3	27.3	46.0
		1500	166.5	157.2	151.0	3.5	40.7	68.7
B38	120.3	1000	120.3	111.0	104.8	2.4	29.4	49.8
		1500	180.4	171.1	164.9	3.7	43.9	74.3
B42 ¹	136.0	1000	136.0	126.7	120.5	2.6	33.1	56.0
		1500	204.0	194.7	188.5	4.0	49.4	83.7
B45 ¹	145.7	1000	145.7	136.4	130.2	2.7	35.3	59.9
		1500	218.5	209.2	203.0	4.1	52.8	89.5
B50 ¹	158.0	1000	158.0	148.7	145.0 ²	2.8	38.2	56.8 ²
		1500	237.0	227.7	224.0 ²	4.4	57.0	85.0 ²

Typical [24 cSt]

1) B25-B28-B31 = 2500 rpm max

2) B28-B31 - 210 bar max int

AT6DM



DIMENSIONS

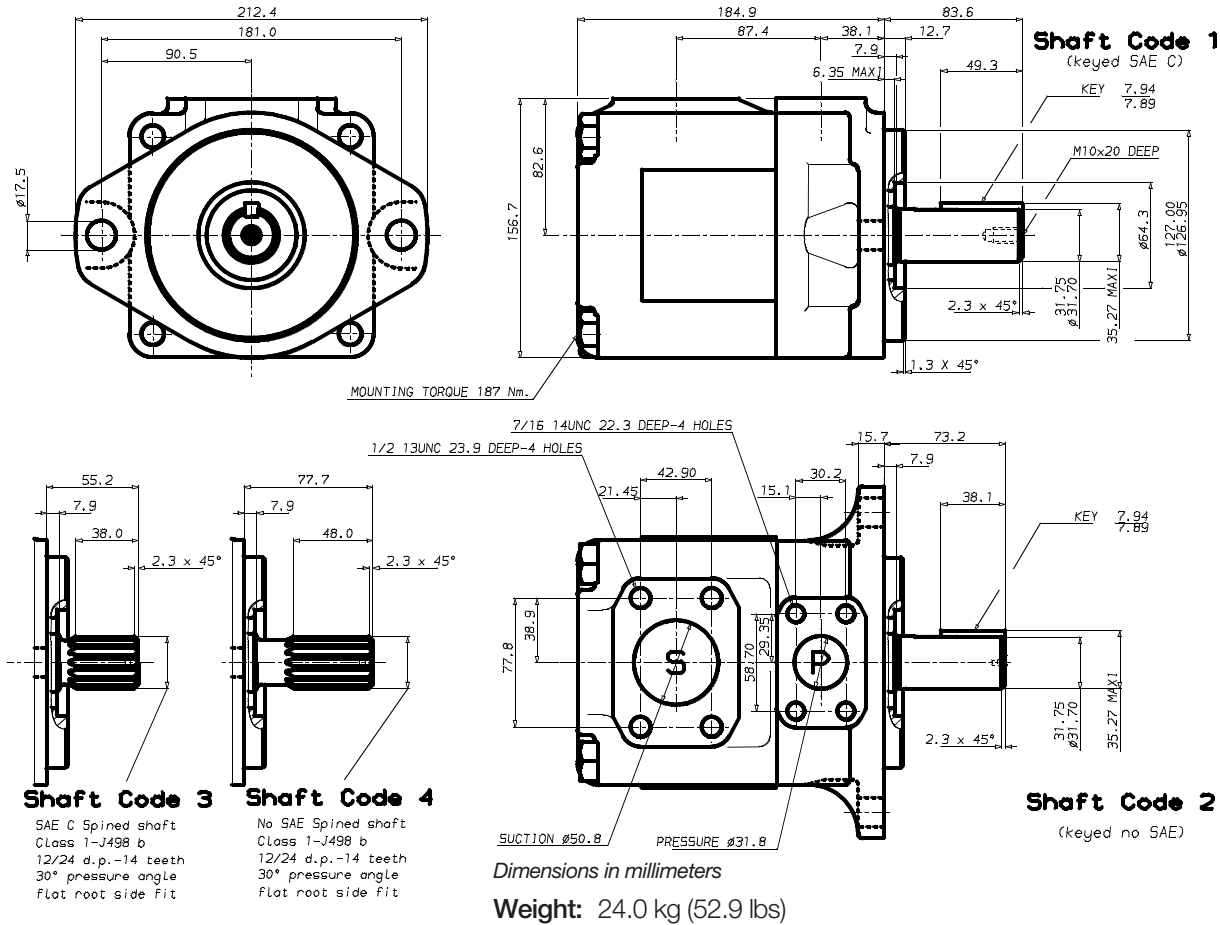

Shaft Torque Limits (ml/rev x bar)	
Shaft	V x p max
2	34590

ORDERING INFORMATION

AT6DM	-	B20	-	4	-	R	-	00	-	A	-	5
Model		Cam Ring* l/min		Type of Shaft		Direction of Rotation**		Porting Combination		Design Letter		Seal Class
AT6DM		B14 71.4 B17 87.3 B20 99.0 B24 119.3 B28 134.5 B31 147.4 B35 166.5 B38 180.4 B42 204.0 B45 218.5 B50 237.0		1 keyed (SAE C) 2 keyed (no SAE) 3 splined (SAE C) 4 splined (no SAE)		R Clockwise L Counter-clockwise		00 Standard 01 Refer to diagram below for orientation 02 03				1 S1 (mineral oil) 5 S5 (mineral oil and fire resistant fluids)
												Port
												P Pressure port S Suction port

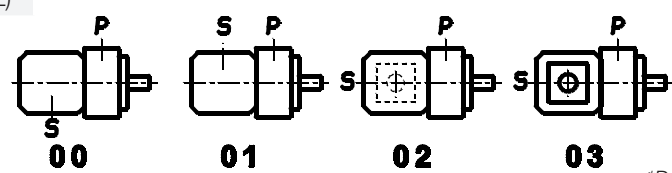

*Delivery at 0 bar & 1500 rpm
**View on shaft end



AT6EM

FEATURES

- SAE CC frame size single vane pump utilizes the same body for all displacements.
- Available flow rates from 198 L/m through 340 L/m
- 2 keyed and 2 splined shaft options.
- 4 different inlet/outlet mounting combinations for ease of installation.
- 2" SAE 4 bolt suction flange/ 1 1/4" SAE 4 bolt pressure flange



OPERATING CHARACTERISTICS

Model	Volumetric Displacement V _p	Speed	Flow q _v [l/min]			Input power P[kW]		
	cc		rpm	p = 0 bar	p = 140 bar	p = 240 bar	p = 7 bar	p = 140 bar
B42	132.3	1000	132.3	122.3	115.2	3.2	32.9	55.2
		1500	198.5	188.5	181.3	5.2	49.4	82.6
B45	142.4	1000	142.4	132.4	125.3	3.4	35.3	59.2
		1500	213.6	203.6	196.5	5.4	52.9	88.7
B50	158.5	1000	158.5	148.5	141.4	3.5	39.0	65.6
		1500	237.7	227.7	220.6	5.7	58.5	98.3
B52	164.8	1000	164.8	154.8	147.7	3.6	40.5	68.2
		1500	247.2	237.2	230.1	5.8	60.8	102.1
B62	196.7	1000	196.7	186.7	179.6	4.0	47.9	80.9
		1500	295.0	285.0	277.9	6.4	71.9	121.3
B66	213.3	1000	213.3	203.3	196.2	4.2	51.8	87.6
		1500	319.9	309.0	302.8	6.7	77.7	131.2
B72	227.1	1000	227.1	217.1	210.0	4.3	55.0	93.1
		1500	340.6	330.6	323.5	6.9	82.6	139.5

Port connection can be furnished with metric threads

AT6EM



DIMENSIONS

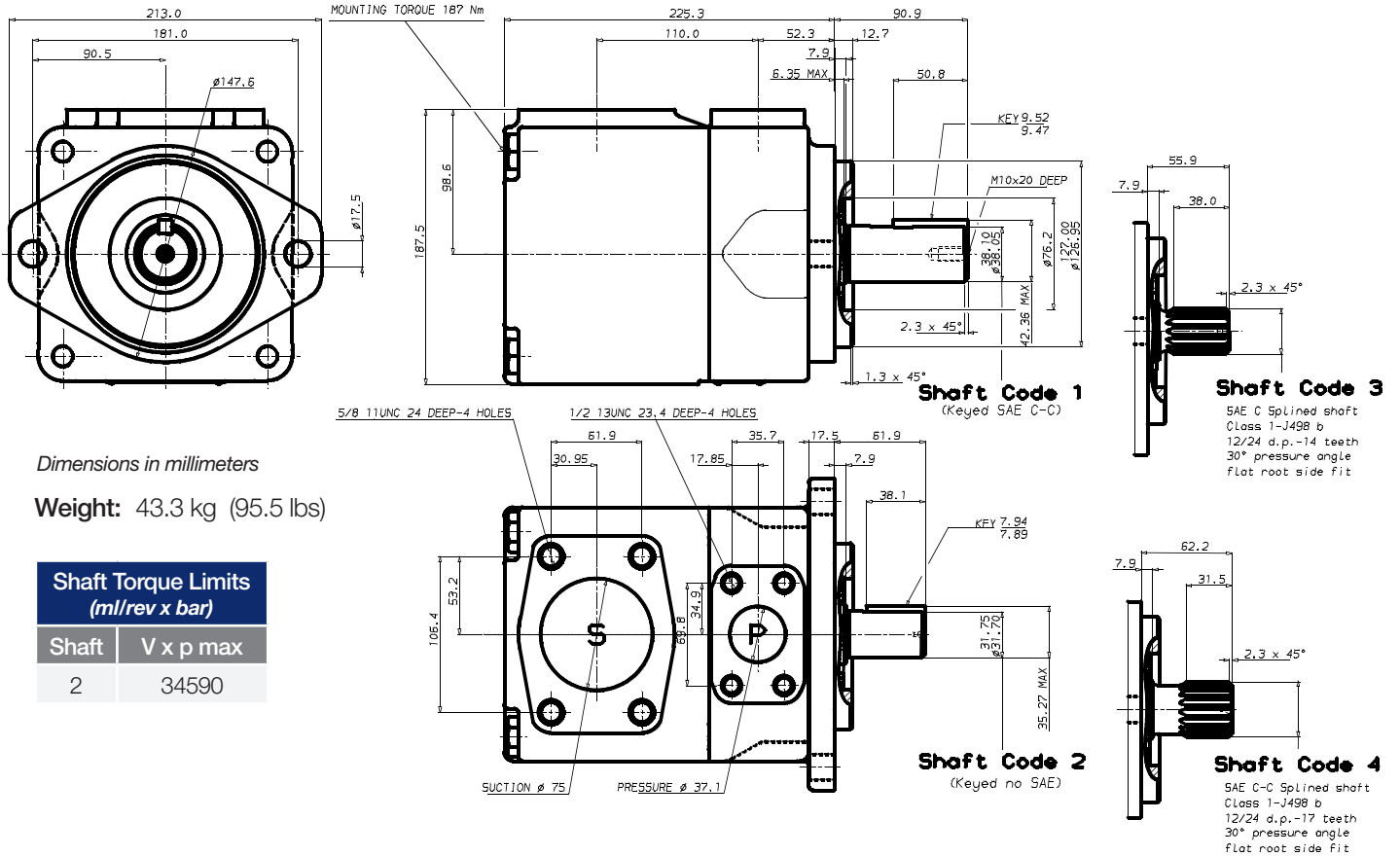

ORDERING INFORMATION

AT6EM	-	B50	-	3	-	R	-	00	-	A	-	1
Model		Cam Ring* l/min		Type of Shaft		Direction of Rotation**		Porting Combination		Design Letter		Seal Class
AT6EM		B42 198.5 B45 213.6 B50 237.7 B52 247.2 B62 295.0 B66 319.9 B72 340.6		1 keyed (SAE CC) 2 keyed (no SAE) 3 splined (SAE C) 4 splined (SAE CC)		R Clockwise L Counter-clockwise		00 Standard 01 Refer to diagram below for orientation 02 03		A		1 S1 (mineral oil) 5 S5 (mineral oil and fire resistant fluids)

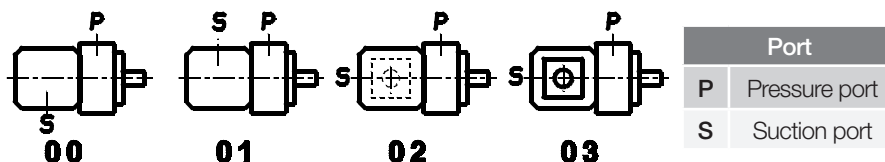

*Delivery at 0 bar & 1500 rpm
**View on shaft end



AT6CCM

FEATURES

- SAE B frame size double vane pump
- Available flow rates from 16 L/m through 150 L/m
- 2 keyed and 1 splined shaft options, including SAE BB for high torque applications
- Multiple inlet/outlet mounting combinations for ease of installation.
- Common SAE 4 bolt suction flange and dual outlet pressure flange

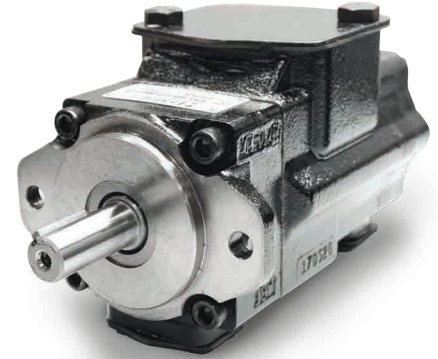

OPERATING CHARACTERISTICS

Pressure Port	Model	Volumetric Displacement Vp	Flow q_v [l/min] & n = 1500 RPM			Input power P[kW]		
		cc	p = 0 bar	p = 140 bar	p = 240 bar	p = 7 bar	p = 140 bar	p = 240 bar
P1 & P2	B03	10.8	16.2	11.2	7.7	1.3	5.3	8.4
	B05	17.2	25.8	20.8	17.3	1.4	7.5	12.2
	B06	21.3	31.9	26.9	23.4	1.5	8.9	14.7
	B08	26.4	39.6	34.6	31.1	1.6	10.7	17.7
	B10	34.1	51.1	46.1	42.6	1.7	13.4	22.3
	B12	37.1	55.6	50.6	47.1	1.7	14.4	24.1
	B14	46.0	69.0	64.0	60.5	1.9	17.6	29.5
	B17	58.3	87.4	82.4	78.9	2.1	21.9	36.9
	B20	63.8	95.7	90.7	87.2	2.2	23.8	40.2
	B22	70.3	105.4	100.4	96.9	2.3	26.1	44.1
	B25 ¹	79.3	118.9	113.9	110.4	2.5	29.2	49.5
	B28 ¹	88.8	133.2	128.2	125.8 ²	2.8	32.7	48.5 ²
B31 ¹	100.0	150.0	145.0	142.6 ²	2.8	36.5	54.4 ²	

1) B25 - B28 - B31 = 2500 RPM max

2) B28 - B31 = 210 bar max int

Port connection can be furnished with metric threads

AT6CCM



DIMENSIONS

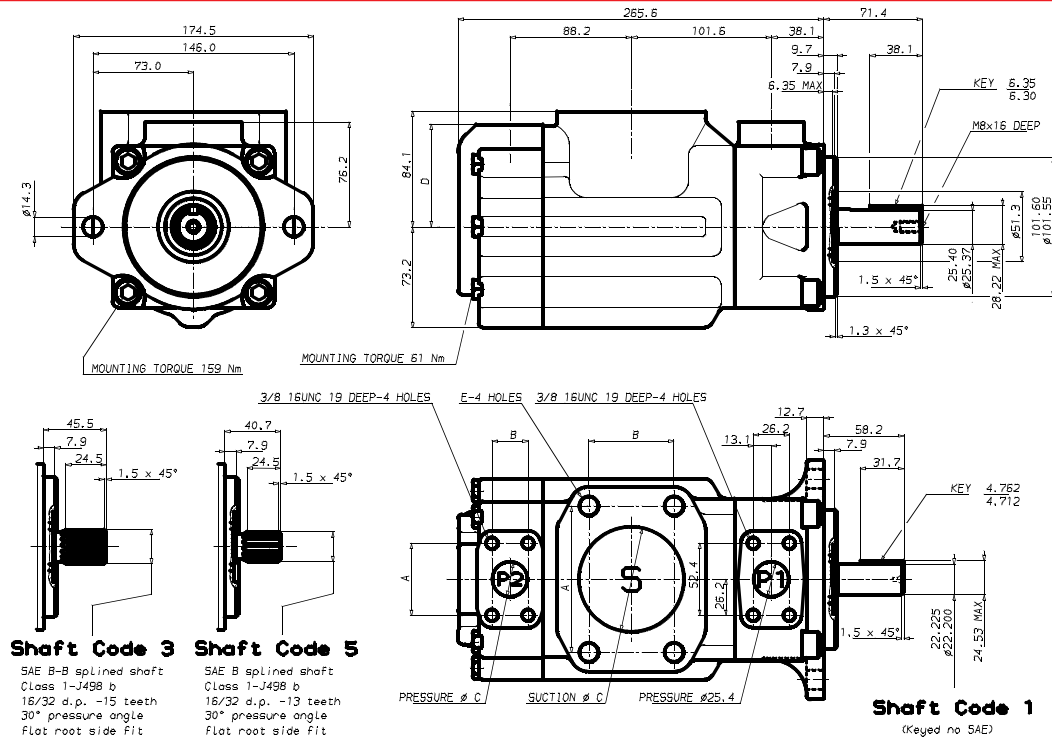

Dimensions in millimeters

Weight: 26.0 kg (57.3 lbs)

Porting Combinations						
Port	Size	A	B	C	D	E
S	3"	106.4	61.9	76.2	-	5/8"-11 x 28.4 deep
S	2-1/2"	88.9	50.8	63.5	-	1/2"-13 x 23.9 deep
P1	1"	52.4	26.2	25.4	76.2	3/8"-16 x 19.0 deep
P2	3/4"	47.7	22.2	19.0	76.2	3/8"-16 x 19.0 deep
P2	1"	52.4	26.2	25.4	74.7	3/8"-16 x 19.0 deep

Shaft Torque Limits (ml/rev x bar)	
Shaft	V x p max P1 + P2
1	14300
3	32670
5	20600

ORDERING INFORMATION

AT6CCM	-	B31	-	B20	-	3	-	R	-	00	-	A	-	1	-	00
Model		P1		P2		Type of Shaft		Direction of Rotation**		Porting Combination***		Design Letter		Seal Class		Mounting with Connection Variables
AT6CCM		B03	16.2	B05	25.8	1	keyed (No SAE)	R	Clockwise	00	Standard	A	1	S1 (mineral oil)	00	P1=1", S=3", P2=1"
		B06	31.9	B08	39.6	3	splined (SAE BB)	L	Counter-clockwise				5	S5 (mineral oil and fire resistant fluids)	01	P1=1", S=3", P2=3/4"
		B10	51.1	B12	55.6	5	splined (SAE B)								10	P1=1", S=2-1/2" ² , P2=1"
		B14	69.0	B17	87.4										11	P1=1", S=2-1/2" ² , P2=3/4" ¹
		B20	95.7	B22	105.4											
		B25	118.9	B28	133.2											
		B31	150.0													

*Delivery at 0 bar & 1500 rpm

**View on shaft end

***See page 22 for more porting combinations



AT6DCM

FEATURES

- SAE C frame size double vane pump
- Available flow rates from 71 L/m through 237 L/m
- 2 keyed and 2 splined shaft options.
- Multiple inlet/outlet mounting combinations for ease of installation.
- Common SAE 4 bolt suction flange/ dual SAE 4 bolt outlet pressure flange



OPERATING CHARACTERISTICS

Pressure Port	Model	Volumetric Displacement V _p	Flow q _v [l/min] & n = 1500 RPM			Input power P[kW]		
		cc	p = 0 bar	p = 140 bar	p = 240 bar	p = 7 bar	p = 140 bar	p = 240 bar
P1	B14	47.6	71.4	62.1	55.9	2.3	18.5	30.6
	B17	58.2	87.3	78.0	71.8	2.5	22.2	37.0
	B20	66.0	99.0	89.7	83.5	2.8	24.9	41.7
	B24	79.5	119.3	110.0	103.8	3.0	29.6	49.8
	B28	89.7	134.5	125.2	119.0	3.2	33.2	55.9
	B31	98.3	147.4	138.1	131.9	3.3	36.2	61.0
	B35	111.0	166.5	157.2	151.0	3.5	40.7	68.7
	B38	120.3	180.4	171.1	164.9	3.7	43.9	74.3
	B42	136.0	204.0	194.7	188.5	4.0	49.4	83.7
	B45	145.7	218.5	209.2	203.0	4.1	52.8	89.5
	B50 ²	158.0	237.0	227.7	224.0 ¹	4.4	57.0	85.0 ¹
P2	B03	10.8	16.2	11.2	7.7	1.3	5.3	8.4
	B05	17.2	25.8	20.8	17.3	1.4	7.5	12.2
	B06	21.3	31.9	26.9	23.4	1.5	8.9	14.7
	B08	26.4	39.6	34.6	31.1	1.6	10.7	17.7
	B10	34.1	51.1	46.1	42.6	1.7	13.4	22.3
	B12	37.1	55.6	50.6	47.1	1.7	14.4	24.1
	B14	46.0	69.0	64.0	60.5	1.9	17.6	29.5
	B17	58.3	87.4	82.4	78.9	2.1	21.9	36.9
	B20	63.8	95.7	90.7	87.2	2.2	23.8	40.2
	B22	70.3	105.4	100.4	96.9	2.3	26.1	44.1
	B25	79.3	118.9	113.9	110.4	2.5	29.2	49.5
B28	88.8	133.2	128.2	125.8 ¹	2.8	32.7	48.5 ¹	
B31	100.0	150.0	145.0	142.6 ¹	2.8	36.5	54.4 ¹	

1) B28 - B31 - B50 = 210 bar max. int.
 2) B42 - B45 - B50 = 2200 R.P.M. max
 Port connection can be furnished with metric threads.

AT6DCM



DIMENSIONS

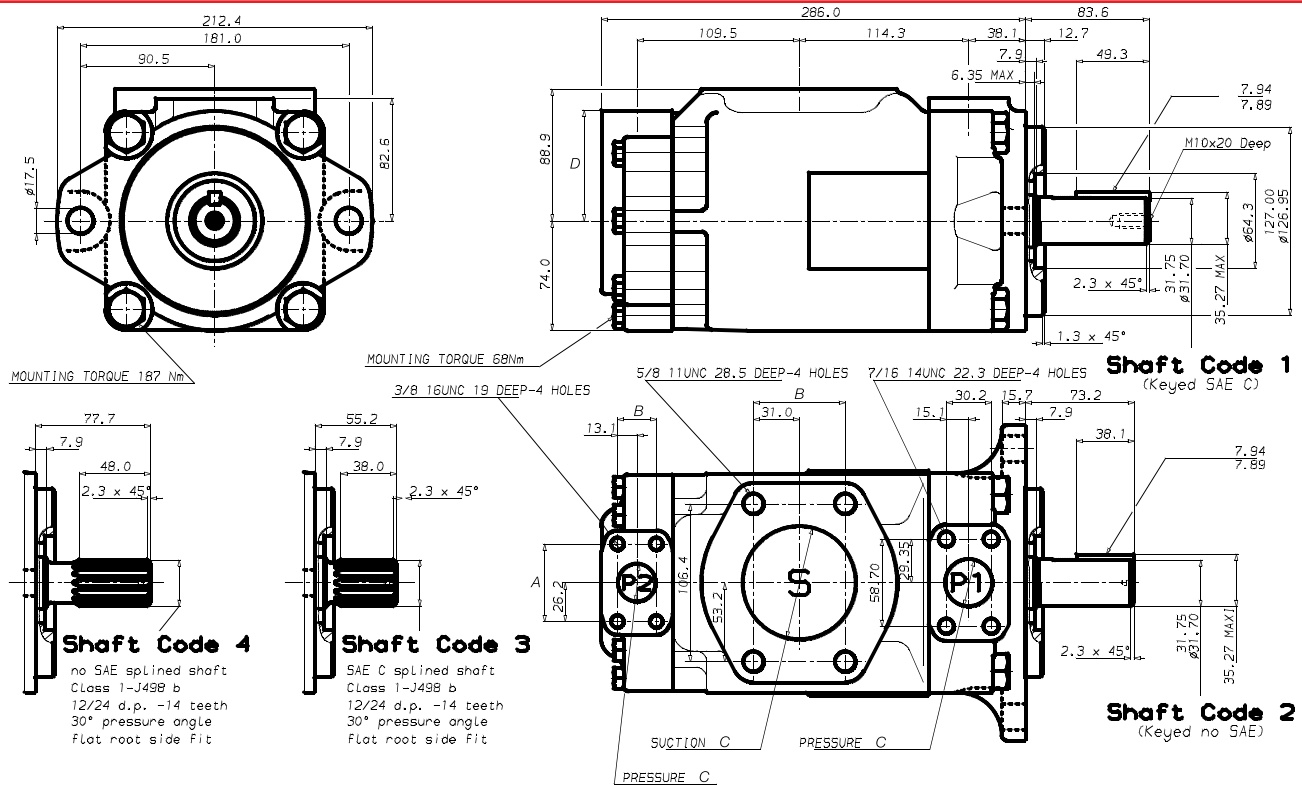

Dimensions in millimeters

Weight: 36.6 kg (80.7 lbs)

Porting Combinations						
Port	Size	A	B	C	D	E
P1	1-1/4"	58.7	30.2	31.8	82.6	7/16"-14 X 22.3 deep
P2	1"	52.4	26.2	25.4	74.7	3/8"-16 X 19.0 deep
P2	3/4"	47.6	22.2	19.0	74.7	3/8"-16 X 19.0 deep
S	3"	106.4	61.9	76.2	88.9	5/8"-11 X 28.4 deep

Shaft Torque Limits (ml/rev x bar)	
Shaft	V x p max P1 + P2
1	43240
2	34590
5	55600

ORDERING INFORMATION

Model	Cam Ring* l/min	Cam Ring* l/min	Type of Shaft	Direction of Rotation**	Porting Combination***	Design Letter	Seal Class	Mounting with Connection Variables
AT6DCM	B14 71.4 B17 87.3 B20 99.0 B24 119.3 B28 134.4 B31 147.4 B35 166.5 B38 180.4 B42 204.0 B45 218.5 B50 237.0	B03 16.2 B05 25.8 B06 31.9 B08 39.6 B10 51.1 B12 55.6 B14 69.0 B17 87.4 B20 95.7 B22 105.4 B25 118.9 B28 133.2 B31 150.0	1 keyed (SAE C) 2 keyed (No SAE) 3 splined (SAE C) 4 splined (No SAE)	R Clockwise L Counter-clockwise	00 Standard	A	1 S1 (mineral oil) 5 S5 (mineral oil and fire resistant fluids)	00 P1=1-1/4", P2 = 1" , S=3" 01 P1=1-1/4", P2 = 3/4" , S=3"

*Delivery at 0 bar & 1500 rpm

**View on shaft end

***See page 22 for more porting combinations



AT6EDM

FEATURES

- SAE CC frame size double vane pump utilizes the same body for all displacements.
- Available flow rates from 198 L/m through 340 L/m
- 2 keyed and 2 splined shaft options.
- Multiple inlet/outlet mounting combinations for ease of installation.
- Common SAE 4 bolt suction flange/ dual SAE 4 bolt outlet pressure flange



OPERATING CHARACTERISTICS

Pressure Port	Model	Volumetric Displacement V _p	Flow q _v [l/min] & n = 1500 RPM			Input power P[kW]		
		cc	p = 0 bar	p = 140 bar	p = 240 bar	p = 7 bar	p = 140 bar	p = 240 bar
P1	B42	132.2	198.5	188.5	181.3	5.2	49.4	82.6
	B45	142.4	213.6	203.6	196.5	5.4	52.9	88.7
	B50	158.5	237.7	227.7	220.6	5.7	58.5	98.3
	B52	164.8	247.2	237.2	230.1	5.8	60.8	102.1
	B62	196.7	295.0	285.0	277.9	6.4	71.9	121.3
	B66	213.3	319.9	309.9	302.8	6.7	77.7	131.2
	B72	227.1	340.6	330.6	323.5	6.9	82.6	139.5
P2	B14	47.6	71.4	62.1	55.9	2.3	18.5	30.6
	B17	87.3	87.3	78.0	71.8	2.5	22.2	37.0
	B20	66.0	99.0	89.7	83.5	2.8	24.9	41.7
	B24	79.5	119.3	110.0	103.8	3.0	29.6	49.8
	B28	89.7	134.5	125.2	119.0	3.2	33.2	55.9
	B31	98.3	147.4	138.1	131.9	3.3	36.2	61.0
	B35	111.0	166.5	157.2	151.0	3.5	40.7	68.7
	B38	120.3	180.4	171.1	164.9	3.7	43.9	74.3
	B42	136.0	204.0	194.7	188.5	4.0	49.4	83.7
	B45	145.7	218.5	209.2	203.0	4.1	52.8	89.5
	B50	158.0	237.0	227.7	224.0 ¹	4.4	57.0	85.0 ¹

1) B50 = 210 bar max. int. Port connection can be furnished with metric threads.



DIMENSIONS

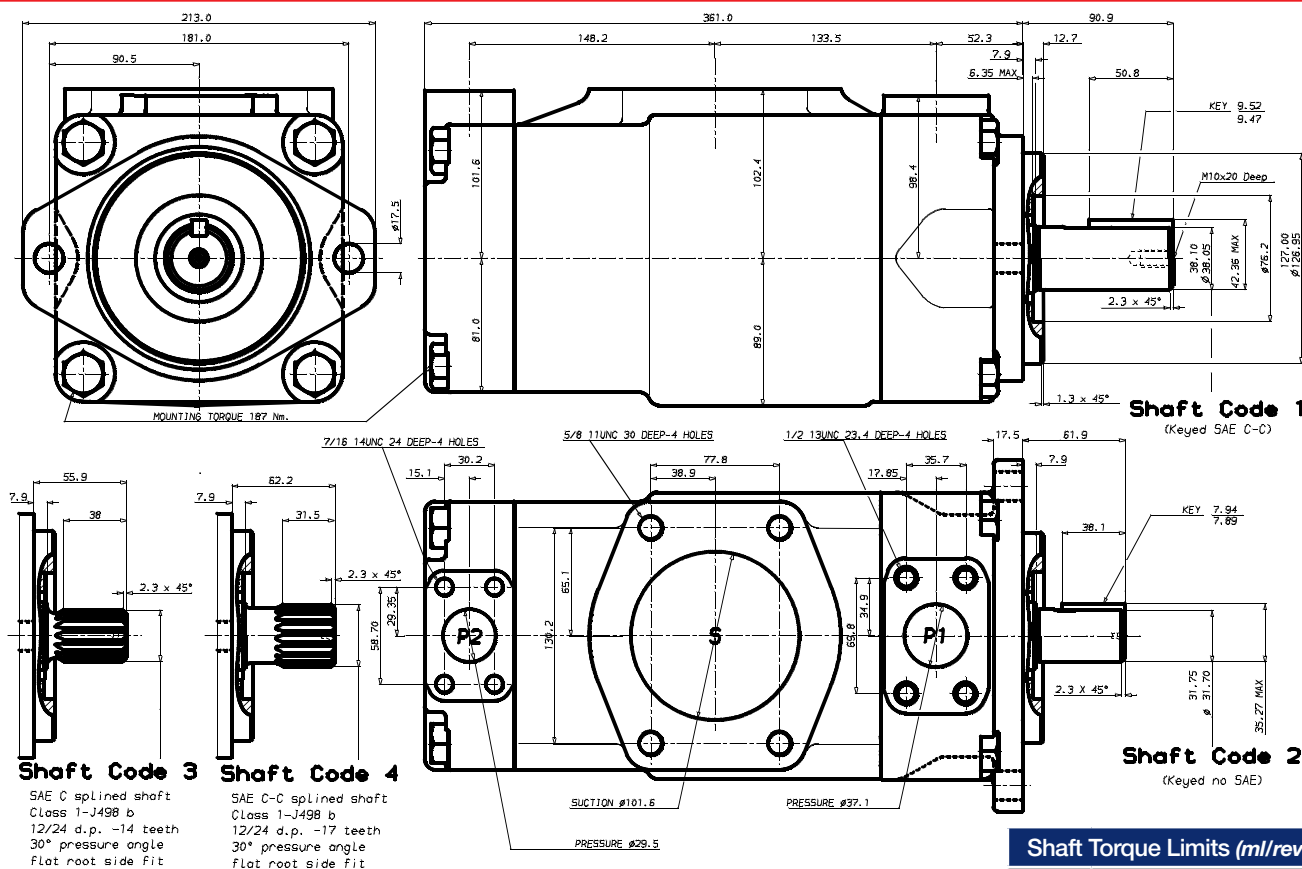

Dimensions in millimeters

Weight: 66 kg (145.5 lbs)

Shaft Torque Limits (ml/rev x bar)

Shaft	V x p max P1 + P2
1	72306
2	34590
3	61200

ORDERING INFORMATION

AT6EDM	B42	B14	3	R	00	A	5
	P1	P2					
Model	Cam Ring* l/min	Cam Ring* l/min	Type of Shaft	Direction of Rotation**	Porting Combination***	Design Letter	Seal Class
AT6EDM	B42 198.5	B14 69.0	1 keyed (SAE CC)	R Clockwise	00 Standard		1 S1 (mineral oil)
	B45 213.6	B17 87.4	2 keyed (No SAE)	L Counter- clockwise			5 S5 (mineral oil and fire resistant fluids)
	B50 237.7	B20 95.7	3 splined (SAE C)				
	B52 247.2	B22 105.4	4 splined (SAE CC)				
	B62 295.0	B25 118.9					
	B66 319.9	B28 133.2					
	B72 340.6	B31 150.0					
		B35 166.5					
		B38 180.4					
		B42 204.0					
		B45 218.5					
		B50 237.0					

*Delivery at 0 bar & 1500 rpm

**View on shaft end

***See page 22 for more porting combinations



AT6DCCM

FEATURES

- SAE C frame size triple vane pump
- Front section flow rates from 71 L/m through 237 L/m
- Second and third section flow rates from 16 L/m through 150 L/m
- 2 keyed and 2 splined shaft options.
- Multiple inlet/outlet mounting combinations for ease of installation.
- Common SAE 4 bolt suction flange/ triple SAE 4 bolt outlet pressure flanges

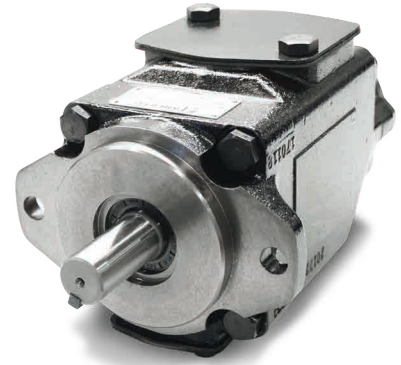

OPERATING CHARACTERISTICS

Pressure Port	Model	Volumetric Displacement V _p	Flow q _v [l/min] & n = 1500 RPM			Input power P[kW]		
		cc	p = 0 bar	p = 140 bar	p = 240 bar	p = 7 bar	p = 140 bar	p = 240 bar
P1	B14	47.6	71.4	62.1	55.9	2.3	18.5	30.6
	B17	58.2	87.3	78.0	71.8	2.5	22.2	37.0
	B20	66.0	99.0	89.7	83.5	2.8	24.9	41.7
	B24	79.5	119.3	110.0	103.8	3.0	29.6	49.8
	B28	89.7	134.5	125.2	119.0	3.2	33.2	55.9
	B31	98.3	147.4	138.1	131.9	3.3	36.2	61.0
	B35	111.0	166.5	157.2	151.0	3.5	40.7	68.7
	B38	120.3	180.4	171.1	164.9	3.7	43.9	74.3
	B42 ²	136.0	204.0	194.7	188.5	4.0	49.4	83.7
	B45 ²	145.7	218.5	209.2	203.0	4.1	52.8	89.5
B50 ²	158.0	237.0	227.7	224.0 ¹	4.4	57.0	85.0 ¹	
P2 & P3	B03	10.8	16.2	11.2	7.7	1.3	5.3	8.4
	B05	17.2	25.8	20.8	17.3	1.4	7.5	12.2
	B06	21.3	31.9	26.9	23.4	1.5	8.9	14.7
	B08	26.4	39.6	34.6	31.1	1.6	10.7	17.7
	B10	34.1	51.1	46.1	42.6	1.7	13.4	22.3
	B12	37.1	55.6	50.6	47.1	1.7	14.4	24.1
	B14	46.0	69.0	64.0	60.5	1.9	17.6	29.5
	B17	58.3	87.4	82.4	78.9	2.1	21.9	36.9
	B20	63.8	95.7	90.7	87.2	2.2	23.8	40.2
	B22	70.3	105.4	100.4	96.9	2.3	26.1	44.1
B25	79.3	118.9	113.9	110.4	2.5	29.2	49.5	
B28	88.8	133.2	128.2	125.8 ¹	2.8	32.7	48.5 ¹	
B31	100.0	150.0	145.0	142.6 ¹	2.8	36.5	54.4 ¹	

1) B28 - B31 - B50 = 210 bar max. int.

2) B42 - B45 - B50 = 2200 R.P.M. max

AT6DCCM



DIMENSIONS

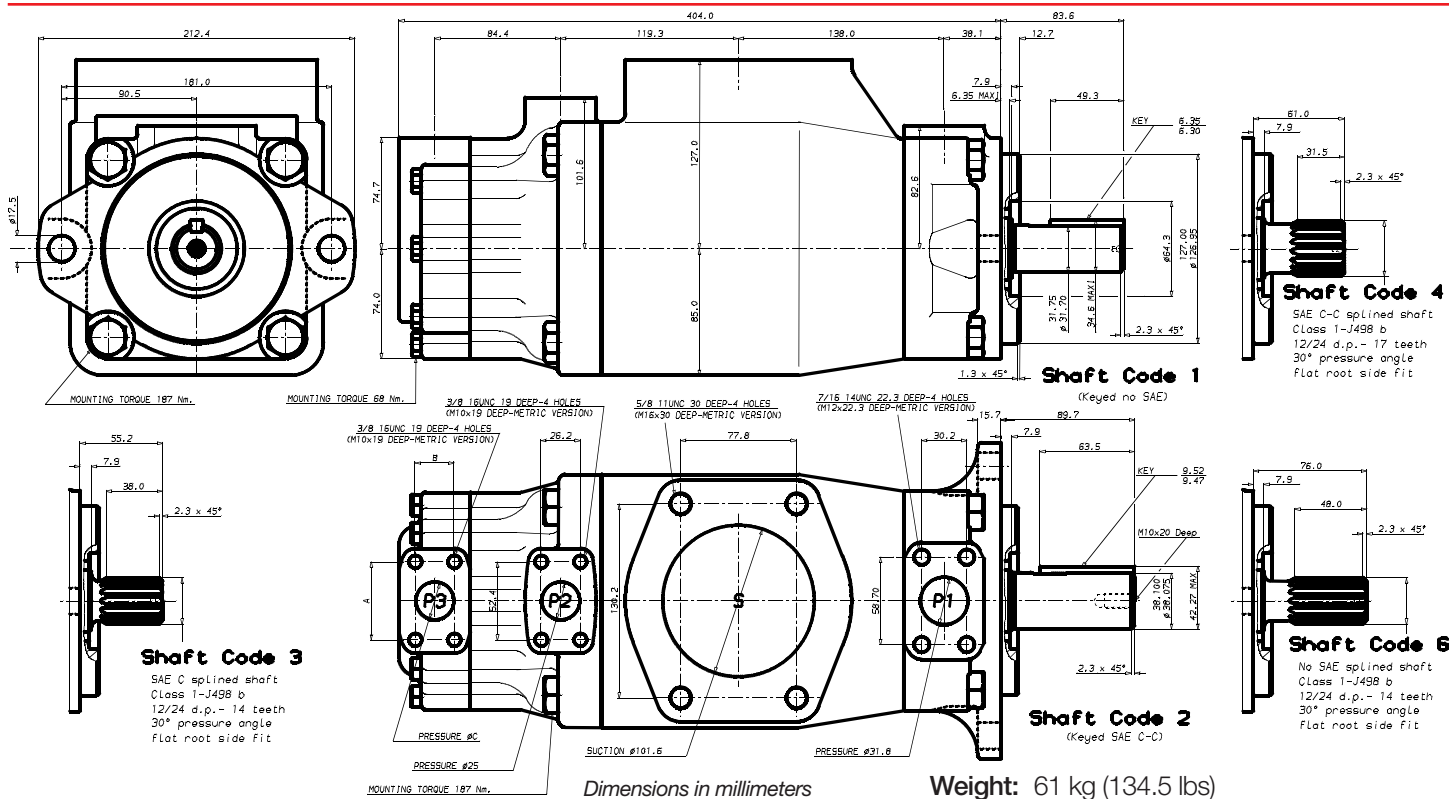

Alternate Port				
Port	Size	A	B	C
P3	1"	52.4	26.2	25.4
P3	3/4"	47.6	22.2	19.0

Shaft Torque Limits (ml/rev x bar)					
Shaft	Vi x p max	P1 + P2 + P3	Shaft	Vi x p max	P1 + P2 + P3
1		72306	3		61200
2		34590	4		66500

ORDERING INFORMATION

Model	Cam Ring* l/min	Cam Ring* l/min	Type of Shaft	Direction of Rotation**	Porting Combination***	Design Letter	Seal Class	Mounting with Connection Variables
AT6DCCM	B14 71.4 B17 87.3 B20 99.0 B24 119.3 B28 134.5 B31 147.4 B35 166.5 B38 180.4 B42 204.0 B45 218.5 B50 237.0	B03 16.2 B05 25.8 B06 31.9 B08 39.6 B10 51.1 B12 55.6 B14 69.0 B17 87.4 B20 95.7 B22 105.4 B25 118.9 B28 133.2 B31 150.0	1 keyed (No SAE) 2 keyed (SAE CC) 3 splined (SAE C) 4 splined (SAE CC) 6 splined (No SAE)	R Clockwise L Counter-clockwise	00 Standard	A	1 S1 (mineral oil) 5 S5 (mineral oil and fire resistant fluids)	00 P3=1" 01 P3=3/4"

*Delivery at 0 bar & 1500 rpm
**View on shaft end
***See page 22 for more porting combinations



AT6EDCS

FEATURES

- SAE D frame size triple vane pump
- Front section flow rates from 198 L/m through 340 L/m
- Second section flow rates from 71 L/m through 237 L/m
- Third section flow rates from 16 L/m through 150 L/m
- Multiple inlet/outlet mounting combinations for ease of installation.
- Common SAE 4 bolt suction flange/ triple SAE 4 bolt outlet pressure flange



OPERATING CHARACTERISTICS

Pressure Port	Model	Volumetric Displacement Vp cc	Flow qv _e [l/min] & n = 1500 RPM			Input power P[kW]		
			p = 0 bar	p = 140 bar	p = 240 bar	p = 7 bar	p = 140 bar	p = 240 bar
P1	B42	132.3	198.5	188.5	181.3	5.2	49.4	82.6
	B45	142.4	213.6	203.6	196.5	5.4	52.9	88.7
	B50	158.5	237.7	227.7	220.6	5.7	58.5	98.3
	B52	164.8	247.2	237.2	230.1	5.8	60.8	102.1
	B62	196.7	295.0	285.0	277.9	6.4	71.9	121.3
	B66	213.3	319.9	309.9	302.8	6.7	77.7	131.2
	B72	227.1	340.6	330.6	323.5	6.9	82.6	139.5
P2	B14	47.6	71.4	62.1	55.9	2.3	18.5	30.6
	B17	58.2	87.3	78.0	71.8	2.5	22.2	37.0
	B20	66.0	99.0	89.7	83.5	2.8	24.9	41.7
	B24	79.5	119.3	110.0	103.8	3.0	29.6	49.8
	B28	89.7	134.5	125.2	119.0	3.2	33.2	55.9
	B31	98.3	147.4	138.1	131.9	3.3	36.2	61.0
	B35	111.0	166.5	157.2	151.0	3.5	40.7	68.7
	B38	120.3	180.4	171.1	164.9	3.7	43.9	74.3
	B42	136.0	204.0	194.7	188.5	4.0	49.4	83.7
	B45	145.7	218.5	209.2	203.0	4.1	52.8	89.5
	B50	158.0	237.0	227.7	224.0 ¹	4.4	57.0	85.0 ¹
P3	B03	10.8	16.2	10.7	7.7	1.3	5.3	8.4
	B05	17.2	25.8	20.3	15.8	1.4	7.5	12.2
	B06	21.3	31.9	26.5	22.0	1.5	8.9	14.7
	B08	26.4	39.6	34.1	29.6	1.6	10.7	17.7
	B10	34.1	51.1	45.7	41.2	1.7	13.4	22.3
	B12	37.1	55.6	50.2	45.7	1.7	14.4	24.1
	B14	46.0	69.0	63.5	59.0	1.9	17.6	29.5
	B17	58.3	87.4	80.0	77.5	2.1	21.9	36.9
	B20	63.8	95.7	90.2	85.7	2.2	23.8	40.2
	B22	70.3	105.4	100.0	95.5	2.3	26.1	44.1
	B25	79.3	118.9	113.5	109.0	2.5	29.2	49.5
	B28	88.8	133.2	127.7	124.5 ¹	2.8	32.7	48.5 ¹
	B31	100.0	150.0	144.5	141.3 ¹	2.8	36.5	54.4 ¹

1) B28 - B31 - B50 = 210 bar max. int.

AT6EDCS



DIMENSIONS

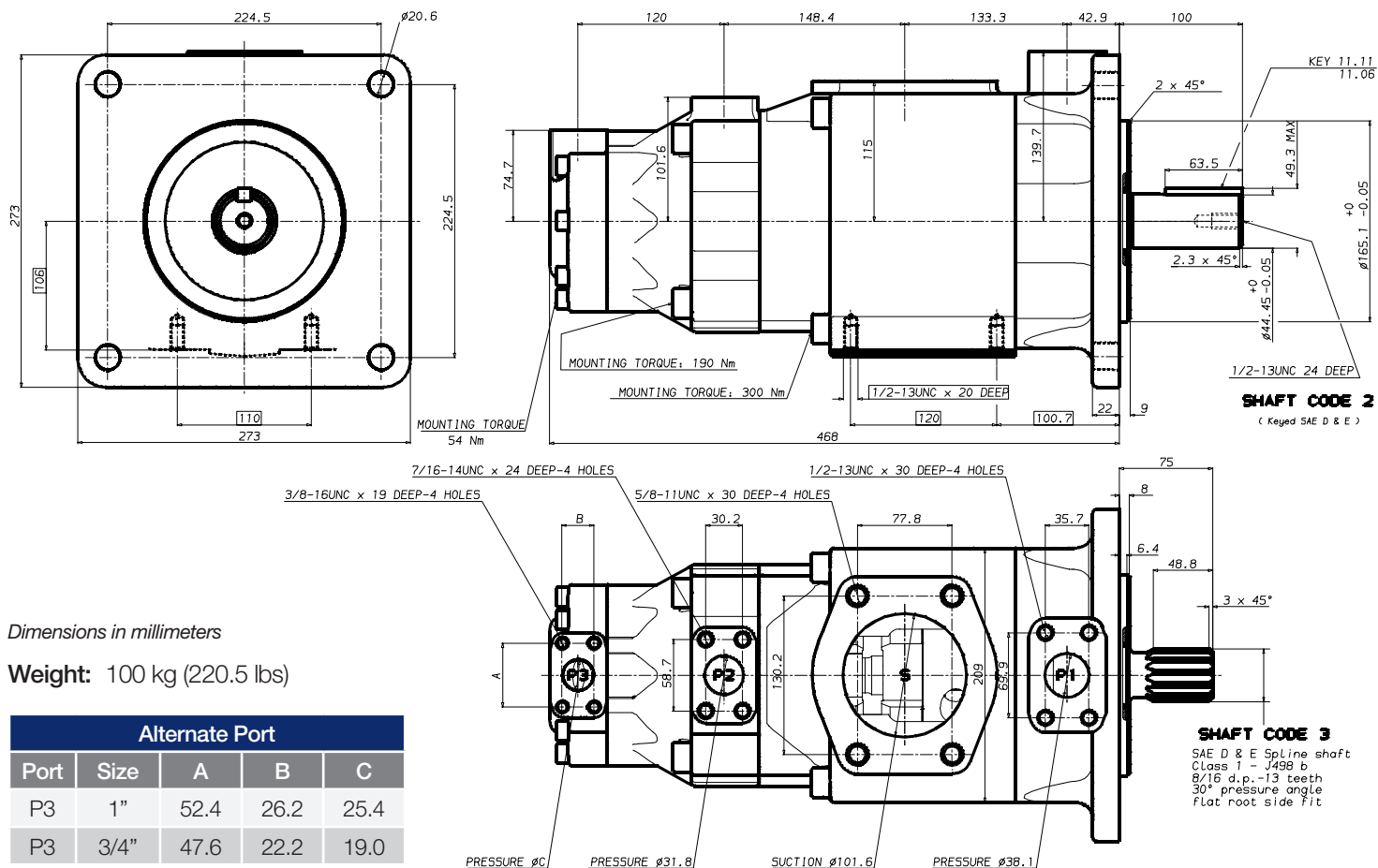

ORDERING INFORMATION

Model	Cam Ring* l/min	Cam Ring* l/min	Cam Ring* l/min	Type of Shaft	Direction of Rotation**	Porting Combination	Design Letter	Seal Class	Mounting Support	Mounting with Connection Variables
AT6EDCS	B42 198.5	B14 71.4	B03 16.2	1 keyed (G45N-ISO 3019-2)	R Clockwise	00 Standard	A	1 S1 (mineral oil)	F Standard	00 P3 = 1"
	B45 213.6	B17 87.3	B05 25.8	2 keyed (SAE D & E)	L Counter-clockwise			5 S5 (mineral oil and fire resistant fluids)		01 P3 = 3/4"
	B50 237.7	B20 99.0	B06 31.9	3 splined (SAE D & E)						
	B52 247.2	B24 119.3	B08 39.6							
	B62 295.0	B28 134.5	B10 51.1							
	B66 319.9	B31 147.4	B12 55.6							
	B72 340.6	B35 166.5	B14 69.0							
		B38 180.4	B17 87.4							
		B42 204.0	B20 95.7							
		B45 218.5	B22 105.4							
		B50 237.0	B25 118.9							
			B28 133.2							
			B31 150.0							

*Delivery at 0 bar & 1500 rpm
**View on shaft end
***See page 22 for more porting combinations



Porting Diagrams

AT6CCM - AT6DCM

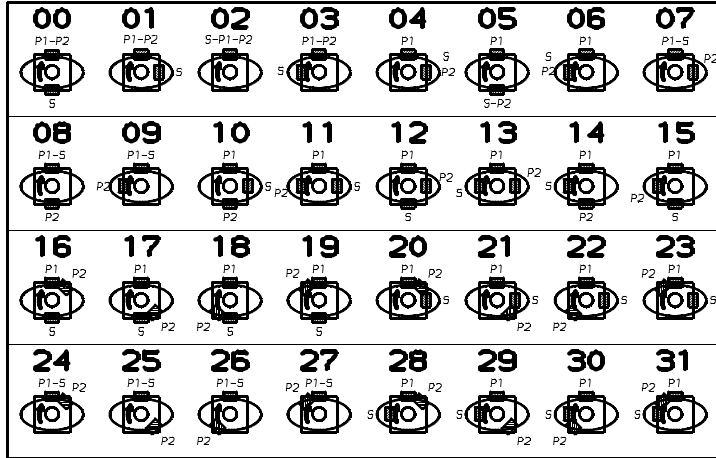

AT6EDM

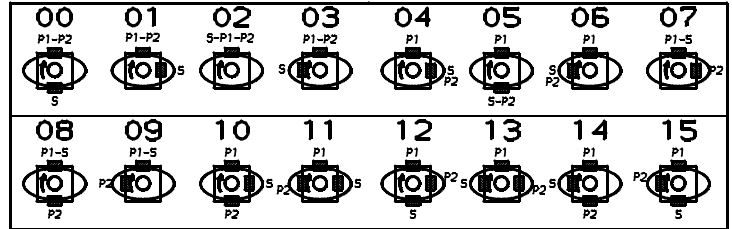

AT6DCCM - AT6EDCS

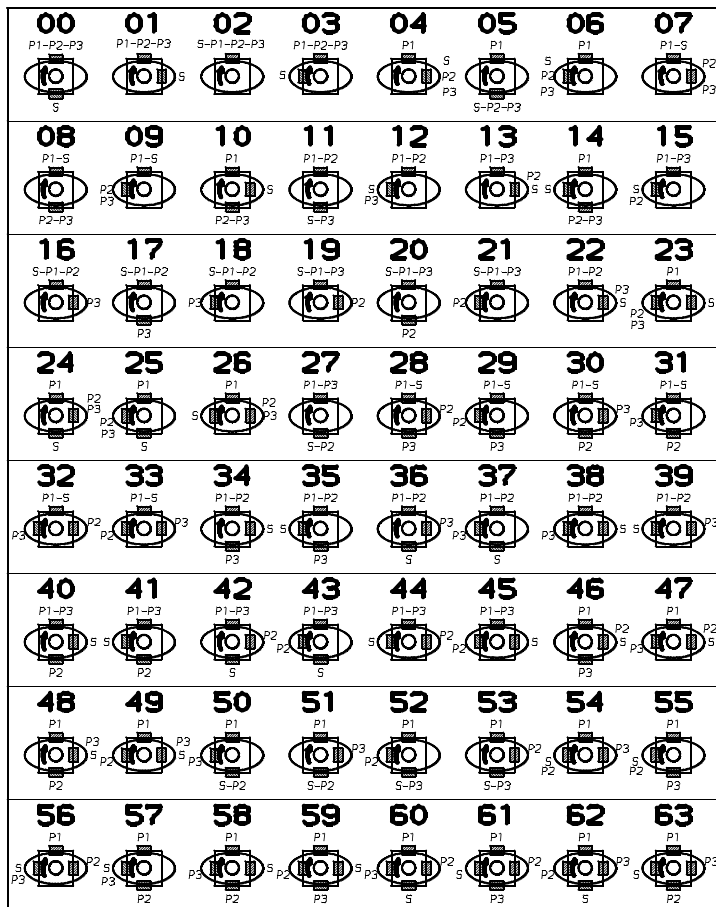

Cartridge Kits



ORDERING INFORMATION

F		AT6EM - B62							R	S5			
Position		Series and Flow							Rotation*	Seal Material			
F	Front or single pump	AT6CM	AT6DM	AT6EM	AT6CCM	AT6DCM	AT6EDM	AT6DCCM	AT6EDCS	R	Clockwise	S1	NBR Nitrile
M	Middle	B03	B14	B42	B03	B03	B14	B03	B03	L	Counter-clockwise	S5	Viton™
R	Rear	B05	B17	B45	B05	B05	B17	B05	B05	<i>*View on shaft end</i>			
		B06	B20	B50	B06	B06	B20	B06	B06				
		B08	B24	B52	B08	B08	B24	B08	B08				
		B10	B28	B57	B10	B10	B28	B10	B10				
		B12	B31	B62	B12	B12	B31	B12	B12				
		B14	B35	B66	B14	B14	B35	B14	B14				
		B17	B38	B72	B17	B17	B38	B17	B17				
		B20	B42	B85	B20	B20	B42	B20	B20				
		B22	B45		B22	B22	B45	B22	B22				
		B25	B50		B25	B24	B50	B24	B24				
		B28			B28	B25		B25	B25				
		B31			B31	B28		B28	B28				
						B31		B31	B31				
						B35		B35	B35				
						B38		B38	B38				
						B42		B42	B42				
						B45		B45	B45				
						B50		B50	B50				

