

# RYCO



**Q RAM**  
RYCO ASSET MANAGEMENT SYSTEM

[www.RYCO.com.au](http://www.RYCO.com.au)





## RYCO. THE COMPANY.

RYCO Hydraulics started manufacturing hoses, fittings and filters in 1946. As the hydraulics industry evolved, the Company expanded its range and the main product line soon became high-pressure hydraulic hose and fittings.

RYCO Hydraulics' simple belief of "Higher Technology Equals Greater Performance" applies throughout the Company. The Company's research and development centres and testing facilities are dedicated to developing innovative products and pioneering new processes in fluid conveying systems technology. Our specialised equipment and technology enable us to manufacture our large range of products efficiently and cost effectively.

**"HIGHER TECHNOLOGY EQUALS GREATER PERFORMANCE"**

## RYCO. MISSION STATEMENT.

Our Mission is to listen to our customers and deliver the highest quality and technologically superior fluid conveying connection products and solutions.

## RYCO. COMPANY VISION.

Our vision is to be the premier supplier and service provider of choice in every market we participate in.

## RYCO. THE QUALITY.

RYCO Hydraulics is certified to current version of ISO 9001 "Quality Management Systems - Requirements" by bsi. British Standards Institute (Certificate No. FS 604893). Company Policy is to supply products and services that meet or exceed our industry standards. These standards include SAE, EN (DIN), AS, ISO, JIS, BS and BCS. The bottom line in Quality Control (QC) & Quality Assurance (QA) is Customer Confidence & Customer Satisfaction.

**OUR AIM IS ZERO DEFECTS**

## RYCO. PRODUCT IDENTIFICATION.

All RYCO Hydraulics products are clearly branded with a unique RYCO Hydraulics part number and batch code, where practical. In today's quality conscious world, RYCO's invaluable batch coding system takes traceability and customer assurance to new levels. Not everyone is an expert in thread identification. Time and money are often wasted identifying goods or despatching the wrong item. Using clearly branded RYCO products reduces the chance of error, saving you time and money.

**IF IT'S NOT BRANDED - IT'S NOT RYCO**

## RYCO. WAREHOUSE & DISTRIBUTION.

At RYCO Hydraulics, we understand that when you need your product, you need it fast. Our network of warehouses and distributors gives the greatest product availability to our customers. Our comprehensive ordering and despatch system ensures that your orders are correct before leaving the warehouse.

**WE PRIDE OURSELVES ON SHIPPING CORRECTLY**

**DISCLAIMER:** We reserve the right to alter the design, or discontinue any of the company's products or services without notice. While every effort has been made to ensure the accuracy of the information contained in this publication, our Company Policy of continual research and product development necessitates changes and refinements which may not be reflected in the following pages. If in doubt, please contact your nearest sales office. Illustrations are not to scale, and are indicative only.

**COPYRIGHT 2018.** All rights reserved. This document may NOT be reproduced, in whole or parts, without the written permission of RYCO Hydraulics Pty. Ltd. Specifications may change without notice. E. & O.E.

**RYCO TERMS OF SALE.** Please refer to [www.RYCO.com.au](http://www.RYCO.com.au) for RYCO's Terms of Sale.

# INTRODUCTION

## HOW TO USE THIS BOOK

### HOW TO USE THE RYCO PRODUCT TECHNICAL MANUAL

This Product Technical Manual is divided into four colour coded sections; **Introduction**, **Hose**, **Couplings** and **Technical**.

A colour coded indicator tab on the edge of every right hand page aids finding and identifying each section.

On pages 4 and 5 is an **Alphanumeric Index** if you know the Part Number you're looking for, and pages 6 to 7 provide a Contents by Section that lists the product ranges each section contains.

In addition, each section contains a **Contents** and/or **Pictorial Index** as relevant to further aid you in finding the exact information you require. In addition to a Contents and Pictorial Index, the **Couplings** section also contains an **Index by Endstyle Number**.

### IMPORTANT – DO NOT MIX AND MATCH PRODUCT

Hydraulic Hose from one manufacturer is usually not compatible with fittings supplied by another manufacturer.

It is the responsibility of the hose assembly fabricator to consult the manufacturer's written assembly instructions or the manufacturers directly before intermixing hose and fittings from two manufacturers. Similarly, assembly equipment from one manufacturer is usually not interchangeable with that of another manufacturer. It is the responsibility of the hose assembly fabricator to consult the manufacturer's written instructions or the manufacturers directly for the proper assembly equipment. Always follow the manufacturer's instructions for proper preparation and fabrication of hose assemblies.



## SAFETY GUIDE

### FOR THE SELECTION AND USE OF HOSE, FITTINGS AND RELATED ACCESSORIES

**Failure or improper selection or improper use of hose, fittings, or related accessories can cause death, personal injury and property damage. Possible consequences of failure or improper selection or improper use of hose, fittings, or related accessories include, but are not limited to:**

- Fittings blown off at high speed.
- High velocity fluid discharge.
- Explosion, or burning, of the conveyed fluid.
- Electrocution from high voltage electric power lines or other sources of electricity.
- Contact with suddenly moving, or falling, objects that are held in position, or moved, by conveyed fluid.
- Injections by high-pressure fluid discharge.
- Dangerously whipping hose.
- Contact with conveyed fluids that may be hot, cold, toxic or otherwise injurious.
- Sparking or explosion caused by static electricity build-up.
- Sparking, or explosion, while spraying paint or other flammable liquid.

## THE COMPANY

An Australian-owned company, RYCO has built a strong reputation since it commenced manufacturing of hydraulic hose and fittings in Melbourne, Australia back in 1946.

Engineering excellence, customer-focus and highest quality products continue to attract new customers, from varied industries right across the world.

RYCO Research & Development centres are dedicated to improving product and pioneering new technologies and processes in fluid conveying systems. RYCO quality range of hydraulic hose and fittings is supported by a network of loyal and committed distributors across the world.

RYCO products supplied to a wide range of industries including mining, construction, utilities, defence, marine, oil & gas, OEMs and more. RYCO continue to expand its product range to meet growing needs of worldwide hydraulic industry.

## GLOBAL RESOURCES

In today's competitive international business environment, the requirements for suppliers and customers to work closely together are greater than ever before.

RYCO has expanded its horizons and developed its manufacturing and distribution business on a global scale, working with industries in diverse sectors. RYCO has offices and warehouses strategically placed in Europe, Africa, China, New Zealand, South and North America and fully Quality Accredited manufacturing centres in Australia, China and Malaysia.

With such an extensive global footprint, RYCO can ensure quality product is delivered to our customers, whenever and wherever required.

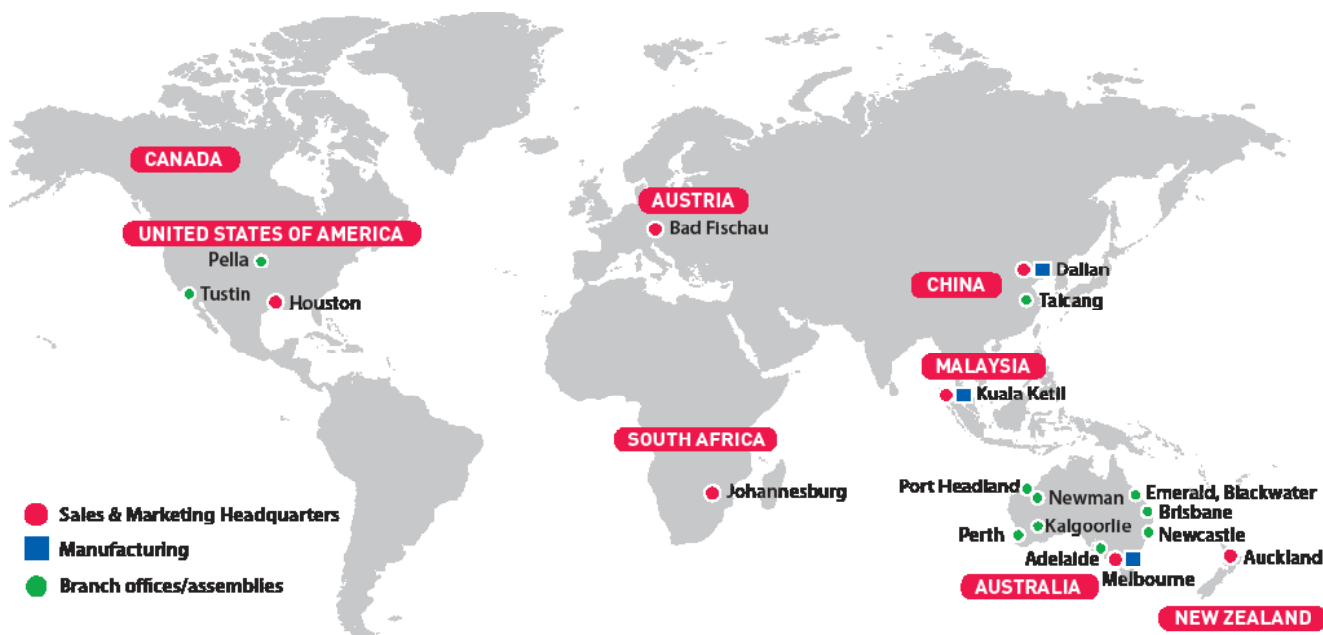

INTRODUCTION

HOSE

COUPLINGS

ADAPTORS

TECHNICAL

# INTRODUCTION

## ALPHANUMERIC INDEX

14.....	456	8010.....	325	H6000S.....	81	RW813.....	458	S29N.....	417	S87.....	431
15.....	456	8020.....	324	JCD.....	453	RW822.....	459	S31.....	403	S88.....	430
16.....	456	8030.....	326	JCTD.....	453	RW823.....	460	S31N.....	417	S89.....	414
17.....	456	8040.....	327	JPD.....	453	RW824.....	459	S32N.....	417	S90.....	429
21.....	457	8050.....	325	JPPD.....	453	RW826.....	460	S33.....	449	S91.....	430
24.....	457	8060.....	325	JS4000/G.....	122	RW830.....	459	S34.....	449	S92.....	431
24A.....	457	8070.....	327	JS4000BX/GX.....	123	RW830.....	458	S35.....	449	S93.....	413
24B.....	457	8090.....	326	JS6000/G.....	124	RW831.....	460	S36.....	449	S94.....	414
24HA.....	457	8100.....	331	JS6000BX/GX.....	125	RW860.....	459	S37.....	449	S97.....	450
25.....	456	8111.....	325	K000.....	353	SHOCKWAVE.....	121	S39.....	403	S97AK.....	450
25HL.....	456	8180.....	330	L000.....	353	SRF.....	126	S39N.....	417	S94N.....	421
35B.....	404	8200.....	330	M000.....	353	SRX.....	127	S40.....	440	S95.....	414
37/37.....	427	8230.....	330	MBD.....	432	SA6.....	439	S40K.....	440	S95N.....	421
6010.....	341, 355, 361	8240.....	327	MS1000.....	117	SA7.....	412	S40M.....	441	S96.....	413
6020.....	341, 355	8530.....	328	M1.....	132	SA7N.....	421	S42.....	440	S96N.....	421
6024.....	357	8540.....	329	MCD.....	454	SA10.....	439	S42K.....	440	S100.....	425
6030.....	343, 363	8570.....	329	MPD.....	454	SA15.....	439	S42M.....	441	S101.....	429
6040.....	344, 354, 362, 364	8640.....	331	MP1.....	133	SA17.....	439	S43.....	402	S105.....	404
6050.....	358	8740.....	329	M2.....	134	SA18.....	439	S44.....	401	S106.....	434
6052.....	357	8900.....	328	M2G.....	135	SA19.....	440	S45.....	403	S107.....	429
6060.....	357	91.....	457	M6L.....	432	SA20.....	412	S46.....	402	S108.....	428
6070.....	345, 359	33010.....	334	M6S.....	432	SA23.....	439	S47.....	405	S109.....	428
6080.....	365	33020.....	333	M73.....	432	SA51.....	439	S47N.....	417	S110.....	428
6090.....	340, 343, 362, 360	33024.....	333	M75L.....	433	S1.....	443	S48.....	405	S111.....	434
6091.....	360	33040.....	336	M75S.....	433	S1.....	443	S48N.....	417	S112.....	431
6130.....	381	33090.....	335	M7.....	434	S143H.....	444	S49.....	403	S113.....	434
6150.....	380	33111.....	332	M7L.....	434	S146H.....	444	S49N.....	417	S115.....	434
6170.....	381	33130.....	337	M7S.....	434	S147H.....	444	S50.....	405	S116.....	436
6180.....	383	33150.....	337	M71L.....	435	S1H.....	443	S50N.....	417	S117.....	436
6200.....	352, 385	33170.....	338	M71S.....	434	S2H.....	443	S51.....	422	S118.....	436
6210.....	359	33200.....	338	M77L.....	433	S2L.....	443	S52.....	422	S116.....	436
6230.....	382, 352	33400.....	335	M77S.....	433	S3.....	443	S53.....	399	S119.....	413, 407, 437
6240.....	346, 367	33400N.....	335	L1.....	129	S3H.....	443	S53N.....	415	S120.....	437
6250.....	345, 366	33410.....	333	OCD.....	454	S4.....	425	S53P.....	399	S121.....	437
6260.....	342, 358	33420.....	338	OPD.....	454	S5.....	425	S54.....	399	S122.....	437
6270.....	342, 358	BBB.....	461	PL1D.....	130	S6.....	423	S56.....	422	S123.....	437
6280.....	346, 368	BBM.....	461	PL1PV.....	131	S6M.....	423	S57.....	422	S124.....	437
6320.....	355, 356	BT1.....	120	PPD.....	455	S6S.....	423	S58.....	399	S125.....	437
6320N.....	362	BCD.....	453	QRAM.....	163	S7.....	407	S59.....	399	S126.....	438
6340.....	356	BPD.....	453	R4SHD.....	108	SA8.....	412	S60.....	414	S127.....	438
6380.....	384	CS1000.....	118	R4SPD.....	107	S8.....	408	S61.....	407	S131.....	449
6390.....	385	C6000D.....	82	R4100.....	148	SA9.....	412	S62.....	426	S137.....	428
6530.....	349, 375	C6000S.....	83	R62C.....	455	SA9N.....	421	S63.....	426	S138.....	428
6540.....	349, 376	DF1D.....	84	RCSB/RCSR.....	153	S9N.....	419	S64.....	399	S140.....	440
6550.....	350, 377	DF2D.....	85	RH.....	156	S9.....	408	S64N.....	415	S140K.....	440
6560.....	350, 377	DK1D.....	86	RHYS.....	161	S9N.....	419	S65.....	422	S140M.....	441
6563.....	377	DK1E.....	87	RHYT/RHWT.....	164	S10.....	424	S65S.....	422	S141.....	436
6570.....	376	DK1S.....	88	RL21D.....	404	S11.....	408	S66.....	424	S142.....	440
6580.....	376	DK2D.....	89	RL20SH.....	461	S11N.....	419	S66F.....	424	S142K.....	440
6600.....	369	DK2E.....	90	RO-BP.....	404	S12.....	431	S67.....	427	S142M.....	441
6630.....	255	DK2S.....	91	ROD-AC.....	451	S13.....	425	S68.....	427	S148.....	450
6640.....	383	D2B.....	115	ROD-BP.....	451	S15.....	425	S69.....	410	S152.....	422
6650.....	369	E1.....	96	ROD-DL.....	451	S16.....	407	S70.....	410	S154.....	436
6660.....	369	E2.....	97	ROD-DS.....	451	S17.....	424	S71.....	409	S162.....	450
6670.....	370	EC1.....	93	ROD-FS.....	451	S18.....	425	S72.....	400	S163.....	450
6680.....	368	EC2.....	94	ROD-SF.....	452	S19.....	426	S72N.....	416	S167.....	405
6711.....	371	ECP1.....	95	ROD-UN.....	452	S20.....	411	S73.....	399	S180.....	412
6720.....	372	FC61D.....	455	ROD-WD/ROD-BE.....	452	S20N.....	421	S74.....	409	S181.....	412
6730.....	372	FC62D.....	455	RQP1.....	111	S21.....	411	S75.....	401	S940.....	445
6740.....	350, 378	FK61.....	444	RQP2.....	112	S21N.....	420	S76.....	410	S940F.....	445
6750.....	351, 378	FK61M.....	444	RQP5.....	113	S23.....	424	S77.....	404	S940FM.....	445
6760.....	379	FK62.....	444	RQP6.....	114	S24.....	400	S78.....	411	S941.....	445
6770.....	351, 379	FK62M.....	444	RSG.....	157, 158	S24N.....	415	S79.....	411	S941F.....	445
6780.....	378	FS1072.....	150	RSGF.....	157	S25.....	403	S80.....	400	S941FM.....	445
6790.....	378	H12D.....	105	RSGY.....	157	S25N.....	417	S80N.....	416	S951.....	447
6800.....	347, 373	H12S.....	106	RTH1.....	130	S49.....	403	S81.....	401	S951F.....	447
6810.....	347, 374	H3000D.....	73	RWA.....	159	S49N.....	417	S81N.....	416	S951FM.....	447
6820.....	374, 348	H3000S.....	74	RW721.....	459	S26.....	401	S82.....	403	S952.....	447
6830.....	348, 375	H4000D.....	75	RW722.....	458	S26N.....	416	S82N.....	417	S952F.....	447
6850.....	384	H4000S.....	76	RW723.....	458	S27.....	400	S83.....	405	S952FM.....	447
6860.....	359	H5000C.....	77	RW725.....	459	S27N.....	416	S84.....	403	S953.....	447
6861.....	359	H5000D.....	78	RW726.....	460	S28.....	403	S84N.....	417	S954.....	447
6960B.....	361	H5000S.....	79	RW727.....	459	S28N.....	417	S85.....	413	S957.....	448
750/760.....	162	H6000D.....	80	RW811.....	458	S29.....	406	S86.....	430	S958.....	448



S970.....	446	T2480.....	223	T4250.....	239	T6454.....	263	T7350.....	295	TP475.....	305
S970F.....	446	T2482.....	223	T4251.....	239	T6455.....	264	T7353.....	298	TP501.....	311
S970FM.....	446	T2483.....	223	T4260.....	234	T6350.....	264	T7354.....	298	TP510.....	311
S971.....	446	T2501.....	211	T4280.....	240	T6353.....	264	T7360.....	295	TP520.....	311
S971F.....	446	T2510.....	211	T4281.....	240	T6354.....	265	T7363.....	299	TP540.....	316
S971FM.....	446	T2520.....	212	T4320N.....	236	T6355.....	265	T7364.....	299	TP570.....	316
S976.....	446	T2530.....	224	T4320.....	233	T6359.....	265	T7370.....	296	TP630.....	312
S976F.....	446	T2540.....	225	T4340.....	234	T6465.....	265	T7373.....	300	TP640.....	314
S977.....	446	T2570.....	225	T4501.....	242	T6360.....	266	T7374.....	300	TP643.....	314
S970.....	446	T2580.....	225	T4530.....	245	T6914.....	266	T7378.....	299	TP646.....	314
S977F.....	442	T2600.....	209	T4540.....	245	T6916.....	266	T7440.....	297	TP650.....	310
S980.....	442	T2610.....	210	T4550.....	245	T6918.....	267	T7443.....	296	TP711.....	312
S981.....	442	T2630.....	213	T4560.....	246	T6363.....	267	T7444.....	297	TP720.....	313
S982.....	442	T2640.....	229	T4570.....	245	T6364.....	267	T7450.....	295	TP730.....	313
S982C.....	442	T2650.....	208	T4600.....	241	T6374.....	268	T7453.....	297	TP7.....	138
S967.....	445	T2660.....	209	T4660.....	241	T6460.....	268	T7454.....	297	TP7N.....	139
S968.....	445	T2670.....	210	T4670.....	242	T6463.....	268	T7460.....	295	TP7T.....	140
T1D.....	98	T2680.....	206	T4740.....	246	T6464.....	268	T7463.....	298	TP7TN.....	141
T1F.....	98	T2682.....	206	T4750.....	246	T6375.....	269	T7464.....	298	TP8.....	142
T1S.....	99	T2683.....	206	T4770.....	246	T6370.....	269	T7480.....	289	TP8N.....	143
T2C.....	103	T2711.....	214	T4800.....	243	T6373.....	269	T7482.....	289	TP8T.....	144
T2D.....	101	T2720.....	215	T4810.....	244	T6375.....	269	T7483.....	289	TP8TN.....	145
T2S.....	102	T2730.....	216	T4820.....	244	T6370.....	269	T7501.....	283	TP800.....	315
T5.....	116	T2740.....	225	T4830.....	244	T6375.....	269	T7510.....	283	TP810.....	315
T2010.....	187	T2750.....	226	T4840.....	243	T6936.....	270	T7520.....	283	TP820.....	315
T2013.....	188	T2760.....	226	T4850.....	249	T6932.....	270	T7630.....	284	TP3000.....	146
T2017.....	189	T2770.....	226	T4870.....	247	T6930.....	270	T7640.....	300	TPGL.....	147
T2020N.....	199	T2780.....	226	T5000D.....	69	T6933.....	270	T7643.....	300	TT010.....	317
T2020.....	190	T2790.....	226	T5000S.....	70	T61502.....	271	T7680.....	282	TT020.....	317
T2024.....	192	T2800.....	219	T6000D.....	71	T61501.....	271	T7711.....	285	TT030.....	318
T2028B.....	192	T2801.....	219	T6000S.....	72	T7010.....	272	T7720.....	285	TT040.....	319
T2030.....	200	T2810.....	220	T6010.....	250	T7013.....	273	T7730.....	285	TT050.....	318
T2031.....	200	T2811.....	220	T6013.....	250	T7014.....	272	T7800.....	286	TT090.....	320
T2040.....	201	T2820.....	221	T6020.....	251	T7020N.....	278	T7810.....	287	TT240.....	319
T2041.....	201	T2821.....	221	T6022.....	251	T7020.....	275	T7820.....	287	TT250.....	319
T2050.....	196	T2823.....	220	T6270.....	273	T7022.....	273	T7823.....	287	TT260.....	318
T2057.....	196	T2824.....	220	T6260.....	251	T7027.....	275	T7830.....	287	TT320.....	241
T2060.....	193	T2830.....	221	T6030.....	252	T7030.....	278	T7840.....	286	TT540.....	320
T2070.....	202	T2831.....	221	T6040.....	253	T7040.....	279	T7870.....	288	TT600.....	320
T2071.....	202	T2840.....	218	T6045.....	253	T7041.....	279	T7871.....	288	TT670.....	320
T2080.....	202	T2850.....	231	T6250.....	253	T7045.....	279	T7872.....	288	TXA2D.....	104
T2081.....	202	T2861.....	200	T6280.....	254	T7050.....	274	T7876.....	288	TW4027.....	323
T2090.....	197	T2870.....	222	T6240.....	254	T7057.....	275	T7900.....	283	TW4090.....	323
T2091.....	197	T2871.....	222	T6900.....	254	T7060.....	274	T7910.....	294	TW4711.....	323
T2122.....	205	T2872.....	222	T6630.....	255	T7070.....	280	T7930.....	296	V010.....	341
T2130.....	227	T2900.....	206	T6711.....	255	T7080.....	280	T7933.....	300	V020.....	341
T2150.....	227	T2940.....	221	T6720.....	255	T7090.....	277	T71501.....	302	V030.....	343
T2170.....	228	T2950.....	221	T6730.....	255	T7091.....	277	T71502.....	302	V040.....	344
T2180.....	229	T3000D.....	62	T6840.....	256	T7122.....	282	TG010.....	321	V070.....	345
T2190.....	199	T3000S.....	63	T6800.....	256	T7130.....	290	TG020.....	321	V090.....	343
T2200.....	231	T3600C.....	64	T6810.....	256	T7140.....	290	TG020N.....	322	V200.....	352
T2210.....	195	T3600D.....	65	T6811.....	256	T7150.....	291	TG030.....	322	V230.....	352
T2220.....	205	T3600S.....	66	T6820.....	257	T7160.....	292	TG040.....	322	V240.....	346
T2230.....	228	T4000D.....	67	T6870.....	257	T7170.....	293	TG090.....	321	V250.....	345
T2240.....	204	T4000S.....	68	T6876.....	257	T7171.....	293	TG320.....	321	V260.....	342
T2241.....	204	T4010.....	233	T6871.....	257	T7172.....	293	TG320N.....	321	V270.....	342
T2243.....	203	T4013.....	233	T6872.....	257	T7173.....	293	TG640.....	322	V280.....	346
T2243.....	203	T4020N.....	236	T6130.....	258	T7174.....	294	TJ2D.....	110	V530.....	349
T2250.....	203	T4020.....	233	T6140.....	258	T7200.....	302	TP010.....	303	V540.....	349
T2251.....	203	T4030.....	237	T6290.....	258	T7210.....	275	TP020.....	304	V550.....	350
T2260.....	194	T4040.....	238	T6150.....	259	T7230.....	301	TP020N.....	307	V560.....	350
T2267.....	196	T4041.....	238	T6300.....	259	T7240.....	281	TP030.....	307	V740.....	350
T2270.....	194	T4050.....	234	T6170.....	260	T7243.....	281	TP031.....	307	V750.....	351
T2277.....	196	T4090.....	236	T6330.....	261	T7245.....	281	TP040.....	308	V770.....	351
T2280.....	204	T4122.....	241	T6333.....	261	T7250.....	280	TP050.....	304	V800.....	347
T2281.....	204	T4130.....	248	T6334.....	261	T7260.....	274	TP090.....	306	V810.....	347
T2320N.....	198	T4150.....	248	T6335.....	261	T7264.....	276	TP122.....	304	V820.....	348
T2320.....	191	T4170.....	248	T6912.....	261	T7270.....	276	TP240.....	309	V830.....	348
T2340N.....	198	T4173.....	248	T6440.....	262	T7277.....	276	TP250.....	309		
T2340.....	191	T4200.....	249	T6445.....	262	T7280.....	282	TP260.....	304		
T2380.....	231	T4230.....	247	T6443.....	262	T7290.....	292	TP270.....	305		
T2390.....	232	T4240.....	238	T6444.....	263	T7300.....	291	TP280.....	310		
T2470.....	217	T4241.....	238	T6450.....	263	T7330.....	294	TP340N.....	306		
T2475.....	193	T4243.....	240	T6453.....	263	T7333.....	296	TP470.....	313		

# INTRODUCTION

## CONTENTS BY SECTION

### OVERVIEW OF CONTENTS AND INDICES BY SECTION

<b>INTRODUCTION</b> .....	<b>1-34</b>
Alphanumeric Index.....	4-5
<b>HOSE</b> .....	<b>35-165</b>
Hose Pictorial Index.....	36-42
<b>COUPLINGS</b> .....	<b>166-385</b>
Contents.....	167
Pictorial Index.....	171-180
Index by Endstyle Number.....	181-185
<b>ADAPTORS</b> .....	<b>386-461</b>
Contents.....	387
Pictorial Index.....	391-398
<b>TECHNICAL</b> .....	<b>462-515</b>
Contents.....	463



### INTRODUCTION

1-34

<b>INTRODUCTION</b> .....	<b>1-34</b>
RYCO. The Company .....	1
RYCO. Mission statement.....	1
RYCO. Company Vision.....	1
RYCO. The Quality.....	1
RYCO. Product Identification.....	1
RYCO. Warehouse & Distribution.....	1
RYCO. Disclaimer, Copyright & Terms of Sale.....	1
<b>HOW TO USE THIS BOOK</b> .....	<b>2</b>
How to use the RYCO Product Technical Manual.....	2
Important – Do not mix and match product.....	2
<b>ABOUT RYCO – THE COMPANY AND GLOBAL RESOURCES</b> .....	<b>3</b>
<b>ALPHANUMERIC INDEX</b> .....	<b>4-5</b>
<b>CONTENTS BY SECTION</b> .....	<b>6-8</b>
<b>ABOUT RYCO - POLICIES</b> .....	<b>10-11</b>
Quality Policy.....	10
Occupational Health and Safety Policy.....	11
Environmental Policy.....	11
Quality Accreditation.....	12-13
OEM.....	14-15
Mining.....	17
MDG 41, MDG 15.....	18
Matched Solutions.....	18
Safety Solutions.....	19
Innovation.....	20
<b>ABOUT RYCO – SERVICES AND SUPPORT</b> .....	<b>21-26</b>
Training .....	21
QRAM - RYCO Asset Management System.....	22
HALP® - Hose Assembly Lifespan Predictor.....	23
RYCO 24•7 - Mobile hose and fitting service.....	25
RYCO 24•7 Mission Statement.....	25
RYCO 24•7 SERVICES.....	26
Onsite Hose Containers.....	26
<b>RYCO EXPERIENCE</b> .....	<b>27</b>
Hydraulic Hose and Coupling Tolerancing.....	27
RYCO Safety Zone.....	28
<b>IMPORTANT INFORMATION: HOSE COUPLING PART NUMBER CHANGES</b> .....	<b>29</b>
<b>DASH SIZE PART NUMBERING</b> .....	<b>30-34</b>
Metric and imperial nut sizing.....	31
Quick reference chart of dash size equivalents.....	34

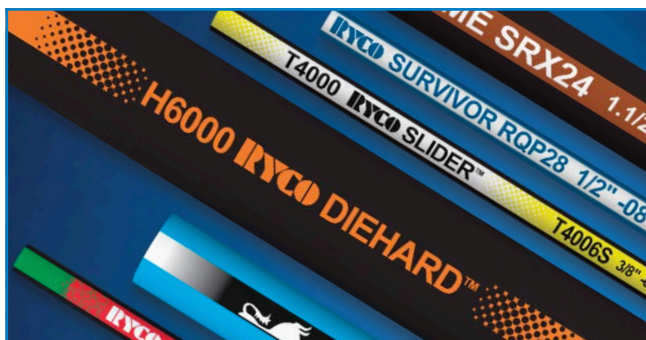

**HOSE**

**35-165**



**COUPLINGS**

**166-385**

INTRODUCTION

HOSE

COUPLINGS

ADAPTORS

TECHNICAL

<b>PICTORIAL INDEX</b> .....	<a href="#">36-42</a>
<b>HOSE TYPE APPROVALS</b> .....	<a href="#">44-48</a>
<b>HOSE COVERS</b> .....	<a href="#">52-53</a>
<b>SPECIFICATIONS SUMMARY</b> .....	<a href="#">55-58</a>
Impulse Life, Flame Resistance, Minimum Bend Radius, Anti-Static, Non conductive, Skive/Non-Skive, Outside Diameters.....	<a href="#">57</a>
Safety Guide – Maximum Temperature Limits.....	<a href="#">58</a>
<b>ISOBARIC BRAID</b> .....	<a href="#">62-72</a>
T3000D, T3000S, T3600C, T3600D, T3600S, T4000D, T4000S, T5000D, T5000S, T6000D, T6000S	
<b>ISOBARIC SPIRAL</b> .....	<a href="#">73-83</a>
H3000D, H3000S, H4000D, H4000S, H5000C, H5000D, H5000S, H6000D, H6000S, C6000D, C6000S	
<b>BRAID</b> .....	<a href="#">84-104</a>
DF1D, DF2D, DK1D, DK1E, DK1S, DK2D DK2E, DK2S, EC1, EC2, ECP1, E1, E2, T1D, T1S, T1F, T2D, T2S, T2C, TXA2D, H12D, H12S	
<b>SPIRAL</b> .....	<a href="#">105-108</a>
H12D, H12S, R4SPD, R4SHD.....	<a href="#">108</a>
<b>JACK HOSE ASSEMBLIES</b> .....	<a href="#">109</a>
<b>SPECIALTY AND HIGH TEMPERATURE</b> .....	<a href="#">110-120</a>
TJ2D, RQP1, RQP2, RQP5, RQP6, D2B, T5, MS1000, CS1000, BT1.....	<a href="#">119</a>
<b>VERY HIGH PRESSURE WATERBLAST</b> .....	<a href="#">121</a>
SW.....	<a href="#">121</a>
<b>PRESSURE WASHER</b> .....	<a href="#">122-125</a>
JS4000G/BX/GX, JS6000G/BX/GX.....	<a href="#">124</a>
<b>SUCTION &amp; RETURN</b> .....	<a href="#">125-127</a>
<b>SRF, SRX</b> .....	<a href="#">126</a>
<b>TEFLON</b> .....	<a href="#">127</a>
RTH1.....	<a href="#">127</a>
<b>TEXTILE BRAID</b> .....	<a href="#">130-135</a>
PL1, PL1D, PL1PV, M1, MP1, M2, M2G.....	<a href="#">134</a>
<b>THERMOPLASTIC</b> .....	<a href="#">138-146</a>
TP7, TP7N, TP7T, TP7TN, TP8, TP8N, TP8T, TP8TN, TP3000.....	<a href="#">145</a>
<b>GREASING AND LUBRICATION</b> .....	<a href="#">147-148</a>
TPGL, R4100N.....	<a href="#">147</a>
<b>HOSE PROTECTION</b> .....	<a href="#">150-162</a>
FS1072, RCS, RH,RSG, RWA, RHYS, 750/760 Spring Guard.....	<a href="#">162</a>
<b>HOSE TRACKING – QRAM HOSE LABEL</b> .....	<a href="#">163-164</a>
QRAM, RHYT/RHWT.....	<a href="#">164</a>
<b>HOW TO ORDER RYCO HYDRAULIC HOSE</b> .....	<a href="#">165</a>

<b>CONTENTS</b> .....	<a href="#">167</a>
<b>INFORMATION</b> .....	<a href="#">168-170</a>
RYCO T2000, T4000, T6000 AND T7000 SERIES COUPLINGS.....	<a href="#">170</a>
<b>PICTORIAL INDEX</b> .....	<a href="#">171-180</a>
<b>INDEX BY END STYLE NUMBER</b> .....	<a href="#">181-185</a>
<b>WORKING PRESSURE OF HOSE ASSEMBLIES</b> .....	<a href="#">186</a>
<b>DROP LENGTH &amp; CUT-OFF ALLOWANCE DIMENSIONS FOR COUPLINGS</b> .....	<a href="#">186</a>
<b>T2000 SERIES</b> one-piece crimp couplings.....	<a href="#">187</a>
<b>T4000 SERIES</b> one-piece crimp couplings.....	<a href="#">233</a>
<b>T6000 SERIES</b> one-piece crimp couplings.....	<a href="#">250</a>
<b>T7000 SERIES</b> one-piece crimp couplings.....	<a href="#">272</a>
<b>TP000 SERIES</b> one-piece crimp couplings.....	<a href="#">303</a>
<b>TT000</b> One-piece crimp couplings.....	<a href="#">317</a>
<b>TG000</b> One-piece crimp couplings.....	<a href="#">321</a>
<b>TW000</b> One-piece crimp couplings.....	<a href="#">323</a>
<b>8000 SERIES</b> Push-On Couplings.....	<a href="#">324</a>
<b>33000 SERIES</b> Suction and Return Couplings.....	<a href="#">332</a>
<b>V000 SERIES</b> Field Attachable Couplings.....	<a href="#">339</a>
Additional Coupling End Styles.....	<a href="#">339</a>
Cut-Off Allowance (CA) Dimensions for Field Attachables.....	<a href="#">339</a>
How To Order RYCO V Series Field Attachable Couplings.....	<a href="#">340</a>
How To Order RYCO Field Attachable Couplings.....	<a href="#">354</a>
<b>V000 SERIES</b> Field Attachable Inserts.....	<a href="#">355</a>
<b>6000 SERIES FIELD ATTACHABLE INSERTS</b> .....	<a href="#">355-385</a>

# INTRODUCTION

## CONTENTS BY SECTION



### ADAPTORS

386-461



### TECHNICAL

462-515

<b>CONTENTS</b> .....	<a href="#">387</a>
<b>FINDING ADAPTORS</b> .....	<a href="#">388</a>
Rule 1. Alphabetical Rule.....	<a href="#">388</a>
Rule 2. Mixture Rule.....	<a href="#">388</a>
Rule 3. Number Of Ends Rule.....	<a href="#">388</a>
Other ways to quickly find an Adaptor.....	<a href="#">388</a>
<b>DASH SIZE NUMBERING RULES</b> .....	<a href="#">389-390</a>
<b>PICTORIAL INDEX</b> .....	<a href="#">391-398</a>
<b>ADAPTOR PRODUCTS</b> .....	<a href="#">399-450</a>
BSP Adaptors.....	<a href="#">399-414</a>
NPT Adaptors.....	<a href="#">415-421</a>
JIC Adaptors.....	<a href="#">422-431</a>
Joiner.....	<a href="#">431</a>
Metric Adaptors.....	<a href="#">432-435</a>
ORFS Adaptors.....	<a href="#">435-438</a>
SAE Adaptors.....	<a href="#">439-444</a>
SAE Flange Blocks.....	<a href="#">444-448</a>
Swivel Joint Adaptors.....	<a href="#">449</a>
UNO adaptors.....	<a href="#">450</a>
<b>MISCELLANEOUS</b> .....	<a href="#">451-461</a>
O Rings.....	<a href="#">451-452</a>
Plastic Caps And Plugs.....	<a href="#">358-455</a>
Tube Bends.....	<a href="#">456-457</a>
RYCO WEO Adaptors.....	<a href="#">458-460</a>
<b>ACCESSORIES</b> .....	<a href="#">461</a>

<b>CONTENTS</b> .....	<a href="#">463</a>
<b>HOSE SIZE SELECTION NOMOGRAPH</b> .....	<a href="#">464</a>
<b>HOW TO ORDER HOSE ASSEMBLIES</b> .....	<a href="#">465</a>
How To order hose assemblies, Cut-Off Allowance (CA).....	<a href="#">466</a>
<b>HOSE SELECTION</b> .....	<a href="#">467-468</a>
Safety Guide.....	<a href="#">469</a>
Safety Guide – Maximum Temperature Limits.....	<a href="#">472-473</a>
<b>CHARACTERISTICS OF HOSE ELASTOMERS</b> .....	<a href="#">474</a>
<b>CHEMICAL COMPATIBILITY FOR HOSE</b> .....	<a href="#">475</a>
<b>HOSE ASSEMBLY GUIDES</b> .....	<a href="#">476-493</a>
Field Attachable Non-Skive Hose Assembly.....	<a href="#">476</a>
Field Attachable Skive Hose Assembly.....	<a href="#">477</a>
Non-Skive Hose Assembly.....	<a href="#">478</a>
Skive Hose Assembly.....	<a href="#">479</a>
Assembly Instructions – RTH1 Hoses.....	<a href="#">480</a>
Assembly Instructions – SRX & SRF Hoses.....	<a href="#">481</a>
Push-On Hose Assembly.....	<a href="#">482</a>
Assembly Instructions – TP7T, TP7TN, TP8T and TP8TN Twin Hose.....	<a href="#">483</a>
Tube Flaring Dimensions – 37° JIC and 45° SAE.....	<a href="#">484</a>
Assembly Instructions – Tube Bite Hose Couplings (End Style 850).....	<a href="#">486</a>
Assembly Instructions – S134 J-LOK Flareless Tube Fittings.....	<a href="#">488</a>
Hose Assembly – Installation Guide.....	<a href="#">490</a>
Factor Of Safety - Hose Assemblies.....	<a href="#">493</a>
<b>GUIDE TO THREAD AND CONNECTOR WORKING PRESSURES</b> .....	<a href="#">494-498</a>
WORKING PRESSURES - Adaptors, Hose Couplings and Hose Assemblies.....	<a href="#">494</a>
Guide to Thread and Connector Working Pressures.....	<a href="#">498</a>
<b>IMPORTANT NOTE REGARDING THREAD DASH SIZE/TUBE DASH SIZE</b> .....	<a href="#">499-500</a>
TUBE Dash Size – THREAD Dash Size.....	<a href="#">499</a>
<b>THREAD AND CONNECTOR IDENTIFICATION</b> .....	<a href="#">500</a>
How to Use this Section.....	<a href="#">500</a>
Thread ID Mate.....	<a href="#">500</a>
<b>THREAD AND CONNECTOR IDENTIFICATION</b> .....	<a href="#">501-512</a>
<b>TORQUE ASSEMBLY VALUES</b> .....	<a href="#">513</a>
<b>ABBREVIATIONS</b> .....	<a href="#">515</a>





INTRODUCTION

HOSE

COUPLINGS

ADAPTORS

TECHNICAL

## RYCO QUALITY, SAFETY AND ENVIRONMENTAL POLICIES

RYCO's mission is to exceed our customers', shareholders, stakeholders' and employee expectations through continuous improvement.

We are driven by innovation, teamwork and the integrity of our people whilst embracing community, cultural and Quality, Environmental and Health and Safety (QEHS) awareness. RYCO achieve this objective through the integration of the QEHS Management System into day-to-day operations of all of the company's facilities.

**WE ARE DRIVEN BY INNOVATION, TEAMWORK AND THE  
INTEGRITY OF OUR PEOPLE.**

# INTRODUCTION

## ABOUT RYCO – POLICIES

### QUALITY POLICY

RYCO specialises in the design, manufacture, distribution and sales of a comprehensive range of high pressure hydraulic hoses and fittings. The Company operates on a global scale and its products service a wide range of industrial applications.

Since 1946 RYCO has established an enviable reputation for expertise, service, quality and delivery.

RYCO's Mission is to exceed our customers', shareholders', suppliers' and employees' expectations through continuous improvement driven by innovation, teamwork and the integrity of our people whilst embracing community, cultural and environmental awareness.

RYCO's Quality system and policy requires compliance with applicable industry standards, statutory regulations, world best practice philosophy, value added processes, service and efficiency.

RYCO Management shall ensure that suitable infrastructure and resources are provided and utilised to guarantee Quality is not compromised.

Quality is the responsibility of all RYCO personnel.

The RYCO Quality System is based on "ISO 9001, Quality Management Systems - Requirements".



**QUALITY IS THE RESPONSIBILITY OF ALL RYCO PERSONNEL.**

## OCCUPATIONAL HEALTH AND SAFETY POLICY

RYCO specialises in the design, manufacture and sales of a comprehensive range of high pressure hydraulic hoses and fittings. The Company operates on a global scale and its products service a wide range of industrial applications.

RYCO is committed to protecting the health and safety of employees, contractors, visitors and the general public in the workplace. RYCO shall fulfil this commitment through a health and safety management system that is integrated with RYCO's business activities related to products, services and people.

RYCO employees, contractors and visitors have a duty of care to take reasonable care for their own health and safety and for the health and safety of persons who may be affected by their actions and inactions in the workplace.

RYCO will take reasonably practical steps to improve workplace health and safety conditions and to prevent injury and illness to its employees, contractors, visitors and the general public.

This Policy applies to RYCO fixed and mobile workplaces and persons attending those workplaces. This Policy will be reviewed from time to time for Continuous Improvement, changes to legislation, industry best practices and policy directions within RYCO.



## ENVIRONMENTAL POLICY

RYCO specialises in the design, manufacture and sales of a comprehensive range of high pressure hydraulic hoses and fittings. The Company operates on a global scale and its products service a wide range of industrial applications.

RYCO is committed to compliance with applicable environmental legislation, regulations and any other requirements to which RYCO subscribes.

RYCO operates a program of continual improvement in environmental performance and pollution prevention, aiming to minimise the environmental impacts resulting from relevant activities.

This Policy applies to RYCO fixed and mobile workplaces and persons attending those workplaces. This Policy will be reviewed from time to time for Continuous Improvement, changes to legislation, industry best practices and policy directions within RYCO.





# INTRODUCTION

## ABOUT RYCO – QUALITY ACCREDITATION

### RYCO QUALITY ACCREDITATION

RYCO Hydraulics is certified to current version of ISO 9001 “Quality Management Systems - Requirements” by bsi. British Standards Institute (Certificate No. FS 604893). Company Policy is to supply products and services that meet or exceed our industry standards.

These standards include SAE, EN (DIN), AS, ISO, JIS, BS and BCS.

The bottom line in Quality Control (QC) & Quality Assurance (QA) is Customer Confidence & Customer Satisfaction.



**bsi.**

**Certificate of Registration**

QUALITY MANAGEMENT SYSTEM - ISO 9001:2015

This is to certify that: **RYCO Hydraulics / RYCO 24.7**  
19 Whitehall Street  
Footscray VIC 3011

Holds Certificate Number: **FS 604893**

and operates a Quality Management System which complies with the requirements of ISO 9001:2015 for the following scope:

Design, manufacture and supply of hydraulic hose assemblies, hose couplings, fittings, adaptors and pneumatic couplings and adaptors for the marine, mining, agricultural, automotive and general industries. RYCO 24/7 offers a complete mobile service and replacement facility for users of hoses and tubes in hydraulic and pneumatic systems. RYCO 24/7 mobile connector specialists provide on-call, onsite servicing for emergency breakdown and or repair maintenance work for hose and tube systems.

For and on behalf of BSI:   
Chris Cheung, Head of Compliance & Risk - Asia Pacific

Original Registration Date: 1995-04-06      Effective Date: 2018-08-10  
Latest Revision Date: 2018-08-29      Expiry Date: 2021-09-22

Page: 1 of 4

...making excellence a habit.™

This certificate was issued electronically and remains the property of BSI Group ANZ Pty Limited, ACN 078 659 211 and is bound by the conditions of contract. This certificate can be verified at [www.bsi-global.com/clientdirectory](http://www.bsi-global.com/clientdirectory). Printed copies can be validated at [www.bsi-global.com/ClientDirectory](http://www.bsi-global.com/ClientDirectory). Further clarifications regarding the scope of this certificate and the applicability of ISO 9001:2015 requirements may be obtained by consulting the organization. This certificate is valid only if provided original copies are in complete set.

Information and Contact: BSI, Kitemark Court, Davy Avenue, Knowlhill, Milton Keynes MK5 8PP. Tel: + 44 345 080 9000.  
BSI Assurance UK Limited, registered in England under number 7805321 at 389 Chiswick High Road, London W4 4AL, UK.  
Information and Contact: BSI Group ANZ Pty Limited, ACN 078 659 211; Suite 2, Level 7, 15 Talavera Road, Macquarie Park, NSW 2113  
A Member of the BSI Group of Companies.



- ✓ ISO 9001: Quality
- ✓ ISO 14001: Environment
- ✓ OHSAS 18001: Safety

AS/NZS ISO 9001  
A Company Policy.

COMMITTED TO CONTINUAL IMPROVEMENT



## RYCO QUALITY ACCREDITATION

RYCO Hydraulics is committed to the objective of zero defects.

As a manufacturer of quality hydraulic hose and fittings, RYCO Hydraulics ensures that our products are accredited by independent third party organisations.



**ABS**  
American Bureau of Shipping



**DNV-GL**  
DNV GL Group



**LR**  
Lloyd's Register



**MED**  
Marine Equipment Directive



**USCG**  
US Coast Guard



**DOT**  
Dept. of Transport (USA)



**GOST-R**  
GOST-R



**BUREAU VERITAS**  
Bureau Veritas



**RINA**  
Registro Italiano Navale



**KR**  
Korean Register



**CLASSNK**  
Nippon Kaiji Kyokai



**MDG 41**  
Mining Design Guide

RYCO Hydraulics recommends SAE J1273 as a guide to the selection, manufacture, installation and servicing of hydraulic hose assemblies. RYCO Hydraulics complies with and exceeds third party accreditations as well as international ISO and EN (DIN) standards.

RYCO Hydraulics specifically design and manufacture hydraulic hose and fittings to “match” each other for greater performance and safety. Use only hose assemblies that consist of RYCO “matched” hydraulic hose with RYCO “matched” fittings.

RYCO Hydraulics testing and evaluation processes guarantee the performance and quality required to meet the demands of today's applications to safely convey fluids at high pressure.

RYCO Hydraulics are proud members of, and contribute to, the world's main industry groups including:

- MSHA** U.S. Department of Labor, Mine Safety and Health Administration
- NAHAD** National Association of Hose and Accessories Distributors (USA)
- MA-KA** Mining Products Safety Approval and Certification (China)
- BSI** British Standard Initiative (AS/NZS ISO 9001)
- NFPA** National Fluid Power Association (USA)
- RMA** Rubber Manufacturers Association
- ABS** American Bureau of Shipping
- MED** Marine Equipment Directive
- AGA** Australian Gas Association
- MDG 41** Mining Design Guide
- SAE** SAE International
- LR** Lloyd's Register
- USCG** US Coast Guard
- KR** Korean Register
- DNV-GL** DNV GL Group

**RYCO HYDRAULICS COMPLIES WITH  
SAE J343, SAEJ517, AS3791  
STANDARDS AND WITH THE RELEVANT  
ISO, EN, BS AND DIN STANDARDS**

INTRODUCTION

HOSE

COUPLINGS

ADAPTORS

TECHNICAL

# OEM SUPPORT

We understand that our success is dependent upon our clients' success.

- ✓ Comprehensive engineering solutions
- ✓ QRAM - RYCO Asset Management
- ✓ Vendor managed stock
- ✓ Cost reduction programs
- ✓ Kanban supply
- ✓ JIT deliveries
- ✓ Reliable despatch

In today's competitive international business environment, the requirements for suppliers and clients to work closely together is greater than ever before. At RYCO we do more than simply supply our product; we listen to our clients as we understand that our success is dependent upon our clients' success.

We actively work with our clients; connecting partnerships across our broad range of services. In partnership we implement and support cost reduction programs, comprehensive engineering solutions, hose management systems, vendor managed stock, Kanban supply, JIT deliveries, asset management systems and reliable despatch; all of which combine to give higher technology and greater performance to our clients.

Our hydraulics technology and professional expertise is regularly required to solve problems arising from the often unique applications of our clients. The experience and knowledge gained from involvement in these special applications increase our service levels so we can provide a superior service to our clients.

Whether you are a manufacturer involved in the worldwide export market, a mining operation in a remote location, or a local distributor, talk to RYCO about "Connecting Partnerships" to enhance your business.







## PRODUCTION

RYCO owns and operates manufacturing facilities in Australia, Malaysia and China, producing a complete range of hydraulic hose and fittings for the world market.

Due to our continuous improvement and investment program, and our specialised equipment and technology, we are able to manufacture a large range of hose and fittings efficiently and cost effectively. Our focus on production development and flexible manufacturing systems guarantee that we continually increase production levels and standards.



## QUALITY

Improved safety and risk management are of prime concern in today's industries. RYCO design hydraulic hose and fittings that MATCH, enabling RYCO hose assemblies to exceed SAE or EN/DIN performance requirements.

RYCO is certified to ISO 9001: 2015 "Quality Management Systems – Requirements" by bsi - British Standards Institution (bsi – Certificate No. FS 604893) and ISO 9002 "Quality Systems for Production and Installation" by the Department of Defence (Australia).



## INNOVATION

RYCO's commitment to Innovation and Continuous Improvement ensures that we can deliver tomorrow's solutions today. We believe that our global strength in Engineering, Innovation and product development provide our customers a higher level of service and solutions that are unparalleled in the industry.

## SERVICE

A key service to our OEM customers is the onsite pre-production fluid routing service provided by RYCO 24•7 Mobile Connector Specialists.

RYCO 24•7 has extensive coverage specialising in mobile hydraulic hose, fittings, service and replacement 24 hours a day, 7 days a week.

RYCO 24•7 actively supports and services national contracts and Original Equipment Manufacturers (OEM) in industries covering the mining, agriculture, marine, construction, defence and industrial market sectors.

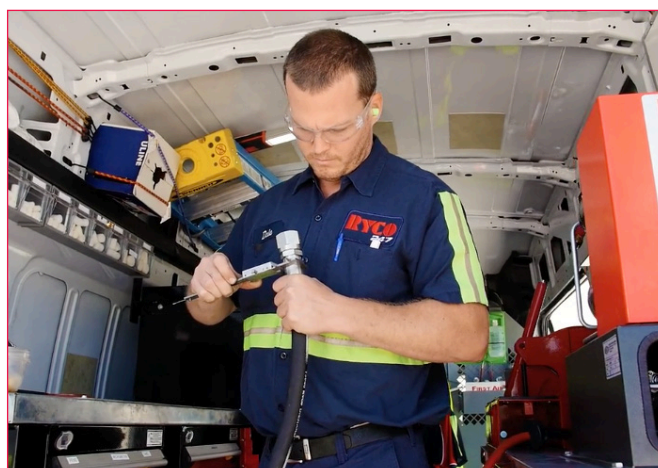



# INTRODUCTION

## ABOUT RYCO - MINING



**RYCO IS A SPECIALIST SUPPLIER OF HYDRAULIC HOSE AND FITTINGS TO THE MINING INDUSTRY WITH OVER 70 YEARS EXPERIENCE.**





INTRODUCTION

HOSE

COUPLINGS

ADAPTORS

TECHNICAL

## RYCO KNOW HOW

RYCO is a specialist supplier of hydraulic hose and fittings to the mining industry with over 70 years experience. Whether it is for heavy off-road mining vehicles, underground mining equipment at the coal face, lifting buckets of ore, or shifting mountains of overburden, you will find RYCO products hard at work.

RYCO has offices around the world and is committed to long term support of the resource industry on a global scale. **“Our People Are Our Greatest Asset”**. Dynamic and dedicated our teams bring together the best and most experienced people in the industry.

The focus is to continually improve on our current business activities and ensure we offer quality, technology and service to the resource industry, with safety being our prime objective.

## MINING

In today’s competitive international business environment the requirement for suppliers and clients to work closely together is greater than ever before; particularly in the resource industry. At RYCO we do more than simply supply a product; we understand that our success is dependent on our client’s success, safety and quality.

Our teams of field engineers pro actively work with our clients **“Connecting Partnerships”** across a broad scope of services to provide complete port to port solutions. The resulting fluid connection systems are designed to work. They are reliable. They are safe and can operate at their maximum potential.

RYCO is a solution based supplier providing our clients with a complete range of services including; on-time delivery; solving difficult engineering problems; cost reduction activities; on-site hose management systems and asset management. Many mining operations around the globe rely on RYCO’s extensive knowledge of the mining industry and RYCO’s large range of services to deliver them substantial cost reduction benefits.

# INTRODUCTION

## ABOUT RYCO – MDG-41 AND MDG-15 SAFE



### MDG 41

MDG 41 is a document which was created in response to an increasing number of incidents involving high-pressure fluid injection injuries on mine sites. In response to this, the NSW Department of Primary Industries (DPI) established a joint committee with involvement from the Mining Industry, Equipment Manufacturers, Repairers, and Suppliers of Fluid Power components in order to formulate a 'best practice' document. The result is Mechanical Design Guideline Number 41 (MDG 41).

The Mechanical Design Guidelines are a series of tools to assist companies in achieving compliance with the OH&S Act and Regulations through implementing industry best practices. We all have a duty of care to assess the hazards in the workplace and to implement systems and programs in order to eliminate or minimise the risk they present.

These documents prompt the review of many areas in fluid power systems that may present a risk and sets out guidelines of how they should be addressed using 'best industry practice'.

RYCO have a commitment to OH&S and the MDG's, and as such have developed products and strategies to assist our customers in understanding the requirements of the guideline. We can assist you to adopt the recommended practices outlined in MDG 41 and MDG 15.

### MDG 15

MDG 15 is a guideline for all mobile or transportable plant used at mines, and refers to MDG 41 for fluid power systems. It has further requirements in relation to the routing of hosing.

## MATCHED SYSTEM MDG 41 - CLAUSE 1.6.13

**Where the hose and fittings (insert/ferrule) are from the same manufacturer and are assembled and crimped using the method as specified by that manufacturer.**

### MATCHED SOLUTIONS

Today's hydraulic systems are required to withstand tremendous pressures. This means that the attachment of a fitting to the end of a hose becomes more critical. This may be a simple operation, but it is a complex engineering solution.

International Hose standards specify a set of materials and tolerances, such as internal and external dimensions and reinforcement types and patterns. The reality is that while these standards are adhered to by all manufacturers, the tolerances themselves are so broad that if the entire allowable tolerance was used in manufacturing, users would encounter a high failure rate due to hose and fitting tolerance mismatching. High quality hose manufacturers have to adopt their own tolerance limits which are often at least half of the allowed range.

This is where "Mixing and Matching" becomes an issue: Component manufacturer 'A' could produce parts on the lower limits of the tolerance, and manufacturer 'B' is on the upper end of the tolerance. If a fitting from 'B' was put on a hose from 'A' at the specified crimp diameter of 'B', there would be little chance of adequate fitting retention, which would most likely result in failure. Similarly if a fitting from 'A' was assembled to a hose from 'B' the likelihood is that the inner tube of the hose would be over-compressed or the hose reinforcement could be cut, again resulting in premature failure.

MDG 41 stipulates hose assemblies shall only be carried out using "Matched Hose and Fittings" (MDG 41 Clause 3.7.6.1k). MDG 41 defines a "Matched System" as "where the hose and fittings (insert/ferrule) are from the same manufacturer and are assembled and crimped using the method as specified by that manufacturer" (MDG 41 Clause 1.6.13).

Suppliers of manufactured hydraulic hose assemblies must be able to guarantee that the hose and fittings used are matched. RYCO products provide our customers with a matched system. Our design teams create and stringently test the hoses and fittings together to ensure optimum performance and reliability. All this is achieved using RYCO's assembly methods which are reliable and easy to follow.

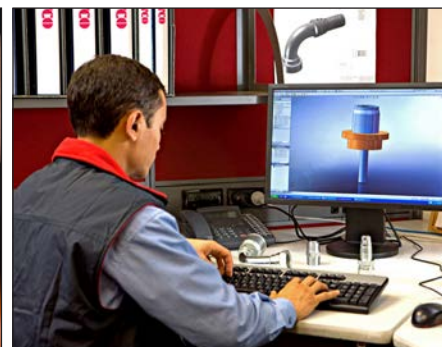

INTRODUCTION

HOSE

COUPLINGS

ADAPTORS

TECHNICAL

## HOSE ENDS MDG 41 - CLAUSE 3.7.6.2

Hose ends shall not be interchanged and shall be properly matched.  
**Note:** Only select hose fittings compatible for the hose application.



- RYCO branded
- Individual part number
- Batch numbered
- Matched to hose
- Series code grooves



## COMPETENCE MDG 41 CLAUSE - 3.7.6.6

Persons fabricating hose assemblies shall be competent and trained in the proper use of equipment, materials, assembly procedures and testing. People should be assessed in their competence for hose assembly and the assessment should be recorded.

## SAFETY SOLUTIONS

Our team of experienced engineering personnel can provide a engineering solution to suit your needs. Whether it's a simple question of product application, or the supply contract to multiple mine sites, we have the knowledge, experience and products to give you the most complete solution to your needs.

Experience is a very important quality in a supplier. The experience that RYCO has gained in many industries is a tangible asset, and one that keeps customer's coming back to us, because, like you, we've been out there working. The chances are that we've already supplied to someone who had exactly the same need for a solution as you, and that we've already helped someone else find that solution. "That's experience".

RYCO is aware of its responsibility to you the customer. We understand that the supply of our product does not finish with the goods being shipped.

Hydraulic hose assemblies can present a very real danger if misapplied. We understand this, and can provide you with the competence based training ensuring that you have the methods, products and knowledge to manufacture a matched hydraulic hose assembly each and every time.

## RESEARCH

RYCO is a specialist supplier of hydraulic hose and fittings to the mining industry; heavy-duty mining requires heavy-duty product. RYCO is constantly working together with the mining industry to research and develop new technologies and solutions to your specific hydraulic requirements. MDG 41 is just one of these solutions.



# INTRODUCTION

## ABOUT RYCO – INNOVATION

### INNOVATION

RYCO's commitment to Innovation and Continuous Improvement ensure that we can deliver tomorrow's solutions today. We believe that our global strength in Engineering, Innovation and product development provide our customers a high level of service and solutions unparalleled in the industry.

RYCO's Global Research and Development test facilities give our design teams the platform they require to continually improve our products to surpass the performance requirements as demanded by our customers and industry standards.

RYCO's product range is continually expanding and evolving, providing improved efficiency, higher working pressures and increased safety standards.

We design our product for tomorrow's requirements, today.

RYCO's Technology makes us a leader in our industry. Our policy of high investment in technology ensures that we not only maintain our position in the industry, but also continually improve and develop products that surpass industry standards.

We continually enhance our Hydraulic Hose Specifications as we introduce new technical developments.

RYCO's Coupling technology and higher performing ISOBARIC hose families make our matched assemblies a world leader in performance, efficiency and safety.

RYCO's extensive testing process of hydraulic hose, fittings and assemblies is crucial to deliver accredited and proven product quality.

**WE DESIGN OUR PRODUCT FOR TOMORROW'S REQUIREMENTS, TODAY.**



RYCO Dalian

TRAINING

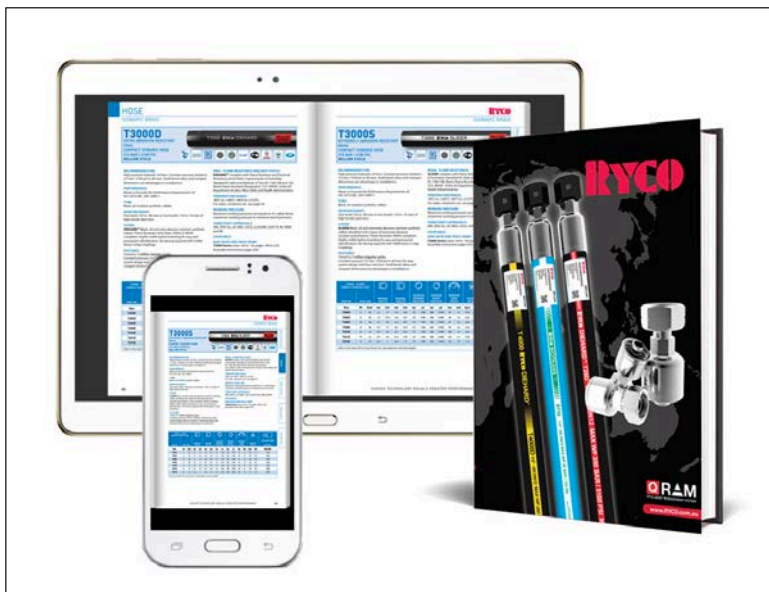

RYCO offers a broad range of modular training solutions to meet the needs of the hydraulic industry.

With safety a priority RYCO training equips you with the knowledge and confidence you need .

INTRODUCTION

HOSE

COUPLINGS

ADAPTORS

TECHNICAL

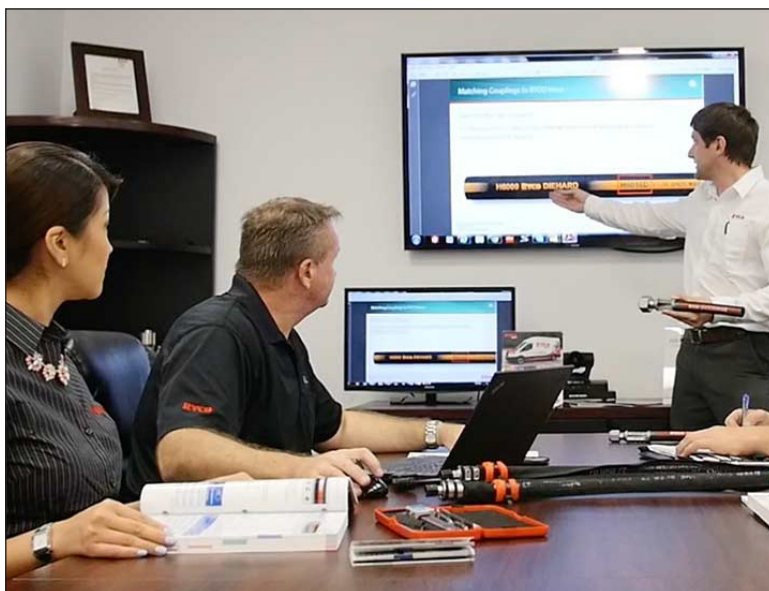

RYCO's commitment is to continually improve our services to you, our partners.

We understand that training is an essential part of your business. We strive to provide the best in the industry.



RYCO is a specialist supplier of hydraulic hose and fittings with over 70 years experience.

RYCO training equips you with the knowledge and the confidence you need, and the KNOW HOW to back it up.



# INTRODUCTION

## ABOUT RYCO – SERVICES AND SUPPORT

### GRAM - RYCO ASSET MANAGEMENT SYSTEM



**GRAM is RYCO's innovative asset management system for tracking and easily identifying assets in any geographical location. QRAM provides customers with:**

- ✓ Global asset tracking across desktop, tablet and mobile devices
- ✓ Improved customer retention through aftermarket sales and ease of supply
- ✓ 100% accuracy and speed to market
- ✓ Complete bill of materials and manufacturing processes
- ✓ Visibility of the assets, including test certificates, engineering drawings and installation images



#### **One Scan. Endless Possibilities**

GRAM can be securely accessed anywhere, anytime by using compatible mobile or desktop devices connected to the internet.

GRAM can record the position of your asset within a circuit of the machine. For example, you may place an asset in the 'Front Left Steering Circuit'.

An increase in your customers equipment utilisation can be achieved with QRAM's asset auditing and preventative maintenance features.



#### **Bringing Your Customer Back to You:**

- Customer Retention
- Scan to Sale
- Aftermarket Sales
- 24/7 Ordering Service
- Proactive Asset Auditing

## HALP® - HOSE ASSEMBLY LIFESPAN PREDICTOR

**Hose Assembly Lifespan Predictor** is part of the QRAM system, an online program that predicts the lifespan of hose assemblies for given conditions and environments.



**RYCO HALP®** aids in determining the optimum time to carry out preventative maintenance and replace hose assemblies before they fail.

By being proactive HALP® assists in risk management and helps to prevent fluid injection injuries.

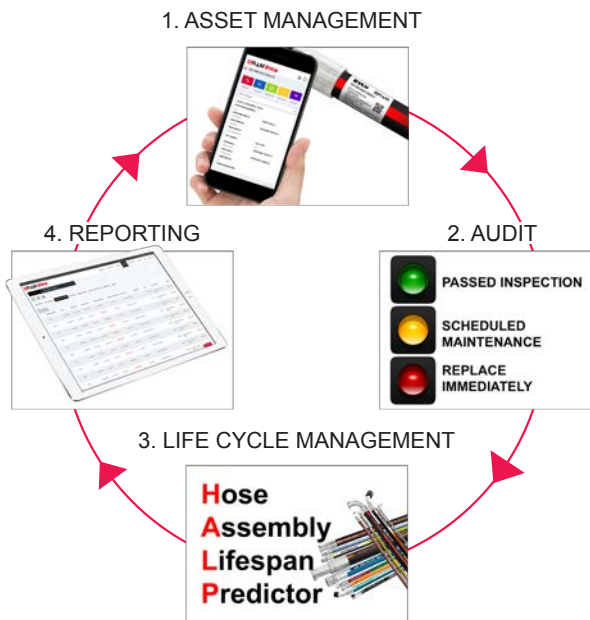

**RYCO HALP®** incorporates a database of hose assemblies, tracking their components and machine locations.

When coupled with predictive technology, HALP® keeps you on track with scheduled hose maintenance.



INTRODUCTION

HOSE

COUPLINGS

ADAPTORS

TECHNICAL



# RYCO 24•7



## RYCO 24•7

RYCO 24•7 operators are equipped with local knowledge and industry experience. All operators are trained with national accreditation providing you with confidence in the services of our technicians and products.

RYCO 24•7 mobiles are now servicing your local region, supported by quality RYCO product.



### RYCO 24•7 - MOBILE HOSE AND FITTING SERVICE

During 70 years of business, RYCO has increased its market coverage by establishing RYCO 24•7 Service Centres, Mobile Connector Specialists and Onsite Container Workshops in several countries around the world.

Today RYCO 24•7 has extensive coverage specialising in mobile hydraulic hose, fittings, service and replacement 24 hours a day, 7 days a week. RYCO 24•7 actively supports and services national contracts and Original Equipment Manufacturers (OEM) in industries covering mining, agriculture, marine, construction, defence and industrial markets.

With the continued support of RYCO Hydraulics, being a leading manufacturer of hydraulic hose and fittings we offer a network of RYCO 24•7 Service Centres, Mobile Connector Specialists and Onsite Container Workshops for the emergency break down, programmed maintenance, OEM support, installation and aftermarket business.

### RYCO 24•7 MISSION STATEMENT

Our Mission is to listen to our customers and deliver the highest quality and technologically superior fluid conveying connection products and solutions.

INTRODUCTION

HOSE

COUPLINGS

ADAPTORS

TECHNICAL



# INTRODUCTION

## ABOUT RYCO – SERVICES AND SUPPORT



Increase productivity and profitability

Extensive training & support

Ensures minimal downtime

Set-up to suit specific site requirements

Onsite container workshop and inventory storage

Ideal for remote locations, fully relocatable

## RYCO 24•7 SERVICES

RYCO 24•7 offers a comprehensive service for the hydraulic industry with emergency break down, programmed maintenance, Original Equipment Manufacturer support, installation and aftermarket business. Our professionally trained and dedicated teams are on call 24 hours a day, 7 days a week offering expert technical support for all types of hydraulic systems.

Whether it is mining, marine, agriculture, defence, construction, industrial or utilities the team at RYCO 24•7 will be on hand, anywhere, anytime, to offer you professional assistance.

RYCO 24•7 Service Centres, Mobile Connector Specialists and Onsite Container Workshops offer extensive multi-national contract and Original Equipment Manufacturer support through the development of hose assembly design, configuration, installation and aftersales service.

Quite often hose assembly plumbing can be an afterthought when designing complex hydraulic systems. With RYCO 24•7 support, our technical teams have the knowledge to assist with efficient and effective port to port solutions in the early stages of system design.

With comprehensive product and system knowledge, RYCO 24•7 technicians can be an integral partner in developing a marketing leading product including efficiency in system performance, warranty reduction and aftersales service.

Also, RYCO 24•7 has developed a new range of onsite hose assembly workshops and product storage containers. Ideal solution for remote mining locations, construction sites, offshore and large manufacturing sites.

## ONSITE HOSE CONTAINERS

As part of the ongoing focus on customer service, RYCO 24•7 has developed a new range of onsite hose assembly workshops and product storage containers. The RYCO 24•7 containers are an ideal solution for remote mining locations, construction sites, offshore and large manufacturing sites. See the RYCO 24•7 website for your nearest Service Centre or contact RYCO direct for assistance.

## HYDRAULIC HOSE AND COUPLING TOLERANCING

A common misconception is that **IF** a coupling matches to a hose that meets SAE or EN (DIN) specification THEN that coupling will match with **ALL** hydraulic hoses that meet that specification. Conversely, IF a hose that meets SAE or EN (DIN) specification matches to a coupling **THEN** that hose will match with **ALL** couplings made for hoses within that specification. **THIS IS SIMPLY NOT TRUE.**

As stated in SAE J517, the specification for Hydraulic Hose:

**"SAE J517 HOSE FROM ONE MANUFACTURER IS USUALLY NOT COMPATIBLE WITH SAE J516 CONNECTORS SUPPLIED BY ANOTHER MANUFACTURER. IT IS THE RESPONSIBILITY OF THE (HOSE ASSEMBLY) FABRICATOR TO CONSULT THE MANUFACTURER'S WRITTEN INSTRUCTIONS OR THE MANUFACTURERS DIRECTLY BEFORE INTERMIXING HOSE AND CONNECTORS FROM TWO MANUFACTURERS".**

There are various societies and organisations that develop specifications for Hydraulic Hose. The major ones are:

- SAE** The Society of Automotive Engineers
- EN** European Normes (based on the former DIN German standards)
- ISO** International Organization for Standardization
- AS** Australian Standards

These standards cover the performance specifications and dimensional tolerances of Hydraulic Hose.

SAE dimensional tolerances are the most widely used. EN, ISO and AS dimensional tolerances are similar to the corresponding SAE standard. Therefore, it is generally possible to meet the dimensional tolerances of these standards with a single series of hose. In the main, EN (DIN) standards have higher working pressures than their corresponding SAE standards.

Dimensional tolerances of these standards are quite broad. Hoses not manufactured to tight tolerance control may still meet these standards, but will perform poorly due to compression variations and will have assembly difficulties. This is not commonly understood. Hence, the common misconception stated above.

**RYCO** Hydraulics has its own **HYDRAULIC HOSE SPECIFICATION**. **RYCO** dimensional tolerances are much tighter than SAE or EN, and often have higher maximum working pressures.

Close tolerancing enables **RYCO** to provide higher performance Hydraulic Hose. **RYCO** Couplings are designed to match technically superior **RYCO** Hydraulic Hose. Superior technology gives **SAFER, STRONGER AND LONGER LASTING HOSE ASSEMBLIES**.

**DO NOT MIX/MATCH HOSE AND COUPLINGS FROM ONE MANUFACTURER WITH HOSE AND COUPLINGS FROM ANOTHER MANUFACTURER.**



**RYCO HOSE IS MATCHED TO RYCO COUPLINGS**

# INTRODUCTION

## RYCO EXPERIENCE

### RYCO SAFETY ZONE

The RYCO SAFETY ZONE provides an increased margin of operational safety when using RYCO matched hose and fittings.

Hose tolerance bands for Hose Bore, Reinforcement Diameter, Braid Wall, Cover Thickness and Concentricity of RYCO hoses are typically half the tolerance specified by SAE and EN/DIN standards.

All hoses and all fittings are not equal, "RYCO fittings are designed, matched and qualified for use with RYCO hose."

All RYCO hydraulic hose and fittings are designed and manufactured to meet and exceed relevant industry standards. RYCO produces hydraulic hose that is dimensionally consistent and when matched with RYCO fittings, results in increased safety and performance.

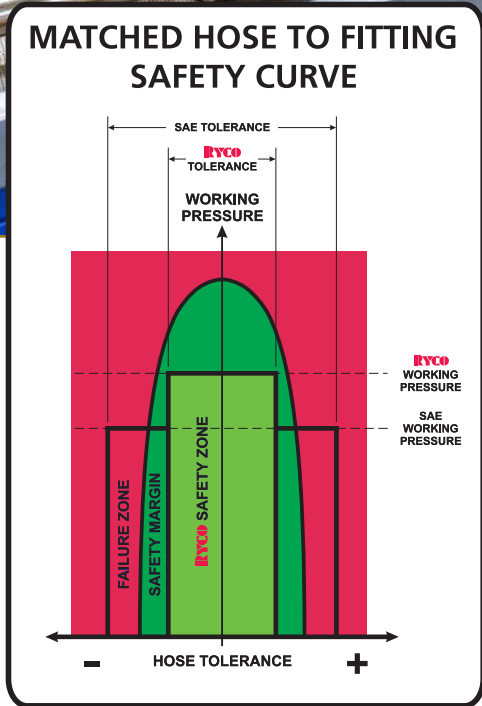
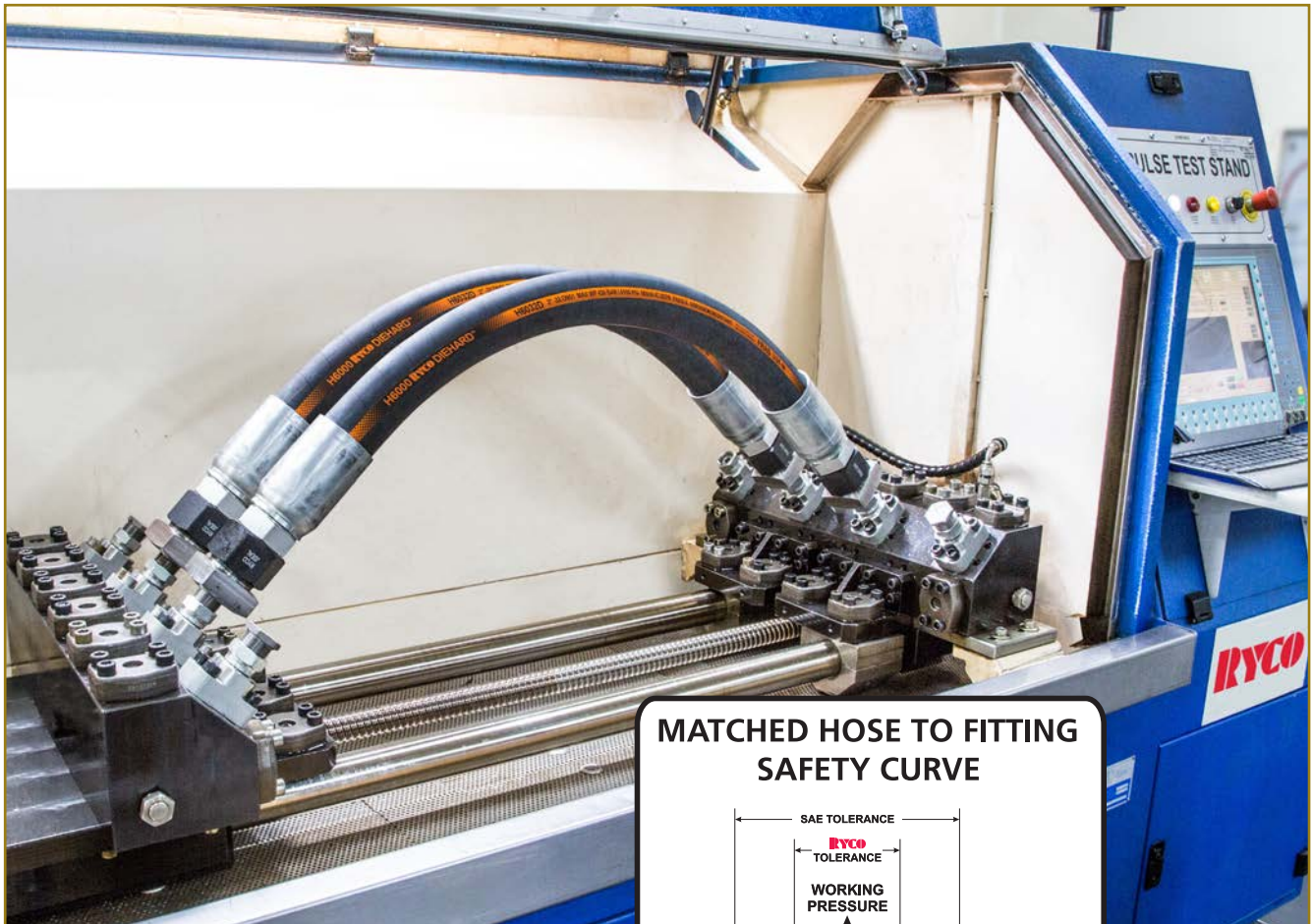

**SAFETY SAYS  
"DO NOT MIX 'N' MATCH OR ELSE PAY THE PRICE!"**



## IMPORTANT INFORMATION: HOSE COUPLING PART NUMBER CHANGES

RYCO's dedication to customer service is paramount. That's why we are constantly expanding our range of hose couplings to meet all of your application needs. In 2012, RYCO updated and improved the part numbering system, which was seamlessly integrated across the product range.

This new part numbering system entailed adding an extra numeric character to 2-digit end style (thread/connector termination) codes, and converting most alpha-numeric end styles to a 3-digit code. The exceptions to this rule are the following:

"N" will remain in the end style coding where "N" currently represents NPT or NPSM

"S" will replace current "SS" in the end style coding where "SS" currently represents Stainless Steel material

"B" will remain in the end style coding where "B" currently represents Brass material.

To maintain high levels of Customer Service, traceability and accurate product identification, for many years RYCO has been branding both ferrules and inserts of hose couplings. RYCO will continue to provide this level of detail on hose couplings (including ferrules and inserts) bearing the new part numbering format. There will be no change to the identification grooves that currently exist, except for those new hose coupling series' for which the basic markings/branding are represented on the graphics herein and in the RYCO Crimp Chart.

**The basic nomenclature for identifying New to Previous hose coupling series' is as follows:**

ONE-PIECE COUPLING SERIES	
NEW	PREVIOUS
Series	Series
T2000	T200
T4000	T400
T6000	-
T7000	T700
TP000	-
TG000	-
TT000	1100/RT00*
TW000	-

FIELD-ATTACHABLE AND PUSH-ON COUPLING SERIES			
NEW		PREVIOUS	
Coupling/ Ferrule	Insert	Coupling/ Ferrule	Insert
8000	-	800	-
33000	-	3300	-
K000	6000	K00	600
L000	6000	L00	600
M000	6000	400	600
P000	6000	-	-
V000	6000	V00	600

**It should be noted that the following remain identical for a coupling branded with the new part numbering convention and its equivalent part branded with the previous part numbering convention:**

- assembly parameters (crimp diameters, mark length and skive lengths)
- performance
- design
- scope of application.

**In addition to the hose coupling part numbering change, the following applies:**

- The part number change was effective as of the January 2013.
- Parts supplied under the new part number may reflect previous part number branding
- Both new and previous couplings series are matched to the same range of RYCO hoses as listed in current RYCO literature (unless otherwise stated), and should be assembled as per the current RYCO Crimp Chart
- Thread/Connector and Hose Dash Size numbering remains unchanged.

# INTRODUCTION

## DASH SIZE PART NUMBERING

One of the many, well recognised advantages of RYCO Hydraulics products is that virtually all parts are branded with the RYCO name and Part Number, making for easy identification and reducing the chance for errors.

The Part Number includes the Size of the Hose, or Thread or Connector ("Dash Size Part Numbering").

### ESSENTIALLY:

IMPERIAL DIMENSIONS are expressed as the number of SIXTEENTHS of an inch.

METRIC DIMENSIONS are expressed as the number of MILLIMETRES.

Further explanation is given on the following pages.

### FOR EXAMPLE:

1. **T26D** is T2D Series two wire braid non-skive hose:

-6 =  $6/16'' = 3/8''$  inside diameter.

2. **T2040-0812** is a T2040 JSEAL™ Coupling with:

Hose Size -08 =  $8/16'' = 1/2''$

Thread Size -12 =  $12/16'' = 3/4''$

3. **M75S-2208** is an M75S Adaptor with:

Thread A -22 = 22 mm Metric thread one end and

Thread B -08 =  $8/16'' = 1/2''$  BSPP thread other end.

4. **S27-0202**

S27 is BSPT Male Nipple Series

-0202 is size  $1/8''$  by  $1/8''$ .

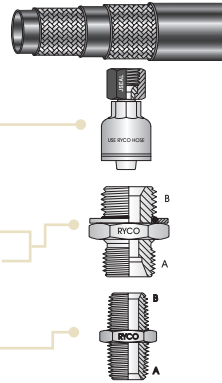

The size is clearly incorporated in the Part Number.

With a little familiarity, and by following the simple guidelines on the next pages, you will find that you can specify Part Numbers without needing to refer to the Product Technical Manual.

<b>NPT</b>	<b>T2090</b>
------------	--------------

60° SEAT

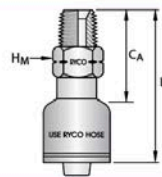

HOSE SIZE	THRD SIZE	DASH SIZE	MALE HEX	NPT MALE					
				HM-SPANNER	PART NO	CA	L		
DN	inch	inch	inch	mm	inch	mm	inch	mm	
5	3/16	1/8	-0302	1/2	<b>T2090-0302</b>	0.91	23	1.65	42
5	3/16	1/4	-0304	9/16	<b>T2090-0304</b>	1.14	29	1.93	49
6	1/4	1/8	-0402	1/2	<b>T2090-0402</b>	1.10	28	2.13	54
6	1/4	1/4	-0404	9/16	<b>T2090-0404</b>	1.26	32	2.24	57
6	1/4	3/8	-0406	3/4	<b>T2090-0406</b>	1.34	34	2.32	59

## HOSE COUPLINGS

Part No. **T2090-0406**

T2090 is the Group Designator for NPT Male T2000 Series One-Piece Crimp Couplings.

**T2090-0406** T2000 T2000 Series One-Piece Crimp Couplings

**T2090-0406** 090 NPT Male (End Style Termination)

**T2090-0406** 0406 is the Size Designator (Dash Size) (Hose Size then Thread Size)

**T2090-0406** 04 Hose Size  $4/16'' = 1/4''$

**T2090-0406** 06 Thread Size  $6/16'' = 3/8''$

<b>BSP/UNO</b>	<b>S95</b>
----------------	------------

STRAIGHT

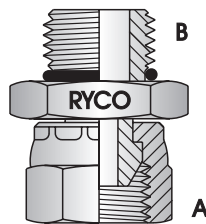

THREAD SIZE		DASH SIZE	BSPP FEMALE SWIVEL UN O RING MALE
A	B		
inch	inch		PART NO
1/8	7/16	-0207	
1/4	9/16	-0409	<b>S95-0409</b>

## ADAPTORS

Part No. **S95-0409**

S95 is the Group Designator for BSPP Female Swivel to UN O Ring Male

**S95-0409** BSPP Female Swivel to UN O Ring Male

**S95-0409** is the Dash Size (A end then B end)

**S95-0409** 4/16" Thread Size = 1/4"

**S95-0409** 9/16" Thread Size

RYCO's dedication to providing customer service across multiple markets is paramount. That's why we have expanded our range of hose couplings to meet all of your application needs. RYCO is now offering a range of metric nuts on selected sizes in BSP, JSEAL™ and JIC hose couplings.

The introduction of our metric part numbering system is easily read and identified in the product technical manual.

Below is an example of how to identify a JSEAL™ part number with a metric nut:

## COUPLINGS

### T2000 SERIES ONE-PIECE CRIMP COUPLINGS

JSEAL™ / JIC	T2040 - T2041
--------------	---------------

CONVEX SEAT



HOSE SIZE	THRD SIZE	TUBE SIZE	DASH SIZE	BACK UP AF	FEMALE HEX		JSEAL™ / JIC FEMALE					
					Af-SPANNER	Hf-SPANNER	PART NO		Ca		L	
DN	inch	inch	inch	inch	inch	mm	inch	mm	inch	mm	inch	mm
6	1/4	7/16	1/4	-0407	1/2	9/16	T2040-0407		0.75	19	1.73	44
					12	14	T2041-0407					
6	1/4	1/2	5/16	-0408	1/2	5/8	16	T2040-0408	0.83	21	1.85	47
6	1/4	9/16	3/8	-0409	1/2	11/16	T2040-0409		0.87	22	1.89	48
					12	3/4	19	T2041-0409				

HOSE SIZE	THRD SIZE	TUBE SIZE	DASH SIZE	BACK UP AF	FEMALE HEX		JSEAL™ / JIC FEMALE					
					Af-SPANNER	Hf-SPANNER	PART NO		Ca		L	
DN	inch	inch	inch	inch	inch	mm	inch	mm	inch	mm	inch	mm
6	1/4	7/16	1/4	-0407	1/2	9/16	T2040-0407		0.75	19	1.73	44
						12	14	T2041-0407				

### IMPERIAL VERSION

1/2	9/16	T2040-0407
-----	------	------------

Back up Nut - Across Flats (AF)      1/2 inch  
Hex Female Nut - (HF)                      9/16 inch

### METRIC VERSION

12	14	T2041-0407
----	----	------------

Back up Nut - Across Flats (AF)      12 mm  
Hex Female Nut - (HF)                      14 mm

### IMPORTANT TO REMEMBER:

IMPERIAL DIMENSIONS are expressed as the number of SIXTEENTHS of an inch.  
METRIC DIMENSIONS are expressed as the number of MILLIMETRES.

IMPERIAL and METRIC stock availability may vary due to country and industry preferences. Please contact your local RYCO representative for availability.



# INTRODUCTION

## DASH SIZE PART NUMBERING

### RYCO “DASH SIZE” DEFINITIONS

The “Dash Size” of a Hose, Coupling, Thread or Connector is:

#### 1. FOR HOSE

The number of SIXTEENTHS of an inch in the Inside Diameter.

#### 2. FOR THREADS OR CONNECTORS WITH IMPERIAL DIMENSIONS

a) JSEAL™, JIC, SAE Threads, ORFS, UNO: the number of SIXTEENTHS of an inch in the size of the Male Thread.

b) BSP, NPT, SAE Flange, RYCO WEO, HAMMER UNION: the number of SIXTEENTHS of an inch in the Nominal Size of the Connector.

c) Tubing and Tube Bite: the number of SIXTEENTHS of an inch in the Outside Diameter of the Tube.

#### 3. FOR THREADS OR CONNECTORS WITH METRIC DIMENSIONS

a) the number of MILLIMETRES in the OD of the Male Thread (pitch of thread is sometimes included).

b) Tubing and Tube Bite: the number of MILLIMETRES in the Outside Diameter of the Tube.

#### 4. FOR RYCOLOK & SUPERLOK COUPLINGS

The nominal size of the Coupling in MILLIMETRES.

#### 5. FOR QUICK RELEASE COUPLINGS

The nominal size of the Coupling in SIXTEENTHS of an inch.

#### 6. FOR HOSE PROTECTION

RWA, RH, RCS                      Inside Diameter in MILLIMETRES.

FS1072                                Inside Diameter in SIXTEENTHS of an inch.

RSG/RSGY/RSGF                    Outside Diameter in MILLIMETRES.

#### 7. FOR HYDRAULIC FILTERS EXCEPTION TO RULE

Hydraulic Filters are dash sized for the number of EIGHTHS of an inch in the port size of the Filter.

## RULES FOR “DASH SIZE” PART NUMBERING

### HYDRAULIC HOSE

Part Number comprises the Hose Series Number followed by the Dash Size.

Note: For Dash Sizes -02, -03, -04, -05, -06 and -08 the “0” is not included in the Part Number except for Spiral Hose and Isobaric Hose.

Hose Series Numbers are shown in Hose Pictorial Index on pages 36 to 44

Dash Sizes are shown in the Quick Reference Chart on page 34.

#### EXAMPLES

-16 size SRF Series Hose is SRF16

-12 size M2 Series Hose is M212

-10 size RTH1 Series Hose is RTH110

-08 size R4SPD Series (Spiral) Hose is R4SP08

#### NOTE

If there are letters at the end of the Hose Series Number, Dash Size comes before letters.

T3000D, T3000S, T3600C, T3600D, T3600S, T4000D, T4000S, T5000D, T5000S, T6000D, T6000S, H3000D, H3000S, H4000D, H4000S, H5000D, H5000S, H6000D, H6000S, C6000D, C6000S, DF1D, DF2D, DK1D, DK1E, DK1S, DK2D, DK2E, DK2S, EC1, EC2, E1, E2, D2B, H12D, H12S, M2G, PL1D, R4SHD, R4SPD, TP7N, TP7T, TP7TN, TP8N, TP8T, TP8TN, T1D, T1F, T1S, T2D, T2S, T2C, TJ2D, TXA2D, RQP1, RQP2, RQP5, RQP6, T5 and BT1

#### EXAMPLES

-32 size H6000D Series Hose is H6032D

-20 size H12D Series Hose is H1220D

-06 size DF2D Series Hose is DF26D

-06 size TP7TN Series hose is TP76TN

## HOSE COUPLINGS

Part Numbers comprise Coupling Series and End Style Number followed by the Dash Size of the Hose and the Dash Size of either the Thread or Connector Size. Coupling Series and End Style Numbers are described at start of Hose Coupling Section. (See page 167 and pages 181 to 308)

### EXAMPLES

#### T2000 ONE-PIECE CRIMP COUPLING

3/4" hose x 1.1/16" JSEAL™ Female

**Order Part No. T2040-1217**

**T2040-1217** T200 Series Coupling  
**T2040-1217** JSEAL™ Female End Style

**T2040-1217** is the Size Designator (Dash Size),  
 (Hose Size then Thread Size)

**T2040-1217** -12 = 12/16" = 3/4" hose  
**T2040-1217** -17 = 17/16" = 1.1/16" thread

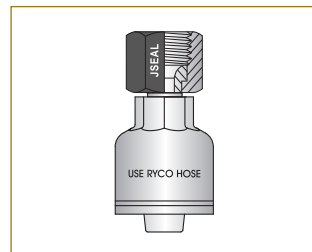

#### FIELD ATTACHABLE INSERT

1/2" BSPT Male for 3/8" hose.

**Order Part No. 6010-0608**

**6010-0608** 600 Series Insert  
**6010-0608** BSPT Male End Style

**6010-0608** is the Size Designator (Dash Size),  
 (Hose Size then Thread Size)

**6010-0608** -06 = 6/16" = 3/8" hose  
**6010-0608** -08 = 8/16" = 1/2" thread

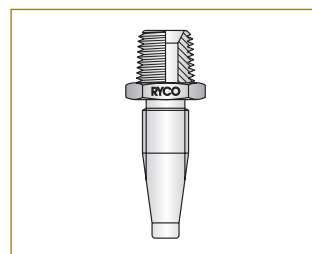

## ADAPTORS

Part Numbers comprise of Group Designator followed by Dash Size. (Group Designators are shown in Adaptors Pictorial Index pages <?> to <?>).

### EXAMPLES

#### NPT MALE TO NPT MALE NIPPLE (STRAIGHT)

3/4" NPT Male x 1/4" NPT Male Nipple

**Order Part No. S27N-1208**

**S27N-1208** Group Designator for NPT Male Nipple

**S27N-1208** is the Dash Size (A end then B end)

**S27N-1208** -12 = 12/16" = 3/4" thread (A)

**S27N-1208** -08 = 8/16" = 1/2" thread (B)

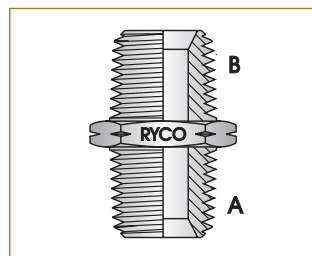

#### JIC MALE TO UNO RING MALE 90 ELBOW

3/4" JIC Male x 1.5/16" UNO Ring Male 90 Elbow

**Order Part No. S91-1221**

**S91-1221** Group Designator for NPT Male Nipple

**S91-1221** is the Dash Size (A end then B end)

**S91-1221** -12 = 12/16" = 3/4" thread (JIC) (A)

**S91-1221** -21 = 21/16" = 1.5/16" thread (UNO) (B)

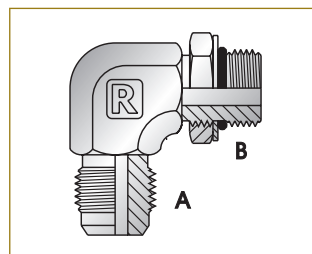

There are supplementary rules which determine the listing order for multi-ended adaptors. These rules are shown in detail on pages 30 to 31

See RYCO Product Technical Manual for Important Note regarding Thread Dash Sizes/Tube Dash Sizes.

# INTRODUCTION

## DASH SIZE PART NUMBERING

### QUICK REFERENCE CHART OF DASH SIZE EQUIVALENTS

**EXAMPLE:** Find Dash Size for 1.5/16" JIC thread. Read down JIC & UNO column until 1.5/16" is reached.  
Read off Dash Size in far left column (-21).

DASH SIZE	* inch	BSP inch-TPI	NPT inch-TPI	JSEAL, JIC & UNO inch-TPI	SAE FLARE inch-TPI	ORFS inch-TPI
-02	1/8	1/8 - 28	1/8 - 27			
-03	3/16					
-04	1/4	1/4 - 19	1/4 - 18			
-05	5/16			5/16 - 24	5/16 - 24	
-06	3/8	3/8 - 19	3/8 - 18	3/8 - 24	3/8 - 24	
-07	7/16			7/16 - 20	7/16 - 20	
-08	1/2	1/2 - 14	1/2 - 14	1/2 - 20	1/2 - 20	
-09	9/16			9/16 - 18		9/16 - 18
-10	5/8	5/8 - 14			5/8 - 18	
-11	11/16					11/16 - 16
-12	3/4	3/4 - 14	3/4 - 14	3/4 - 16	3/4 - 16	
-13	13/16					13/16 - 16
-14	7/8			7/8 - 14	7/8 - 14	
-15	15/16					
-16	1	1 - 11	1 - 11.1/2			1 - 14
-17	1.1/16			1.1/16 - 12	1.1/16 - 14	
-18	1.1/8					
-19	1.3/16					1.3/16 - 12
-20	1.1/4	1.1/4 - 11	1.1/4 - 11.1/2			
-21	1.5/16			1.5/16 - 12		
-22	1.3/8					
-23	1.7/16					1.7/16 - 12
-24	1.1/2	1.1/2 - 11	1.1/2 - 11.1/2			
-25	1.9/16					
-26	1.5/8			1.5/8 - 12		
-27	1.11/16					1.11/16 - 12
-28	1.3/4					
-29	1.13/16					
-30	1.7/8			1.7/8 - 12		
-31	1.15/16					
-32	2	2 - 11	2 - 11.1/2			2 - 12
-33	2.1/16					
-36	2.1/4					
-40	2.1/2	2.1/2 - 11	2.1/2 - 8	2.1/2 - 12		
-42	2.5/8					
-48	3	3 - 11		3 - 8		
-50	3.1/8					
-52	3.1/4					
-60	3.3/4					
-63	3.15/16					
-75	4.11/16					

DASH SIZE	** mm	METRIC mm x Pitch
-02	2	
-03	3	
-04	4	
-05	5	
-06	6	
-07	7	
-08	8	
-09	9	
-10	10	
-11	11	
-12	12	
-13	13	
-14	14	14 x 1,5 (-1415)
-15	15	
-16	16	16 x 1,5 (-1615)
-17	17	
-18	18	18 x 1,5 (-1815)
-19	19	
-20	20	20 x 1,5 (-2015)
-21	21	
-22	22	22 x 1,5 (-2215)
-23	23	
-24	24	24 x 1,5 (-2415)
-25	25	
-26	26	26 x 1,5 (-2615)
-27	27	
-28	28	
-29	29	
-30	30	30 x 1,5 (-3015) 30 x 2,0 (-3020)
-31	31	
-32	32	
-33	33	33 x 1,5 (-3315)
-36	36	36 x 1,5 (-3615) 36 x 2,0 (-3620)
-40	40	
-42	42	42 x 1,5 (-4215) 42 x 2,0 (-4220)
-48	48	
-50	50	50 x 2,0 (-5020)
-52	52	52 x 2,0 (-5220)
-60	60	60 x 2,0 (-6020)
-63	63	
-75	75	

**\*INCH COLUMN IS USED FOR:**

- Hose ID.
- Imperial Tube OD.
- FS1072 FIRE SLEEVE ID.
- Nominal size of SAE FLANGE.
- Nominal size of Quick Release Coupling.

**\*\*MM COLUMN IS USED FOR:**

- Metric Tube OD.
- Nominal size of RYCOLOK and SUPERLOK Couplings.



# ■ HYDRAULIC HOSE

**RYCO XTREME SRX24** 1.1/2" -24 DN38 MAX WP 1

**RYCO SURVIVOR RQP28** 1/2" -08 DN12 MAX WP 30

**T4000 RYCO SLIDER™** **T4006S** 3/8" -06 DN10 MAX WP 280 BAR

**H6000 RYCO DIEHARD™** **H6032D** 2" -3

**RYCO DRILLER**

**RYCO SHOCKWAVE** **SW16008** 1/2" -08 DN12 MAX WP

**RYCO ISOLATOR TWIN** TP86TN 3/8 -06 DN10 MAX WP 280 BAR

**RYCO BIOTRANS** **BT112** 3/4" -12 DN19 MAX WP 50 BAR / 725 PSI MEETS OR EXCEEDS MSHA/IC 22715, SAE J1942 **MSHA** **HF**

**T3000 RYCO DIEHARD™** **T3008D** 1/2" -08 D

**H6000 RYCO SLIDER™** **H6016S** 1" -16 DN25 MAX WP 420 BAR / 610

**H5000 RYCO DIEHARD™** **H5020D** 1-1/4" -20

**T4000 RYCO SLIDER™** **T4006S** 3/8" -06 DN10 MAX WP 280 BAR / 4100 PSI **MSHA** **ABRASION RESISTANT** MEETS OR EXCEEDS SAE J109R12 EN10607

**RYCO DIEHARD™ T28D** 1/2" -08 DN12 MAX WP 350 BAR / 5100 P

**RYCO**

# HOSE

## PICTORIAL INDEX

HOSE SERIES		INSIDE DIAMETER	RECOMMENDED	CONSTRUCTION	PERFORMANCE SPECIFICATIONS MET OR EXCEEDED	COUPLING SERIES
<b>ISOBARIC BRAID</b>						
62	<b>T3000D</b> DIEHARD™		-04 to -16 1/4" to 1"	High pressure hydraulic oil lines.	Oil resistant synthetic rubber tube. One or two braids of high tensile steel wire reinforcement. Oil and extra abrasion resistant synthetic rubber cover.	ISO 18752-BC SAE 100R17 T2000
63	<b>T3000S</b> SLIDER		-04 to -16 1/4" to 1"	High pressure hydraulic oil lines.	Oil resistant synthetic rubber tube. One or two braids of high tensile steel wire reinforcement. Synthetic rubber cover sheathed with a layer of extremely abrasion resistant polyethylene cover.	ISO 18752-BC SAE 100R17 T2000
64	<b>T3600C</b> ICEBREAKER		-04 to -16 1/4" to 1"	High pressure hydraulic oil lines in applications where low temperature environmental conditions exist.	Oil resistant synthetic rubber tube. One braid of high tensile steel wire reinforcement. Oil and extra abrasion resistant synthetic rubber cover.	ISO 18752-BC T2000
65	<b>T3600D</b> DIEHARD™		-04 to -16 1/4" to 1"	High pressure hydraulic oil lines.	Oil resistant synthetic rubber tube. One or two braids of high tensile steel wire reinforcement. Oil and extra abrasion resistant synthetic rubber cover.	ISO 18752-BC T2000
66	<b>T3600S</b> SLIDER		-04 to -16 1/4" to 1"	High pressure hydraulic oil lines.	Oil resistant synthetic rubber. One or two braids of high tensile steel wire reinforcement. Oil and abrasion resistant synthetic rubber sheathed with a layer of extremely abrasion resistant polyethylene cover.	ISO 18752-BC T2000
67	<b>T4000D</b> DIEHARD™		-04 to -12 1/4" to 3/4"	High pressure hydraulic oil lines.	Oil resistant synthetic rubber tube. One or two braids of high tensile steel wire reinforcement. Oil and extra abrasion resistant synthetic rubber cover.	ISO 18752-BC SAE 100R19 T2000
68	<b>T4000S</b> SLIDER		-04 to -12 1/4" to 3/4"	High pressure hydraulic oil lines.	Oil resistant synthetic rubber tube. One or two braids of high tensile steel wire reinforcement. Synthetic rubber cover sheathed with a layer of extremely abrasion resistant polyethylene.	ISO 18752-BC SAE 100R19 T2000
69	<b>T5000D</b> DIEHARD™		-04 to -08 1/4" to 1/2"	Very high pressure hydraulic oil lines.	Oil resistant synthetic rubber tube. Two braids of high tensile steel wire reinforcement. Oil and extra abrasion resistant synthetic rubber cover.	ISO 18752-BC T2000
70	<b>T5000S</b> SLIDER		-04 to -08 1/4" to 1/2"	Very high pressure hydraulic oil lines.	Oil resistant synthetic rubber tube. Two braids of high tensile steel wire reinforcement. Synthetic rubber cover sheathed with a layer of extremely abrasion resistant polyethylene.	ISO 18752-BC T2000
71	<b>T6000D</b> DIEHARD™		-04 to -06 1/4" to 3/8"	Extremely high pressure hydraulic oil lines.	Oil resistant synthetic rubber tube. Two braids of high tensile steel wire reinforcement. Oil and extra abrasion resistant synthetic rubber cover.	ISO 18752-BC T2000
72	<b>T6000S</b> SLIDER		-04 to -06 1/4" to 3/8"	Extremely high pressure hydraulic oil lines.	Oil resistant synthetic rubber tube. Two braids of high tensile steel wire reinforcement. Synthetic rubber cover sheathed with a layer of extremely abrasion resistant polyethylene.	ISO 18752-BC T2000
<b>ISOBARIC SPIRAL</b>						
73	<b>H3000D</b> DIEHARD™		-20 to -32 1.1/4" to 2"	High pressure hydraulic oil lines.	Oil resistant synthetic rubber tube. Four alternating layers of spiralled high tensile steel wire reinforcement. Oil and extra abrasion resistant synthetic rubber cover.	EN 856 Type R12 EN 856 Type 45P ISO 18752-DC SAE 100R12 T7000
74	<b>H3000S</b> SLIDER		-20 to -32 1.1/4" to 2"	High pressure hydraulic oil lines.	Oil resistant synthetic rubber tube. Four alternating layers of spiralled high tensile steel wire reinforcement. Synthetic rubber cover sheathed with a layer of extremely abrasion resistant polyethylene.	EN 856 Type R12 EN 856 Type 45P ISO 18752-DC SAE 100R12 T7000

HOSE SERIES		INSIDE DIAMETER	RECOMMENDED	CONSTRUCTION	PERFORMANCE SPECIFICATIONS MET OR EXCEEDED	COUPLING SERIES
<b>ISOBARIC SPIRAL (CONT)</b>						
75	<b>H4000D</b> DIEHARD™		<b>-06 to -32</b> 3/8" to 2"	High pressure hydraulic oil lines.	Oil resistant synthetic rubber tube. Four or six alternating layers of spiralled high tensile steel wire reinforcement. Oil and extra abrasion resistant synthetic rubber cover.	EN 856 Type R12 EN 856 Type 45P (size DN25, -16) ISO 18752-DC SAE 100R12 T7000
76	<b>H4000S</b> SLIDER		<b>-06 to -32</b> 3/8" to 2"	High pressure hydraulic oil lines.	Oil resistant synthetic rubber tube. Four or six alternating layers of spiralled high tensile steel wire reinforcement. Synthetic rubber cover sheathed with a layer of extremely abrasion resistant polyethylene.	EN 856 Type R12 EN 856 Type 45P (size DN25, -16) ISO 18752-DC SAE 100R12 T7000
77	<b>H5000C</b> ICEBREAKER		<b>-12 to -20</b> 3/4" to 1 1/4"	Very high pressure hydraulic oil lines in applications where low temperature environmental conditions exist.	Very high pressure hydraulic oil lines in applications where low temperature environmental conditions exist. Small bend radius is an advantage in installations.	EN 856 Type R13 ISO 18752-CC SAE100R13 T7000
78	<b>H5000D</b> DIEHARD™		<b>-06 to -32</b> 3/8" to 2"	Very high pressure hydraulic oil lines.	Oil resistant synthetic rubber tube. Four or six alternating layers of spiralled high tensile steel wire reinforcement. Oil and extra abrasion resistant synthetic rubber cover.	EN 856 Type R13 ISO 18752-CC SAE100R13 T6000 T7000
79	<b>H5000S</b> SLIDER		<b>-06 to -32</b> 3/8" to 2"	Very high pressure hydraulic oil lines.	Oil resistant synthetic rubber tube. Four or six alternating layers of spiralled high tensile steel wire reinforcement. Synthetic rubber cover sheathed with a layer of extremely abrasion resistant polyethylene.	EN 856 Type R13 ISO 18752-CC SAE 100R13 T6000 T7000
80	<b>H6000D</b> DIEHARD™		<b>-06 to -32</b> 3/8" to 2"	Extremely high pressure hydraulic oil lines.	Oil resistant synthetic rubber tube. Four, six or eight alternating layers of spiralled high tensile steel wire reinforcement. Oil and extra abrasion resistant synthetic rubber cover.	EN 856 Type R15 ISO 18752-CC SAE 100R15 T6000 T7000
81	<b>H6000S</b> SLIDER		<b>-06 to -32</b> 3/8" to 2"	Extremely high pressure hydraulic oil lines.	Oil resistant synthetic rubber tube. Four, six or eight alternating layers of spiralled high tensile steel wire reinforcement. Synthetic rubber cover sheathed with a layer of extremely abrasion resistant polyethylene.	ISO 3862 Type R15 ISO 18752-CC SAE 100R15 T6000 T7000
82	<b>C6000D</b> DIEHARD™		<b>-12 to -16</b> 3/4" to 1"	Ultra flexible, extremely high pressure hydraulic oil lines.	Oil resistant synthetic rubber tube. Four alternating layers of spiralled high tensile steel wire reinforcement. Oil and extra abrasion resistant synthetic rubber cover.	ISO 18752-CC SAE100R15 T7000
83	<b>C6000S</b> SLIDER		<b>-12 to -16</b> 3/4" to 1"	Ultra flexible, extremely high pressure hydraulic oil lines.	Synthetic rubber cover sheathed with a layer of extremely abrasion resistant polyethylene. Oil and extra abrasion resistant synthetic rubber cover.	ISO 18752-CC SAE100R15 T7000
<b>BRAID</b>						
84	<b>DF1D</b> DIEHARD™		<b>-04 to -16</b> 1/4 to 1"	High pressure hydraulic oil lines.	Oil resistant synthetic rubber tube. One braid of high tensile steel wire reinforcement. Oil and extra abrasion resistant synthetic rubber cover.	EN 857 Type 15C ISO 11237 Type 15C T2000
85	<b>DF2D</b> DIEHARD™		<b>-04 to -20</b> 1/4 to 1.1/4"	High pressure hydraulic oil lines.	Oil resistant synthetic rubber tube. Two braids of high tensile steel wire reinforcement. Oil and extra abrasion resistant synthetic rubber cover.	EN 857 Type 25C ISO 11237 Type 25C SAE 100R16 T2000
86	<b>DK1D</b> DIEHARD™		<b>-04 to -20</b> 1/4 to 1.1/4"	Extra abrasion resistant high pressure hydraulic oil lines.	Oil resistant synthetic rubber tube. One braid of high tensile steel wire reinforcement. Oil and extra abrasion resistant synthetic rubber cover.	EN 857 Type 15C ISO 11237 Type 15C T2000
87	<b>DK1E</b> ENERGY		<b>-04 to -16</b> 1/4" to 1"	High pressure hydraulic oil lines.	Oil resistant synthetic rubber tube. One braid of high tensile steel wire reinforcement. Oil resistant synthetic rubber cover.	EN 857 Type 15C ISO 11237 Type 15C T2000

INTRODUCTION

HOSE

COUPLINGS











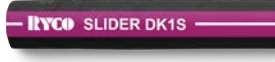

ADAPTORS







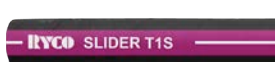

TECHNICAL

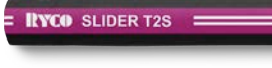
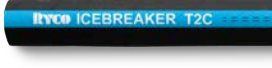
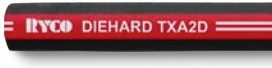

# HOSE



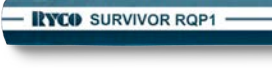
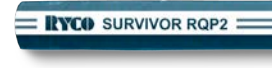

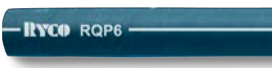







## PICTORIAL INDEX

HOSE SERIES		INSIDE DIAMETER	RECOMMENDED	CONSTRUCTION	PERFORMANCE SPECIFICATIONS MET OR EXCEEDED	COUPLING SERIES
<b>BRAID (CONT)</b>						
88	<b>DK1S</b> SLIDER		-04 to -20 1/4 to 1.1/4"	Extra abrasion resistant high pressure hydraulic oil lines.	Synthetic rubber cover sheathed with a layer of extremely abrasion resistant polyethylene. Oil and extra abrasion resistant synthetic rubber cover.	EN 857 Type 15C ISO 11237 Type 15C T2000
89	<b>DK2D</b> DIEHARD™		-04 to -20 1/4 to 1.1/4"	Extra abrasion resistant high pressure hydraulic oil lines.	Oil resistant synthetic rubber tube. Two braids of high tensile steel wire reinforcement. Oil and extra abrasion resistant synthetic rubber cover.	EN 857 Type 25C ISO 6805 Type 1 & Type 2 ISO 6805 Type 4 T2000
90	<b>DK2E</b> ENERGY		-04 to -16 1/4" to 1"	High pressure hydraulic oil lines.	Oil resistant synthetic rubber tube. Two braids of high tensile steel wire reinforcement. Oil resistant synthetic rubber cover.	EN 857 Type 25C ISO 6805 Type 1 & Type 2 ISO 6805 Type 4 T2000
91	<b>DK2S</b> SLIDER		-04 to -16 1/4" to 1"	High pressure hydraulic oil lines.	Synthetic rubber cover sheathed with a layer of extremely abrasion resistant polyethylene. Oil and extra abrasion resistant synthetic rubber cover.	EN 857 Type 25C ISO 6805 Type 1 & Type 2 ISO 6805 Type 4 T2000
93	<b>EC1</b> ENERGY		-04 to -16 1/4" to 1"	High pressure hydraulic oil lines. Compact outside diameter and smaller bend radius.	Oil resistant synthetic rubber tube. One braid of high tensile steel wire reinforcement. Oil resistant synthetic rubber cover.	EN 857 Type 15C ISO 11237 Type 15C T2000
94	<b>EC2</b> ENERGY		-04 to -16 1/4" to 1"	High pressure hydraulic oil lines. Compact outside diameter and smaller bend radius.	Oil resistant synthetic rubber tube. Two braids of high tensile steel wire reinforcement. Oil resistant synthetic rubber cover.	EN 857 Type 25C ISO 11237 Type 25C SAE 100R16 T2000
95	<b>ECP1</b> ENERGY		-03 to -08 3/16" to 1/2"	High pressure hydraulic oil pilot lines. Compact outside diameter and smaller bend radius.	Oil resistant synthetic rubber tube. One braid of high tensile steel wire reinforcement. Oil resistant synthetic rubber cover.	T2000
96	<b>E1</b> ENERGY		-04 to -16 1/4" to 1"	High pressure hydraulic oil lines.	Oil resistant synthetic rubber tube. One braid of high tensile steel wire reinforcement. Oil resistant synthetic rubber cover.	AS 3791 100R1AT DIN 20022-15N EN 853 Type 15N ISO 1436 Types R1AT & 15N SAE 100R1AT T2000 6000 (K000)
97	<b>E2</b> ENERGY		-04 to -16 1/4" to 1"	High pressure hydraulic oil lines.	Oil resistant synthetic rubber tube. Two braids of high tensile steel wire reinforcement. Oil resistant synthetic rubber cover.	AS 3791 100R2AT DIN 20022 - 25N EN 853 Type 25N ISO 1436 Types R2AT & 25N SAE 100R2AT T2000 T7000 6000 (L000)
98	<b>T1D</b> DIEHARD™		-03 to -32 3/16" to 2"	High pressure hydraulic oil lines.	Oil resistant synthetic rubber tube. One braid of high tensile steel wire reinforcement. Oil and extra abrasion resistant synthetic rubber cover.	AS 3791 100R1AT DIN 20022-15N EN 853 Type 15N ISO 1436 Types R1AT & 15N SAE 100R1AT T2000 6000 (K000)
99	<b>T1S</b> SLIDER		-03 to -32 3/16" to 2"	High pressure hydraulic oil lines.	Oil resistant synthetic rubber tube. One braid of high tensile steel wire reinforcement. Synthetic rubber cover sheathed with a layer of extremely abrasion resistant polyethylene.	AS 3791 100R1AT DIN 20022-15N EN 853 Type 15N ISO 1436 Types R1AT & 15N SAE 100R1AT T2000
100	<b>T1F</b> FIRE SUPPRESSION		-03 to -16 3/16" to 1"	Fire Suppression Systems of off-road vehicles, mining equipment, stationary engines, etc.	Oil resistant synthetic rubber tube. One braid of high tensile steel wire reinforcement. Red, heat resistant, abrasion resistant and oil resistant rubber cover.	AS 3791 100R1AT DIN 20022-15N EN 853 Type 15N ISO 1436 Types R1AT & 15N SAE 100R1AT T2000 6000 (K000)
101	<b>T2D</b> DIEHARD™		-04 to -48 1/4" to 3"	High pressure hydraulic oil lines.	Oil resistant synthetic rubber tube. Two braids of high tensile steel wire reinforcement. Oil and extra abrasion resistant synthetic rubber cover.	AS 3791 100R2AT DIN 20022 - 25N EN 853 Type 25N ISO 1436 Types R2AT & 25N SAE 100R2AT T2000 T7000 6000 (L000)

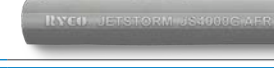

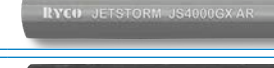
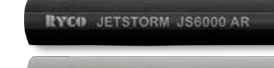
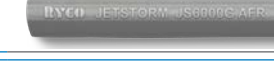





HOSE SERIES		INSIDE DIAMETER	RECOMMENDED	CONSTRUCTION	PERFORMANCE SPECIFICATIONS MET OR EXCEEDED	COUPLING SERIES
<b>BRAID (CONT)</b>						
102	<b>T2S</b> SLIDER		<b>-04 to -32</b> 1/4" to 2"	High pressure hydraulic oil lines.	Oil resistant synthetic rubber tube. Two braids of high tensile steel wire reinforcement. Synthetic rubber cover sheathed with a layer of extremely abrasion resistant polyethylene.	AS 3791 100R2AT DIN 20022-2SN EN 853 Type 2SN ISO 1436 Types R2AT & 2SN SAE 100R2AT T2000 T7000
103	<b>T2C</b> ICEBREAKER		<b>-04 to -32</b> 1/4" to 2"	High pressure hydraulic oil lines in applications where low temperature environmental conditions exist.	Specially formulated oil resistant synthetic rubber tube. Two braids of high tensile steel wire reinforcement. Oil resistant and abrasion resistant synthetic rubber cover.	AS 3791 100R2AT DIN 20022-2SN EN 853 Type 2SN ISO 1436 Types R2AT & 2SN SAE 100R2AT T2000
104	<b>TXA2D</b> DIEHARD™		<b>-08 to -16</b> 1/2" to 1"	Extra high pressure hydraulic oil lines where pressure exceeds 100R2 by at least 30%.	Oil resistant synthetic rubber tube. Two braids of high tensile steel wire reinforcement. Oil and extra abrasion resistant synthetic rubber cover.	AS 3791 100R2AT BCS 174 DIN 20022-2SN EN 853 Type 2SN ISO 1436 Types R2AT & 2SN SAE 100R2AT T2000 T7000 6000 (L000)
<b>SPIRAL</b>						
105	<b>H12D</b> DIEHARD™		<b>-06 to -40</b> 3/8" to 2.1/2"	Very high pressure hydraulic oil lines.	Oil resistant synthetic rubber tube. Four alternating layers of spiralled high tensile steel wire reinforcement. Oil and extra abrasion resistant synthetic rubber cover.	AS 3791 100R12 EN 856 Type R12 EN 856 Type 4SP (-12 and above) ISO 3862 Type R12 SAE 100R12 T7000
106	<b>H12S</b> SLIDER		<b>-06 to -32</b> 3/8" to 3"	Very high pressure hydraulic oil lines.	Oil resistant synthetic rubber tube. Four alternating layers of spiralled high tensile steel wire reinforcement. Synthetic rubber cover sheathed with a layer of extremely abrasion resistant polyethylene.	AS 3791 100R12 EN 856 Type R12 EN 856 Type 4SP (-12 and above) ISO 3862 Type R12 SAE 100R12 T7000
107	<b>R4SPD</b> DIEHARD™		<b>-06 to -16</b> 3/8" to 1"	Extra high pressure hydraulic oil lines.	Oil resistant synthetic rubber tube. Four alternating layers of spiralled high tensile steel wire reinforcement. Oil and extra abrasion resistant synthetic rubber cover.	EN 856 Type 4SP ISO 3862 Type 4SP T7000
108	<b>R4SHD</b> DIEHARD™		<b>-12 to -32</b> 3/4" to 2"	Extra high pressure hydraulic oil lines.	Oil resistant synthetic rubber tube. Four alternating layers of spiralled high tensile steel wire reinforcement. Oil and extra abrasion resistant synthetic rubber cover.	EN 856 Type 4SH ISO 3862 Type 4SH T6000 T7000
<b>SPECIALTY &amp; HIGH TEMPERATURE</b>						
110	<b>TJ2D</b> DIEHARD™ JACK		<b>-04 to -06</b> 1/4" & 3/8"	Hydraulic Jack applications requiring a light weight, small outside diameter hose.	Oil resistant synthetic rubber tube. Two braids of high tensile steel wire reinforcement. Oil and extra abrasion resistant synthetic rubber cover.	Materials Handling Institute specification IJ 100 (July 1979) T2000
111	<b>RQP1</b> SURVIVOR™		<b>-04 to -16</b> 1/4" to 1"	High pressure hydraulic oil applications.	Synthetic rubber tube, compounded for temperature resistance and multi fluid resistance. One braid of high tensile steel wire reinforcement. Oil resistant and abrasion resistant synthetic rubber cover.	AS 3791 100R1AT DIN 20022-1SN EN 853 Type 1SN ISO 1436 Types R1AT & 1SN SAE 100R1AT T2000 6000 (K000)
112	<b>RQP2</b> SURVIVOR™		<b>-04 to -32</b> 1/4" to 2"	High pressure hydraulic oil applications.	Synthetic rubber tube. Two braids of high tensile steel wire reinforcement. Oil resistant and abrasion resistant synthetic rubber cover.	AS 3791 100R2AT DIN 20022-2SN EN 853 Type 2SN ISO 1436 Types R2AT & 2SN SAE 100R2AT T2000 T7000 6000 (L000)
113	<b>RQP5</b> SURVIVOR™		<b>-04 to -32</b> 1/4" to 2"	Medium to high pressure hydraulic oil applications.	Oil resistant synthetic rubber tube. Polyester inner braid covered with one braid of high tensile steel wire reinforcement. Polyester braid cover.	AS 3791 100R5 SAE 100R5 SAE J1402 Type All (up to -12 size) T4000 V000
114	<b>RQP6</b> SURVIVOR™ PUSH-ON		<b>-04 to -12</b> 1/4" to 3/4"	Hydraulic oil lines, transmission oil cooler lines, glycol antifreeze solutions, water, diesel fuels and air.	Oil resistant synthetic rubber tube. One textile braid reinforcement. Oil resistant and abrasion resistant synthetic rubber cover.	AS 3791 100R6 DIN 20021-1TE ISO 4079 Type 1 SAE 100R6 T4000 8000

# HOSE

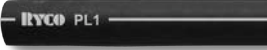
## PICTORIAL INDEX



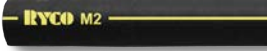
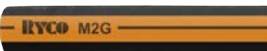





HOSE SERIES		INSIDE DIAMETER	RECOMMENDED	CONSTRUCTION	PERFORMANCE SPECIFICATIONS MET OR EXCEEDED	COUPLING SERIES
<b>SPECIALTY &amp; HIGH TEMPERATURE (CONT)</b>						
115	<b>D2B</b> DRILLER		-20 to -32 1.1/4" to 2"	Hydraulic oil or air lines. Drill rigs - high pressure, large bore air hose.	Oil resistant synthetic rubber tube. Two braids of high tensile steel wire reinforcement. Oil and abrasion resistant synthetic rubber cover.	T2000 T7000
116	<b>T5</b> TRUCKER		-04 to -32 1/4" to 2"	Medium to high pressure hydraulic oil applications.	Oil resistant synthetic rubber tube. Polyester inner braid covered with one braid of high tensile steel wire reinforcement. Polyester braid cover.	AS 3791 100R5 SAE 100R5 SAE J1402 Type All (up to -12 size) T4000 V000
117	<b>MS1000</b> MINESPRAY		-08 to -32 1/2" to 2"	Water and air spray suited for dust control in all industrial and mining applications.	Oil resistant synthetic rubber tube. One braid of high tensile steel wire reinforcement. Oil resistant and abrasion resistant synthetic rubber cover.	T2000
118	<b>CS1000</b> COALSPRAY		-08 to -32 1/2" to 2"	Water and air spray suited for dust control in all industrial and mining applications.	Oil resistant synthetic rubber tube. One braid of high tensile steel wire reinforcement. Oil resistant and abrasion resistant synthetic rubber cover.	T2000
120	<b>BT1</b> BIOTRANS		-04 to -16 1/4" to 1"	Transportation, marine fuel and engine hose applications.	Oil resistant synthetic rubber tube. One braid of high tensile steel wire reinforcement.	SAE J1527 Type Class I SAE J30R2 (non-marine) USCG SAE J1942 T2000 6000 (K000)
<b>HIGH PRESSURE WATERBLAST</b>						
121	<b>SW</b> SHOCKWAVE		-06 to -16 3/8" to 1"	Cleaning and preparation of marine surfaces, runway and swimming pool cleaning, and paint removal.	Oil and water resistant synthetic rubber tube. Four high tensile steel spirals reinforcement. Oil, water and ozone resistant synthetic rubber cover.	AS/NZS 4233.2 EN 1829-2 ISO 7751 TW4000
<b>PRESSURE WASHER</b>						
122	<b>JS4000</b> <b>JS4000G</b> JETSTORM	 	-04 to -08 1/4" to 1/2"	Cleaning and preparation of marine surfaces, runway and swimming pool cleaning, and paint removal. JS4000G is Animal Fat Resistant (AFR).	Oil and water resistant synthetic rubber tube. One braid of high tensile steel spiral reinforcement. Oil, water and ozone resistant synthetic rubber cover.	EN 1829-2 T2000
123	<b>JS4000BX</b> <b>JS4000GX</b> JETSTORM	 	-04 to -08 1/4" to 1/2"	Cleaning and preparation of marine surfaces, runway and swimming pool cleaning, and paint removal.	Oil and water resistant synthetic rubber tube. One braid of high tensile steel spiral reinforcement. Oil, water and ozone resistant synthetic rubber cover.	EN 1829-2 T2000
124	<b>JS6000</b> <b>JS6000G</b> JETSTORM	 	-04 to -08 1/4" to 1/2"	Cleaning & preparation of marine surfaces, runway and swimming pool cleaning, and paint removal. JS6000G is Animal Fat Resistant (AFR).	Oil and water resistant synthetic rubber tube. Two braids of high tensile steel spiral reinforcement. Oil, water and ozone resistant synthetic rubber cover.	EN 1829-2 T2000
125	<b>JS6000BX</b> <b>JS6000GX</b> JETSTORM	 	-04 to -08 1/4" to 1/2"	Cleaning and preparation of marine surfaces, runway and swimming pool cleaning, and paint removal.	Oil and water resistant synthetic rubber tube. Two braids of high tensile steel spiral reinforcement. Oil, water and ozone resistant synthetic rubber cover.	EN 1829-2 T2000
<b>SUCTION AND RETURN</b>						
126	<b>SRF</b> COMPACT SUCTION		-12 to -32 3/4" to 2"	Petroleum and water base hydraulic fluids in suction lines or in low pressure return lines.	Oil resistant synthetic rubber tube. Textile reinforcement with spiral wire to prevent collapsing. Oil resistant and abrasion resistant synthetic rubber cover.	AS 3791 100R4 SAE 100R4 33000 T4000



HOSE SERIES		INSIDE DIAMETER	RECOMMENDED	CONSTRUCTION	PERFORMANCE SPECIFICATIONS MET OR EXCEEDED	COUPLING SERIES
<b>SUCTION AND RETURN (CONT)</b>						
127	<b>SRX</b> COMPACT SUCTION		<b>-12 to -48</b> 3/4" to 3"	Petroleum and water base hydraulic fluids in suction lines or in low pressure return lines where extreme flexibility is required.	Oil resistant synthetic rubber tube. Textile reinforcement with spiral wire to prevent collapsing. Oil resistant and abrasion resistant synthetic rubber cover. Extremely flexible.	AS 3791 100R4 SAE 100R4  33000 T4000
<b>TEFLON®</b>						
128	<b>RTH1</b> TEFLON®		<b>-04 to -16</b> 1/4" to 1"	High pressure hydraulic oil lines. Fluids at extremes of pressure and temperature.	PTFE tube (TEFLON®). One braid of high tensile Grade 304 stainless steel wire reinforcement. *DuPont Reg. TM	SAE 100R14. RTH112 meets ID and OD requirements of SAE 100R14. Other sizes have ID and OD different to SAE 100R14  TT000
<b>TEXTILE BRAID</b>						
129	<b>PL1</b> DIEHARD™		<b>-04 to -12</b> 1/4" to 3/4"	Petroleum base hydraulic oils, glycol antifreeze solutions, water, diesel fuels, and air.	Oil resistant synthetic rubber tube. One textile braid reinforcement. Oil and abrasion resistant synthetic rubber cover.	AS 3791 100R6 DIN 20021-1TE ISO 4079 Type 1 SAE 100R6  T4000 8000
130	<b>PL1D</b> DIEHARD™		<b>-04 to -12</b> 1/4" to 3/4"	Petroleum base hydraulic oils, glycol antifreeze solutions, water, diesel fuels, and air.	Oil resistant synthetic rubber tube. One textile braid reinforcement. Oil and abrasion resistant synthetic rubber cover.	AS 3791 100R6 DIN 20021-1TE ISO 4079 Type R6 SAE 100R6  T4000 8000
131	<b>PL1PV</b> PUSH ON		<b>-04 to -12</b> 1/4" to 3/4"	Petroleum base hydraulic oils, glycol antifreeze solutions, water, diesel fuels, and air.	Oil resistant synthetic rubber tube. One textile braid reinforcement. Oil and abrasion resistant synthetic rubber cover.	AS 3791 100R6 ISO 4079 Type 1 SAE 100R6  T4000 8000
132	<b>M1</b> FUEL LINE		<b>-04 to -06</b> 1/4" to 3/8"	Multi-purpose hose for use on fuel lines, PCV and EEC systems, and fuel return hose connections on diesel fuel injection systems.	Oil resistant synthetic rubber tube. One textile braid reinforcement. Oil resistant synthetic rubber cover.	SAE 30R7  N/A
133	<b>MP1</b> MULTI-PURPOSE		<b>-04 to -20</b> 1/4" to 1.1/4"	Air, water, petroleum oils, kerosene and fuel oils.	Oil resistant synthetic rubber tube. One textile braid reinforcement. Oil resistant and abrasion resistant synthetic rubber cover.	RMA Class A (tube) RMA Class B (cover)  T4000
134	<b>M2</b> TEXTILE		<b>-04 to -16</b> 1/4" to 1"	Medium pressure hydraulic oil lines, antifreeze solutions, water.	Oil resistant synthetic rubber tube. Two textile braids reinforcement. Oil resistant and abrasion resistant synthetic rubber cover.	AS 3791 100R3 DIN 20021-2TE ISO 4079 Type R3 SAE 100R3  T4000 6000 (M000)
135	<b>M2G</b> LPG/C		<b>-04 to -12</b> 1/4" to 3/4"	Liquefied Petroleum Gas and Natural Gas.	Oil resistant synthetic rubber tube. Two textile braids reinforcement. Abrasion resistant synthetic rubber perforated cover.	AS/NZS 1869 Class C  T4000 6000 (M000)
<b>THERMOPLASTIC</b>						
138	<b>TP7</b> SPIDERLINE R7		<b>-03 to -16</b> 3/16" to 1"	High pressure hydraulic oil lines; pilot lines; greasing and lubrication lines; and some pneumatic and water lines.	Oil resistant seamless thermoplastic tube. One or two braids of synthetic fibre reinforcement. Oil and abrasion resistant thermoplastic perforated cover.	AS 3791 100R7 EN 855 TYPE R7 ISO 3949 TYPE R7 SAE 100R7  TP000
139	<b>TP7N</b> ISOLATOR R7		<b>-04 to -16</b> 1/4" to 1"	Hydraulic oil lines where electrical non-conductivity is required.	Oil resistant seamless thermoplastic tube. One or two braids of synthetic fibre reinforcement. Oil and abrasion resistant thermoplastic cover.	AS 3791 100R7 EN 855 TYPE R7 ISO 3949 TYPE R7 SAE 100R7  TP000

# HOSE

## PICTORIAL INDEX

HOSE SERIES		INSIDE DIAMETER	RECOMMENDED	CONSTRUCTION	PERFORMANCE SPECIFICATIONS MET OR EXCEEDED	COUPLING SERIES	
<b>THERMOPLASTIC (CONT)</b>							
140	<b>TP7T</b> SPIDERLINE TWIN R7		<b>-04 to -08</b> 1/4" to 1/2"	Payout and return reels on forklifts and cranes, dispensing equipment and other applications requiring two hoses.	Oil resistant seamless thermoplastic tube. One or two braids of synthetic fibre reinforcement. Oil and abrasion resistant thermoplastic perforated cover.	AS 3791 100R7 EN 855 TYPE R7 ISO 3949 TYPE R7 SAE 100R7	TP000
141	<b>TP7TN</b> ISOLATOR TWIN R7		<b>-04 to -08</b> 1/4" to 1/2"	Payout and return reels on forklifts and cranes, hydraulic powered hand tools and other applications requiring two hoses.	Oil resistant seamless thermoplastic tube. One or two braids of synthetic fibre reinforcement. Oil and abrasion resistant thermoplastic cover.	AS 3791 100R7 EN 855 TYPE R7 ISO 3949 TYPE R7 SAE 100R7	TP000
142	<b>TP8</b> SPIDERLINE R8		<b>-04 to -08</b> 1/4" to 1/2"	High pressure hydraulic oil lines; pilot lines; greasing and lubrication lines; and some pneumatic and water lines.	Oil resistant seamless thermoplastic tube. One or two braids of aramid fibre reinforcement. Oil and abrasion resistant thermoplastic perforated cover.	AS 3791 100R8 EN 855 TYPE R8 ISO 3949 TYPE R8 SAE 100R8	TP000
143	<b>TP8N</b> ISOLATOR R8		<b>-04 to -08</b> 1/4" to 1/2"	Hydraulic oil lines where electrical non-conductivity is required.	Oil resistant seamless thermoplastic tube. One or two braids of aramid fibre reinforcement. Oil and abrasion resistant thermoplastic cover.	AS 3791 100R8 EN 855 TYPE R8 ISO 3949 TYPE R8 SAE 100R8	TP000
144	<b>TP8T</b> SPIDERLINE TWIN R8		<b>-04 to -08</b> 1/4" to 1/2"	Payout and return reels on forklifts and cranes, dispensing equipment and other applications requiring two hoses.	Oil resistant seamless thermoplastic tube. One or two braids of aramid fibre reinforcement. Oil and abrasion resistant thermoplastic perforated cover.	AS 3791 100R8 EN 855 TYPE R8 ISO 3949 TYPE R8 SAE 100R8	TP000
145	<b>TP8TN</b> ISOLATOR TWIN R8		<b>-04 to -08</b> 1/4" to 1/2"	Payout and return reels on forklifts and cranes, hydraulic powered hand tools and other applications requiring two hoses.	Oil resistant seamless thermoplastic tube. One or two braids of aramid fibre reinforcement. Oil and abrasion resistant thermoplastic cover.	AS 3791 100R8 EN 855 Type R8 ISO 3949 TYPE R8 SAE 100R8	TP000
146	<b>TP3000</b> SPIDERLINE R18		<b>-04 to -08</b> 1/4" to 1/2"	Medium pressure hose suitable for petroleum or synthetic based hydraulic fluids in forklift systems.	Polyester elastomer tube. One or two braids of synthetic fibre reinforcement. Special polyester, black with white ink-jet branding. Cover is perforated (pin-pricked).	SAE 100 R18	TP000
<b>GREASING AND LUBRICATION</b>							
147	<b>TPGL</b> GREASE LINE		<b>-02</b> 1/8"	High pressure greasing and lubrication systems.	Oil resistant seamless thermoplastic tube. One or two braids of synthetic fibre reinforcement. Oil and abrasion resistant thermoplastic perforated cover.		TG000 6000 (P000)
148	<b>R4100N</b>		<b>-03</b> 3/16"	Flexible Grease Gun extension for high pressure greasing and lubrication systems.	Oil resistant synthetic rubber tube. One braid of high tensile steel wire reinforcement. Oil and abrasion resistant synthetic rubber cover.		

HOSE PROTECTION		INSIDE DIAMETER	RECOMMENDED	CONSTRUCTION	PERFORMANCE SPECIFICATIONS MET OR EXCEEDED
150	<b>FS</b> FIRE SLEEVE 	-08 to -104 1/2" to 6.1/2"	Protection of hoses from heat and molten metal splashes.	Braided glass fibre tubing coated with silicon rubber.	SAE Aerospace Standard AS 1072
153	<b>RCS</b> CROCSLEEVE 	23 to 129 mm 7/8" to 5"	Burst and pinhole protection. Protection of hoses from abrasion. Bundling hoses together.	Woven polyamide. RCSB - Black. RCSR - Red.	MSHA approved FRAS
156	<b>RH</b> RAWHIDE 	23 to 93 mm 7/8" to 3.5/8"	Protection of hoses from severe abrasion. Bundling hoses together.	Woven nylon tubing.	MSHA approved
157	<b>RSG</b> SPIRAL GUARD 	16 to 110 mm (OD) 5/8" to 4.1/2"	Protection of hoses from abrasion and impact. Bundling hoses together.	Polyethylene plastic spiral. Black.	
157	<b>RSGF</b> SPIRAL GUARD FRAS 	16 to 110 mm (OD) 5/8" to 4.1/2"	Protection of hoses from abrasion and impact. Bundling hoses together.	Polyethylene plastic spiral. Dark Grey.	MSHA approved FRAS
157	<b>RSGY</b> SPIRAL GUARD 	16 to 110 mm (OD) 5/8" to 4.1/2"	Protection of hoses from abrasion and impact. Bundling hoses together.	Polyethylene plastic spiral. Yellow	
159	<b>RWA</b> PUSH ON 	12 to 75 mm 1/2" to 3"	Protection of hose cover from abrasion and gouges.	Spring Steel Wire, galvanised.	
161	<b>RHYS</b> PACKAGING SLEEVE 	48 & 79 mm 1.9" and 3.1"	Packaging and protection of hose assemblies during transport and storage.	Heavy duty, low density polyethylene sleeve.	
163	<b>GRAM</b> GRAM LABEL 	Suits sizes -04 to -20 & -12 to -32	Permanent identification of hose assemblies.	High performance plastic.	
164	<b>RHYT</b> RHYT-10, -32 	Suits sizes -04 to -10 & -12 to -32	Permanent identification of hose assemblies.	High performance plastic.	
164	<b>RHWT</b> RHWT-10, -32 	Suits sizes -04 to -10 & -12 to -32	Permanent identification of hose assemblies.	High performance plastic.	
162	<b>750/760</b> SPRING GUARD 	Suits some -04 (1/4") & -06 (3/8") hoses	Control bend radius at end of hose assemblies.	Spring Steel Wire, galvanised.	

INTRODUCTION

HOSE

COUPLINGS

ADAPTORS

TECHNICAL



# HOSE

## HOSE TYPE APPROVALS

The tables following on pages 44 to 48 list the approvals RYCO Hydraulics hold with various third parties for hoses used in RYCO Matched Hose Assemblies. For each Certification Body/Organisation referenced in the table, listed is; the Matched RYCO Coupling Series approved for the hoses listed.

### EXAMPLE:

A Hose Assembly using **T3600D** needs to meet **Marine Equipment Directive (MED)** approval; the table shows: The **Matched Couplings** approved for use with **T3600D** hose: **T2000** Series Crimp Couplings.

\* Refer to [www.RYCO.com.au](http://www.RYCO.com.au) for current approval certificates & further details.

RYCO HOSE TYPE APPROVALS																
HOSE SERIES	DIEHARD	SLIDER	SURVIVOR	ENERGY	ICEBREAKER	ABS	DNV-GL	LR	MED	USCG	CLASSNK	GOST-R	BV	RINA	KR	MA-KA
T3000	D	S	Sv	E	I											
T3004	•					T2000	T2000	T2000	T2000	T2000	T2000	T2000	T2000	T2000	T2000	T2000
T3005	•					T2000	T2000	T2000	T2000	T2000	T2000	T2000	T2000	T2000	T2000	T2000
T3006	•					T2000	T2000	T2000	T2000	T2000	T2000	T2000	T2000	T2000	T2000	T2000
T3008	•					T2000	T2000	T2000	T2000	T2000	T2000	T2000	T2000	T2000	T2000	T2000
T3010	•					T2000	T2000	T2000	T2000	T2000	T2000	T2000	T2000	T2000	T2000	T2000
T3012	•					T2000	T2000	T2000	T2000	T2000	T2000	T2000	T2000	T2000	T2000	T2000
T3016	•					T2000	T2000	T2000	T2000	T2000	T2000	T2000	T2000	T2000	T2000	T2000
T3600	D	S	Sv	E	I											
T3604	•	•			•	T2000	T2000	T2000	T2000	T2000		T2000	T2000	T2000	T2000	T2000
T3605	•	•			•	T2000	T2000	T2000	T2000	T2000		T2000	T2000	T2000	T2000	T2000
T3606	•	•			•	T2000	T2000	T2000	T2000	T2000		T2000	T2000	T2000	T2000	T2000
T3608	•	•			•	T2000	T2000	T2000	T2000	T2000		T2000	T2000	T2000	T2000	T2000
T3610	•	•			•	T2000	T2000	T2000	T2000	T2000		T2000	T2000	T2000	T2000	T2000
T3612	•	•			•	T2000	T2000	T2000	T2000	T2000		T2000	T2000	T2000	T2000	T2000
T3616	•	•			•	T2000	T2000	T2000	T2000	T2000		T2000	T2000	T2000	T2000	T2000
T4000	D	S	Sv	E	I											
T4004	•	•				T2000	T2000	T2000	T2000	T2000		T2000	T2000	T2000	T2000	T2000
T4005	•	•				T2000	T2000	T2000	T2000	T2000		T2000	T2000	T2000	T2000	T2000
T4006	•	•				T2000	T2000	T2000	T2000	T2000		T2000	T2000	T2000	T2000	T2000
T4008	•	•				T2000	T2000	T2000	T2000	T2000		T2000	T2000	T2000	T2000	T2000
T4010	•	•				T2000	T2000	T2000	T2000	T2000		T2000	T2000	T2000	T2000	T2000
T4012	•	•				T2000	T2000	T2000	T2000	T2000		T2000	T2000	T2000	T2000	T2000
T5000	D	S	Sv	E	I											
T5004	•	•				T2000	T2000	T2000	T2000	T2000		T2000	T2000	T2000	T2000	T2000
T5005	•	•				T2000	T2000	T2000	T2000	T2000		T2000	T2000	T2000	T2000	T2000
T5006	•	•				T2000	T2000	T2000	T2000	T2000		T2000	T2000	T2000	T2000	T2000
T5008	•	•				T2000	T2000	T2000	T2000	T2000		T2000	T2000	T2000	T2000	T2000

Refer to [www.RYCO.com.au](http://www.RYCO.com.au) for current approval certificates & further details.

## HOSE TYPE APPROVALS

RYCO HOSE TYPE APPROVALS																
HOSE SERIES	DIEHARD	SLIDER	SURVIVOR	ENERGY	ICEBREAKER	ABS	DNV-GL	LR	MED	USCG	DOT	GOST-R	BV	RINA	KR	MA-KA
<b>T6000</b>	D	S	Sv	E	I											
<b>T6004</b>	•	•				T2000	T2000	T2000	T2000	T2000		T2000	T2000	T2000	T2000	
<b>T6005</b>	•	•				T2000	T2000	T2000	T2000	T2000		T2000	T2000	T2000	T2000	
<b>T6006</b>	•	•				T2000	T2000	T2000	T2000	T2000		T2000	T2000	T2000	T2000	
<b>H3000</b>	D	S	Sv	E	I											
<b>H3020</b>	•	•				T7000	T7000	T7000	T7000	T7000		T7000	T7000	T7000	T7000	
<b>H3024</b>	•	•				T7000	T7000	T7000	T7000	T7000		T7000	T7000	T7000	T7000	
<b>H3032</b>	•	•				T7000	T7000	T7000	T7000	T7000		T7000	T7000	T7000	T7000	
<b>H4000</b>	D	S	Sv	E	I											
<b>H4006</b>	•	•				T7000	T7000	T7000	T7000	T7000		T7000	T7000	T7000	T7000	
<b>H4008</b>	•	•				T7000	T7000	T7000	T7000	T7000		T7000	T7000	T7000	T7000	
<b>H4010</b>	•	•				T7000	T7000	T7000	T7000	T7000		T7000	T7000	T7000	T7000	
<b>H4012</b>	•	•				T7000	T7000	T7000	T7000	T7000		T7000	T7000	T7000	T7000	
<b>H4016</b>	•	•				T7000	T7000	T7000	T7000	T7000		T7000	T7000	T7000	T7000	
<b>H4020</b>	•	•				T7000	T7000	T7000	T7000	T7000		T7000	T7000	T7000	T7000	
<b>H4024</b>	•	•				T7000	T7000	T7000	T7000	T7000		T7000	T7000	T7000	T7000	
<b>H4032</b>	•	•				T7000	T7000	T7000	T7000	T7000		T7000	T7000	T7000	T7000	
<b>H5000</b>	D	S	Sv	E	I											
<b>H5006</b>	•	•				T7000	T7000	T7000	T7000	T7000		T7000	T7000	T7000	T7000	
<b>H5008</b>	•	•				T7000	T7000	T7000	T7000	T7000		T7000	T7000	T7000	T7000	
<b>H5010</b>	•	•				T7000	T7000	T7000	T7000	T7000		T7000	T7000	T7000	T7000	
<b>H5012</b>	•	•			•	T7000	T7000	T7000	T7000	T7000		T7000	T7000	T7000	T7000	
<b>H5016</b>	•	•			•	T7000	T7000	T7000	T7000	T7000		T7000	T7000	T7000	T7000	
<b>H5020</b>	•	•			•	T7000	T7000	T7000	T7000	T7000		T7000	T7000	T7000	T7000	
<b>H5024</b>	•	•			•	T6000 & T7000	T6000 & T7000	T6000 & T7000	T6000 & T7000	T6000 & T7000		T6000 & T7000	T6000 & T7000	T6000 & T7000	T6000 & T7000	
<b>H5032</b>	•	•				T6000	T6000	T6000	T6000	T6000		T6000	T6000	T6000	T6000	
<b>H6000</b>	D	S	Sv	E	I											
<b>H6006</b>	•	•				T7000	T7000	T7000	T7000	T7000		T7000	T7000	T7000	T7000	
<b>H6008</b>	•	•				T7000	T7000	T7000	T7000	T7000		T7000	T7000	T7000	T7000	
<b>H6010</b>	•	•				T7000	T7000	T7000	T7000	T7000		T7000	T7000	T7000	T7000	
<b>H6012</b>	•	•				T6000 & T7000	T6000 & T7000	T6000 & T7000	T6000 & T7000	T6000 & T7000		T6000 & T7000	T6000 & T7000	T6000 & T7000	T6000 & T7000	
<b>H6016</b>	•	•				T6000 & T7000	T6000 & T7000	T6000 & T7000	T6000 & T7000	T6000 & T7000		T6000 & T7000	T6000 & T7000	T6000 & T7000	T6000 & T7000	
<b>H6020</b>	•	•				T6000 & T7000	T6000 & T7000	T6000 & T7000	T6000 & T7000	T6000 & T7000		T6000 & T7000	T6000 & T7000	T6000 & T7000	T6000 & T7000	
<b>H6024</b>	•	•				T6000	T6000	T6000	T6000	T6000		T6000	T6000	T6000	T6000	
<b>H6032</b>	•	•				T6000	T6000	T6000	T6000	T6000		T6000	T6000	T6000	T6000	

INTRODUCTION

HOSE

COUPLINGS

ADAPTORS

TECHNICAL

Refer to [www.RYCO.com.au](http://www.RYCO.com.au) for current approval certificates & further details.

## HOSE TYPE APPROVALS

HOSE SERIES	RYCO HOSE TYPE APPROVALS														
	DIEHARD	SLIDER	SURVIVOR	ENERGY	ICEBREAKER	ABS	DNV-GL	LR	MED	USCG	DOT	GOST-R	BV	RINA	KR

DF1	D	S	Sv	E	I												
DF14	•					T2000	T2000	T2000	T2000	T2000		T2000	T2000	T2000	T2000		
DF15	•					T2000	T2000	T2000	T2000	T2000		T2000	T2000	T2000	T2000		
DF16	•					T2000	T2000	T2000	T2000	T2000		T2000	T2000	T2000	T2000		
DF18	•					T2000	T2000	T2000	T2000	T2000		T2000	T2000	T2000	T2000		
DF110	•					T2000	T2000	T2000	T2000	T2000		T2000	T2000	T2000	T2000		
DF112	•					T2000	T2000	T2000	T2000	T2000		T2000	T2000	T2000	T2000		
DF116	•					T2000	T2000	T2000	T2000	T2000		T2000	T2000	T2000	T2000		

DF2	D	S	Sv	E	I												
DF24	•					T2000	T2000	T2000	T2000	T2000		T2000	T2000	T2000	T2000		
DF25	•					T2000	T2000	T2000	T2000	T2000		T2000	T2000	T2000	T2000		
DF26	•					T2000	T2000	T2000	T2000	T2000		T2000	T2000	T2000	T2000		
DF28	•					T2000	T2000	T2000	T2000	T2000		T2000	T2000	T2000	T2000		
DF210	•					T2000	T2000	T2000	T2000	T2000		T2000	T2000	T2000	T2000		
DF212	•					T2000	T2000	T2000	T2000	T2000		T2000	T2000	T2000	T2000		
DF216	•					T2000	T2000	T2000	T2000	T2000		T2000	T2000	T2000	T2000		
DF220	•					T2000				T2000		T2000			T2000		

T1	D	S	Sv	E	I												
T13	•	•				T2000	T2000	T2000	T2000	T2000		T2000	T2000	T2000	T2000	T2000	
T14	•	•				T2000	T2000	T2000	T2000	T2000		T2000	T2000	T2000	T2000	T2000	
T15	•	•				T2000	T2000	T2000	T2000	T2000		T2000	T2000	T2000	T2000	T2000	
T16	•	•				T2000	T2000	T2000	T2000	T2000		T2000	T2000	T2000	T2000	T2000	
T18	•	•				T2000	T2000	T2000	T2000	T2000		T2000	T2000	T2000	T2000	T2000	
T110	•	•				T2000	T2000	T2000	T2000	T2000		T2000	T2000	T2000	T2000	T2000	
T112	•	•				T2000	T2000	T2000	T2000	T2000		T2000	T2000	T2000	T2000	T2000	
T116	•	•				T2000	T2000	T2000	T2000	T2000		T2000	T2000	T2000	T2000	T2000	
T120	•	•				T2000	T2000	T2000	T2000	T2000		T2000	T2000	T2000	T2000	T2000	
T124	•	•				T2000	T2000	T2000	T2000	T2000		T2000	T2000	T2000	T2000	T2000	
T132	•	•				T2000	T2000	T2000	T2000	T2000		T2000	T2000	T2000	T2000	T2000	

T1F	D	S	Sv	E	I												
T13F						T2000	T2000	T2000	T2000	T2000		T2000	T2000	T2000	T2000		
T14F						T2000	T2000	T2000	T2000	T2000		T2000	T2000	T2000	T2000		
T16F						T2000	T2000	T2000	T2000	T2000		T2000	T2000	T2000	T2000		
T18F						T2000	T2000	T2000	T2000	T2000		T2000	T2000	T2000	T2000		
T112F						T2000	T2000	T2000	T2000	T2000		T2000	T2000	T2000	T2000		

T2	D	S	Sv	E	I												
T24	•	•			•	T2000	T2000	T2000	T2000	T2000		T2000	T2000	T2000	T2000	T2000	
T25	•	•			•	T2000	T2000	T2000	T2000	T2000		T2000	T2000	T2000	T2000	T2000	
T26	•	•			•	T2000 & T7000	T2000 & T7000	T2000 & T7000	T2000 & T7000	T2000 & T7000		T2000 & T7000	T2000 & T7000	T2000 & T7000	T2000 & T7000	T2000 & T7000	
T28	•	•			•	T2000 & T7000	T2000 & T7000	T2000 & T7000	T2000 & T7000	T2000 & T7000		T2000 & T7000	T2000 & T7000	T2000 & T7000	T2000 & T7000	T2000 & T7000	
T210	•	•			•	T2000 & T7000	T2000 & T7000	T2000 & T7000	T2000 & T7000	T2000		T2000 & T7000	T2000 & T7000	T2000 & T7000	T2000 & T7000	T2000 & T7000	
T212	•	•			•	T2000 & T7000	T2000 & T7000	T2000 & T7000	T2000 & T7000	T2000 & T7000		T2000 & T7000	T2000 & T7000	T2000 & T7000	T2000 & T7000	T2000 & T7000	
T216	•	•			•	T2000 & T7000	T2000 & T7000	T2000 & T7000	T2000 & T7000	T7000		T2000 & T7000	T2000 & T7000	T2000 & T7000	T2000 & T7000	T2000 & T7000	
T220	•	•			•	T2000 & T7000	T2000 & T7000	T2000 & T7000	T2000 & T7000	T7000		T2000 & T7000	T2000 & T7000	T2000 & T7000	T2000 & T7000	T2000 & T7000	
T224	•	•			•	T7000	T7000	T7000	T7000	T7000		T7000	T7000	T7000	T7000	T7000	
T232	•	•			•	T7000	T7000	T7000	T7000	T7000		T7000	T7000	T7000	T7000	T7000	



## HOSE TYPE APPROVALS

RYCO HOSE TYPE APPROVALS																
HOSE SERIES	DIEHARD	SLIDER	SURVIVOR	ENERGY	ICEBREAKER	ABS	DNV-GL	LR	MED	USCG	DOT	GOST-R	BV	RINA	KR	MA-KA
<b>TXA2D</b>	D	S	Sv	E	I											
<b>TXA28D</b>	•					T2000	T2000	T2000	T2000	T2000		T2000	T2000	T2000	T2000	
<b>TXA210D</b>	•					T2000	T2000	T2000	T2000	T2000		T2000	T2000	T2000	T2000	
<b>TXA212D</b>	•					T2000	T2000	T2000	T2000	T2000		T2000	T2000	T2000	T2000	
<b>TXA216D</b>	•					T2000	T2000	T2000	T2000	T2000		T2000	T2000	T2000	T2000	
<b>H12</b>	D	S	Sv	E	I											
<b>H1206</b>	•	•				T7000	T7000	T7000	T7000	T7000		T7000	T7000	T7000	T7000	
<b>H1208</b>	•	•				T7000	T7000	T7000	T7000	T7000		T7000	T7000	T7000	T7000	
<b>H1210</b>	•	•				T7000	T7000	T7000	T7000	T7000		T7000	T7000	T7000	T7000	
<b>H1212</b>	•	•				T7000	T7000	T7000	T7000	T7000		T7000	T7000	T7000	T7000	
<b>H1216</b>	•	•				T7000	T7000	T7000	T7000	T7000		T7000	T7000	T7000	T7000	
<b>H1220</b>	•	•				T7000	T7000	T7000	T7000	T7000		T7000	T7000	T7000	T7000	
<b>H1224</b>	•	•				T7000	T7000	T7000	T7000	T7000		T7000	T7000	T7000	T7000	
<b>H1232</b>	•	•				T7000	T7000	T7000	T7000	T7000		T7000	T7000	T7000	T7000	
<b>R4SP</b>	D	S	Sv	E	I											
<b>R4SP06</b>	•					T7000	T7000	T7000	T7000	T7000		T7000	T7000	T7000	T7000	T7000
<b>R4SP08</b>	•					T7000	T7000	T7000	T7000	T7000		T7000	T7000	T7000	T7000	T7000
<b>R4SP08</b>	•					T7000	T7000	T7000	T7000	T7000		T7000	T7000	T7000	T7000	T7000
<b>R4SP10</b>						T7000	T7000	T7000	T7000	T7000		T7000	T7000	T7000	T7000	T7000
<b>R4SP12</b>	•					T7000	T7000	T7000	T7000	T7000		T7000	T7000	T7000	T7000	T7000
<b>R4SP16</b>	•					T7000	T7000	T7000	T7000	T7000		T7000	T7000	T7000	T7000	T7000
<b>R4SH</b>	D	S	Sv	E	I											
<b>R4SH12</b>	•					T7000	T7000	T7000	T7000	T7000		T7000	T7000	T7000	T7000	T7000
<b>R4SH16</b>	•					T6000	T6000	T6000	T6000	T6000		T6000	T6000	T6000	T6000	T6000
<b>R4SH20</b>	•					T7000	T7000	T7000	T7000	T7000		T7000	T7000	T7000	T7000	T7000
<b>R4SH24</b>	•					T7000	T7000	T7000	T7000	T7000		T7000	T7000	T7000	T7000	T7000
<b>R4SH32</b>	•					T7000	T7000	T7000	T7000	T7000		T7000	T7000	T7000	T7000	T7000
<b>RQP1</b>	D	S	Sv	E	I											
<b>RQP14</b>			•			T2000	T2000	T2000	T2000	T2000		T2000	T2000	T2000	T2000	
<b>RQP15</b>			•			T2000	T2000	T2000	T2000	T2000		T2000	T2000	T2000	T2000	
<b>RQP16</b>			•			T2000	T2000	T2000	T2000	T2000		T2000	T2000	T2000	T2000	
<b>RQP18</b>			•			T2000	T2000	T2000	T2000	T2000		T2000	T2000	T2000	T2000	
<b>RQP110</b>			•			T2000	T2000	T2000	T2000	T2000		T2000	T2000	T2000	T2000	
<b>RQP112</b>			•			T2000	T2000	T2000	T2000	T2000		T2000	T2000	T2000	T2000	
<b>RQP116</b>			•			T2000	T2000	T2000	T2000	T2000		T2000	T2000	T2000	T2000	

INTRODUCTION

HOSE











COUPLINGS

ADAPTORS

TECHNICAL

Refer to [www.RYCO.com.au](http://www.RYCO.com.au) for current approval certificates & further details.

## HOSE TYPE APPROVALS

RYCO HOSE TYPE APPROVALS																
HOSE SERIES	DIEHARD	SLIDER	SURVIVOR	ENERGY	ICEBREAKER											
RQP2	D	S	Sv	E	I											
RQP24			•			T2000	T2000	T2000	T2000	T2000		T2000	T2000	T2000	T2000	
RQP25			•			T2000	T2000	T2000	T2000	T2000		T2000	T2000	T2000	T2000	
RQP26			•			T2000 & T7000	T2000 & T7000	T2000 & T7000	T2000 & T7000	T2000 & T7000		T2000 & T7000	T2000 & T7000	T2000 & T7000	T2000 & T7000	
RQP28			•			T2000 & T7000	T2000 & T7000	T2000 & T7000	T2000 & T7000	T2000 & T7000		T2000 & T7000	T2000 & T7000	T2000 & T7000	T2000 & T7000	
RQP210			•			T2000 & T7000	T2000 & T7000	T2000 & T7000	T2000 & T7000	T2000 & T7000		T2000 & T7000	T2000 & T7000	T2000 & T7000	T2000 & T7000	
RQP212			•			T2000 & T7000	T2000 & T7000	T2000 & T7000	T2000 & T7000	T2000 & T7000		T2000 & T7000	T2000 & T7000	T2000 & T7000	T2000 & T7000	
RQP216			•			T2000 & T7000	T2000 & T7000	T2000 & T7000	T2000 & T7000	T2000 & T7000		T2000 & T7000	T2000 & T7000	T2000 & T7000	T2000 & T7000	
RQP220			•			T2000 & T7000	T2000 & T7000	T2000 & T7000	T2000 & T7000	T7000		T7000	T2000 & T7000	T2000 & T7000	T2000 & T7000	
RQP224			•			T7000	T7000	T7000	T7000	T7000		T7000	T7000	T7000	T7000	
*RQP5	D	S	Sv	E	I											
RQP54						T4000	T4000	T4000	T4000	T4000	T4000	T4000	T4000	T4000	T4000	
RQP55						T4000	T4000	T4000	T4000	T4000	T4000	T4000	T4000	T4000	T4000	
RQP56						T4000	T4000	T4000	T4000	T4000	T4000	T4000	T4000	T4000	T4000	
RQP58						T4000	T4000	T4000	T4000	T4000	T4000	T4000	T4000	T4000	T4000	
RQP510						T4000	T4000	T4000	T4000	T4000	T4000	T4000	T4000	T4000	T4000	
RQP512						T4000	T4000	T4000	T4000	T4000	T4000	T4000	T4000	T4000	T4000	
RQP516						T4000	T4000	T4000	T4000	T4000	T4000	T4000	T4000	T4000	T4000	
RQP520						V000	V000	V000	V000	V000	V000	V000	V000	V000	V000	
RQP524						V000	V000	V000	V000	V000	V000	V000	V000	V000	V000	
RQP532						V000	V000	V000	V000	V000	V000	V000	V000	V000	V000	
D2B	D	S	Sv	E	I											
D220B			•			T7000	T7000	T7000	T7000	T7000		T7000	T7000	T7000	T7000	
D224B			•			T7000 & T2000	T7000 & T2000	T7000 & T2000	T7000 & T2000	T7000 & T2000		T7000 & T2000	T7000 & T2000	T7000 & T2000	T7000 & T2000	
D232B			•			T7000 & T2000	T7000 & T2000	T7000 & T2000	T7000 & T2000	T7000 & T2000		T7000 & T2000	T7000 & T2000	T7000 & T2000	T7000 & T2000	
*T5	D	S	Sv	E	I											
T54						T4000	T4000	T4000	T4000	T4000	T4000	T4000	T4000	T4000	T4000	
T55						T4000	T4000	T4000	T4000	T4000	T4000	T4000	T4000	T4000	T4000	
T56						T4000	T4000	T4000	T4000	T4000	T4000	T4000	T4000	T4000	T4000	
T58						T4000	T4000	T4000	T4000	T4000	T4000	T4000	T4000	T4000	T4000	
T510						T4000	T4000	T4000	T4000	T4000	T4000	T4000	T4000	T4000	T4000	
T512						T4000	T4000	T4000	T4000	T4000	T4000	T4000	T4000	T4000	T4000	
T516						T4000	T4000	T4000	T4000	T4000	T4000	T4000	T4000	T4000	T4000	
T520						T4000	T4000	T4000	T4000	T4000	T4000	T4000	T4000	T4000	T4000	
T524						V000	V000	V000	V000	V000	V000	V000	V000	V000	V000	
T532						V000	V000	V000	V000	V000	V000	V000	V000	V000	V000	

\* NOTE: For marine application Type Approval compliance, FS1072 FIRESLEEVE and FSTAPE must be used with RYCO RTH1, SR, SRF, SRX, M2, T5 and RQP5 hose.

Refer to [www.RYCO.com.au](http://www.RYCO.com.au) for current approval certificates & further details.

RYCO HOSE TYPE APPROVALS																
HOSE SERIES	DIEHARD	SLIDER	SURVIVOR	ENERGY	ICEBREAKER	ABS	DNV-GL	LR	MED	USCG	DOT	GOST-R	BV	RINA	KR	MA-KA
<b>BT1</b>	D	S	Sv	E	I											
<b>BT14</b>			•			T2000	T2000	T2000	T2000	T2000		T2000	T2000	T2000	T2000	
<b>BT15</b>			•			T2000	T2000	T2000	T2000	T2000		T2000	T2000	T2000	T2000	
<b>BT16</b>			•			T2000	T2000	T2000	T2000	T2000		T2000	T2000	T2000	T2000	
<b>BT18</b>			•			T2000	T2000	T2000	T2000	T2000		T2000	T2000	T2000	T2000	
<b>BT110</b>			•			T2000	T2000	T2000	T2000	T2000		T2000	T2000	T2000	T2000	
<b>BT112</b>			•			T2000	T2000	T2000	T2000	T2000		T2000	T2000	T2000	T2000	
<b>BT116</b>			•			T2000	T2000	T2000	T2000	T2000		T2000	T2000	T2000	T2000	
<b>*SRF</b>	D	S	Sv	E	I											
<b>SRF12</b>						T4000	T4000	T4000	T4000	T4000		T4000	T4000	T4000	T4000	
<b>SRF16</b>						T4000	T4000	T4000	T4000	T4000		T4000	T4000	T4000	T4000	
<b>SRF20</b>						T4000	T4000	T4000	T4000	T4000		T4000	T4000	T4000	T4000	
<b>SRF24</b>						T4000	T4000	T4000	T4000	T4000		T4000	T4000	T4000	T4000	
<b>SRF32</b>						T4000	T4000	T4000	T4000	T4000		T4000	T4000	T4000	T4000	
<b>*RTH1</b>	D	S	Sv	E	I											
<b>RTH14</b>						TT000	TT000	TT000	TT000	TT000		TT000	TT000	TT000	TT000	
<b>RTH16</b>						TT000	TT000	TT000	TT000	TT000		TT000	TT000	TT000	TT000	
<b>RTH18</b>						TT000	TT000	TT000	TT000	TT000		TT000	TT000	TT000	TT000	
<b>RTH110</b>						TT000	TT000	TT000	TT000	TT000		TT000	TT000	TT000	TT000	
<b>RTH112</b>						TT000	TT000	TT000	TT000	TT000		TT000	TT000	TT000	TT000	
<b>RTH116</b>						TT000	TT000	TT000	TT000	TT000		TT000	TT000	TT000	TT000	
<b>*M2</b>	D	S	Sv	E	I											
<b>M24</b>						T4000	T4000	T4000	T4000	T4000		T4000	T4000	T4000	T4000	
<b>M25</b>						T4000	T4000	T4000	T4000	T4000		T4000	T4000	T4000	T4000	
<b>M26</b>						T4000	T4000	T4000	T4000	T4000		T4000	T4000	T4000	T4000	
<b>M28</b>						T4000	T4000	T4000	T4000	T4000		T4000	T4000	T4000	T4000	
<b>M212</b>						T4000	T4000	T4000	T4000	T4000		T4000	T4000	T4000	T4000	

\* NOTE: For marine application Type Approval compliance, FS1072 FIRESLEEVE and FSTAPE must be used with RYCO RTH1, SR, SRF, SRX, M2, T5 and RQP5 hose.

Refer to [www.RYCO.com.au](http://www.RYCO.com.au) for current approval certificates & further details.

INTRODUCTION

HOSE

COUPLINGS

ADAPTORS

TECHNICAL





# DIEHARD

HOSE THAT WON'T SAY DIE

EXTRA ABRASION RESISTANT

FRAS - FLAME RESISTANT ANTI STATIC

H6000 RYCO DIEHARD™

H6032D 2" -32 DN

RYCO QUALITY

HIGHLY FLEXIBLE



**RYCO**

# SURVIVOR

THE HEAT IS ON

HIGH TEMPERATURE RESISTANCE

MSHA - FLAME RESISTANT

**RYCO SURVIVOR RQP216 1" -16 DN25 MAX WP 167**

RYCO QUALITY

MULTI FLUID



# HOSE COVERS



## RYCO ENERGY

ENERGY AND PERFORMANCE

- **ABRASION RESISTANT**
- **OZONE RESISTANT**
- **STANDARD AND COMPACT HOSE TYPES**

RYCO **ENERGY COMPACT** will ensure the hydraulic system will meet the endurance required to get the job done.

Constructed with two braids of high tensile steel wire, the specially formulated black synthetic cover is oil resistant, and ideally suited for the agricultural market.

RYCO **ENERGY COMPACT** is available in sizes ranging from 1/4" (-04) to 1" (-16) and meets or exceeds the performance requirements of SAE 100R16. RYCO **ENERGY COMPACT** has been designed and manufactured to match with RYCO's T2000 series coupling range.

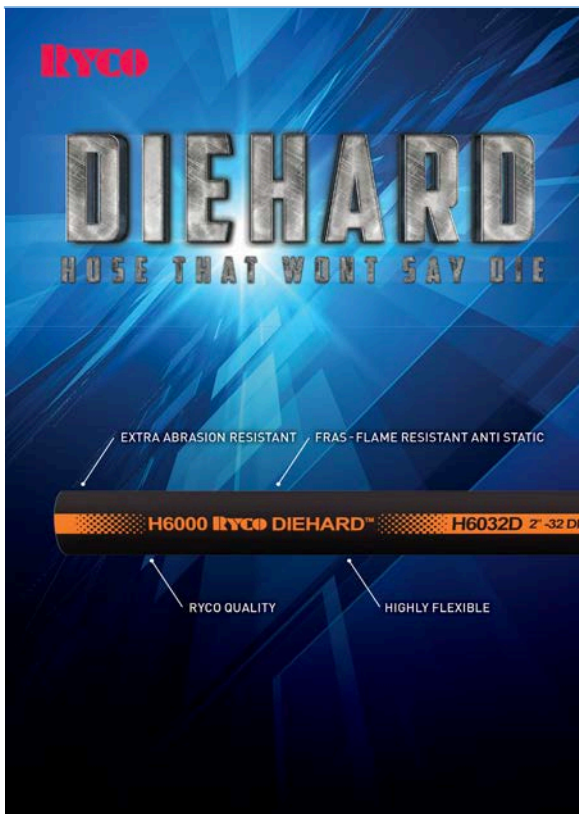

## RYCO DIEHARD™

HOSE THAT WON'T SAY DIE

- **EXTRA ABRASION RESISTANT**
- **MSHA FLAME RESISTANT**
- **FRAS FLAME RESISTANT & ANTI-STATIC**

**DIEHARD™** has a synthetic rubber cover that is extra resistant to abrasion and complies with Flame Resistant and Anti-Static (FRAS) requirements of AS 2660 methods of test AS 1180.10B and AS 1180.13A, also meeting USA MSHA requirements. **DIEHARD™** complies with ISO 6945 method of test for abrasion resistance being less than 10% of the maximum weight loss allowed by EN 853, EN 856 and EN 857.

## HYDRAULIC HOSE COVERS TO SUIT YOUR NEEDS

RYCO Hose styles cover a broad range of hydraulic applications. Different applications require different performance criteria. RYCO ENERGY, DIEHARD™, SLIDER and SURVIVOR™ tube and cover compounds offer a perfect choice and are available across a range of our Hose Styles.

### RYCO SLIDER

GIVE ABRASION THE SLIP

- EXTREMELY ABRASION RESISTANT
- MSHA FLAME RESISTANT

SLIDER has an additional layer of polyethylene protection over the rubber cover of the hose. The result is an extremely abrasion resistant cover that complies with Flame Resistant requirement of AS 2660 method of test AS1180.10B, meeting USA MSHA requirements. SLIDER complies with ISO 6945 method of test for abrasion resistance being less than 0.2% of that allowed by EN 853, EN 856 and EN 857.

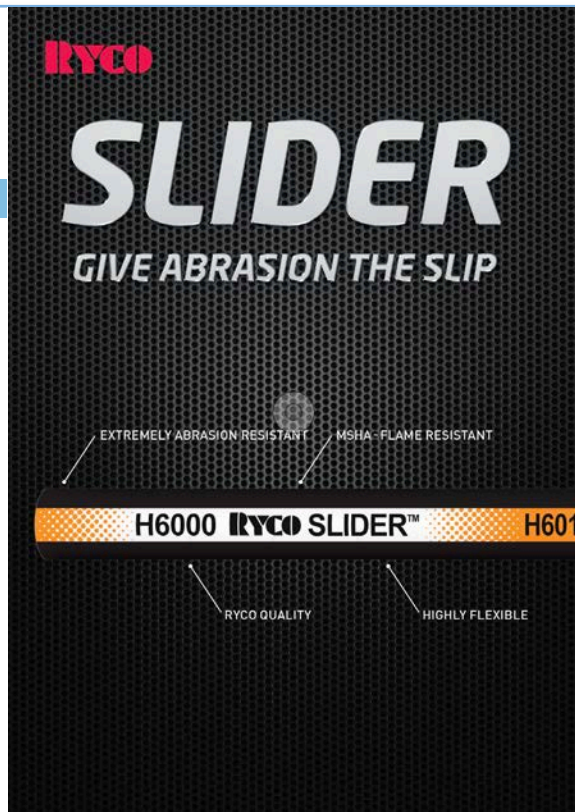

### RYCO SURVIVOR™

THE HEAT IS ON

- HIGH TEMPERATURE (150°C/302°F)
- MSHA FLAME RESISTANT

Designed for high temperature applications and suitable for use with a variety of fluids.

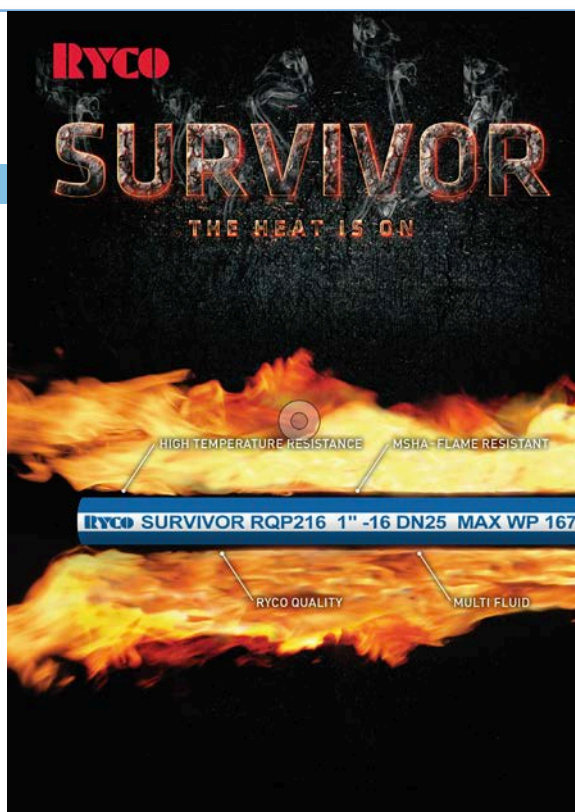





# SLIDER

*GIVE ABRASION THE SLIP*

EXTREMELY ABRASION RESISTANT

MSHA - FLAME RESISTANT

**H6000 RYCO SLIDER™**

**H6016**

RYCO QUALITY

HIGHLY FLEXIBLE

## MAXIMUM WORKING PRESSURES

Maximum Working Pressures shown below (except for **RYCO PL1, PL1D, PL1PV, RQP6** Series) are Dynamic Working Pressures for use with hydraulic fluid in systems with pressure surges or variable loads and are based on 4:1 safety factor (minimum burst to maximum working pressure).

**RYCO PL1, PL1D, PL1PV** and **RQP6** hoses are recommended for use with **RYCO 8000 Series** Push-On Fittings in systems with Static Working Pressures only, and are not recommended for vibration or pressure surge applications. The Maximum Working Pressures for **PL1, PL1D, PL1PV** and **RQP6** shown below are Static Working Pressures.

Hose subjected to both maximum temperature and maximum working pressure will have a shortened lifetime.

HOSE SIZE			T3000D/S	T3600C/D/S	T4000D/S	T5000D/S	T6000D/S	H3000D/S	H4000D/S	H5000C/D/S	H6000D/S	C6000D/S	DF1D	DF2D	DK1D/E/S	DK2D/E/S	EC1	EC2	E1	E2	T1D/S	T1F	T2D/S	T2C	TXA2D	H12D/S
DN	INCH	DASH	BAR																							
3	1/8	-02																								
5	3/16	-03																			250	250				
6	1/4	-04	215	250	280	350	420						225	420	295	450	225	400	225	400	225	225	420	420		
8	5/16	-05	215	250	280	350	420						215	350	250	420	215	350	215	350	215	215	350	350		
10	3/8	-06	215	250	280	350	420		280	350	420		180	350	230	385	180	330	180	330	180	180	350	350		350
12	1/2	-08	215	250	280	350			280	350	420		160	295	200	345	160	275	160	275	160	160	350	350	375	350
16	5/8	-10	215	250	280				280	350	420		130	250	150	290	130	250	130	250	130	130	250	250	350	350
19	3/4	-12	215	250	280				280	350	420	420	105	215	125	280	105	215	105	215	105	105	215	215	315	350
25	1	-16	215	250					280	350	420	420	90	170	110	200	90	165	90	165	90	90	175	175	225	350
31	1.1/4	-20							215	280	350	420		140	100	175					65		140	140		275
38	1.1/2	-24							215	280	350	420									50		100	100		255
51	2	-32							215	280	350	420									40		90	90		210
63	2.1/2	-40																					70			140
76	3	-48																					70			

HOSE SIZE			R4SPD	R4SHD	TJ2D	RQP1	RQP2	RQP5	RQP6	D2B	T5	MS1000	CS1000	BT1	SW	J54000/G/GX/BX	J56000/G/GX/BX	SRF	SRX	RTH1	PL1	PL1D	PL1PV	M1	
DN	INCH	DASH	BAR																						
3	1/8	-02																							
5	3/16	-03																							
6	1/4	-04			700	225	400	210	28		210			50		280	420			170	30	30	30	3,5	
8	5/16	-05				215	350	210	28		210			50		280	420				30	30	30	3,5	
10	3/8	-06	445		700	180	350	157	28		157			50	1250	280	420			165	30	30	30	3,5	
12	1/2	-08	420			160	300	140	28		140	70	70	50	1100	280	420			120	30	30	30		
16	5/8	-10	380			130	250	122	24		122	70	70	50	1000					105	26	26	26		
19	3/4	-12	380	420		105	215	105	21		105	70	70	50	700			21	21	85	22	22	22		
25	1	-16	350	380		90	167	56			56	70	70	50	700					17	17	55			
31	1.1/4	-20		350			150	43		140	43	70	70							14	14				
38	1.1/2	-24		300			100	35		100	35	70	70							11	11				
51	2	-32		250			90	24		90	24	70	70							7	7				
63	2.1/2	-40																							
76	3	-48																		4					

INTRODUCTION

HOSE

COUPLINGS

ADAPTORS

TECHNICAL



## SPECIFICATIONS SUMMARY

### MAXIMUM WORKING PRESSURES (CONT)

HOSE SIZE			MP1	M2	M2G	TP7, TP7N	TP7T, TP7TN	TP8, TP8N	TP8T, TP8TN	TP3000	TPGL
DN	INCH	DASH									
3	1/8	-02									250
5	3/16	-03				210					
6	1/4	-04	13,8	88	2,6	210	210	350	350	210	
8	5/16	-05				190	190				
10	3/8	-06	13,8	78	2,6	160	160	280	280	210	
12	1/2	-08	13,8	70	2,6	140	140	245	245	210	
16	5/8	-10	13,8								
19	3/4	-12	13,8	52	2,6	90					
25	1	-16	13,8			70					
31	1.1/4	-20	13,8								
38	1.1/2	-24									
51	2	-32									
63	2.1/2	-40									
76	3	-48									

#### PRESSURE CONVERSION CHART 1 BAR = 14.5 PSI 1 MPA = 10 BAR

bar	4	7	10	12	14	17	20	24	28	39	55	69	80	90	120	130
psi	58	100	145	175	200	250	300	350	400	565	800	1000	1160	1300	1740	1890
bar	160	180	200	215	225	250	300	337	350	375	400	420	435	500	585	690
psi	2300	2600	2900	3100	3250	3600	4350	4900	5100	5440	5800	6080	6310	7250	8480	10000

The Working Pressure of each Hose Coupling End Termination Style is shown in the Technical section. In most cases, the Working Pressure of the Hose Coupling End Termination Style that can be chosen for a particular hose exceeds the Maximum Working Pressure of the Hose.

It is possible however, to select a Hose Coupling with End Termination with lower Working Pressure than the Hose. In this case, as noted in SAE J516 and SAE J517, the rated Working Pressure of the Hose Assembly must not exceed the lower of the respective Working Pressure rated values.

#### EXAMPLE 1.

T28D Hose Assembly with T2030-0812 coupling one end and T2090-0808 coupling other end.

From above table or from page 101, Maximum Working Pressure of T28D is 350 bar.

From page 201 and the technical section pages 494 to 498 the Maximum Working Pressure of T2030-0812 is 690 bar.

From page 197, and the technical section pages 494 to 498 the Maximum Working Pressure of T2090-0808 is 690 bar.

The Maximum Working Pressure of the Hose Assembly is therefore 350 bar, the lowest of the respective Working Pressure rated values (in this case, the hose).

#### EXAMPLE 2.

H5016D Hose Assembly with T7130-1620 coupling one end and T7030-1621 coupling other end.

From above table or from page 78, Maximum Working Pressure of H5016D is 350 bar.

From page 290 and the technical section pages 494 to 498 the Maximum Working Pressure of T7130-1620 is 280 bar.

From page 278 and the technical section pages 494 to 498 the Maximum Working Pressure of T7030-1621 is 420 bar.

The Maximum Working Pressure of the Hose Assembly is therefore 280 bar, the lowest of the respective Working Pressure rated values (in this case, the T7130-1620).

See page 186 for more information.

## IMPULSE LIFE

Although two or more hoses manufactured to different industry standard specifications may have identical Maximum Working Pressures, their suitability for the application must be considered. An important factor to consider is the magnitude and frequency of the pressure impulses that the hose assembly will experience.

## FLAME RESISTANCE

All RYCO Hoses (except **RYCO JS, T3600C, H5000C, M1, MP1, PW2, TW1, TP7, TP7N, TP7T, TP7TN, TP8, TP8N, TP8T, TP8TN, TP3000, RQP5, SRX, SRF, T5, RTH1 & PL1** Series) meet Flame Resistant Designation "U.S. MSHA" of the U.S. Department of Labor, Mine Safety and Health Administration and also comply with Flame Resistant requirements of Australian Standard AS 2660 and Method of Test AS 1180.10B. Contact RYCO Technical Department for more information.

## MINIMUM BEND RADIUS

Minimum Bend Radius figures published are the radius to the cover of the Hose at the inside of the bend.

RYCO Hose Assemblies exceed the required impulse test requirements when bent to the published Minimum Bend Radius. Hose assemblies bent to smaller than the Minimum Bend Radius will have shortened lifetime.

## ANTI-STATIC

"Anti-Static" refers to Hoses or Hose Assemblies being sufficiently electrically conductive to drain off static electricity.

According to the requirements of AS 2660 Clause 2.2, the Hose or Hose assembly shall have an electrical resistance (measured from inside surface to outside surface) of less than 1 megohm per metre, when tested according to Method of Test AS 1180.13A. For applications requiring Anti-Static Hydraulic Hose Assemblies including, but not limited to, underground coal mines, where there is danger of ignition from static electricity discharge, only special Anti-Static Hose can be used.

RYCO DIEHARD™ Hoses and COALSPRAY comply with the requirements of AS 2660 and Method of Test AS 1180.13A.

## NON CONDUCTIVE

Certain applications require that a Hose, or Hose Assembly, be Non-Conductive to prevent electrical current flow.

For applications that require a Hose to be electrically Non-Conductive including, but not limited to, applications near high voltage electric lines, only special Non-Conductive Hoses can be used.

## SKIVE/NON-SKIVE

Skiving refers to removing the cover at the ends of the Hose where the Hose Couplings are to be attached\*.

Most RYCO combinations of Hose and Couplings are Non-Skive.

In a Non-Skive application, RYCO couplings bite down through the cover and grip the wire reinforcement.

Some combinations of RYCO Hose and Couplings require skiving. If skiving is required, it is clearly stated in both the Hose Section and the Couplings Section.

## OUTSIDE DIAMETERS

See page 151 for reference chart of outside diameters.

## SAFETY GUIDE – MAXIMUM TEMPERATURE LIMITS

Some RYCO Hose Series are not listed on page 58: **T1F, TJ2D, M2G, M1, RTH1, MP1**.

These Hoses are specific purpose Hoses, and their temperature limits are specified in the Hose Section of this Product Technical Manual. Contact RYCO Technical Department for any further queries.

Other RYCO Hose Series are listed on page 58. The Maximum Working Temperatures for these hoses, as listed in the Hose Section of this Product Technical Manual are for use with general purpose, mineral (petroleum) oil based hydraulic fluids, except where otherwise stated. Temperature limits for other hydraulic fluids, and some other common applications, are listed on page 58.

### CAUTION:

Life expectancy of hoses is shortened at high temperatures. Detrimental effects increase when temperature is elevated, and also when; operating pressure, flow velocity, duration and frequency of exposure, and level of impurities in the media are high. Actual service life at temperatures approaching the recommended limits will depend on the particular application and the fluid being used.

Maximum Working Temperatures refer to the temperature of the media in the hose; not the environmental temperature around the outside of the hose. Please contact RYCO Technical Department for environmental temperatures in excess of 80°C (176°F), except **RQP1, RQP2, RQP5** and **RQP6** Series where environmental temperature is the same as media temperature.

Maximum Working Temperatures shown are for continuous temperatures. Slightly higher intermittent temperatures (up to 10% of time) may be acceptable with some hoses and some fluids, if reduced service life is acceptable. Please contact RYCO Technical Department for more information.

DO NOT expose Hose to Maximum Temperature and Maximum Working Pressure at the same time.

The fluid manufacturer's recommended maximum operating temperature for the fluid must not be exceeded. If different to the temperatures listed in the following table, the lower limit must take precedence. We recommend keeping the hose filled with the pressure medium at all times. Further information available on request.



## SPECIFICATIONS SUMMARY

HOSE COVER	GROUP 1	GROUP 2	GROUP 3	GROUP 4	GROUP 5
<b>ENERGY</b>	E1, E2, EC1, EC2, DK1E, DK2E				
<b>DIEHARD</b>	T3000D, T4000D, T5000D, T6000D, T1D, T2D, TXA2D, DF1D, DF2D, DK1D, DK2D, TJ2D, PL1D	H3000D, H4000D, H5000D, H6000D, C6000D, H12D, R4SPD, R4SHD			
<b>SLIDER</b>	T3000S, T4000S, T5000S, T6000S, T1S, T2S, DK1S, DK2S	H3000S, H4000S, H5000S, H6000S, C6000S, H12S			
<b>SURVIVOR</b>	BT1 ***	D2B	RQP1, RQP2		
<b>ICEBREAKER</b>					T3600C, H5000C, T2C
<b>OTHER SERIES</b>	SRF, SRX, M2, T5, T1F, PL1, PL1PV, CS1000, MS1000		RQP5, RQP6	TP7, TP7N, TP7T, TP7TN, TP8, TP8N, TP8T, TP8TN, TP3000, TPGL	

MEDIA	TEMPERATURE LIMITS				
<b>GENERAL PURPOSE MINERAL PETROLEUM BASED HYDRAULIC OIL<sup>1</sup></b>	-40°C to +100°C -40°F to +212°F	-40°C to +121°C -40°F to +250°F	-40°C to +150°C -40°F to +302°F RQP6: -40° to +135°C -40°F to +275°F	-40°C to +95°C -40°F to +203°F	-60°C to +100°C -76°F to +212°F
<b>WATER</b>	0°C to +71°C +32°F to +160°F	0°C to +71°C +32°F to +160°F	0°C to +121°C +32°F to +250°F	0°C to +70°C +32°F to +158°F	0°C to +71°C +32°F to +160°F
<b>WATER IN MINERAL OIL 40% to 80% water</b>	-40°C to +85°C -40°F to +185°F	-40°C to +85°C -40°F to +185°F	-40°C to +121°C -40°F to +250°F	-40°C to +70°C -40°F to +158°F	-60°C to +80°C -60°F to +176°F
<b>MINERAL OIL IN WATER more than 80% water</b>	-40°C to +85°C -40°F to +185°F	-40°C to +85°C -40°F to +185°F	-40°C to +121°C -40°F to +250°F	-40°C to +70°C -40°F to +158°F	-60°C to +80°C -60°F to +176°F
<b>WATER/GLYCOL</b>	-40°C to +85°C -40°F to +185°F	-40°C to +85°C -40°F to +185°F	-40°C to +121°C -40°F to +250°F	-40°C to +70°C -40°F to +158°F	-60°C to +80°C -60°F to +176°F
<b>GLYCOL</b>	-40°C to +85°C -40°F to +185°F	-40°C to +85°C -40°F to +185°F	-40°C to +85°C -40°F to +185°F	-40°C to +70°C -40°F to +158°F	-60°C to +80°C -60°F to +176°F
<b>PHOSPHATE ESTERS</b>	Not suitable	Not suitable	Not suitable	40°C to +70°C -40°F to +158°F see Note 2	Not suitable
<b>AIR<sup>3</sup></b>	-40°C to +71°C (-40°F to +160°F)	-40°C to +71°C -40°F to +160°F see Note 3	-40°C to +121°C -40°F to +250°F RQP6: -40°C to +100°C -40°F to +212°F See note 3	-40°C to +71°C -40°F to +160°F See note 3	-60°C to +71°C -60°F to +160°F
<b>PETROL GASOLINE</b>	Contact RYCO	Contact RYCO	Contact RYCO	Contact RYCO	Contact RYCO
<b>DIESEL FUEL</b>	PL1D: -40°C to +49°C -40°F to +160°F T5: -40°C to +71°C -40°F to +160°F OTHERS: -40°C to +50°C -40°F to +122°F	-40°C to +50°C -40°F to +122°F	RQP1 and RQP2 -40°C to 100°C -40°F to +212°F RQP6: -40°C to +71°C -40°F to +160°F		-60°C to +71°C -60°F to +160°F
<b>ENGINE LUBRICATING OIL, GEARBOX OIL</b>	-40°C to +100°C -40°F to +212°F	-40°C to +100°C -40°F to +212°F	-40°C to +100°C -40°F to +212°F	-40°C to +95°C -40°F to +203°F	-60°C to +80°C -60°F to +176°F
<b>AUTOMATIC TRANSMISSION FLUID</b>	-40°C to +100°C -40°F to +212°F	-40°C to +100°C -40°F to +212°F	-40°C to +100°C -40°F to +212°F	-40°C to +95°C -40°F to +203°F	-60°C to +80°C -60°F to +176°F

1 For highly refined and special purpose mineral based hydraulic oils (for example aviation hydraulic oils, MIL spec oils, etc), contact RYCO Technical Department.

2 Not suitable for use with aerospace type phosphate esters such as Monsanto Skydrol 500B, Stauffer Aero-Safe 2300W and Chevron Hy-jet IV.

3 For use with Air at pressures above 17,2 bar (250 psi), cover of hose must be perforated/pin-pricked (except RQP5 and T5), to allow air permeating through hose to escape without blistering the cover. Maximum working pressure of wire braid and spiral reinforced hose must be reduced by 30% (except for RQP1 and RQP2). Observe all State and Federal Safety Regulations.

# ISOBARIC HOSE

## 1/2 BEND RADIUS

## MILLION CYCLE

### PERFORMANCE AT A GLANCE:

#### H SERIES ISOBARIC SPIRAL HOSE

- Half SAE minimum bend radius.
- Highly flexible for easier routing and installation.
- Isobaric pressure from 215 bar/3100 psi (H3000) to 420 bar/6100 psi (H6000).
- Lighter weight means your hydraulic system is more compact and economical.
- 81 products in the H series Spiral range.
- Includes "World First" H6032 2" (DN51) hose.

#### T SERIES ISOBARIC BRAID HOSE

- Half SAE minimum bend radius.
- Highly flexible for easier routing and installation.
- Isobaric pressure from 215 bar/3100 psi (T3000) to 420 bar/6100 psi (T6000).
- Lighter weight means your hydraulic system is more compact and economical.
- 81 products in the T series Braid hose range.
- T3000 Braid is proven to impulse test of one million cycles in all sizes.
- Meets and exceeds the performance requirements of ISO 18752 (all series).



# WHAT PRESSURE IS YOUR SYSTEM?



215 bar  
3100 psi



250 bar  
3625 psi



280 bar  
4100 psi

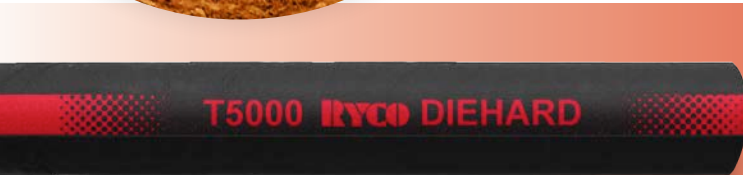

350 bar  
5100 psi



420 bar  
6100 psi



## RYCO MATCHED SYSTEM

RYCO hoses and couplings are designed and engineered to match for maximum safety, leak free performance and exceptional productivity and reliability.

## H SERIES SPIRAL HOSE:



**T6000 SERIES**  
**Non-skive one-piece crimp**  
 For RYCO Hose Series:  
 H5000 sizes -24 to -32.  
 H6000 sizes -12 to -32.



**T7000 SERIES**  
**Non-skive one-piece crimp**  
 For RYCO Hose Series:  
 H3000, H4000 all sizes.  
 H5000 sizes -06 to -24.  
 H6000 sizes -06 to -20.  
 H12D, H12S all sizes.  
 R4SHD sizes -20 to -32  
 D2B sizes -24 to -32

## T SERIES BRAID HOSE:



**T2000 SERIES**  
**Non-skive one-piece crimp**  
 For RYCO Hose Series:  
 T3000, T3600, T4000, T5000 & T6000  
 all sizes.  
 E2 sizes -06 to -16.  
 D2B sizes -20 to -32

## RYCO HOSE COVERS:



**DIEHARD™**

- Extra abrasion resistant
- MSHA flame resistant
- FRAS flame resistant and anti-static

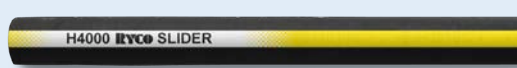

**SLIDER**

- Extremely abrasion resistant
- MSHA flame resistant

## LAYLINE IDENTIFICATION

Colour-coded system enables easy and permanent identification of hoses.

## PRESSURE RANGE / HOSE SERIES:

	420 bar/6100 psi
	350 bar/5100 psi
	280 bar/4100 psi
	250 bar/3625 psi
	215 bar/3100 psi

## COVER TYPE:

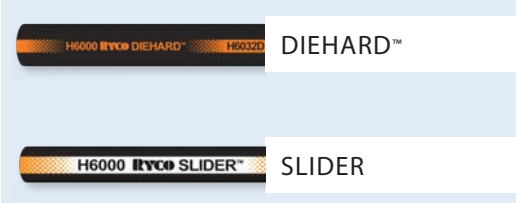

## PART NUMBER:

Incorporates information relating to RYCO hose series, nominal hose size, and cover type in a simple, concise manner.

## SIZE:

The nominal size of the hose is displayed in three commonly used formats (example shown below in appearance of order):

2" (Inch Size)  
 -32 (Dash Size)  
 DN51 (Metric / DN Size)

## WORKING PRESSURE:

RYCO Isobaric range of hose working pressures vary from 215 bar/3100 psi to 420 bar /6100 psi.

## FLAME RESISTANCE:

Flame Resistance and Anti-Static (FRAS) and/or MSHA flame resistance properties of the hose are clearly stated and visible.

H6000 RYCO DIEHARD™

H6032D 2" -32 DN25

MAX WP 420 BAR / 6100 PSI MSHA IC-227/9 FRAS & ABRASION



# HOSE

## ISOBARIC BRAID

### T3000D

EXTRA ABRASION RESISTANT  
FRAS  
COMPACT ISOBARIC HOSE  
215 BAR / 3100 PSI  
MILLION CYCLE



#### RECOMMENDED FOR:

High pressure hydraulic oil lines. Constant pressure (Isobaric) 215 bar / 3100 psi in all sizes. Small bend radius and compact dimensions are advantages in installations.

#### PERFORMANCE:

Meets or Exceeds the Performance Requirements of: ISO 18752-BC, SAE 100R17.

#### TUBE:

Black, oil resistant synthetic rubber.

#### REINFORCEMENT:

One braid (-04 to -08 size) or two braids (-10 to -16 size) of high tensile steel wire.

#### COVER:

**DIEHARD™** Black, oil and extra abrasion resistant synthetic rubber. Flame Resistant, Anti-Static (FRAS) & MSHA compliant. Highly visible layline branding for easy and permanent identification. No skiving required with T2000 Series Crimp Couplings.

#### FEATURES:

Tested to **1 million impulse cycles**. Constant pressure 215 bar / 3100 psi in all sizes for easy system design and hose selection. Small bend radius and compact dimensions are advantages in installations.

#### FRAS - FLAME RESISTANCE AND ANTI-STATIC:

**DIEHARD™** complies with Flame Resistant and Electrical Resistance (Anti-Static) requirements of Australian Standard AS 2660 and Methods of Test AS 1180.10B and 13A. Meets Flame Resistant Designation "U.S. MSHA" of the US Department of Labor, Mine Safety and Health Administration.

#### TEMPERATURE RANGE:

-40°C to +100°C (-40°F to +212°F).  
For water, emulsions etc. see page 58.

#### WORKING PRESSURE:

Maximum working pressures are based on 4:1 safety factor (maximum working pressure to minimum burst pressure).

#### THIRD PARTY APPROVALS:

ABS, DNV-GL, LR, MED, USCG, CLASSNK, GOST-R, BV, RINA and KR.

#### COUPLINGS:

##### NON-SKIVE ONE-PIECE CRIMP

**T2000 Series** (sizes -04 to -16) pages 187 to 232. Assembly Instructions pages 478.

T3000D - DIEHARD COMPACT ISOBARIC HOSE															
PART NO	HOSE SIZE	NOMINAL HOSE ID		NOMINAL HOSE OD		MAXIMUM WORKING PRESSURE		MINIMUM BURST PRESSURE		MINIMUM BEND RADIUS		AVERAGE WEIGHT		COUPLING SERIES ONE PIECE	
Hose	DN	Dash	mm	inch	mm	inch	bar	psi	bar	psi	mm	inch	kg/m	lb/ft	NON-SKIVE
T3004D	6	-04	6,6	1/4	11,8	0.46	245	3500	980	14000	38	1.5	0,16	0.11	T2000
T3005D	8	-05	8,2	5/16	14,4	0.57	245	3500	980	14000	40	1.6	0,23	0.15	T2000
T3006D	10	-06	9,8	3/8	15,6	0.61	215	3100	860	12400	65	2.6	0,26	0.18	T2000
T3008D	12	-08	13,0	1/2	18,7	0.74	215	3100	860	12400	90	3.6	0,36	0.24	T2000
T3010D	16	-10	16,2	5/8	23,4	0.92	215	3100	860	12400	100	3.9	0,56	0.38	T2000
T3012D	19	-12	19,1	3/4	27,6	1.09	215	3100	860	12400	120	4.7	0,78	0.52	T2000
T3016D	25	-16	25,4	1	34,8	1.37	215	3100	860	12400	150	5.9	1,14	0.77	T2000

Refer to the latest RYCO Crimp Charts for crimp diameter and mark lengths,

# T3000S

**EXTREMELY ABRASION RESISTANT**  
MSHA  
**COMPACT ISOBARIC HOSE**  
215 BAR / 3100 PSI  
**MILLION CYCLE**

**RECOMMENDED FOR:**

High pressure hydraulic oil lines. Constant pressure (Isobaric) 215 bar / 3100 psi in all sizes. Small bend radius and compact dimensions are advantages in installations.

**PERFORMANCE:**

Meets or Exceeds the Performance Requirements of: ISO 18752-BC, SAE 100R17.

**TUBE:**

Black, oil resistant synthetic rubber.

**REINFORCEMENT:**

One braid (-04 to -08 size) or two braids (-10 to -16 size) of high tensile steel wire.

**COVER:**

**SLIDER** Black, oil and extremely abrasion resistant synthetic rubber sheathed with a layer of extremely abrasion resistant polyethylene. Flame Resistant, MSHA compliant. Highly visible layline branding for easy and permanent identification. No skiving required with T2000 Series Crimp Couplings.

**FEATURES:**

Tested to **1 million impulse cycles**.

Constant pressure 215 bar / 3100 psi in all sizes for easy system design and hose selection. Small bend radius and compact dimensions are advantages in installations.

**MSHA - FLAME RESISTANCE:**

**SLIDER** complies with Flame Resistant requirements of Australian Standard AS 2660 and Methods of Test AS 1180.10B. Meets Flame Resistant Designation "U.S. MSHA" of the US Department of Labor, Mine Safety and Health Administration.

**TEMPERATURE RANGE:**

-40°C to +100°C (-40°F to +212°F).  
For water, emulsions etc. see page 58.

**WORKING PRESSURE:**

Maximum working pressures are based on 4:1 safety factor (maximum working pressure to minimum burst pressure).

**THIRD PARTY APPROVALS:**

ABS, DNV-GL, LR, MED, USCG, GOST-R, BV, RINA and KR.

**COUPLINGS:**
**NON-SKIVE ONE-PIECE CRIMP**

**T2000 Series** (sizes -04 to -16) pages 187 to 232. Assembly Instructions pages 478.

T3000S - SLIDER COMPACT ISOBARIC HOSE															
PART NO	HOSE SIZE	NOMINAL HOSE ID		NOMINAL HOSE OD		MAXIMUM WORKING PRESSURE		MINIMUM BURST PRESSURE		MINIMUM BEND RADIUS		AVERAGE WEIGHT		COUPLING SERIES ONE PIECE	
Hose	DN	Dash	mm	inch	mm	inch	bar	psi	bar	psi	mm	inch	kg/m	lb/ft	NON-SKIVE
T3004S	6	-04	6,6	1/4	11,8	0.46	245	3500	980	14000	38	1.5	0,16	0.11	T2000
T3005S	8	-05	8,2	5/16	14,4	0.57	245	3500	980	14000	40	1.6	0,23	0.15	T2000
T3006S	10	-06	9,8	3/8	15,6	0.61	215	3100	860	12400	65	2.6	0,26	0.18	T2000
T3008S	12	-08	13,0	1/2	18,7	0.74	215	3100	860	12400	90	3.6	0,36	0.24	T2000
T3010S	16	-10	16,2	5/8	23,4	0.92	215	3100	860	12400	100	3.9	0,56	0.38	T2000
T3012S	19	-12	19,1	3/4	27,6	1.09	215	3100	860	12400	120	4.7	0,78	0.52	T2000
T3016S	25	-16	25,4	1	34,8	1.37	215	3100	860	12400	150	5.9	1,14	0.77	T2000

Refer to the latest RYCO Crimp Charts for crimp diameter and mark lengths.

# HOSE

## ISOBARIC BRAID

### T3600C

LOW TEMPERATURE  
COMPACT ISOBARIC HOSE  
250 BAR / 3625 PSI



#### RECOMMENDED FOR:

High pressure hydraulic oil lines in applications where low temperature environmental conditions exist.

#### PERFORMANCE:

Meets or Exceeds the Performance Requirements of: ISO 18752-BC.

#### TUBE:

Black, specially formulated oil resistant synthetic rubber.

#### REINFORCEMENT:

One braid (-04 to -06 size) or two braids (-08 to -16 size) of high tensile wire.

#### COVER:

Black, oil resistant and abrasion resistant synthetic rubber. No skiving required with T2000 Series Crimp Couplings.

#### FEATURES:

Extremely Flexible. Minimum Bend Radius 25% less than published SAE 100R17 Minimum Bend Radius. Tested to 500,000 cycles. Constant pressure 250 bar / 3625 psi in all sizes for easy system design and hose selection. Small bend radius and compact dimensions are advantages in installations.

#### TEMPERATURE RANGE:

From -60°C to +100°C (-76°F to +212°F).

For water, emulsions etc. see page 58.

#### WORKING PRESSURE:

Maximum working pressures are based on 4:1 safety factor (maximum working pressure to minimum burst pressure).

#### THIRD PARTY APPROVALS:

ABS, DNV-GL, LR, MED, USCG, GOST-R, BV, RINA and KR.

#### COUPLINGS:

##### NON-SKIVE ONE-PIECE CRIMP

**T2000 Series** (sizes -04 to -16) pages 187 to 232. Assembly Instructions pages 478.

T3600D – DIEHARD COMPACT ISOBARIC HOSE															
PART NO	HOSE SIZE	NOMINAL HOSE ID		NOMINAL HOSE OD		MAXIMUM WORKING PRESSURE		MINIMUM BURST PRESSURE		MINIMUM BEND RADIUS		AVERAGE WEIGHT		COUPLING SERIES ONE PIECE	
Hose	DN	Dash	mm	inch	mm	inch	bar	psi	bar	psi	mm	inch	kg/m	lb/ft	NON-SKIVE
T3604C	6	-04	6,6	1/4	11,8	0.46	250	3625	1000	14500	38	1.5	0,16	0.11	T2000
T3605C	8	-05	8,2	5/16	14,4	0.57	250	3625	1000	14500	40	1.6	0,23	0.15	T2000
T3606C	10	-06	9,8	3/8	15,6	0.61	250	3625	1000	14500	49	1.9	0,27	0.18	T2000
T3608C	12	-08	13,0	1/2	19,9	0.78	250	3625	1000	14500	68	2.7	0,45	0.30	T2000
T3610C	16	-10	16,2	5/8	23,4	0.92	250	3625	1000	14500	75	3.0	0,61	0.41	T2000
T3612C	19	-12	19,1	3/4	27,6	1.09	250	3625	1000	14500	90	3.6	0,78	0.52	T2000
T3616C	25	-16	25,4	1	35,2	1.39	250	3625	1000	14500	115	4.5	1,30	0.87	T2000

Refer to the latest RYCO Crimp Charts for crimp diameter and mark lengths.



# T3600D

EXTRA ABRASION RESISTANT  
FRAS  
COMPACT ISOBARIC HOSE  
250 BAR / 3625 PSI

**RECOMMENDED FOR:**

High pressure hydraulic oil lines. Constant pressure (Isobaric) 250 bar / 3625 psi in all sizes. Small bend radius and compact dimensions are advantages in installations.

**PERFORMANCE:**

Meets or Exceeds the Performance Requirements of: ISO 18752-BC.

**TUBE:**

Black, oil resistant synthetic rubber.

**REINFORCEMENT:**

One braid (-04 to -06 size) or two braids (-08 to -16 size) of high tensile wire.

**COVER:**

**DIEHARD™** Black, oil and extra abrasion resistant synthetic rubber. Flame Resistant, Anti-Static (FRAS) & MSHA compliant. Highly visible layline branding for easy and permanent identification. No skiving required with T2000 Series Crimp Couplings.

**FEATURES:**

Extremely Flexible. Minimum Bend Radius 25% less than published SAE 100R17 Minimum Bend Radius. Tested to 500,000 impulse cycles. Constant pressure 250 bar / 3625 psi in all sizes for easy system design and hose selection. Small bend radius and compact dimensions are advantages in installations.

**FRAS - FLAME RESISTANCE AND ANTI-STATIC:**

**DIEHARD™** complies with Flame Resistant and Electrical Resistance (Anti-Static) requirements of Australian Standard AS 2660 and Methods of Test AS 1180.10B and 13A. Meets Flame Resistant Designation "U.S. MSHA" of the US Department of Labor, Mine Safety and Health Administration.

**TEMPERATURE RANGE:**

-40°C to +100°C (-40°F to +212°F).  
For water, emulsions etc. see page 58.

**WORKING PRESSURE:**

Maximum working pressures are based on 4:1 safety factor (maximum working pressure to minimum burst pressure).

**THIRD PARTY APPROVALS:**

ABS, DNV-GL, LR, MED, USCG, GOST-R, BV, RINA and KR.

**COUPLINGS:**
**NON-SKIVE ONE-PIECE CRIMP**

**T2000 Series** (sizes -04 to -16) pages 187 to 232. Assembly Instructions pages 478.

T3600D - DIEHARD COMPACT ISOBARIC HOSE															
PART NO	HOSE SIZE	NOMINAL HOSE ID		NOMINAL HOSE OD		MAXIMUM WORKING PRESSURE		MINIMUM BURST PRESSURE		MINIMUM BEND RADIUS		AVERAGE WEIGHT		COUPLING SERIES ONE PIECE	
Hose	DN	Dash	mm	inch	mm	inch	bar	psi	bar	psi	mm	inch	kg/m	lb/ft	NON-SKIVE
T3604D	6	-04	6,6	1/4	11,8	0.46	250	3625	1000	14500	38	1.5	0,16	0.11	T2000
T3605D	8	-05	8,2	5/16	14,4	0.57	250	3625	1000	14500	40	1.6	0,23	0.15	T2000
T3606D	10	-06	9,8	3/8	15,6	0.61	250	3625	1000	14500	49	1.9	0,27	0.18	T2000
T3608D	12	-08	13,0	1/2	19,9	0.78	250	3625	1000	14500	68	2.7	0,45	0.30	T2000
T3610D	16	-10	16,2	5/8	23,4	0.92	250	3625	1000	14500	75	3.0	0,61	0.41	T2000
T3612D	19	-12	19,1	3/4	27,6	1.09	250	3625	1000	14500	90	3.6	0,78	0.52	T2000
T3616D	25	-16	25,4	1	35,2	1.39	250	3625	1000	14500	115	4.5	1,30	0.87	T2000

Refer to the latest RYCO Crimp Charts for crimp diameter and mark lengths.

# HOSE

## ISOBARIC BRAID

### T3600S

EXTREMELY ABRASION RESISTANT  
COMPACT ISOBARIC HOSE  
250 BAR / 3625 PSI



#### RECOMMENDED FOR:

High pressure hydraulic oil lines. Constant pressure (isobaric) 250 bar / 3625 psi in all sizes. Small bend radius and compact dimensions are advantages in installations.

#### PERFORMANCE:

Meets or Exceeds the Performance Requirements of: ISO 18752-BC.

#### TUBE:

Black, oil resistant synthetic rubber.

#### REINFORCEMENT:

One braid (-04 to -06 size) or two braids (-08 to -16 size) of high tensile wire.

#### COVER:

**SLIDER** Black, oil and extremely abrasion resistant synthetic rubber sheathed with a layer of extremely abrasion resistant polyethylene. Flame Resistant, MSHA compliant. Highly visible layline branding for easy and permanent identification. No skiving required with T2000 Series Crimp Couplings.

#### FEATURES:

Extremely Flexible. Minimum Bend Radius 25% less than published SAE 100R17 Minimum Bend Radius. Tested to 500,000 impulse cycles. Constant pressure 250 bar / 3625 psi in all sizes for easy system design and hose selection. Small bend radius and compact dimensions are advantages in installations.

#### MSHA - FLAME RESISTANCE:

**SLIDER** complies with Flame Resistant requirements of Australian Standard AS 2660 and Methods of Test AS 1180.10B. Meets Flame Resistant Designation "U.S. MSHA" of the US Department of Labor, Mine Safety and Health Administration.

#### TEMPERATURE RANGE:

-40°C to +100°C (-40°F to +212°F).  
For water, emulsions etc. see page 58.

#### WORKING PRESSURE:

Maximum working pressures are based on 4:1 safety factor (maximum working pressure to minimum burst pressure).

#### THIRD PARTY APPROVALS:

ABS, DNV-GL, LR, MED, USCG, GOST-R, BV, RINA and KR.

#### COUPLINGS:

##### NON-SKIVE ONE-PIECE CRIMP

**T2000 Series** (sizes -04 to -16) pages 187 to 232. Assembly Instructions pages 478.

T3600S - SLIDER COMPACT ISOBARIC HOSE															
PART NO	HOSE SIZE	NOMINAL HOSE ID		NOMINAL HOSE OD		MAXIMUM WORKING PRESSURE		MINIMUM BURST PRESSURE		MINIMUM BEND RADIUS		AVERAGE WEIGHT		COUPLING SERIES ONE PIECE	
Hose	DN	Dash	mm	inch	mm	inch	bar	psi	bar	psi	mm	inch	kg/m	lb/ft	NON-SKIVE
T3604S	6	-04	6,6	1/4	11,8	0.46	250	3625	1000	14500	38	1.5	0,16	0.11	T2000
T3605S	8	-05	8,2	5/16	14,4	0.57	250	3625	1000	14500	40	1.6	0,23	0.15	T2000
T3606S	10	-06	9,8	3/8	15,6	0.61	250	3625	1000	14500	49	1.9	0,27	0.18	T2000
T3608S	12	-08	13,0	1/2	19,9	0.78	250	3625	1000	14500	68	2.7	0,45	0.30	T2000
T3610S	16	-10	16,2	5/8	23,4	0.92	250	3625	1000	14500	75	3.0	0,61	0.41	T2000
T3612S	19	-12	19,1	3/4	27,6	1.09	250	3625	1000	14500	90	3.6	0,78	0.52	T2000
T3616S	25	-16	25,4	1	35,2	1.39	250	3625	1000	14500	115	4.5	1,30	0.87	T2000

Refer to the latest RYCO Crimp Charts for crimp diameter and mark lengths.

# T4000D

EXTRA ABRASION RESISTANT  
FRAS  
COMPACT ISOBARIC HOSE  
280 BAR / 4100 PSI

**RECOMMENDED FOR:**

High pressure hydraulic oil lines. Constant pressure (Isobaric) 280 bar / 4100 psi in all sizes. Small bend radius and compact dimensions are advantages in installations.

**PERFORMANCE:**

Meets or Exceeds the Performance Requirements of: ISO 18752-BC, SAE 100R19.

**TUBE:**

Black, oil resistant synthetic rubber.

**REINFORCEMENT:**

One braid (-04 size) or two braids (-05 to -12 size) of high tensile wire.

**COVER:**

**DIEHARD™** Black, oil and extra abrasion resistant synthetic rubber. Flame Resistant, Anti-Static (FRAS) & MSHA compliant. Highly visible layline branding for easy and permanent identification.

**FEATURES:**

Constant pressure 280 bar / 4100 psi in all sizes for easy system design and hose selection. Small bend radius and compact dimensions are advantages in installations.

**FRAS - FLAME RESISTANCE AND ANTI-STATIC:**

**DIEHARD™** complies with Flame Resistant and Electrical Resistance (Anti-Static) requirements of Australian Standard AS 2660 and Methods of Test AS 1180.10B and 13A. Meets Flame Resistant Designation "U.S. MSHA" of the US Department of Labor, Mine Safety and Health Administration.

**TEMPERATURE RANGE:**

-40°C to +100°C (-40°F to +212°F).  
For water, emulsions etc. see page 58.

**WORKING PRESSURE:**

Maximum working pressures are based on 4:1 safety factor (maximum working pressure to minimum burst pressure).

**THIRD PARTY APPROVALS:**

ABS, DNV-GL, LR, MED, USCG, GOST-R, BV, RINA and KR.

**COUPLINGS:**
**NON-SKIVE ONE-PIECE CRIMP**

**T2000 Series** (sizes -04 to -12) pages 187 to 232.  
Assembly Instructions pages 478.

T4000D - DIEHARD COMPACT ISOBARIC HOSE															
PART NO	HOSE SIZE	NOMINAL HOSE ID		NOMINAL HOSE OD		MAXIMUM WORKING PRESSURE		MINIMUM BURST PRESSURE		MINIMUM BEND RADIUS		AVERAGE WEIGHT		COUPLING SERIES ONE PIECE	
Hose	DN	Dash	mm	inch	mm	inch	bar	psi	bar	psi	mm	inch	kg/m	lb/ft	NON-SKIVE
T4004D	6	-04	6,6	1/4	11,8	0.46	280	4100	1120	16400	50	2.0	0,17	0.12	T2000
T4005D	8	-05	8,2	5/16	15,6	0.61	280	4100	1120	16400	55	2.2	0,34	0.23	T2000
T4006D	10	-06	9,8	3/8	16,6	0.65	280	4100	1120	16400	65	2.6	0,37	0.25	T2000
T4008D	12	-08	13,0	1/2	20,6	0.81	280	4100	1120	16400	90	3.6	0,51	0.34	T2000
T4010D	16	-10	16,2	5/8	23,4	0.92	280	4100	1120	16400	100	3.9	0,61	0.41	T2000
T4012D	19	-12	19,1	3/4	28,4	1.12	280	4100	1120	16400	120	4.7	0,92	0.62	T2000

Refer to the latest RYCO Crimp Charts for crimp diameter and mark lengths.



# HOSE

## ISOBARIC BRAID

### T4000S

EXTREMELY ABRASION RESISTANT  
MSHA  
COMPACT ISOBARIC HOSE  
280 BAR / 4100 PSI



#### RECOMMENDED FOR:

High pressure hydraulic oil lines. Constant pressure (Isobaric) 280 bar / 4100 psi in all sizes. Small bend radius and compact dimensions are advantages in installations.

#### PERFORMANCE:

Meets or Exceeds the Performance Requirements of: ISO 18752-BC, SAE 100R19.

#### TUBE:

Black, oil resistant synthetic rubber.

#### REINFORCEMENT:

One braid (-04 size) or two braids (-05 to -12 size) of high tensile wire.

#### COVER:

**SLIDER** Black, oil and extremely abrasion resistant synthetic rubber sheathed with a layer of extremely abrasion resistant polyethylene. Flame Resistant, MSHA compliant. Highly visible layline branding for easy and permanent identification.

#### FEATURES:

Constant pressure 280 bar / 4100 psi in all sizes for easy system design and hose selection. Small bend radius and compact dimensions are advantages in installations.

#### MSHA - FLAME RESISTANCE:

**SLIDER** complies with Flame Resistant requirements of Australian Standard AS 2660 and Methods of Test AS 1180.10B. Meets Flame Resistant Designation "U.S. MSHA" of the US Department of Labor, Mine Safety and Health Administration.

#### TEMPERATURE RANGE:

-40°C to +100°C (-40°F to +212°F).  
For water, emulsions etc. see page 58.

#### WORKING PRESSURE:

Maximum working pressures are based on 4:1 safety factor (maximum working pressure to minimum burst pressure).

#### THIRD PARTY APPROVALS:

ABS, DNV-GL, LR, MED, USCG, GOST-R, BV, RINA and KR.

#### COUPLINGS:

##### NON-SKIVE ONE-PIECE CRIMP

**T2000 Series** (sizes -04 to -12) pages 187 to 232.  
Assembly Instructions pages 478.

T4000S - SLIDER COMPACT ISOBARIC HOSE															
PART NO	HOSE SIZE	NOMINAL HOSE ID		NOMINAL HOSE OD		MAXIMUM WORKING PRESSURE		MINIMUM BURST PRESSURE		MINIMUM BEND RADIUS		AVERAGE WEIGHT		COUPLING SERIES ONE PIECE	
Hose	DN	Dash	mm	inch	mm	inch	bar	psi	bar	psi	mm	inch	kg/m	lb/ft	NON-SKIVE
T4004S	6	-04	6,6	1/4	11,8	0.46	280	4100	1120	16400	50	2.0	0,17	0.12	T2000
T4005S	8	-05	8,2	5/16	15,6	0.61	280	4100	1120	16400	55	2.2	0,34	0.23	T2000
T4006S	10	-06	9,8	3/8	16,6	0.65	280	4100	1120	16400	65	2.6	0,37	0.25	T2000
T4008S	12	-08	13,0	1/2	20,6	0.81	280	4100	1120	16400	90	3.6	0,51	0.34	T2000
T4010S	16	-10	16,2	5/8	23,4	0.92	280	4100	1120	16400	100	3.9	0,61	0.41	T2000
T4012S	19	-12	19,1	3/4	28,4	1.12	280	4100	1120	16400	120	4.7	0,92	0.62	T2000

Refer to the latest RYCO Crimp Charts for crimp diameter and mark lengths.

# T5000D

EXTRA ABRASION RESISTANT  
FRAS  
COMPACT ISOBARIC HOSE  
350 BAR / 5100 PSI

**RECOMMENDED FOR:**

Very high pressure hydraulic oil lines. Constant pressure (isobaric) 350 bar / 5100 psi in all sizes. Small bend radius and compact dimensions are advantages in installations.

**PERFORMANCE:**

Meets or Exceeds the Performance Requirements of: ISO 18752-BC.

**TUBE:**

Black, oil resistant synthetic rubber.

**REINFORCEMENT:**

Two braids of high tensile steel wire.

**COVER:**

**DIEHARD™** Black, oil and extra abrasion resistant synthetic rubber. Flame Resistant, Anti-Static (FRAS) & MSHA compliant. Highly visible layline branding for easy and permanent identification. No skiving required with T2000 Series Crimp Couplings.

**FEATURES:**

Constant pressure 350 bar / 5100 psi in all sizes for easy system design and hose selection. Small bend radius and compact dimensions are advantages in installations.

**FRAS - FLAME RESISTANCE AND ANTI-STATIC:**

**DIEHARD™** complies with Flame Resistant and Electrical Resistance (Anti-Static) requirements of Australian Standard AS 2660 and Methods of Test AS 1180.10B and 13A. Meets Flame Resistant Designation "U.S. MSHA" of the US Department of Labor, Mine Safety and Health Administration.

**TEMPERATURE RANGE:**

-40°C to +100°C (-40°F to +212°F).  
For water, emulsions etc. see page 58.

**WORKING PRESSURE:**

Maximum working pressures are based on 4:1 safety factor (maximum working pressure to minimum burst pressure).

**THIRD PARTY APPROVALS:**

ABS, DNV-GL, LR, MED, USCG, GOST-R, BV, RINA and KR.

**COUPLINGS:**
**NON-SKIVE ONE-PIECE CRIMP**

**T2000 Series** (sizes -04 to -16) pages 187 to 232.  
Assembly Instructions pages 478.

T5000D - DIEHARD COMPACT ISOBARIC HOSE															
PART NO	HOSE SIZE	NOMINAL HOSE ID		NOMINAL HOSE OD		MAXIMUM WORKING PRESSURE		MINIMUM BURST PRESSURE		MINIMUM BEND RADIUS		AVERAGE WEIGHT		COUPLING SERIES ONE PIECE	
Hose	DN	Dash	mm	inch	mm	inch	bar	psi	bar	psi	mm	inch	kg/m	lb/ft	NON-SKIVE
<b>T5004D</b>	6	-04	6,6	1/4	13,2	0.52	350	5100	1400	20400	50	2.0	0,28	0.19	T2000
<b>T5005D</b>	8	-05	8,2	5/16	15,6	0.61	350	5100	1400	20400	55	2.2	0,34	0.23	T2000
<b>T5006D</b>	10	-06	9,8	3/8	17,1	0.67	350	5100	1400	20400	65	2.6	0,41	0.28	T2000
<b>T5008D</b>	12	-08	13,0	1/2	20,6	0.81	350	5100	1400	20400	90	3.6	0,57	0.38	T2000

Refer to the latest RYCO Crimp Charts for crimp diameter and mark lengths.

# HOSE

## ISOBARIC BRAID

### T5000S

EXTREMELY ABRASION RESISTANT  
MSHA  
COMPACT ISOBARIC HOSE  
350 BAR / 5100 PSI



#### RECOMMENDED FOR:

Very high pressure hydraulic oil lines. Constant pressure (Isobaric) 350 bar / 5100 psi in all sizes. Small bend radius and compact dimensions are advantages in installations.

#### PERFORMANCE:

Meets or Exceeds the Performance Requirements of: ISO 18752-BC.

#### TUBE:

Black, oil resistant synthetic rubber.

#### REINFORCEMENT:

Two braids of high tensile steel wire.

#### COVER:

**SLIDER** Black, oil and extremely abrasion resistant synthetic rubber sheathed with a layer of extremely abrasion resistant polyethylene. Flame Resistant, MSHA compliant. Highly visible layline branding for easy and permanent identification. No skiving required with T2000 Series Crimp Couplings.

#### FEATURES:

Constant pressure 350 bar/5100 psi in all sizes for easy system design and hose selection. Small bend radius and compact dimensions are advantages in installations.

#### MSHA - FLAME RESISTANCE:

**SLIDER** complies with Flame Resistant requirements of Australian Standard AS 2660 and Methods of Test AS 1180.10B. Meets Flame Resistant Designation "U.S. MSHA" of the US Department of Labor, Mine Safety and Health Administration.

#### TEMPERATURE RANGE:

-40°C to +100°C (-40°F to +212°F).  
For water, emulsions etc. see page 58.

#### WORKING PRESSURE:

Maximum working pressures are based on 4:1 safety factor (maximum working pressure to minimum burst pressure).

#### THIRD PARTY APPROVALS:

ABS, DNV-GL, LR, MED, USCG, GOST-R, BV, RINA and KR.

#### COUPLINGS:

##### NON-SKIVE ONE-PIECE CRIMP

**T2000 Series** (sizes -04 to -08) pages 187 to 232. Assembly Instructions pages 478.

T5000S - SLIDER COMPACT ISOBARIC HOSE															
PART NO	HOSE SIZE	NOMINAL HOSE ID		NOMINAL HOSE OD		MAXIMUM WORKING PRESSURE		MINIMUM BURST PRESSURE		MINIMUM BEND RADIUS		AVERAGE WEIGHT		COUPLING SERIES ONE PIECE	
Hose	DN	Dash	mm	inch	mm	inch	bar	psi	bar	psi	mm	inch	kg/m	lb/ft	NON-SKIVE
T5004S	6	-04	6,6	1/4	13,2	0.52	350	5100	1400	20400	50	2.0	0,28	0.19	T2000
T5005S	8	-05	8,2	5/16	15,6	0.61	350	5100	1400	20400	55	2.2	0,34	0.23	T2000
T5006S	10	-06	9,8	3/8	17,1	0.67	350	5100	1400	20400	65	2.6	0,41	0.28	T2000
T5008S	12	-08	13,0	1/2	20,6	0.81	350	5100	1400	20400	90	3.6	0,57	0.38	T2000

Refer to the latest RYCO Crimp Charts for crimp diameter and mark lengths.



# T6000D

EXTRA ABRASION RESISTANT  
FRAS  
COMPACT ISOBARIC HOSE  
420 BAR / 6100 PSI



### RECOMMENDED FOR:

Extremely high pressure hydraulic oil lines. Constant pressure (Isobaric) 420 bar / 6100 psi in all sizes. Small bend radius and compact dimensions are advantages in installations.

### PERFORMANCE:

Meets or Exceeds the Performance Requirements of: ISO 18752-BC.

### TUBE:

Black, oil resistant synthetic rubber.

### REINFORCEMENT:

Two braids of high tensile steel wire.

### COVER:

**DIEHARD™** Black, oil and extra abrasion resistant synthetic rubber. Flame Resistant, Anti-Static (FRAS) & MSHA compliant. Highly visible layline branding for easy and permanent identification. No skiving required with T2000 Series Crimp Couplings.

### FEATURES:

Constant pressure 420 bar / 6100 psi in all sizes for easy system design and hose selection. Small bend radius and compact dimensions are advantages in installations.

### FRAS - FLAME RESISTANCE AND ANTI-STATIC:

**DIEHARD™** complies with Flame Resistant and Electrical Resistance (Anti-Static) requirements of Australian Standard AS 2660 and Methods of Test AS 1180.10B and 13A. Meets Flame Resistant Designation "U.S. MSHA" of the US Department of Labor, Mine Safety and Health Administration.

### TEMPERATURE RANGE:

-40°C to +100°C (-40°F to +212°F).  
For water, emulsions etc. see page 58.

### WORKING PRESSURE:

Maximum working pressures are based on 4:1 safety factor (maximum working pressure to minimum burst pressure).

### THIRD PARTY APPROVALS:

ABS, DNV-GL, LR, MED, USCG, GOST-R, BV, RINA and KR.

### COUPLINGS:

#### NON-SKIVE ONE-PIECE CRIMP

**T2000 Series** (sizes -04 to -06) pages 187 to 232.  
Assembly Instructions pages 478.

T6000D - DIEHARD COMPACT ISOBARIC HOSE															
PART NO	HOSE SIZE	NOMINAL HOSE ID		NOMINAL HOSE OD		MAXIMUM WORKING PRESSURE		MINIMUM BURST PRESSURE		MINIMUM BEND RADIUS		AVERAGE WEIGHT		COUPLING SERIES ONE PIECE	
Hose	DN	Dash	mm	inch	mm	inch	bar	psi	bar	psi	mm	inch	kg/m	lb/ft	NON-SKIVE
T6004D	6	-04	6,6	1/4	13,2	0.52	420	6100	1680	24400	50	2.0	0,28	0.19	T2000
T6005D	8	-05	8,2	5/16	15,6	0.61	420	6100	1680	24400	55	2.2	0,35	0.24	T2000
T6006D	10	-06	9,8	3/8	17,6	0.69	420	6100	1680	24400	65	2.6	0,47	0.32	T2000

Refer to the latest RYCO Crimp Charts for crimp diameter and mark lengths.

# HOSE

## ISOBARIC BRAID

### T6000S

EXTREMELY ABRASION RESISTANT  
MSHA  
COMPACT ISOBARIC HOSE  
420 BAR / 6100 PSI



#### RECOMMENDED FOR:

Extremely high pressure hydraulic oil lines. Constant pressure (Isobaric) 420 bar / 6100 psi in all sizes. Small bend radius and compact dimensions are advantages in installations.

#### PERFORMANCE:

Meets or Exceeds the Performance Requirements of: ISO 18752-BC.

#### TUBE:

Black, oil resistant synthetic rubber.

#### REINFORCEMENT:

Two braids of high tensile steel wire.

#### COVER:

**SLIDER** Black, oil and extremely abrasion resistant synthetic rubber sheathed with a layer of extremely abrasion resistant polyethylene. Flame Resistant, MSHA compliant. Highly visible layline branding for easy and permanent identification. No skiving required with T2000 Series Crimp Couplings.

#### FEATURES:

Constant pressure 420 bar / 6100 psi in all sizes for easy system design and hose selection. Small bend radius and compact dimensions are advantages in installations.

#### MSHA - FLAME RESISTANCE:

**SLIDER** complies with Flame Resistant requirements of Australian Standard AS 2660 and Methods of Test AS 1180.10B. Meets Flame Resistant Designation "U.S. MSHA" of the US Department of Labor, Mine Safety and Health Administration.

#### TEMPERATURE RANGE:

-40°C to +100°C (-40°F to +212°F).  
For water, emulsions etc. see page 58.

#### WORKING PRESSURE:

Maximum working pressures are based on 4:1 safety factor (maximum working pressure to minimum burst pressure).

#### THIRD PARTY APPROVALS:

ABS, DNV-GL, LR, MED, USCG, GOST-R, BV, RINA and KR.

#### COUPLINGS:

##### NON-SKIVE ONE-PIECE CRIMP

**T2000 Series** (sizes -04 to -06) pages 187 to 232. Assembly Instructions pages 478.

T6000S - SLIDER COMPACT ISOBARIC HOSE															
PART NO	HOSE SIZE	NOMINAL HOSE ID		NOMINAL HOSE OD		MAXIMUM WORKING PRESSURE		MINIMUM BURST PRESSURE		MINIMUM BEND RADIUS		AVERAGE WEIGHT		COUPLING SERIES	
		mm	inch	mm	inch	bar	psi	bar	psi	mm	inch	kg/m	lb/ft	ONE PIECE	
<b>T6004S</b>	6	-04	6,6	1/4	13,2	0,52	420	6100	1680	24400	50	2.0	0,28	0.19	T2000
<b>T6005S</b>	8	-05	8,2	5/16	15,6	0,61	420	6100	1680	24400	55	2.2	0,35	0.24	T2000
<b>T6006S</b>	10	-06	9,8	3/8	17,6	0,69	420	6100	1680	24400	65	2.6	0,47	0.32	T2000

Refer to the latest RYCO Crimp Charts for crimp diameter and mark lengths.

# H3000D

EXTRA ABRASION RESISTANT  
FRAS  
ISOBARIC SPIRAL HOSE  
215 BAR / 3100 PSI  
MILLION CYCLE



INTRODUCTION

HOSE

COUPLINGS

ADAPTORS

TECHNICAL

### RECOMMENDED FOR:

High pressure hydraulic oil lines. Constant pressure (Isobaric) 215 bar / 3100 psi in all sizes. Small bend radius is an advantage in installations.

### PERFORMANCE:

Meets or Exceeds the Performance Requirements of:  
EN 856 Type R12, EN 856 Type 4SP, ISO 18752-DC,  
SAE 100R12.

### TUBE:

Black, oil resistant synthetic rubber.

### REINFORCEMENT:

Four alternating layers of spiralled high tensile steel wire.

### COVER:

**DIEHARD™** Black, oil and extra abrasion resistant synthetic rubber. Flame Resistant, Anti-Static (FRAS) & MSHA compliant. Highly visible layline branding for easy and permanent identification. No skiving required with T7000 Series Crimp Couplings.

### FEATURES:

Tested to **1 million impulse cycles** at up to 1/2 SAE 100R12 Minimum Bend Radius. Constant pressure 215 bar / 3100 psi in all sizes for easy system design and hose selection. Small bend radius is an advantage in installations.

### FRAS - FLAME RESISTANCE AND ANTI-STATIC:

**DIEHARD™** complies with Flame Resistant and Electrical Resistance (Anti-Static) requirements of Australian Standard AS 2660 and Methods of Test AS 1180.10B and 13A. Meets Flame Resistant Designation "U.S. MSHA" of the US Department of Labor, Mine Safety and Health Administration.

### TEMPERATURE RANGE:

-40°C to +121°C (-40°F to +250°F).  
For water, emulsions etc. see page 58.

### WORKING PRESSURE:

Maximum working pressures are based on 4:1 safety factor (maximum working pressure to minimum burst pressure).

### THIRD PARTY APPROVALS:

ABS, DNV-GL, LR, MED, USCG, GOST-R, BV, RINA and KR.

### COUPLINGS:

#### NON-SKIVE ONE-PIECE CRIMP

**T7000 Series** (sizes -20 to -32) pages 187 to 232.  
Assembly Instructions pages 478.

H3000D - DIEHARD ISOBARIC SPIRAL HOSE															
PART NO	HOSE SIZE	NOMINAL HOSE ID		NOMINAL HOSE OD		MAXIMUM WORKING PRESSURE		MINIMUM BURST PRESSURE		MINIMUM BEND RADIUS		AVERAGE WEIGHT		COUPLING SERIES ONE PIECE	
Hose	DN	Dash	mm	inch	mm	inch	bar	psi	bar	psi	mm	inch	kg/m	lb/ft	NON-SKIVE
H3020D	31	-20	31,8	1.1/4	45,7	1.80	215	3100	860	12400	200	7.9	2,27	1.53	T7000
H3024D	38	-24	38,1	1.1/2	50,3	1.98	215	3100	860	12400	250	9.8	2,35	1.58	T7000
H3032D	51	-32	50,8	2	63,3	2.49	215	3100	860	12400	400	15.8	3,40	2.28	T7000

Refer to the latest RYCO Crimp Charts for crimp diameter and mark lengths.

# HOSE

## ISOBARIC SPIRAL

### H3000S

**EXTREMELY ABRASION RESISTANT**  
**MSHA**  
**ISOBARIC SPIRAL HOSE**  
**215 BAR / 3100 PSI**  
**MILLION CYCLE**



**RECOMMENDED FOR:**

High pressure hydraulic oil lines. Constant pressure (Isobaric) 215 bar / 3100 psi in all sizes. Small bend radius is an advantage in installations.

**PERFORMANCE:**

Meets or Exceeds the Performance Requirements of: EN 856 Type R12, EN 856 Type 4SP, ISO 18752-DC, SAE 100R12.

**TUBE:**

Black, oil resistant synthetic rubber.

**REINFORCEMENT:**

Four alternating layers of spiralled high tensile steel wire.

**COVER:**

**SLIDER** Black, oil and extremely abrasion resistant synthetic rubber sheathed with a layer of extremely abrasion resistant polyethylene. Flame Resistant, MSHA compliant. Highly visible layline branding for easy and permanent identification. No skiving required with T7000 Series Crimp Couplings.

**FEATURES:**

Tested to **1 million impulse cycles** at up to 1/2 SAE 100R12 Minimum Bend Radius. Constant pressure 215 bar / 3100 psi in all sizes for easy system design and hose selection. Small bend radius is an advantage in installations.

**MSHA - FLAME RESISTANCE:**

**SLIDER** complies with Flame Resistant requirements of Australian Standard AS 2660 and Methods of Test AS 1180.10B. Meets Flame Resistant Designation "U.S. MSHA" of the US Department of Labor, Mine Safety and Health Administration.

**TEMPERATURE RANGE:**

-40°C to +121°C (-40°F to +250°F).  
 For water, emulsions etc. see page 58.

**WORKING PRESSURE:**

Maximum working pressures are based on 4:1 safety factor (maximum working pressure to minimum burst pressure).

**THIRD PARTY APPROVALS:**

ABS, DNV-GL, LR, MED, USCG, GOST-R, BV, RINA and KR.

**COUPLINGS:**

**NON-SKIVE ONE-PIECE CRIMP**

**T7000 Series** (sizes -20 to -32) pages 272 to 302. Assembly Instructions pages 478.

H3000S – SLIDER ISOBARIC SPIRAL HOSE															
PART NO	HOSE SIZE	NOMINAL HOSE ID		NOMINAL HOSE OD		MAXIMUM WORKING PRESSURE		MINIMUM BURST PRESSURE		MINIMUM BEND RADIUS		AVERAGE WEIGHT		COUPLING SERIES ONE PIECE	
Hose	DN	Dash	mm	inch	mm	inch	bar	psi	bar	psi	mm	inch	kg/m	lb/ft	NON-SKIVE
H3020S	31	-20	31,8	1.1/4	45,7	1.80	215	3100	860	12400	200	7.9	2,27	1.53	T7000
H3024S	38	-24	38,1	1.1/2	50,3	1.98	215	3100	860	12400	250	9.8	2,35	1.58	T7000
H3032S	51	-32	50,8	2	63,3	2.49	215	3100	860	12400	400	15.8	3,40	2.28	T7000

Refer to the latest RYCO Crimp Charts for crimp diameter and mark lengths.



# H4000D

EXTRA ABRASION RESISTANT  
FRAS  
ISOBARIC SPIRAL HOSE  
280 BAR / 4100 PSI  
MILLION CYCLE



INTRODUCTION

## RECOMMENDED FOR:

High pressure hydraulic oil lines. Constant pressure (Isobaric) 280 bar / 4100 psi in all sizes. Small bend radius is an advantage in installations.

## PERFORMANCE:

Meets or Exceeds the Performance Requirements of:  
EN 856 Type R12, EN 856 Type 4SP (size DN25, -16),  
ISO 18752-DC, SAE 100R12.

## TUBE:

Black, oil resistant synthetic rubber.

## REINFORCEMENT:

Four (-06 to -24 size) and six (-32 size) alternating layers of spiralled high tensile steel wire.

## COVER:

**DIEHARD™** Black, oil and extra abrasion resistant synthetic rubber. Flame Resistant, Anti-Static (FRAS) & MSHA compliant. Highly visible layline branding for easy and permanent identification. No skiving required with T7000 Series Crimp Couplings.

## FEATURES:

Tested to **1 million impulse cycles** at up to 1/2 SAE 100R12 Minimum Bend Radius. Constant pressure 280 bar / 4100 psi in all sizes for easy system design and hose selection. Small bend radius is an advantage in installations.

## FRAS - FLAME RESISTANCE AND ANTI-STATIC:

**DIEHARD™** complies with Flame Resistant and Electrical Resistance (Anti-Static) requirements of Australian Standard AS 2660 and Methods of Test AS 1180.10B and 13A. Meets Flame Resistant Designation "U.S. MSHA" of the US Department of Labor, Mine Safety and Health Administration.

## TEMPERATURE RANGE:

-40°C to +121°C, (-40°F to +250°F.)  
For water, emulsions etc. see page 58.

## WORKING PRESSURE:

Maximum working pressures are based on 4:1 safety factor (maximum working pressure to minimum burst pressure).

## THIRD PARTY APPROVALS:

ABS, DNV-GL, LR, MED, USCG, GOST-R, BV, RINA and KR.

## COUPLINGS:

### NON-SKIVE ONE-PIECE CRIMP

**T7000 Series** (sizes -06 to -32) pages 272 to 302. Assembly Instructions pages 478.

HOSE

COUPLINGS

ADAPTORS

TECHNICAL

H4000D - DIEHARD ISOBARIC SPIRAL HOSE															
PART NO	HOSE SIZE	NOMINAL HOSE ID		NOMINAL HOSE OD		MAXIMUM WORKING PRESSURE		MINIMUM BURST PRESSURE		MINIMUM BEND RADIUS		AVERAGE WEIGHT		COUPLING SERIES ONE PIECE	
Hose	DN	Dash	mm	inch	mm	inch	bar	psi	bar	psi	mm	inch	kg/m	lb/ft	NON-SKIVE
H4006D	10	-06	9,5	3/8	19,3	0.76	280	4100	1120	16400	60	2.4	0,61	0.41	T7000
H4008D	12	-08	12,7	1/2	22,7	0.89	280	4100	1120	16400	90	3.5	0,78	0.52	T7000
H4010D	16	-10	15,9	5/8	24,9	0.98	280	4100	1120	16400	100	3.9	0,76	0.51	T7000
H4012D	19	-12	19,1	3/4	30,0	1.18	280	4100	1120	16400	120	4.7	1,13	0.76	T7000
H4016D	25	-16	25,4	1	36,9	1.45	280	4100	1120	16400	150	5.9	1,60	1.08	T7000
H4020D	31	-20	31,8	1.1/4	44,0	1.73	280	4100	1120	16400	210	8.3	2,07	1.39	T7000
H4024D	38	-24	38,1	1.1/2	50,8	2.00	280	4100	1120	16400	330	13.0	2,65	1.78	T7000
H4032D	51	-32	50,8	2	66,4	2.61	280	4100	1120	16400	400	15.8	4,73	3.18	T7000

Refer to the latest RYCO Crimp Charts for crimp diameter and mark lengths.

# HOSE

## ISOBARIC SPIRAL

### H4000S

EXTREMELY ABRASION RESISTANT  
MSHA

ISOBARIC SPIRAL HOSE

280 BAR / 4100 PSI

MILLION CYCLE



#### RECOMMENDED FOR:

High pressure hydraulic oil lines. Constant pressure (Isobaric) 280 bar / 4100 psi in all sizes. Small bend radius is an advantage in installations.

#### PERFORMANCE:

Meets or Exceeds the Performance Requirements of: EN 856 Type R12, EN 856 Type 4SP (size DN25, -16), ISO 18752-DC, SAE 100R12.

#### TUBE:

Black, oil resistant synthetic rubber.

#### REINFORCEMENT:

Four (-06 to -24 size) and six (-32 size) alternating layers of spiralled high tensile steel wire.

#### COVER:

**SLIDER** Black, oil and extremely abrasion resistant synthetic rubber sheathed with a layer of extremely abrasion resistant polyethylene. Flame Resistant, MSHA compliant. Highly visible layline branding for easy and permanent identification. No skiving required with T7000 Series Crimp Couplings.

#### FEATURES:

Tested to **1 million impulse cycles** at up to 1/2 SAE 100R12 Minimum Bend Radius. Constant pressure 280 bar / 4100 psi in all sizes for easy system design and hose selection. Small bend radius is an advantage in installations.

#### MSHA - FLAME RESISTANCE:

**SLIDER** complies with Flame Resistant requirements of Australian Standard AS 2660 and Methods of Test AS 1180.10B. Meets Flame Resistant Designation "U.S. MSHA" of the US Department of Labor, Mine Safety and Health Administration.

#### TEMPERATURE RANGE:

-40°C to +121°C, (-40°F to +250°F.)  
For water, emulsions etc. see page 58.

#### WORKING PRESSURE:

Maximum working pressures are based on 4:1 safety factor (maximum working pressure to minimum burst pressure).

#### THIRD PARTY APPROVALS:

ABS, DNV-GL, LR, MED, USCG, GOST-R, BV, RINA and KR.

#### COUPLINGS:

##### NON-SKIVE ONE-PIECE CRIMP

**T7000 Series** (sizes -06 to -32) pages 272 to 302. Assembly Instructions pages 478.

H4000S - SLIDER ISOBARIC SPIRAL HOSE															
PART NO	HOSE SIZE	NOMINAL HOSE ID		NOMINAL HOSE OD		MAXIMUM WORKING PRESSURE		MINIMUM BURST PRESSURE		MINIMUM BEND RADIUS		AVERAGE WEIGHT		COUPLING SERIES ONE PIECE	
Hose	DN	Dash	mm	inch	mm	inch	bar	psi	bar	psi	mm	inch	kg/m	lb/ft	NON-SKIVE
H4006S	10	-06	9,5	3/8	19,3	0.76	280	4100	1120	16400	60	2.4	0,61	0.41	T7000
H4008S	12	-08	12,7	1/2	22,7	0.89	280	4100	1120	16400	90	3.5	0,78	0.52	T7000
H4010S	16	-10	15,9	5/8	24,9	0.98	280	4100	1120	16400	100	3.9	0,76	0.51	T7000
H4012S	19	-12	19,1	3/4	30,0	1.18	280	4100	1120	16400	120	4.7	1,13	0.76	T7000
H4016S	25	-16	25,4	1	36,9	1.45	280	4100	1120	16400	150	5.9	1,60	1.08	T7000
H4020S	31	-20	31,8	1.1/4	44,0	1.73	280	4100	1120	16400	210	8.3	2,07	1.39	T7000
H4024S	38	-24	38,1	1.1/2	50,8	2.00	280	4100	1120	16400	330	13.0	2,65	1.78	T7000
H4032S	51	-32	50,8	2	66,4	2.61	280	4100	1120	16400	400	15.8	4,73	3.18	T7000

Refer to the latest RYCO Crimp Charts for crimp diameter and mark lengths.

# H5000C

LOW TEMPERATURE  
ISOBARIC SPIRAL HOSE  
350 BAR / 5100 PSI



INTRODUCTION

HOSE

COUPLINGS

ADAPTORS

TECHNICAL

### RECOMMENDED FOR:

Very high pressure hydraulic oil lines in application where low temperature environmental conditions exist. Constant pressure (Isobaric) 350 bar / 5100 psi in all sizes. Small bend radius is an advantage in installations.

### PERFORMANCE:

Meets or Exceeds the Performance Requirements of: EN 856 Type R13, ISO 18752-CC, SAE100R13.

### TUBE:

Black, oil resistant synthetic rubber.

### REINFORCEMENT:

Four (-12 to -20 size) and six (-32 size) alternating layers of spiralled high tensile steel wire.

### COVER:

Black, oil and abrasion resistant synthetic rubber.

### FEATURES:

Low temperature hose (-60°C/-76°F). Constant pressure 350 bar / 5100 psi in all sizes for easy system design and hose selection.

Small bend radius is an advantage in installations.

### TEMPERATURE RANGE:

-60°C to +100°C (-76°F to +212°F).

### WORKING PRESSURE:

Maximum working pressures are based on 4:1 safety factor (maximum working pressure to minimum burst pressure).

### THIRD PARTY APPROVALS:

ABS, DNV-GL, LR, MED, USCG, GOST-R, BV, RINA and KR.

### COUPLINGS:

#### NON-SKIVE ONE-PIECE CRIMP

**T7000 Series** (sizes -12 to -20) pages 272 to 302.  
Assembly Instructions pages 478.

H5000C - ICEBREAKER ISOBARIC SPIRAL HOSE															
PART NO	HOSE SIZE	NOMINAL HOSE ID		NOMINAL HOSE OD		MAXIMUM WORKING PRESSURE		MINIMUM BURST PRESSURE		MINIMUM BEND RADIUS		AVERAGE WEIGHT		COUPLING SERIES ONE PIECE	
Hose	DN	Dash	mm	inch	mm	inch	bar	psi	bar	psi	mm	inch	kg/m	lb/ft	NON-SKIVE
H5012C	19	-12	19,1	3/4	29,6	1.17	350	5100	1400	20400	120	4.7	1,21	0.81	T7000
H5016C	25	-16	25,4	1	36,8	1.45	350	5100	1400	20400	150	5.9	1,72	1.16	T7000
H5020C	31	-20	31,8	1.1/4	45,0	1.77	350	5100	1400	20400	210	8.3	2,42	1.63	T7000
H5024C	38	-24	38,1	1.1/2	52,7	2.07	350	5100	1400	20400	330	13	3,44	2.31	T7000

Refer to the latest RYCO Crimp Charts for crimp diameter and mark lengths.

# HOSE

## ISOBARIC SPIRAL

### H5000D

EXTRA ABRASION RESISTANT  
FRAS

ISOBARIC SPIRAL HOSE

350 BAR / 5100 PSI

MILLION CYCLE



#### RECOMMENDED FOR:

Very high pressure hydraulic oil lines. Constant pressure (Isobaric) 350 bar / 5100 psi in all sizes. Small bend radius is an advantage in installations.

#### PERFORMANCE:

Meets or Exceeds the Performance Requirements of: EN 856 Type R13, ISO 18752-CC, SAE 100R13.

#### TUBE:

Black, oil resistant synthetic rubber.

#### REINFORCEMENT:

Four (-06 to -20 size) and six (-24 to -32 size) alternating layers of spiralled high tensile steel wire.

#### COVER:

**DIEHARD™** Black, oil and extra abrasion resistant synthetic rubber. Flame Resistant, Anti-Static (FRAS) & MSHA compliant. Highly visible layline branding for easy and permanent identification. No skiving required with T6000 & T7000 Series Crimp Couplings.

#### FEATURES:

Tested to **1 million impulse cycles** at up to 1/2 SAE 100R13 Minimum Bend Radius. Constant pressure 350 bar / 5100 psi in all sizes for easy system design and hose selection. Small bend radius is an advantage in installations.

#### FRAS - FLAME RESISTANCE AND ANTI-STATIC:

**DIEHARD™** complies with Flame Resistant and Electrical Resistance (Anti-Static) requirements of Australian Standard AS 2660 and Methods of Test AS 1180.10B and 13A. Meets Flame Resistant Designation "U.S. MSHA" of the US Department of Labor, Mine Safety and Health Administration.

#### TEMPERATURE RANGE:

-40°C to +121°C, (-40°F to +250°F.)  
For water, emulsions etc. see page 58.

#### WORKING PRESSURE:

Maximum working pressures are based on 4:1 safety factor (maximum working pressure to minimum burst pressure).

#### THIRD PARTY APPROVALS:

ABS, DNV-GL, LR, MED, USCG, GOST-R, BV, RINA and KR.

#### COUPLINGS:

##### NON-SKIVE ONE-PIECE CRIMP

**T7000 Series** (sizes -06 to -24) pages 272 to 302.

**T6000 Series** (size -12 to -32) pages 250 to 270.

Assembly Instructions pages 478.

H5000D - DIEHARD ISOBARIC SPIRAL HOSE															
PART NO	HOSE SIZE	NOMINAL HOSE ID		NOMINAL HOSE OD		MAXIMUM WORKING PRESSURE		MINIMUM BURST PRESSURE		MINIMUM BEND RADIUS		AVERAGE WEIGHT		COUPLING SERIES ONE PIECE	
Hose	DN	Dash	mm	inch	mm	inch	bar	psi	bar	psi	mm	inch	kg/m	lb/ft	NON-SKIVE
H5006D	10	-06	9,5	3/8	19,3	0.76	350	5100	1400	20400	60	2.4	0,61	0.41	T7000
H5008D	12	-08	12,7	1/2	22,7	0.89	350	5100	1400	20400	90	3.5	0,78	0.52	T7000
H5010D	16	-10	15,9	5/8	26,2	1.03	350	5100	1400	20400	100	3.9	0,98	0.66	T7000
H5012D	19	-12	19,1	3/4	29,6	1.17	350	5100	1400	20400	120	4.7	1,21	0.81	T6000 T7000
H5016D	25	-16	25,4	1	36,8	1.45	350	5100	1400	20400	150	5.9	1,72	1.16	T6000 T7000
H5020D	31	-20	31,8	1.1/4	45,0	1.77	350	5100	1400	20400	210	8.3	2,42	1.63	T6000 T7000
H5024D	38	-24	38,1	1.1/2	52,7	2.07	350	5100	1400	20400	330	13.0	3,44	2.31	T6000 T7000
H5032D	51	-32	50,8	2	67,5	2.66	350	5100	1400	20400	400	15.8	5,40	3.63	T6000

Refer to the latest RYCO Crimp Charts for crimp diameter and mark lengths.



# H5000S

EXTREMELY ABRASION RESISTANT

MSHA

ISOBARIC SPIRAL HOSE

350 BAR / 5100 PSI

MILLION CYCLE



INTRODUCTION

HOSE

COUPLINGS

ADAPTORS

TECHNICAL

## RECOMMENDED FOR:

Very high pressure hydraulic oil lines. Constant pressure (isobaric) 350 bar / 5100 psi in all sizes. Small bend radius is an advantage in installations.

## PERFORMANCE:

Meets or Exceeds the Performance Requirements of: EN 856 Type R13, ISO 18752-CC, SAE 100R13.

## TUBE:

Black, oil resistant synthetic rubber.

## REINFORCEMENT:

Four (-06 to -20 size) and six (-24 to -32 size) alternating layers of spiralled high tensile steel wire.

## COVER:

**SLIDER** Black, oil and extremely abrasion resistant synthetic rubber sheathed with a layer of extremely abrasion resistant polyethylene. Flame Resistant, MSHA compliant. Highly visible layline branding for easy and permanent identification. No skiving required with T6000 & T7000 Series Crimp Couplings.

## FEATURES:

Tested to **1 million impulse cycles** at up to 1/2 SAE 100R13 Minimum Bend Radius. Constant pressure 350 bar / 5100 psi in all sizes for easy system design and hose selection. Small bend radius is an advantage in installations.

## MSHA - FLAME RESISTANCE:

**SLIDER** complies with Flame Resistant requirements of Australian Standard AS 2660 and Methods of Test AS 1180.10B. Meets Flame Resistant Designation "U.S. MSHA" of the US Department of Labor, Mine Safety and Health Administration.

## TEMPERATURE RANGE:

-40°C to +121°C, (-40°F to +250°F)  
For water, emulsions etc. see page 58.

## WORKING PRESSURE:

Maximum working pressures are based on 4:1 safety factor (maximum working pressure to minimum burst pressure).

## THIRD PARTY APPROVALS:

ABS, DNV-GL, LR, MED, USCG, GOST-R, BV, RINA and KR.

## COUPLINGS:

### NON-SKIVE ONE-PIECE CRIMP

**T7000 Series** (sizes -06 to -24) pages 272 to 302.

**T6000 Series** (size -12 to -32) pages 250 to 270. Assembly Instructions pages 478.

H5000S - SLIDER ISOBARIC SPIRAL HOSE															
PART NO	HOSE SIZE	NOMINAL HOSE ID		NOMINAL HOSE OD		MAXIMUM WORKING PRESSURE		MINIMUM BURST PRESSURE		MINIMUM BEND RADIUS		AVERAGE WEIGHT		COUPLING SERIES ONE PIECE	
Hose	DN	Dash	mm	inch	mm	inch	bar	psi	bar	psi	mm	inch	kg/m	lb/ft	NON-SKIVE
H5006S	10	-06	9,5	3/8	19,3	0.76	350	5100	1400	20400	60	2.4	0,61	0.41	T7000
H5008S	12	-08	12,7	1/2	22,7	0.89	350	5100	1400	20400	90	3.5	0,78	0.52	T7000
H5010S	16	-10	15,9	5/8	26,2	1.03	350	5100	1400	20400	100	3.9	0,98	0.66	T7000
H5012S	19	-12	19,1	3/4	29,6	1.17	350	5100	1400	20400	120	4.7	1,21	0.81	T6000 T7000
H5016S	25	-16	25,4	1	36,8	1.45	350	5100	1400	20400	150	5.9	1,72	1.16	T6000 T7000
H5020S	31	-20	31,8	1.1/4	45,0	1.77	350	5100	1400	20400	210	8.3	2,42	1.63	T6000 T7000
H5024S	38	-24	38,1	1.1/2	52,7	2.07	350	5100	1400	20400	330	13.0	3,44	2.31	T6000 T7000
H5032S	51	-32	50,8	2	67,5	2.66	350	5100	1400	20400	400	15.8	5,40	3.63	T6000

Refer to the latest RYCO Crimp Charts for crimp diameter and mark lengths.

# HOSE

## ISOBARIC SPIRAL

### H6000D

EXTRA ABRASION RESISTANT  
FRAS

ISOBARIC SPIRAL HOSE

420 BAR / 6100 PSI

MILLION CYCLE



#### RECOMMENDED FOR:

Extremely high pressure hydraulic oil lines. Constant pressure (Isobaric) 420 bar / 6100 psi in all sizes. Small bend radius is an advantage in installations.

#### PERFORMANCE:

Meets or Exceeds the Performance Requirements of: EN 856 Type R15, ISO 18752-CC, SAE 100R15.

#### TUBE:

Black, oil resistant synthetic rubber.

#### REINFORCEMENT:

Four (-06 to -16 size), six (-20 to -24 size) and eight (-32 size) alternating layers of spiralled high tensile steel wire.

#### COVER:

**DIEHARD™** Black, oil and extra abrasion resistant synthetic rubber. Flame Resistant, Anti-Static (FRAS) & MSHA compliant. Highly visible layline branding for easy and permanent identification. No skiving required with T6000 and T7000 Series Crimp Couplings.

#### FEATURES:

Tested to **1 million impulse cycles** at up to 1/2 SAE 100R15 Minimum Bend Radius. **World First:** World's first 2" (-32) hose tested to 1 million impulse cycles at 400mm (15.8") Minimum Bend Radius. Constant pressure 420 bar / 6100 psi in all sizes for easy system design and hose selection. Small bend radius is an advantage in installations.

#### FRAS - FLAME RESISTANCE AND ANTI-STATIC:

**DIEHARD™** complies with Flame Resistant and Electrical Resistance (Anti-Static) requirements of Australian Standard AS 2660 and Methods of Test AS 1180.10B and 13A.

Meets Flame Resistant Designation "U.S. MSHA" of the US Department of Labor, Mine Safety and Health Administration.

#### TEMPERATURE RANGE:

-40°C to +121°C (-40°F to +250°F).

For water, emulsions etc. see page 58.

#### WORKING PRESSURE:

Maximum working pressures are based on 4:1 safety factor (maximum working pressure to minimum burst pressure).

#### THIRD PARTY APPROVALS:

ABS, DNV-GL, LR, MED, USCG, GOST-R, BV, RINA and KR.

#### COUPLINGS:

##### NON-SKIVE ONE-PIECE CRIMP

**T7000 Series** (sizes -06 to -20) pages 272 to 302.

**T6000 Series** (size -12 to -32) pages 250 to 270.

Assembly Instructions pages 478.

H6000D - DIEHARD ISOBARIC SPIRAL HOSE															
PART NO	HOSE SIZE	NOMINAL HOSE ID		NOMINAL HOSE OD		MAXIMUM WORKING PRESSURE		MINIMUM BURST PRESSURE		MINIMUM BEND RADIUS		AVERAGE WEIGHT		COUPLING SERIES ONE PIECE	
Hose	DN	Dash	mm	inch	mm	inch	bar	psi	bar	psi	mm	inch	kg/m	lb/ft	NON-SKIVE
H6006D	10	-06	9,5	3/8	19,3	0.76	420	6100	1680	24400	75	2.9	0,61	0.41	T7000
H6008D	12	-08	12,7	1/2	22,7	0.89	420	6100	1680	24400	100	3.9	0,78	0.52	T7000
H6010D	16	-10	15,9	5/8	26,2	1.03	420	6100	1680	24400	110	4.3	1,00	0.67	T7000
H6012D	19	-12	19,1	3/4	30,6	1.20	420	6100	1680	24400	115	4.5	1,38	0.93	T6000 T7000
H6016D	25	-16	25,4	1	37,5	1.48	420	6100	1680	24400	165	6.5	1,99	1.34	T6000 T7000
H6020D	31	-20	31,8	1.1/4	46,4	1.83	420	6100	1680	24400	220	8.7	2,97	2.00	T6000 T7000
H6024D	38	-24	38,1	1.1/2	53,1	2.09	420	6100	1680	24400	350	13.8	3,81	2.56	T6000
H6032D	51	-32	50,8	2	71,5	2.81	420	6100	1680	24400	400	15.8	7,10	4.77	T6000

Refer to the latest RYCO Crimp Charts for crimp diameter and mark lengths.

# H6000S

EXTREMELY ABRASION RESISTANT

MSHA

ISOBARIC SPIRAL HOSE

420 BAR / 6100 PSI

MILLION CYCLE



INTRODUCTION

HOSE

COUPLINGS

ADAPTORS

TECHNICAL

## RECOMMENDED FOR:

Extremely high pressure hydraulic oil lines. Constant pressure (Isobaric) 420 bar / 6100 psi in all sizes. Small bend radius is an advantage in installations.

## PERFORMANCE:

Meets or Exceeds the Performance Requirements of: ISO 3862 Type R15, ISO 18752-CC, SAE 100R15.

## TUBE:

Black, oil resistant synthetic rubber.

## REINFORCEMENT:

Four (-06 to -16 size), six (-20 to -24 size) and eight (-32 size) alternating layers of spiralled high tensile steel wire.

## COVER:

**SLIDER** Black, oil and extremely abrasion resistant synthetic rubber sheathed with a layer of extremely abrasion resistant polyethylene. Flame Resistant, MSHA compliant. Highly visible layline branding for easy and permanent identification. No skiving required with T6000 and T7000 Series Crimp Couplings.

## FEATURES:

Tested to **1 million impulse cycles** at up to 1/2 SAE 100R15 Minimum Bend Radius. **World First:** World's first 2" (-32) hose tested to 1 million impulse cycles at 400mm (15.8") Minimum Bend Radius. Constant pressure 420 bar / 6100 psi in all sizes for easy system design and hose selection. Small bend radius is an advantage in installations.

## MSHA - FLAME RESISTANCE:

**SLIDER** complies with Flame Resistant requirements of Australian Standard AS 2660 and Methods of Test AS 1180.10B. Meets Flame Resistant Designation "U.S. MSHA" of the US Department of Labor, Mine Safety and Health Administration.

## TEMPERATURE RANGE:

-40°C to +121°C (-40°F to +250°F).  
For water, emulsions etc. see page 58.

## WORKING PRESSURE:

Maximum working pressures are based on 4:1 safety factor (maximum working pressure to minimum burst pressure).

## THIRD PARTY APPROVALS:

ABS, DNV-GL, LR, MED, USCG, GOST-R, BV, RINA and KR.

## COUPLINGS:

### NON-SKIVE ONE-PIECE CRIMP

**T7000 Series** (sizes -06 to -20) pages 272 to 302.

**T6000 Series** (size -12 to -32) pages 250 to 270.

Assembly Instructions pages 478.

H6000S - SLIDER ISOBARIC SPIRAL HOSE															
PART NO	HOSE SIZE	NOMINAL HOSE ID		NOMINAL HOSE OD		MAXIMUM WORKING PRESSURE		MINIMUM BURST PRESSURE		MINIMUM BEND RADIUS		AVERAGE WEIGHT		COUPLING SERIES ONE PIECE	
Hose	DN	Dash	mm	inch	mm	inch	bar	psi	bar	psi	mm	inch	kg/m	lb/ft	NON-SKIVE
H6006S	10	-06	9,5	3/8	19,3	0.76	420	6100	1680	24400	75	2.9	0,61	0.41	T7000
H6008S	12	-08	12,7	1/2	22,7	0.89	420	6100	1680	24400	100	3.9	0,78	0.52	T7000
H6010S	16	-10	15,9	5/8	26,2	1.03	420	6100	1680	24400	110	4.3	1,00	0.67	T7000
H6012S	19	-12	19,1	3/4	30,6	1.20	420	6100	1680	24400	115	4.5	1,38	0.93	T6000 T7000
H6016S	25	-16	25,4	1	37,5	1.48	420	6100	1680	24400	165	6.5	1,99	1.34	T6000 T7000
H6020S	31	-20	31,8	1.1/4	46,4	1.83	420	6100	1680	24400	220	8.7	2,97	2.00	T6000 T7000
H6024S	38	-24	38,1	1.1/2	53,1	2.09	420	6100	1680	24400	350	13.8	3,81	2.56	T6000
H6032S	51	-32	50,8	2	71,5	2.81	420	6100	1680	24400	400	15.8	7,10	4.77	T6000

Refer to the latest RYCO Crimp Charts for crimp diameter and mark lengths.

# HOSE

## ISOBARIC SPIRAL

### C6000D

ULTRA FLEXIBLE  
EXTRA ABRASION RESISTANT  
FRAS  
ISOBARIC SPIRAL HOSE  
420 BAR / 6100 PSI  
MILLION CYCLE



#### RECOMMENDED FOR:

Ultra flexibility and small bend radius provides easy installation in compact environments.  
Extremely high pressure hydraulic oil lines.  
Constant pressure (Isobaric) 420 bar / 6100 psi in all sizes.

#### PERFORMANCE:

Meets or Exceeds the Performance Requirements of:  
ISO 18752-CC, SAE 100R15.

#### TUBE:

Black, oil resistant synthetic rubber.

#### REINFORCEMENT:

Four alternating layers of spiralled high tensile steel wire.

#### COVER:

**DIEHARD™** Black, oil and extra abrasion resistant synthetic rubber. Flame Resistant, Anti-Static (FRAS) & MSHA compliant. Highly visible layline branding for easy and permanent identification. No skiving required with T7000 Series Crimp Couplings.

#### FEATURES:

Ultra flexibility combined with a small bend radius reduces effort during assembly and installations. Tested to **1 million impulse cycles** at up to 1/2 SAE 100R15 Minimum Bend Radius. Constant pressure 420 bar / 6100 psi in all sizes for easy system design and hose selection.

#### FRAS - FLAME RESISTANCE AND ANTI-STATIC:

**DIEHARD™** complies with Flame Resistant and Electrical Resistance (Anti-Static) requirements of Australian Standard AS 2660 and Methods of Test AS 1180.10B and 13A. Meets Flame Resistant Designation "U.S. MSHA" of the US Department of Labor, Mine Safety and Health Administration.

#### TEMPERATURE RANGE:

-40°C to +121°C (-40°F to +250°F).

#### WORKING PRESSURE:

Maximum working pressures are based on 4:1 safety factor (maximum working pressure to minimum burst pressure).

#### COUPLINGS:

##### NON-SKIVE ONE-PIECE CRIMP

**T7000 Series** (sizes -12 to -16) pages 272 to 302.  
Assembly Instructions pages 478.

C6000D - DIEHARD ULTRA FLEXIBLE ISOBARIC SPIRAL HOSE															
PART NO	HOSE SIZE	NOMINAL HOSE ID		NOMINAL HOSE OD		MAXIMUM WORKING PRESSURE		MINIMUM BURST PRESSURE		MINIMUM BEND RADIUS		AVERAGE WEIGHT		COUPLING SERIES	
Hose	DN	Dash	mm	inch	mm	inch	bar	psi	bar	psi	mm	inch	kg/m	lb/ft	NON-SKIVE
C6012D	19	-12	19,1	3/4	28,5	1.12	420	6100	1680	24400	115	4.5	1,15	0.77	T7000
C6016D	25	-16	25,4	1	35,8	1.41	420	6100	1680	24400	165	6.5	1,75	1.17	T7000

Refer to the latest RYCO Crimp Charts for crimp diameter and mark lengths.



# C6000S

ULTRA FLEXIBLE  
EXTREMELY ABRASION RESISTANT  
ISOBARIC SPIRAL HOSE  
420 BAR / 6100 PSI  
MILLION CYCLE



INTRODUCTION

HOSE

COUPLINGS

ADAPTORS

TECHNICAL

### RECOMMENDED FOR:

Ultra flexibility and small bend radius provides easy installation in compact environments.  
Extremely high pressure hydraulic oil lines.  
Constant pressure (Isobaric) 420 bar / 6100 psi in all sizes.

### PERFORMANCE:

Meets or Exceeds the Performance Requirements of:  
ISO 18752-CC, SAE 100R15.

### TUBE:

Black, oil resistant synthetic rubber.

### REINFORCEMENT:

Four alternating layers of spiralled high tensile steel wire.

### COVER:

**SLIDER** Black, oil and extremely abrasion resistant synthetic rubber sheathed with a layer of extremely abrasion resistant polyethylene. Flame Resistant, MSHA compliant. Highly visible layline branding for easy and permanent identification. No skiving required with T7000 Series Crimp Couplings.

### FEATURES:

Ultra flexibility combined with a small bend radius reduces effort during assembly and installations. Tested to **1 million impulse cycles** at up to 1/2 SAE 100R15 Minimum Bend Radius. Constant pressure 420 bar / 6100 psi in all sizes for easy system design and hose selection.

### MSHA - FLAME RESISTANCE:

**SLIDER** complies with Flame Resistant requirements of Australian Standard AS 2660 and Methods of Test AS 1180.10B. Meets Flame Resistant Designation "U.S. MSHA" of the US Department of Labor, Mine Safety and Health Administration.

### TEMPERATURE RANGE:

-40°C to +121°C (-40°F to +250°F).

### WORKING PRESSURE:

Maximum working pressures are based on 4:1 safety factor (maximum working pressure to minimum burst pressure).

### COUPLINGS:

#### NON-SKIVE ONE-PIECE CRIMP

**T7000 Series** (sizes -12 to -16) pages 272 to 302.  
Assembly Instructions pages 478.

C6000S - SLIDER ULTRA FLEXIBLE ISOBARIC SPIRAL HOSE														COUPLING SERIES	
PART NO	HOSE SIZE	NOMINAL HOSE ID		NOMINAL HOSE OD		MAXIMUM WORKING PRESSURE		MINIMUM BURST PRESSURE		MINIMUM BEND RADIUS		AVERAGE WEIGHT		ONE PIECE	
Hose	DN	Dash	mm	inch	mm	inch	bar	psi	bar	psi	mm	inch	kg/m	lb/ft	NON-SKIVE
C6012S	19	-12	19,1	3/4	28,5	1.12	420	6100	1680	24400	115	4.5	1,15	0.77	T7000
C6016S	25	-16	25,4	1	35,8	1.41	4.20	6100	1680	24400	165	6.5	1,75	1.17	T7000

Refer to the latest RYCO Crimp Charts for crimp diameter and mark lengths.

# HOSE

## BRAID

### DF1D

EXTRA ABRASION RESISTANT  
FRAS  
COMPACT HOSE  
ONE WIRE BRAID



**RECOMMENDED FOR:**

High pressure hydraulic oil lines in applications where the outside cover of the hose is subjected to abrasion that may cause premature failure of standard hoses.

**PERFORMANCE:**

Meets or Exceeds the Performance Requirements of: EN 857 Type 1SC, ISO 11237 Type 1SC.

**TUBE:**

Black, oil resistant synthetic rubber.

**REINFORCEMENT:**

One braid of high tensile steel wire.

**COVER:**

**DIEHARD™** Black, oil and extra abrasion resistant synthetic rubber. Flame Resistant, Anti-Static (FRAS) & MSHA compliant. Highly visible layline branding for easy and permanent identification. No skiving required with T2000 Series Crimp Couplings.

**FEATURES:**

The very high abrasion resistant properties of the cover, combined with the high working pressures and excellent impulse life, results in increased service life and minimises equipment downtime.

**FRAS - FLAME RESISTANCE AND ANTI-STATIC:**

DIEHARD™ complies with Flame Resistant and Electrical Resistance (Anti-Static) requirements of Australian Standard AS 2660 and Methods of Test AS 1180.10B and 13A. Meets Flame Resistant Designation "U.S MSHA" of the US Department of Labour, Mine Safety and Health Administration.

**TEMPERATURE RANGE:**

From -40°C to +100°C (-40°F to +212°F).

**WORKING PRESSURE:**

Maximum working pressures are based on 4:1 safety factor (maximum working pressure to minimum burst pressure).

**THIRD PARTY APPROVALS:**

ABS, DNV-GL, LR, MED, USCG, GOST-R, BV, RINA and KR.

**COUPLINGS:**

**NON-SKIVE ONE-PIECE CRIMP**

**T2000 Series** (sizes -04 to -16) pages 187 to 232. Assembly Instructions pages 478.

Not suitable for use with field attachable couplings.

DF1D - DINFLEX NON-SKIVE HOSE															
PART NO	HOSE SIZE	NOMINAL HOSE ID		NOMINAL HOSE OD		MAXIMUM WORKING PRESSURE		MINIMUM BURST PRESSURE		MINIMUM BEND RADIUS		AVERAGE WEIGHT		COUPLING SERIES ONE PIECE	
Hose	DN	Dash	mm	inch	mm	inch	bar	psi	bar	psi	mm	inch	kg/m	lb/ft	NON-SKIVE
DF14D	6	-04	6,6	1/4	12,2	0.48	225	3250	900	13000	50	2.0	0,20	0.13	T2000
DF15D	8	-05	8,2	5/16	13,9	0.55	215	3100	860	12400	55	2.2	0,22	0.15	T2000
DF16D	10	-06	9,8	3/8	15,6	0.61	180	2600	720	10400	65	2.6	0,26	0.17	T2000
DF18D	12	-08	13,0	1/2	19,0	0.75	160	2300	640	9200	85	3.3	0,33	0.22	T2000
DF110D	16	-10	16,2	5/8	22,2	0.80	130	1900	520	7600	100	3.9	0,44	0.30	T2000
DF112D	19	-12	19,1	3/4	25,6	1.01	105	1500	420	6000	115	4.5	0,50	0.34	T2000
DF116D	25	-16	25,4	1	33,6	1.32	90	1280	360	5120	150	5.9	0,75	0.50	T2000

Refer to the latest RYCO Crimp Charts for crimp diameter and mark lengths.

# DF2D

EXTRA ABRASION RESISTANT  
FRAS  
COMPACT HOSE  
TWO WIRE BRAID

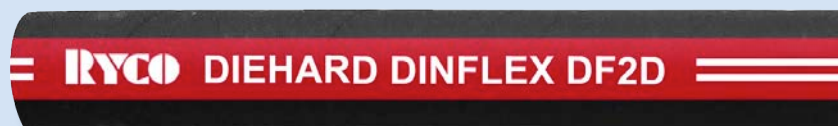

### RECOMMENDED FOR:

High pressure hydraulic oil lines in applications where the outside cover of the hose is subjected to abrasion that may cause premature failure of standard hoses. Ideal for high pressure use that requires a compact outside diameter and smaller bend radius than some other two wire braid hoses.

### PERFORMANCE:

Meets or Exceeds the Performance Requirements of:  
EN 857 Type 2SC, ISO 11237 Type 2SC, SAE 100R16.  
(-20 size SAE 100R16 only).

### TUBE:

Black, oil resistant synthetic rubber.

### REINFORCEMENT:

Two braids of high tensile steel wire.

### COVER:

**DIEHARD™** Black, oil and extra abrasion resistant synthetic rubber. Flame Resistant, Anti-Static (FRAS) & MSHA compliant. Highly visible layline branding for easy and permanent identification. No skiving required with T2000 Series Crimp Couplings.

### FEATURES:

The very high abrasion resistant properties of the cover, combined with the high working pressures and excellent impulse life, results in increased service life and minimises equipment downtime.

### FRAS - FLAME RESISTANCE AND ANTI-STATIC:

DIEHARD™ complies with Flame Resistant and Electrical Resistance (Anti-Static) requirements of Australian Standard AS 2660 and Methods of Test AS 1180.10B and 13A. Meets Flame Resistant Designation "U.S MSHA" of the US Department of Labour, Mine Safety and Health Administration.

### TEMPERATURE RANGE:

From -40°C to +100°C (-40°F to +212°F).

### WORKING PRESSURE:

Maximum working pressures are based on 4:1 safety factor (maximum working pressure to minimum burst pressure).

### THIRD PARTY APPROVALS:

ABS, DNV-GL, LR, MED, USCG, GOST-R, BV, RINA and KR.

### COUPLINGS:

#### NON-SKIVE ONE-PIECE CRIMP

**T2000 Series** (sizes -04 to -20) pages 187 to 232.  
Assembly Instructions pages 478.

Not suitable for use with field attachable couplings.

INTRODUCTION

HOSE

COUPLINGS

ADAPTORS

TECHNICAL

DF2D - DINFLEX NON-SKIVE HOSE															
PART NO	HOSE SIZE	NOMINAL HOSE ID		NOMINAL HOSE OD		MAXIMUM WORKING PRESSURE		MINIMUM BURST PRESSURE		MINIMUM BEND RADIUS		AVERAGE WEIGHT		COUPLING SERIES ONE PIECE	
Hose	DN	Dash	mm	inch	mm	inch	bar	psi	bar	psi	mm	inch	kg/m	lb/ft	NON-SKIVE
DF24D	6	-04	6,6	1/4	13,4	0.53	420	6100	1680	24000	50	2.0	0,28	0.19	T2000
DF25D	8	-05	8,2	5/16	14,9	0.59	350	5100	1400	20400	55	2.2	0,41	0.27	T2000
DF26D	10	-06	9,8	3/8	17,3	0.68	350	5100	1400	20400	65	2.6	0,43	0.29	T2000
DF28D	12	-08	13,0	1/2	20,3	0.80	295	4250	1180	17000	90	3.6	0,51	0.34	T2000
DF210D	16	-10	16,2	5/8	23,6	0.93	250	3625	1000	14500	100	3.9	0,63	0.42	T2000
DF212D	19	-12	19,1	3/4	27,6	1.09	215	3100	860	12400	120	4.7	0,81	0.55	T2000
DF216D	25	-16	25,4	1	35,8	1.40	170	2400	668	9700	150	5.9	1,10	0.74	T2000
DF220D	31	-20	31,8	1.1/4	41,3	1.63	140	2000	560	8000	150	5.9	1,39	0.93	T2000

Refer to the latest RYCO Crimp Charts for crimp diameter and mark lengths.

\* DF220D Minimum Bend Radius is smaller than that of SAE 100R16 by approximately 30%

# HOSE

## BRAID

### DK1D

EXTRA ABRASION RESISTANT  
EXTRA HIGH PRESSURE  
FRAS  
COMPACT ONE WIRE BRAID HOSE



#### RECOMMENDED FOR:

Extra high pressure hydraulic oil lines in applications where the hose cover is subjected to abrasion. Compact dimensions and small bend radius are advantages in installations where space is limited.

#### PERFORMANCE:

Exceeds the Performance Requirements of: EN 857 Type 1SC, ISO 11237 Type 1SC.

#### CONSTRUCTION:

RYCO Proprietary DK1D design.

#### TUBE:

Black, oil resistant synthetic rubber.

#### REINFORCEMENT:

One braid of high tensile steel wire.

#### COVER:

**DIEHARD™** Black, oil, ozone and extra abrasion resistant synthetic rubber. Flame Resistant, Anti-Static (FRAS) & MSHA compliant. Highly visible layline branding for easy and permanent identification. No skiving required with T2000 Series Crimp Couplings.

#### FEATURES:

The very high abrasion resistant properties of the cover, combined with the extra high working pressures and excellent impulse life, results in increased service life and minimises equipment downtime. Compact dimensions and small bend radius are advantages in installations where space is limited.

#### FRAS - FLAME RESISTANCE AND ANTI-STATIC:

DIEHARD™ complies with Flame Resistant and Electrical Resistance (Anti-Static) requirements of Australian Standard AS 2660 and Methods of Test AS 1180.10B and 13A, and requirements of ISO 6805 when tested in accordance with ISO 8030 and ISO 8031. Meets Flame Resistant Designation "U.S. MSHA" of the US Department of Labour, Mine Safety and Health Administration.

#### TEMPERATURE RANGE:

From -40°C to +100°C (-40°F to +212°F).

#### WORKING PRESSURE:

Maximum working pressures are based on 4:1 safety factor (maximum working pressure to minimum burst pressure).

#### COUPLINGS:

##### NON-SKIVE ONE-PIECE CRIMP

**T2000 Series** (sizes -04 to -16) pages 187 to 232. Assembly Instructions pages 478.

Not suitable for use with field attachable couplings.

DK1D - COMPACT EXTRA HIGH PRESSURE NON-SKIVE HOSE															
PART NO	HOSE SIZE	NOMINAL HOSE ID		NOMINAL HOSE OD		MAXIMUM WORKING PRESSURE		MINIMUM BURST PRESSURE		MINIMUM BEND RADIUS		AVERAGE WEIGHT		COUPLING SERIES ONE PIECE	
Hose	DN	Dash	mm	inch	mm	inch	bar	psi	bar	psi	mm	inch	kg/m	lb/ft	NON-SKIVE
DK14D	6	-04	6,6	1/4	11,6	0.46	295	4280	1180	17120	40	1.6	0,16	0.11	T2000
DK15D	8	-05	8,5	5/16	13,4	0.53	250	3625	1000	14500	50	2.0	0,20	0.13	T2000
DK16D	10	-06	9,8	3/8	15,0	0.59	230	3340	920	13360	65	2.6	0,24	0.16	T2000
DK18D	12	-08	13,0	1/2	18,3	0.72	200	2900	800	11600	80	3.1	0,31	0.21	T2000
DK110D	16	-10	16,1	5/8	21,5	0.85	150	2175	600	8700	100	3,9	0,38	0.26	T2000
DK112D	19	-12	19,1	3/4	24,7	0.97	125	1815	500	7260	120	4.7	0,44	0.30	T2000
DK116D	25	-16	25,4	1	31,6	1.24	110	1600	440	6400	150	5,9	0,61	0.41	T2000
DK120D	31	-20	31,8	1.1/4	38,4	1.51	100	1450	400	5800	200	7.9	0,79	0.53	T2000

Refer to the latest RYCO Crimp Charts for crimp diameter and mark lengths.



# DK1E

EXTRA HIGH PRESSURE  
COMPACT ONE WIRE BRAID HOSE



INTRODUCTION

HOSE

COUPLINGS

ADAPTORS

TECHNICAL

### RECOMMENDED FOR:

Extra high pressure hydraulic oil lines in applications. Compact dimensions and small bend radius are advantages in installations where space is limited.

### PERFORMANCE:

Exceeds the Performance Requirements of: EN 857 Type 1SC, ISO 11237 Type 1SC.

### CONSTRUCTION:

RYCO Proprietary DK1E design.

### TUBE:

Black, oil resistant synthetic rubber.

### REINFORCEMENT:

One braid of high tensile steel wire.

### COVER:

Black, oil resistant synthetic rubber. No skiving required with T2000 Series Crimp Couplings.

### FEATURES:

The extra high working pressures and excellent impulse life, results in increased service life and minimises equipment downtime.

Compact dimensions and small bend radius are advantages in installations where space is limited.

### TEMPERATURE RANGE:

From -40°C to +100°C (-40°F to +212°F).

### WORKING PRESSURE:

Maximum working pressures are based on 4:1 safety factor (maximum working pressure to minimum burst pressure).

### COUPLINGS:

#### NON-SKIVE ONE-PIECE CRIMP

**T2000 Series** (sizes -04 to -20) pages 187 to 232. Assembly Instructions pages 478.

Not suitable for use with field attachable couplings.

DK1E - ENERGY EXTRA HIGH PRESSURE NON-SKIVE HOSE															
PART NO	HOSE SIZE	NOMINAL HOSE ID	NOMINAL HOSE OD	MAXIMUM WORKING PRESSURE	MINIMUM BURST PRESSURE	MINIMUM BEND RADIUS	AVERAGE WEIGHT	COUPLING SERIES ONE PIECE							
Hose	DN	Dash	mm	inch	mm	inch	bar	psi	bar	psi	mm	inch	kg/m	lb/ft	NON-SKIVE
DK14E	6	-04	6,6	1/4	11,6	0.46	295	4280	1180	17120	40	1.6	0,16	0.11	T2000
DK15E	8	-05	8,5	5/16	13,4	0.53	250	3625	1000	14500	50	2.0	0,20	0.13	T2000
DK16E	10	-06	9,8	3/8	15,0	0.59	230	3340	920	13360	65	2.6	0,24	0.16	T2000
DK18E	12	-08	13,0	1/2	18,3	0.72	200	2900	800	11600	80	3.1	0,31	0.21	T2000
DK110E	16	-10	16,1	5/8	21,5	0.85	150	2175	600	8700	100	3,9	0,38	0.26	T2000
DK112E	19	-12	19,1	3/4	24,7	0.97	125	1815	500	7260	120	4.7	0,44	0.30	T2000
DK116E	25	-16	25,4	1	31,6	1.24	110	1600	440	6400	150	5,9	0,61	0.41	T2000
DK120E	31	-20	31,8	1.1/4	38,4	1.51	100	1450	400	5800	200	7.9	0,79	0.53	T2000

Refer to the latest RYCO Crimp Charts for crimp diameter and mark lengths.

# HOSE

## BRAID

### DK1S

EXTREMELY ABRASION RESISTANT  
EXTRA HIGH PRESSURE  
COMPACT ONE WIRE BRAID HOSE



#### RECOMMENDED FOR:

Extra high pressure hydraulic oil lines in applications where the hose cover is subjected to abrasion. Compact dimensions and small bend radius are advantages in installations where space is limited.

#### PERFORMANCE:

Exceeds the Performance Requirements of:  
EN 857 Type 1SC, ISO 11237 Type 1SC.

#### CONSTRUCTION:

RYCO Proprietary DK1S design.

#### TUBE:

Black, oil resistant synthetic rubber.

#### REINFORCEMENT:

One braid of high tensile steel wire.

#### COVER:

**SLIDER** Black, oil and extremely abrasion resistant synthetic rubber sheathed with a layer of extremely abrasion resistant polyethylene. Flame Resistant, MSHA compliant. Highly visible layline branding for easy and permanent identification. No skiving required with T2000 Series Crimp Couplings.

#### FEATURES:

The extremely abrasion resistant properties of the cover, combined with the extra high working pressures and excellent impulse life, results in increased service life and minimises equipment downtime. Compact dimensions and small bend radius are advantages in installations where space is limited.

#### MSHA - FLAME RESISTANCE:

**SLIDER** meets Flame Resistant Designation "U.S. MSHA" of the US Department of Labor, Mine Safety and Health Administration.

#### TEMPERATURE RANGE:

From -40°C to +100°C (-40°F to +212°F).

#### WORKING PRESSURE:







Maximum working pressures are based on 4:1 safety factor (maximum working pressure to minimum burst pressure).

#### COUPLINGS:

##### NON-SKIVE ONE-PIECE CRIMP

**T2000 Series** (sizes -04 to -20) pages 187 to 232. Assembly Instructions pages 478.

Not suitable for use with field attachable couplings.

DK1S - SLIDER EXTRA HIGH PRESSURE NON-SKIVE HOSE															
PART NO	HOSE SIZE	NOMINAL HOSE ID	NOMINAL HOSE OD	MAXIMUM WORKING PRESSURE	MINIMUM BURST PRESSURE	MINIMUM BEND RADIUS	AVERAGE WEIGHT	COUPLING SERIES ONE PIECE							
Hose	DN	Dash	mm	inch	mm	inch	bar	psi	bar	psi	mm	inch	kg/m	lb/ft	NON-SKIVE
DK14S	6	-04	6,6	1/4	11,6	0.46	295	4280	1180	17120	40	1.6	0,16	0.11	T2000
DK15S	8	-05	8,5	5/16	13,4	0.53	250	3625	1000	14500	50	2.0	0,20	0.13	T2000
DK16S	10	-06	9,8	3/8	15,0	0.59	230	3340	920	13360	65	2.6	0,24	0.16	T2000
DK18S	12	-08	13,0	1/2	18,3	0.72	200	2900	800	11600	80	3.1	0,31	0.21	T2000
DK110S	16	-10	16,1	5/8	21,5	0.85	150	2175	600	8700	100	3,9	0,38	0.26	T2000
DK112S	19	-12	19,1	3/4	24,7	0.97	125	1815	500	7260	120	4.7	0,44	0.30	T2000
DK116S	25	-16	25,4	1	31,6	1.24	110	1600	440	6400	150	5,9	0,61	0.41	T2000
DK120S	31	-20	31,8	1.1/4	38,4	1.51	100	1450	400	5800	200	7.9	0,79	0.53	T2000

Refer to the latest RYCO Crimp Charts for crimp diameter and mark lengths.

# DK2D

EXTRA ABRASION RESISTANT  
EXTRA HIGH PRESSURE  
FRAS  
COMPACT TWO WIRE BRAID HOSE

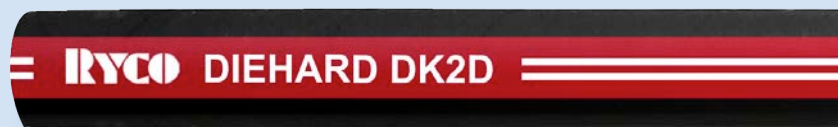

TESTED UP TO 1 MILLION CYCLES

INTRODUCTION

HOSE

COUPLINGS

ADAPTORS

TECHNICAL

### RECOMMENDED FOR:

Extra high pressure hydraulic oil lines in applications where the hose cover is subjected to abrasion. Compact dimensions and small bend radius are advantages in installations where space is limited.

### PERFORMANCE:

Exceeds the Performance Requirements of: EN 857 Type 2SC, ISO 6805 Type 1 & Type 2, ISO 6805 Type 4 (sizes -10 and above), ISO 11237 Type 2SC.

### CONSTRUCTION:

RYCO Proprietary DK2D design.

### TUBE:

Black, oil resistant synthetic rubber.

### REINFORCEMENT:

Two braids of high tensile steel wire.

### COVER:

**DIEHARD™** Black, oil, ozone and extra abrasion resistant synthetic rubber. Flame Resistant, Anti-Static (FRAS) & MSHA compliant. Highly visible layline branding for easy and permanent identification. No skiving required with T2000 Series Crimp Couplings.

### FEATURES:

The very high abrasion resistant properties of the cover, combined with the extra high working pressures and excellent impulse life, results in increased service life and minimises equipment downtime. Compact dimensions and small bend radius are advantages in installations where space is limited.

### FRAS - FLAME RESISTANCE AND ANTI-STATIC:

**DIEHARD™** complies with Flame Resistant and Electrical Resistance (Anti-Static) requirements of Australian Standard AS 2660 and Methods of Test AS 1180.10B and 13A, and requirements of ISO 6805 when tested in accordance with ISO 8030 and ISO 8031.

Meets Flame Resistant Designation "U.S MSHA" of the US Department of Labour, Mine Safety and Health Administration.

### TEMPERATURE RANGE:

From -40°C to +100°C (-40°F to +212°F).

### WORKING PRESSURE:

Maximum working pressures are based on 4:1 safety factor (maximum working pressure to minimum burst pressure).

### COUPLINGS:

#### NON-SKIVE ONE-PIECE CRIMP

**T2000 Series** (sizes -04 to -06) pages 187 to 232. Assembly Instructions pages 478.

Not suitable for use with field attachable couplings.

DK2D - COMPACT EXTRA HIGH PRESSURE NON-SKIVE HOSE															
PART NO	HOSE SIZE	NOMINAL HOSE ID	NOMINAL HOSE OD	MAXIMUM WORKING PRESSURE	MINIMUM BURST PRESSURE	MINIMUM BEND RADIUS	AVERAGE WEIGHT	COUPLING SERIES ONE PIECE							
Hose	DN	Dash	mm	inch	mm	inch	bar	psi	bar	psi	mm	inch	kg/m	lb/ft	NON-SKIVE
DK24D	6	-04	6,7	1/4	13,7	0.54	450	6525	1800	26100	45	1.8	0,30	0.20	T2000
DK25D	8	-05	8,2	5/16	14,8	0.60	420	6100	1680	24400	60	2.4	0,36	0.24	T2000
DK26D	10	-06	9,8	3/8	17,1	0.67	385	5590	1540	22360	70	2.8	0,41	0.27	T2000
DK28D	12	-08	13,0	1/2	20,3	0.80	345	5000	1380	20000	90	3.5	0,55	0.37	T2000
DK210D	16	-10	16,2	5/8	24,1	0.95	290	4210	1160	16840	130	5.1	0,69	0.46	T2000
DK212D	19	-12	19,3	3/4	27,8	1.09	280	4100	1120	16400	160	6.3	0,88	0.59	T2000
DK216D	25	-16	25,8	1	35,6	1.40	200	2900	800	11600	210	8.3	1,31	0.88	T2000
DK220D	31	-20	32,2	1.1/4	43,5	1.71	175	2540	700	10160	280	11.0	1,70	1.14	T2000

Refer to the latest RYCO Crimp Charts for crimp diameter and mark lengths.

# HOSE

## BRAID

### DK2E

EXTRA HIGH PRESSURE  
COMPACT TWO WIRE BRAID HOSE



TESTED UP TO 1 MILLION CYCLES

#### RECOMMENDED FOR:

High pressure hydraulic oil lines. Ideal for high pressure use that requires a compact outside diameter and smaller bend radius than some other two wire braid hoses.

#### PERFORMANCE:

Exceeds the Performance Requirements of: EN 857 Type 2SC, ISO 6805 Type 1 & Type 2, ISO 6805 Type 4 (sizes -10 and above), ISO 11237 Type 2SC.

#### CONSTRUCTION:

RYCO Proprietary DK2E design.

#### TUBE:

Black, oil resistant synthetic rubber.

#### REINFORCEMENT:

Two braids of high tensile steel wire.

#### COVER:

Black, oil resistant synthetic rubber. No skiving required with T2000 Series Crimp Couplings.

#### FEATURES:

The extra high working pressures and excellent impulse life, results in increased service life and minimises equipment downtime.

Compact dimensions and small bend radius are advantages in installations where space is limited.

#### TEMPERATURE RANGE:

From -40°C to +100°C (-40°F to +212°F).

#### WORKING PRESSURE:

Maximum working pressures are based on 4:1 safety factor (maximum working pressure to minimum burst pressure).

#### COUPLINGS:

##### NON-SKIVE ONE-PIECE CRIMP

**T2000 Series** (sizes -04 to -20) pages 187 to 232.

Assembly Instructions pages 478.

Not suitable for use with field attachable couplings.

DK2E - COMPACT EXTRA HIGH PRESSURE NON-SKIVE HOSE															
PART NO	HOSE SIZE	NOMINAL HOSE ID		NOMINAL HOSE OD		MAXIMUM WORKING PRESSURE		MINIMUM BURST PRESSURE		MINIMUM BEND RADIUS		AVERAGE WEIGHT		COUPLING SERIES ONE PIECE	
Hose	DN	Dash	mm	inch	mm	inch	bar	psi	bar	psi	mm	inch	kg/m	lb/ft	NON-SKIVE
DK24E	6	-04	6,7	1/4	13,7	0.54	450	6525	1800	26100	45	1.8	0,30	0.20	T2000
DK25E	8	-05	8,2	5/16	14,8	0.60	420	6100	1680	24400	60	2.4	0,36	0.24	T2000
DK26E	10	-06	9,8	3/8	17,1	0.67	385	5590	1540	22360	70	2.8	0,41	0.27	T2000
DK28E	12	-08	13,0	1/2	20,3	0.80	345	5000	1380	20000	90	3.5	0,55	0.37	T2000
DK210E	16	-10	16,2	5/8	24,1	0.95	290	4210	1160	16840	130	5.1	0,69	0.46	T2000
DK212E	19	-12	19,3	3/4	27,8	1.09	280	4100	1120	16400	160	6.3	0,88	0.59	T2000
DK216E	25	-16	25,8	1	35,6	1.40	200	2900	800	11600	210	8.3	1,31	0.88	T2000
DK220E	31	-20	32,2	1.1/4	43,5	1.71	175	2540	700	10160	280	11.0	1,70	1.14	T2000

Refer to the latest RYCO Crimp Charts for crimp diameter and mark lengths.



# DK2S

EXTREMELY ABRASION RESISTANT  
EXTRA HIGH PRESSURE  
COMPACT TWO WIRE BRAID HOSE



TESTED UP TO 1 MILLION CYCLES

INTRODUCTION

HOSE

COUPLINGS

ADAPTORS

TECHNICAL

### RECOMMENDED FOR:

Extra high pressure hydraulic oil lines in applications where the hose cover is subjected to abrasion. Compact dimensions and small bend radius are advantages in installations where space is limited.

### PERFORMANCE:

Exceeds the Performance Requirements of:  
EN 857 Type 2SC, ISO 6805 Type 1 & Type 2, ISO 6805 Type 4 (sizes -10 and above), ISO 11237 Type 2SC.

### CONSTRUCTION:

RYCO Proprietary DK2S design.

### TUBE:

Black, oil resistant synthetic rubber.

### REINFORCEMENT:

Two braids of high tensile steel wire.

### COVER:

**SLIDER** Black, oil and extremely abrasion resistant synthetic rubber sheathed with a layer of extremely abrasion resistant polyethylene. Flame Resistant, MSHA compliant. Highly visible layline branding for easy and permanent identification. No skiving required with T2000 Series Crimp Couplings.

### FEATURES:

The extremely abrasion resistant properties of the cover, combined with the extra high working pressures and excellent impulse life, results in increased service life and minimises equipment downtime. Compact dimensions and small bend radius are advantages in installations where space is limited.

### MSHA - FLAME RESISTANCE:

**SLIDER** complies with Flame Resistant requirements of Australian Standard AS 2660 and Methods of Test AS 1180.10B. Meets Flame Resistant Designation "U.S. MSHA" of the US Department of Labor, Mine Safety and Health Administration.

### TEMPERATURE RANGE:

From -40°C to +100°C (-40°F to +212°F).

### WORKING PRESSURE:

Maximum working pressures are based on 4:1 safety factor (maximum working pressure to minimum burst pressure).

### COUPLINGS:

#### NON-SKIVE ONE-PIECE CRIMP

**T2000 Series** (sizes -04 to -20) pages 187 to 232. Assembly Instructions pages 478.

Not suitable for use with field attachable couplings.

DK2S - COMPACT EXTRA HIGH PRESSURE NON-SKIVE HOSE															
PART NO	HOSE SIZE	NOMINAL HOSE ID		NOMINAL HOSE OD		MAXIMUM WORKING PRESSURE		MINIMUM BURST PRESSURE		MINIMUM BEND RADIUS		AVERAGE WEIGHT		COUPLING SERIES	
		mm	inch	mm	inch	bar	psi	bar	psi	mm	inch	kg/m	lb/ft	ONE PIECE	
DK24S	6 -04	6,7	1/4	13,7	0.54	450	6525	1800	26100	45	1.8	0,30	0.20	T2000	
DK25S	8 -05	8,2	5/16	14,8	0.60	420	6100	1680	24400	60	2.4	0,36	0.24	T2000	
DK26S	10 -06	9,8	3/8	17,1	0.67	385	5590	1540	22360	70	2.8	0,41	0.27	T2000	
DK28S	12 -08	13,0	1/2	20,3	0.80	345	5000	1380	20000	90	3.5	0,55	0.37	T2000	
DK210S	16 -10	16,2	5/8	24,1	0.95	290	4210	1160	16840	130	5.1	0,69	0.46	T2000	
DK212S	19 -12	19,3	3/4	27,8	1.09	280	4100	1120	16400	160	6.3	0,88	0.59	T2000	
DK216S	25 -16	25,8	1	35,6	1.40	200	2900	800	11600	210	8.3	1,31	0.88	T2000	
DK220S	31 -20	32,2	1.1/4	43,5	1.71	175	2540	700	10160	280	11.0	1,70	1.14	T2000	

Refer to the latest RYCO Crimp Charts for crimp diameter and mark lengths.



# ENERGY EFFICIENT

## ENERGY AND PERFORMANCE

### EC1 & EC2

ENERGY COMPACT HOSE

### E1 & E2

ENERGY HOSE

The agricultural equipment manufacturing and distribution industry has been the cornerstone of RYCO since our humble beginnings. Today, Original Equipment Manufacturer's rely on RYCO to create and supply specialised product that performs above the requirements of our ever increasing, challenging applications.

Agricultural equipment manufacturer's utilise and trust RYCO products in regional and international markets.

The demanding conditions in which these machines operate highlights the proven design features and product durability of RYCO Hydraulic Hose, Adaptors, Bitelok Couplings, and Field Attachable fittings.

You will find RYCO products on cane harvesters, laser levellers, front end loaders and backhoes, timber harvesting equipment, ploughs, bailers, tractors (two through to eight wheel drive) and just about any other implement imaginable. RYCO gives cost effective returns to the farming community and suppliers.

### ENERGY EFFICIENT

RYCO's E1 & E2 & RYCO EC1 & EC2 Hydraulic Hose provides you with superior operator comfort for improved working conditions and precise control for optimum machinery performance. With RYCO on the inside you get the consistent performance needed for maximum yields.

### RYCO PERFORMANCE

RYCO's comprehensive testing and evaluation process guarantees you the performance and quality required to meet the demands of today's applications, by safely conveying fluids at high pressure.

RYCO ENERGY hose has performance of:

#### RYCO EC1

EN 857 Type 1SC & ISO 11237 Type 1SC .

#### RYCO EC2

EN 857 Type 2SC, ISO 11237 Type 2SC & SAE 100R16

#### RYCO E1

AS3791 100R1AT, DIN 20022-1SN, EN 853 Type 1SN, ISO 1436 Types R1AT & 1SN, SAE 100R1AT.

#### RYCO E2

AS3791 100R2AT, DIN 20022-2SN, EN 853 Type 2SN, ISO 1436 Types R2AT & 2SN, SAE 100R2AT.

### WE HAVE YOU COVERED

RYCO ENERGY contains two braids of high tensile steel wire. The E2 & EC range of hoses is 1/4" to 1".

RYCO ENERGY hose cover is black, oil resistant synthetic rubber.

#### RYCO EC

BITELOK Non-Skive One piece Couplings T2000.

#### RYCO E2

BITELOK Non-Skive One piece Couplings T2000 & T7000.

Field Attachable Non-Skive 6000 insert (L000 ferrule).



# EC1

## ENERGY COMPACT ONE WIRE BRAID HOSE



INTRODUCTION

HOSE

COUPLINGS

ADAPTORS

TECHNICAL

### RECOMMENDED FOR:

High pressure hydraulic oil lines. Ideal for high pressure use that requires a more compact outside diameter than some other one wire braid hoses.

### PERFORMANCE:

Meets or Exceeds the Performance Requirements of: EN 857 Type 1SC, ISO 11237 Type 1SC.

### TUBE:

Black, oil resistant synthetic rubber.

### REINFORCEMENT:

One braid of high tensile steel wire.

### COVER:

Black, oil resistant synthetic rubber. No skiving required with T2000 Series Crimp Couplings.

### TEMPERATURE RANGE:

From -40°C to +100°C (-40°F to +212°F).

### WORKING PRESSURE:

Maximum working pressures are based on 4:1 safety factor (maximum working pressure to minimum burst pressure).

### COUPLINGS:

#### NON-SKIVE ONE-PIECE CRIMP

**T2000 Series** (sizes -04 to -16) pages 187 to 232. Assembly Instructions pages 478.

EC1 - ENERGY COMPACT HOSE															
PART NO	HOSE SIZE	NOMINAL HOSE ID		NOMINAL HOSE OD		MAXIMUM WORKING PRESSURE		MINIMUM BURST PRESSURE		MINIMUM BEND RADIUS		AVERAGE WEIGHT		COUPLING SERIES ONE PIECE	
Hose	DN	Dash	mm	inch	mm	inch	bar	psi	bar	psi	mm	inch	kg/m	lb/ft	NON-SKIVE
EC14	6	-04	6,6	1/4	12,2	0.48	225	3250	900	13000	50	2.0	0,20	0.13	T2000
EC15	8	-05	8,2	5/16	13,9	0.55	215	3100	860	12400	55	2.2	0,22	0.15	T2000
EC16	10	-06	9,8	3/8	15,6	0.61	180	2600	720	10400	65	2.6	0,26	0.17	T2000
EC18	12	-08	13,0	1/2	19,0	0.75	160	2300	640	9200	85	3.3	0,33	0.22	T2000
EC110	16	-10	16,2	5/8	22,2	0.80	130	1900	520	7600	100	3.9	0,44	0.30	T2000
EC112	19	-12	19,1	3/4	25,6	1.01	105	1500	420	6000	115	4.5	0,50	0.34	T2000
EC116	25	-16	25,4	1	33,6	1.32	90	1280	360	5120	150	5.9	0,75	0.50	T2000

Refer to the latest RYCO Crimp Charts for crimp diameter and mark lengths.

# HOSE

## BRAID

### EC2

#### ENERGY COMPACT TWO WIRE BRAID HOSE



#### RECOMMENDED FOR:

High pressure hydraulic oil lines. Ideal for high pressure use that requires a compact outside diameter and smaller bend radius than some other two wire braid hoses.

#### PERFORMANCE:

Meets or Exceeds the Performance Requirements of: EN 857 Type 2SC, ISO 11237 Type 2SC, SAE 100R16.

#### TUBE:

Black, oil resistant synthetic rubber.

#### REINFORCEMENT:

Two braids of high tensile steel wire.

#### COVER:

Black, oil resistant synthetic rubber. No skiving required with T2000 Series Crimp Couplings.

#### TEMPERATURE RANGE:

From -40°C to +100°C (-40°F to +212°F).

#### WORKING PRESSURE:

Maximum working pressures are based on 4:1 safety factor (maximum working pressure to minimum burst pressure).

#### COUPLINGS:

##### NON-SKIVE ONE-PIECE CRIMP

**T2000 Series** (sizes -04 to -16) pages 187 to 232. Assembly Instructions pages 478.

EC2 - ENERGY COMPACT HOSE															
PART NO	HOSE SIZE	NOMINAL HOSE ID	NOMINAL HOSE OD	MAXIMUM WORKING PRESSURE	MINIMUM BURST PRESSURE	MINIMUM BEND RADIUS	AVERAGE WEIGHT	COUPLING SERIES ONE PIECE							
Hose	DN	Dash	mm	inch	mm	inch	bar	psi	bar	psi	mm	inch	kg/m	lb/ft	NON-SKIVE
EC24	6	-04	6,6	1/4	13,4	0.53	400	5800	1600	23200	50	2.0	0,28	0.19	T2000
EC25	8	-05	8,2	5/16	14,9	0.59	350	5100	1400	20400	55	2.2	0,41	0.27	T2000
EC26	10	-06	9,8	3/8	17,3	0.68	330	4800	1320	19200	65	2.5	0,43	0.29	T2000
EC28	12	-08	13,0	1/2	20,3	0.80	275	4000	1100	16000	90	3.5	0,51	0.34	T2000
EC210	16	-10	16,2	5/8	23,6	0.93	250	3625	1000	14500	100	4.0	0,63	0.42	T2000
EC212	19	-12	19,1	3/4	27,6	1.09	215	3100	860	12400	120	4.7	0,81	0.55	T2000
EC216	25	-16	25,4	1	35,8	1.40	165	2400	660	9700	150	5.9	1,10	0.74	T2000

Refer to the latest RYCO Crimp Charts for crimp diameter and mark lengths.



# ECP1 PILOT

PILOT  
COMPACT ONE WIRE BRAID HOSE



## RECOMMENDED FOR:

High pressure hydraulic oil pilot lines. Compact dimensions and very small bend radius are advantages in installations where space is limited.

## PERFORMANCE:

RYCO Proprietary ECP1 Design.

## CONSTRUCTION:

RYCO Proprietary ECP1 Design.

## TUBE:

Black, oil resistant synthetic rubber.

## REINFORCEMENT:

One braid of high tensile steel wire.

## COVER:

Black, oil resistant synthetic rubber. No skiving required with T2000 Series Crimp Couplings.

## FEATURES:

Light and extremely flexible, with compact dimensions and a very small bend radius that are advantages in installations where space is limited. Low volumetric expansion ensures maximum responsiveness of hydraulic controls.

## TEMPERATURE RANGE:

From -40°C to +100°C (-40°F to +212°F), with intermittent operation up to +121°C (+250°F).

## WORKING PRESSURE:

Maximum working pressures are based on 4:1 safety factor (maximum working pressure to minimum burst pressure).

## COUPLINGS:

### NON-SKIVE ONE-PIECE CRIMP

**T2000 Series** (sizes -03 to -08) pages 187 to 232. Assembly Instructions pages 478.

ECP1 - PILOT COMPACT HOSE												COUPLING SERIES			
PART NO	HOSE SIZE	NOMINAL HOSE ID		NOMINAL HOSE OD		MAXIMUM WORKING PRESSURE		MINIMUM BURST PRESSURE		MINIMUM BEND RADIUS		AVERAGE WEIGHT		ONE PIECE	
Hose	DN	Dash	mm	inch	mm	inch	bar	psi	bar	psi	mm	inch	kg/m	lb/ft	NON-SKIVE
ECP13	5	-03	5,0	3/16	10,3	0.41	125	1800	500	7200	25	1.0	0.11	0.05	T2000
ECP14	6	-04	6,7	1/4	11,8	0.46	125	1800	500	7200	30	1.2	0.14	0.06	T2000
ECP15	8	-05	8,3	5/16	13,3	0.52	125	1800	500	7200	40	1.6	0.16	0.07	T2000
ECP16	10	-06	9,9	3/8	14,9	0.59	125	1800	500	7200	50	2.0	0.19	0.09	T2000
ECP18	12	-08	13,0	1/2	18,3	0.72	125	1800	500	7200	60	2.4	0.28	0.13	T2000

Refer to the latest RYCO Crimp Charts for crimp diameter and mark lengths.

### E1

#### ENERGY ONE WIRE BRAID HOSE



#### RECOMMENDED FOR:

High pressure hydraulic oil lines.

#### PERFORMANCE:

Meets or Exceeds the Performance Requirements of: AS 3791 100R1AT, DIN 20022-1SN, EN 853 Type 1SN, ISO 1436 Types R1AT & 1SN, SAE 100R1AT.

#### TUBE:

Black, oil resistant synthetic rubber.

#### REINFORCEMENT:

One braid of high tensile steel wire.

#### COVER:

Black, oil resistant synthetic rubber. No skiving required with T2000 Series Crimp Couplings and K000 Series Field Attachable Couplings.

#### TEMPERATURE RANGE:

From -40°C to +100°C (-40°F to +212°F).

#### WORKING PRESSURE:

Maximum working pressures are based on 4:1 safety factor (maximum working pressure to minimum burst pressure).

#### COUPLINGS:

##### NON-SKIVE ONE-PIECE CRIMP

**T2000 Series** (sizes -04 to -16) pages 187 to 232.  
Assembly Instructions pages 478.

##### FIELD ATTACHABLE NON-SKIVE

**6000 SERIES** insert (sizes -04 to -16) pages 250 to 271.

**K000 Series** ferrule (sizes -04 to -16) page 353.  
Assembly Instructions page 476.

E1 - ENERGY HOSE																
PART NO	HOSE SIZE	NOMINAL HOSE ID		NOMINAL HOSE OD		MAXIMUM WORKING PRESSURE		MINIMUM BURST PRESSURE		MINIMUM BEND RADIUS		AVERAGE WEIGHT		ONE PIECE	FIELD ATT	
Hose	DN	Dash	mm	inch	mm	inch	bar	psi	bar	psi	mm	inch	kg/m	lb/ft	NON-SKIVE	
E13	5	03	5,0	3/16	11,4	0.45	250	3,625	1000	14500	90	3.5	0,18	0.12	T2000	6000 (K000)
E14	6	-04	6,6	1/4	13,0	0.52	225	3250	900	13000	100	4.0	0,22	0.15	T2000	6000 (K000)
E15	8	-05	8,2	5/16	14,6	0.59	215	3100	860	12400	115	4.5	0,25	0.17	T2000	
E16	10	-06	9,8	3/8	16,7	0.68	180	2600	720	10400	125	5.0	0,31	0.21	T2000	6000 (K000)
E18	12	-08	13,0	1/2	20,0	0.80	160	2300	640	9200	180	7.0	0,39	0.26	T2000	6000 (K000)
E110	16	-10	16,2	5/8	23,4	0.93	130	1900	520	7600	200	7.9	0,49	0.33	T2000	6000 (K000)
E112	19	-12	19,1	3/4	27,4	1.09	105	1500	420	6000	240	9.5	0,62	0.42	T2000	6000 (K000)
E116	25	-16	25,4	1	35,8	1.40	90	1280	360	5120	300	11.8	0,90	0.60	T2000	6000 (K000)

Refer to the latest RYCO Crimp Charts for crimp diameter and mark lengths.

# E2

## ENERGY TWO WIRE BRAID HOSE

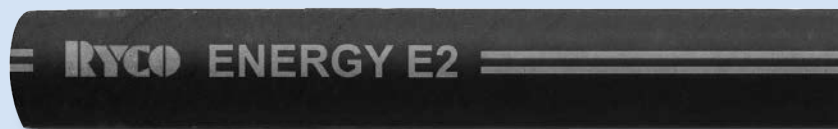

INTRODUCTION

HOSE

COUPLINGS

ADAPTORS

TECHNICAL

### RECOMMENDED FOR:

High pressure hydraulic oil lines.

### PERFORMANCE:

Meets or Exceeds the Performance Requirements of:  
AS 3791 100R2AT, DIN 20022 - 2SN, EN 853 Type 2SN,  
ISO 1436 Types R2AT & 2SN, SAE 100R2AT.

### TUBE:

Black, oil resistant synthetic rubber.

### REINFORCEMENT:

Two braids of high tensile steel wire.

### COVER:

Black, oil resistant synthetic rubber. No skiving required with  
T2000 and T7000 Series Crimp Couplings and L000 Series  
Field Attachable Couplings.

### TEMPERATURE RANGE:

From -40°C to +100°C (-40°F to +212°F).

### WORKING PRESSURE:

Maximum working pressures are based on 4:1 safety factor  
(maximum working pressure to minimum burst pressure).

### COUPLINGS:

#### NON-SKIVE ONE-PIECE CRIMP

**T2000 Series** (sizes -04 to -16) pages 187 to 232.

**T7000 Series** (sizes -06 to -16) pages 272 to 302.

Assembly Instructions pages 478.

#### FIELD ATTACHABLE NON-SKIVE

**6000 SERIES** insert (sizes -04 to -16) pages 250 to 271.

**L000 Series** ferrule (sizes -04 to -16) page 353.

Assembly Instructions page 476.

E2 - ENERGY HOSE																	
PART NO	HOSE SIZE	NOMINAL HOSE ID		NOMINAL HOSE OD		MAXIMUM WORKING PRESSURE		MINIMUM BURST PRESSURE		MINIMUM BEND RADIUS		AVERAGE WEIGHT		ONE PIECE	FIELD ATT		
Hose	DN	Dash	mm	inch	mm	inch	bar	psi	bar	psi	mm	inch	kg/m	lb/ft	NON-SKIVE		
E24	6	-04	6,6	1/4	14,6	0.59	400	5800	1600	23200	100	3.9	0,35	0.24	T2000		6000 (L000)
E25	8	-05	8,2	5/16	16,4	0.65	350	5100	1400	20400	115	4.5	0,42	0.28	T2000		
E26	10	-06	9,8	3/8	18,5	0.74	330	4800	1320	19200	125	5.0	0,51	0.34	T2000	T7000	6000 (L000)
E28	12	-08	13,0	1/2	21,7	0.86	275	4000	1100	16000	180	7.0	0,65	0.44	T2000	T7000	6000 (L000)
E210	16	-10	16,2	5/8	24,9	0.99	250	3625	1000	14500	200	7.9	0,75	0.50	T2000	T7000	6000 (L000)
E212	19	-12	19,1	3/4	28,9	1.15	215	3100	860	12400	240	9.5	0,93	0.62	T2000	T7000	6000 (L000)
E216	25	-16	25,4	1	37,3	1.48	165	2400	660	9600	300	11.8	1,30	0.87	T2000	T7000	6000 (L000)

Refer to the latest RYCO Crimp Charts for crimp diameter and mark lengths.

# HOSE

## BRAID

### T1D

EXTRA ABRASION RESISTANT  
FRAS  
ONE WIRE BRAID HOSE



#### RECOMMENDED FOR:

High pressure hydraulic oil lines in applications where the outside cover of the hose is subjected to abrasion that may cause premature failure of standard hoses.

#### PERFORMANCE:

Meets or Exceeds the Performance Requirements of:  
AS 3791 100R1AT, DIN 20022-1SN, EN 853 Type 1SN,  
ISO 1436 Types R1AT & 1SN, SAE 100R1AT.

#### TUBE:

Black, oil resistant synthetic rubber.

#### REINFORCEMENT:

One braid of high tensile steel wire.

#### COVER:

**DIEHARD™** Black, oil and extra abrasion resistant synthetic rubber. Flame Resistant, Anti-Static (FRAS) & MSHA compliant. Highly visible layline branding for easy and permanent identification. No skiving required with T2000 Series Crimp Couplings and K000 Series Field Attachable Couplings.

#### FEATURES:

The very high abrasion resistant properties of the cover, combined with the high working pressures and excellent impulse life, when tested to EN 853 Type 1SN/SAE 100R1AT test conditions, result in increased service life and minimise equipment downtime.

#### FRAS - FLAME RESISTANCE AND ANTI-STATIC:

**DIEHARD™** complies with Flame Resistant and Electrical Resistance (Anti-Static) requirements of Australian Standard AS 2660 and Methods of Test AS 1180.10B and 13A. Meets Flame Resistant Designation "U.S. MSHA" of the US Department of Labor, Mine Safety and Health Administration.

#### TEMPERATURE RANGE:

From -40°C to +100°C (-40°F to +212°F).  
For water, emulsions etc. see page 58.

#### WORKING PRESSURE:

Maximum working pressures are based on 4:1 safety factor (maximum working pressure to minimum burst pressure).

#### THIRD PARTY APPROVALS:

ABS, DNV-GL, LR, MED, USCG, GOST-R, BV, RINA, KR & MA-KA.

#### COUPLINGS:

##### NON-SKIVE ONE-PIECE CRIMP

**T2000 Series** (sizes -03 to -32) pages 187 to 232.  
Assembly Instructions pages 478.

##### FIELD ATTACHABLE NON-SKIVE

**6000 SERIES** insert (sizes -03 to -16) pages 250 to 271.  
**K000 Series** ferrule (sizes -03 to -16) page 353.  
Assembly Instructions page 476.

T1D - DIEHARD NON-SKIVE HOSE																
PART NO	HOSE SIZE	NOMINAL HOSE ID		NOMINAL HOSE OD		MAXIMUM WORKING PRESSURE		MINIMUM BURST PRESSURE		MINIMUM BEND RADIUS		AVERAGE WEIGHT		ONE PIECE	FIELD ATT	
Hose	DN	Dash	mm	inch	mm	inch	bar	psi	bar	psi	mm	inch	kg/m	lb/ft	NON-SKIVE	
T13D	5	-03	4,8	3/16	11,7	0.46	250	3600	1000	14500	35	1.4	0,19	0.13	T2000	6000 (K000)
T14D	6	-04	6,6	1/4	13,3	0.52	225	3250	900	13000	40	1.5	0,22	0.15	T2000	6000 (K000)
T15D	8	-05	8,2	5/16	14,9	0.59	215	3100	860	12400	50	2.0	0,25	0.17	T2000	
T16D	10	-06	9,8	3/8	17,3	0.68	180	2600	720	10400	50	2.0	0,31	0.21	T2000	6000 (K000)
T18D	12	-08	13,0	1/2	20,3	0.80	160	2300	640	9200	75	3.0	0,39	0.26	T2000	6000 (K000)
T110D	16	-10	16,2	5/8	23,6	0.93	130	1900	520	7600	90	3.5	0,49	0.33	T2000	6000 (K000)
T112D	19	-12	19,1	3/4	27,6	1.09	105	1500	420	6000	110	4.3	0,62	0.42	T2000	6000 (K000)
T116D	25	-16	25,4	1	35,5	1.40	90	1300	360	5200	140	5.5	0,90	0.60	T2000	6000 (K000)
T120D	31	-20	31,8	1.1/4	43,2	1.70	65	945	260	3780	210	8.3	1,21	0.81	T2000	
T124D	38	-24	38,1	1.1/2	50,2	1.98	50	725	200	2900	250	9.8	1,45	0.97	T2000	
T132D	51	-32	50,8	2	63,6	2.50	40	580	160	2320	315	12.4	2,09	1.40	T2000	

\* When using A000 Series Field Attachable Couplings on T1D Series Hose, cover of hose must be skived at ends.  
Refer to the latest RYCO Crimp Charts for crimp diameter and mark lengths.





# T1S

EXTREMELY ABRASION RESISTANT  
ONE WIRE BRAID HOSE

**RECOMMENDED FOR:**

High pressure hydraulic oil lines.

**PERFORMANCE:**

Meets or Exceeds the Performance Requirements of:  
AS 3791 100R1AT, DIN 20022-1SN, EN 853 Type 1SN,  
ISO 1436 Types R1AT & 1SN, SAE 100R1AT.

**TUBE:**

Black, oil resistant synthetic rubber.

**REINFORCEMENT:**

One braid of high tensile steel wire.

**COVER:**

**SLIDER** Black, oil and extremely abrasion resistant synthetic rubber sheathed with a layer of extremely abrasion resistant polyethylene. Flame Resistant, MSHA compliant. Highly visible layline branding for easy and permanent identification. No skiving required with T2000 Series Crimp Couplings.

**MSHA - FLAME RESISTANCE:**

**SLIDER** complies with Flame Resistant requirements of Australian Standard AS 2660 and Methods of Test AS 1180.10B. Meets Flame Resistant Designation "U.S. MSHA" of the US Department of Labor, Mine Safety and Health Administration.

**TEMPERATURE RANGE:**

From -40°C to +100°C (-40°F to +212°F).  
For water, emulsions etc. see page 58..

**WORKING PRESSURE:**

Maximum working pressures are based on 4:1 safety factor (maximum working pressure to minimum burst pressure).

**THIRD PARTY APPROVALS:**

ABS, DNV-GL, LR, MED, USCG, GOST-R, BV, RINA, KR & MA-KA.

**COUPLINGS:**

**NON-SKIVE ONE-PIECE CRIMP**

**T2000 Series** (sizes -03 to -32) pages 187 to 232.  
Assembly Instructions pages 478.

T1S - SLIDER NON-SKIVE HOSE															
PART NO	HOSE SIZE	NOMINAL HOSE ID		NOMINAL HOSE OD		MAXIMUM WORKING PRESSURE		MINIMUM BURST PRESSURE		MINIMUM BEND RADIUS		AVERAGE WEIGHT		COUPLING SERIES ONE PIECE	
Hose	DN	Dash	mm	inch	mm	inch	bar	psi	bar	psi	mm	inch	kg/m	lb/ft	NON-SKIVE
T13S	5	-03	4,8	3/16	11,7	0.46	250	3600	1000	14500	35	1.4	0,19	0.13	T2000
T14S	6	-04	6,6	1/4	13,3	0.52	225	3250	900	13000	40	1.5	0,22	0.15	T2000
T15S	8	-05	8,2	5/16	14,9	0.59	215	3100	860	12400	50	2.0	0,25	0.17	T2000
T16S	10	-06	9,8	3/8	17,3	0.68	180	2600	720	10400	50	2.0	0,31	0.21	T2000
T18S	12	-08	13,0	1/2	20,3	0.80	160	2300	640	9200	75	3.0	0,39	0.26	T2000
T110S	16	-10	16,2	5/8	23,6	0.93	130	1900	520	7600	90	3.5	0,49	0.33	T2000
T112S	19	-12	19,1	3/4	27,6	1.09	105	1500	420	6000	110	4.3	0,62	0.42	T2000
T116S	25	-16	25,4	1	35,5	1.40	90	1300	360	5200	140	5.5	0,90	0.60	T2000
T120S	31	-20	31,8	1.1/4	43,2	1.70	65	945	260	3780	210	8.3	1,21	0.81	T2000
T124S	38	-24	38,1	1.1/2	50,2	1.98	50	725	200	2900	250	9.8	1,45	0.97	T2000
T132S	51	-32	50,8	2	63,6	2.50	40	580	160	2320	315	12.4	2,09	1.40	T2000

Refer to the latest RYCO Crimp Charts for crimp diameter and mark lengths.

# HOSE

## BRAID

### T1F

FIRE SUPPRESSION  
ONE WIRE BRAID HOSE

**RYCO T1F FIRE SUPPRESSION**



#### RECOMMENDED FOR

Use in Fire Suppression Systems of off-road vehicles, mining equipment, stationary engines, etc. The hose is coloured red, for easy identification as part of the Fire Suppression System.

#### PERFORMANCE:

Meets or Exceeds the Performance Requirements of: AS 3791 100R1AT, DIN 20022-1SN, EN 853 Type 1SN, ISO 1436 Types R1AT & 1SN, SAE 100R1AT.

#### TUBE:

Black, oil resistant synthetic rubber. Resistant to aqueous film forming foam, dry chemical powder, carbon dioxide, and water based fire extinguishing agents.

#### REINFORCEMENT:

One braid of high tensile steel wire.

#### COVER:

Red, heat resistant, abrasion resistant and oil resistant rubber. Flame Resistant to Australian Standard AS 2660 and U.S. MSHA requirements. Highly visible layline branding for easy and permanent identification. No skiving required with T2000 Series Crimp Couplings and K000 Series Field Attachable Couplings.

#### FRAS - FLAME RESISTANCE AND ANTI-STATIC:

Complies with Flame Resistant requirements of Australian Standard AS 2660 and Method of Test AS 1180.10B Meets Flame Resistant Designation "U.S. MSHA" of the US Department of Labor, Mine Safety and Health Administration.

#### TEMPERATURE RANGE:

From -40°C to +100°C (-40°F to +212°F).  
For water, emulsions etc. see page 58..

#### WORKING PRESSURE:

Maximum working pressures are based on 4:1 safety factor (maximum working pressure to minimum burst pressure).

#### THIRD PARTY APPROVALS:

ABS, DNV-GL, LR, MED, USCG, GOST-R, BV, RINA and KR.

#### COUPLINGS:

##### NON-SKIVE ONE-PIECE CRIMP

**T2000 Series** (sizes -03 to -16) pages 187 to 232.  
Assembly Instructions pages 478.

##### FIELD ATTACHABLE NON-SKIVE

**6000 SERIES** insert (sizes -03 to -16) pages 250 to 271.  
**K000 Series** ferrule (sizes -03 to -16) page 353.  
Assembly Instructions page 476.

T1F - FIRE SUPPRESSION NON-SKIVE HOSE																
PART NO	HOSE SIZE	NOMINAL HOSE ID		NOMINAL HOSE OD		MAXIMUM WORKING PRESSURE		MINIMUM BURST PRESSURE		MINIMUM BEND RADIUS		AVERAGE WEIGHT		ONE PIECE	FIELD ATT	
Hose	DN	Dash	mm	inch	mm	inch	bar	psi	bar	psi	mm	inch	kg/m	lb/ft	NON-SKIVE	
T13F	5	-03	4,8	3/16	11,7	0.46	250	3600	1000	14500	90	3.5	0,19	0.13	T2000	6000 (K000)
T14F	6	-04	6,6	1/4	13,3	0.52	225	3250	900	13000	100	3.9	0,22	0.15	T2000	6000 (K000)
T15F	8	-05	8,2	5/16	14,9	0.59	215	3100	860	12400	115	4.5	0,25	0.17	T2000	
T16F	10	-06	9,8	3/8	17,3	0.68	180	2600	720	10400	125	5.0	0,31	0.21	T2000	6000 (K000)
T18F	12	-08	13,0	1/2	20,3	0.80	160	2300	640	9200	180	7.0	0,39	0.26	T2000	6000 (K000)
T110F	16	-10	16,2	5/8	23,6	0.93	130	1900	520	7600	200	7.9	0,49	0.33	T2000	6000 (K000)
T112F	19	-12	19,1	3/4	27,6	1.09	105	1500	420	6000	240	9.5	0,62	0.41	T2000	6000 (K000)
T116F	25	-16	25,4	1	35,5	1.40	90	1300	360	5200	300	11.8	0,90	0.60	T2000	6000 (K000)

Refer to the latest RYCO Crimp Charts for crimp diameter and mark lengths.

# T2D

EXTRA ABRASION RESISTANT  
FRAS  
TWO WIRE BRAID HOSE

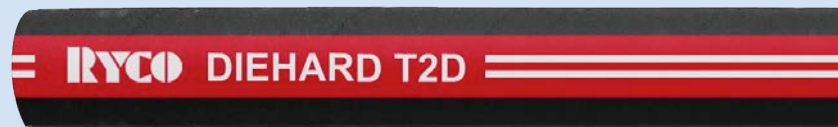

INTRODUCTION

HOSE

COUPLINGS

ADAPTORS

TECHNICAL

### RECOMMENDED FOR:

High pressure hydraulic oil lines in applications where the outside cover of the hose is subjected to abrasion that may cause premature failure of standard hoses.

### PERFORMANCE:

Meets or Exceeds the Performance Requirements of:  
AS 3791 100R2AT, DIN 20022 - 2SN, EN 853 Type 2SN,  
ISO 1436 Types R2AT & 2SN, SAE 100R2AT.

### TUBE:

Black, oil resistant synthetic rubber.

### REINFORCEMENT:

Two braids of high tensile steel wire.

### COVER:

**DIEHARD™** Black, oil and extra abrasion resistant synthetic rubber. Flame Resistant, Anti-Static (FRAS) & MSHA compliant. Highly visible layline branding for easy and permanent identification. No skiving required with T2000 and T7000 Series Crimp Couplings and L000 Series Field Attachable Couplings.

### FEATURES:

The very high abrasion resistant properties of the cover, combined with the high working pressures and excellent impulse life when tested to EN 853 Type 2SN/SAE 100R2AT test conditions result in, increased service life and minimise equipment downtime.

### FRAS - FLAME RESISTANCE AND ANTI-STATIC:

**DIEHARD™** complies with Flame Resistant and Electrical Resistance (Anti-Static) requirements of Australian Standard AS 2660 and Methods of Test AS 1180.10B and 13A. Meets Flame Resistant Designation "U.S. MSHA" of the US Department of Labor, Mine Safety and Health Administration.

### TEMPERATURE RANGE:

From -40°C to +100°C (-40°F to +212°F).  
For water, emulsions etc. see page 58..

### WORKING PRESSURE:

Maximum working pressures are based on 4:1 safety factor (maximum working pressure to minimum burst pressure).

### THIRD PARTY APPROVALS:

ABS, DNV-GL, LR, MED, USCG, GOST-R, BV, RINA, KR & MA-KA.

### COUPLINGS:

#### NON-SKIVE ONE-PIECE CRIMP

**T2000 Series** (sizes -04 to -48) pages 187 to 232.

**T7000 Series** (sizes -06 to -32) pages 272 to 302.  
Assembly Instructions pages 478.

#### FIELD ATTACHABLE NON-SKIVE

**6000 SERIES** insert (sizes -04 to -20) pages 250 to 271.

**L000 Series** ferrule (sizes -04 to -20) page 353.  
Assembly Instructions page 476.

T2D - DIEHARD NON-SKIVE HOSE																
PART NO	HOSE SIZE	NOMINAL HOSE ID		NOMINAL HOSE OD		MAXIMUM WORKING PRESSURE		MINIMUM BURST PRESSURE		MINIMUM BEND RADIUS		AVERAGE WEIGHT		ONE PIECE	FIELD ATT	
Hose	DN	Dash	mm	inch	mm	inch	bar	psi	bar	psi	mm	inch	kg/m	lb/ft	NON-SKIVE	
T24D	6	-04	6,6	1/4	14,6	0.59	420	6100	1680	24400	100	3.9	0,35	0.24	T2000	6000 (L000)
T25D	8	-05	8,2	5/16	16,4	0.65	350	5100	1400	20400	114	4.5	0,42	0.28	T2000	
*T26D	10	-06	9,8	3/8	18,5	0.74	350	5100	1400	20400	125	5.0	0,51	0.34	T2000	T7000 6000 (L000)
T28D	12	-08	13,0	1/2	21,7	0.86	350	5100	1400	20400	178	7.0	0,65	0.44	T2000	T7000 6000 (L000)
*T210D	16	-10	16,2	5/8	24,9	0.99	250	3600	1000	14400	200	7.9	0,75	0.50	T2000	T7000 6000 (L000)
T212D	19	-12	19,1	3/4	28,9	1.15	215	3100	860	12400	240	9.5	0,93	0.62	T2000	T7000 6000 (L000)
T216D	25	-16	25,4	1	37,3	1.48	175	2500	700	10000	300	11.8	1,30	0.87	T2000	T7000 6000 (L000)
*T220D	31	-20	31,8	1.1/4	47,2	1.87	140	2000	560	8000	420	16.5	1,97	1.33	T2000	T7000 6000 (L000)
T224D	38	-24	38,1	1.1/2	54,2	2.13	100	1450	400	5800	500	19.7	2,48	1.67	T2000	T7000
T232D	51	-32	50,8	2	66,8	2.63	90	1300	360	5200	600	23.6	3,02	2.03	T2000	T7000
T240D	63	-40	63,5	2.1/2	80,1	3.15	70	1000	280	4000	760	29.9	3,70	2.49	T2000	
T248D	76	-48	76,2	3	91,3	3.59	70	1000	280	4000	900	35.4	3,99	2.68	T2000	

\* Hoses must only be used at current MBR (not half the SAE MBR) when used with T7000 couplings.

- When using B000 Series Field Attachable Couplings on T2D Series Hose, cover of hose must be skived at ends. Refer to the latest RYCO Crimp Charts for crimp diameter and mark lengths.

# HOSE

## BRAID

### T2S

EXTREMELY ABRASION RESISTANT  
TWO WIRE BRAID HOSE

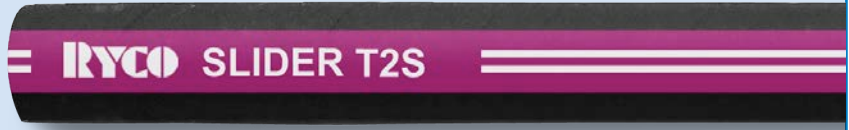

#### RECOMMENDED FOR:

High pressure hydraulic oil lines in applications where the outside cover of the hose is subjected to sliding abrasion that may cause premature failure of standard hoses.

#### PERFORMANCE:

Meets or Exceeds the Performance Requirements of: AS 3791 100R2AT, DIN 20022-2SN, EN 853 Type 2SN, ISO 1436 Type 2AT, SAE 100R2AT.

#### TUBE:

Black, oil resistant synthetic rubber.

#### REINFORCEMENT:

Two braids of high tensile steel wire.

#### COVER:

**SLIDER** Black, oil and extremely abrasion resistant synthetic rubber sheathed with a layer of extremely abrasion resistant polyethylene. Flame Resistant, MSHA compliant. Highly visible layline branding for easy and permanent identification. No skiving required with T2000 & T7000 Series Crimp Couplings.

#### MSHA - FLAME RESISTANCE:

**SLIDER** complies with Flame Resistant requirements of Australian Standard AS 2660 and Methods of Test AS 1180.10B. Meets Flame Resistant Designation "U.S. MSHA" of the US Department of Labor, Mine Safety and Health Administration.

#### TEMPERATURE RANGE:

From -40°C to +100°C (-40°F to +212°F).  
For water, emulsions etc. see page 58.

#### WORKING PRESSURE:

Maximum working pressures are based on 4:1 safety factor (maximum working pressure to minimum burst pressure).

#### THIRD PARTY APPROVALS:

ABS, DNV-GL, LR, MED, USCG, GOST-R, BV, RINA, KR & MA-KA.

#### COUPLINGS:

##### NON-SKIVE ONE-PIECE CRIMP

**T2000 Series** (sizes -04 to -32) pages 187 to 232.

**T7000 Series** (sizes -05 to -32) pages 272 to 302.

Assembly Instructions pages 478.

T2S - SLIDER NON-SKIVE HOSE												COUPLING SERIES				
PART NO	HOSE SIZE	NOMINAL HOSE ID	NOMINAL HOSE OD	MAXIMUM WORKING PRESSURE	MINIMUM BURST PRESSURE	MINIMUM BEND RADIUS	AVERAGE WEIGHT			ONE PIECE						
Hose	DN	Dash	mm	inch	mm	inch	bar	psi	bar	psi	mm	inch	kg/m	lb/ft	NON-SKIVE	
T24S	6	-04	6,6	1/4	14,9	0.59	420	6100	1680	24400	100	3.9	0,35	0.24	T2000	
T25S	8	-05	8,2	5/16	16,5	0.65	350	5100	1400	20400	114	4.5	0,42	0.28	T2000	
T26S	10	-06	9,8	3/8	18,9	0.74	350	5100	1400	20400	125	5.0	0,51	0.34	T2000	T7000
T28S	12	-08	13,0	1/2	21,9	0.86	350	5100	1400	20400	178	7.0	0,65	0.44	T2000	T7000
T210S	16	-10	16,2	5/8	25,1	0.99	250	3600	1000	14400	200	7.9	0,75	0.50	T2000	T7000
T212S	19	-12	19,1	3/4	29,1	1.15	215	3100	860	12400	240	9.5	0,93	0.62	T2000	T7000
T216S	25	-16	25,4	1	37,5	1.48	175	2500	700	10000	300	11.8	1,30	0.87	T2000	T7000
T220S	31	-20	31,8	1.1/4	47,6	1.87	140	2000	560	8000	420	16.5	1,97	1.33	T2000	T7000
T224S	38	-24	38,1	1.1/2	54,1	2.13	100	1450	400	5800	500	19.7	2,48	1.67	T2000	T7000
T232S	51	-32	50,8	2	66,8	2.63	90	1300	360	5200	600	23.6	3,02	2.03	T2000	T7000

Refer to the latest RYCO Crimp Charts for crimp diameter and mark lengths.



# T2C

## LOW TEMPERATURE HOSE

**RECOMMENDED FOR:**

High pressure hydraulic oil lines in applications where low temperature environmental conditions exist.

**PERFORMANCE:**

Meets or Exceeds the Performance Requirements of:  
AS 3791 100R2AT, DIN 20022-2SN, EN 853 Type 2SN,  
ISO 1436 Types R2AT & 2SN, SAE 100R2AT.

**TUBE:**

Black, specially formulated oil resistant synthetic rubber.

**REINFORCEMENT:**

Two braids of high tensile steel wire.

**COVER:**

Black, oil resistant and abrasion resistant synthetic rubber.  
No skiving required with T2000 Series Crimp Couplings.

**FEATURES:**

Low Temperature hose (-60°C/-76°F).

**TEMPERATURE RANGE:**

From -60°C to +100°C (-76°F to +212°F).

For water, emulsions etc. see page 58.

**WORKING PRESSURE:**

Maximum working pressures are based on 4:1 safety factor  
(maximum working pressure to minimum burst pressure).

**THIRD PARTY APPROVALS:**

ABS, DNV-GL, LR, MED, USCG, GOST-R, BV, RINA and KR.

**COUPLINGS:**
**NON-SKIVE ONE-PIECE CRIMP**

**T2000 Series** (sizes -04 to -32) pages 187 to 232.

Assembly Instructions pages 478.

T2C LOW TEMPERATURE HOSE															
PART NO	HOSE SIZE	NOMINAL HOSE ID		NOMINAL HOSE OD		MAXIMUM WORKING PRESSURE		MINIMUM BURST PRESSURE		MINIMUM BEND RADIUS		AVERAGE WEIGHT		COUPLING SERIES ONE PIECE	
Hose	DN	Dash	mm	inch	mm	inch	bar	psi	bar	psi	mm	inch	kg/m	lb/ft	NON-SKIVE
T24C	6	-04	6,6	1/4	15,0	0.59	420	6100	1680	24400	100	3.9	0,38	0.26	T2000
T25C	8	-05	8,2	5/16	16,6	0.65	350	5100	1400	20400	114	4.5	0,46	0.31	T2000
T26C	10	-06	9,8	3/8	19,0	0.75	350	5100	1400	20400	125	5.0	0,56	0.38	T2000
T28C	12	-08	13,0	1/2	22,2	0.87	350	5100	1400	20400	178	7.0	0,65	0.44	T2000
T210C	16	-10	16,2	5/8	25,2	0.99	250	3600	1000	14400	200	7.9	0.80	0.54	T2000
T212C	19	-12	19,1	3/4	29,1	1.15	215	3100	860	12400	240	9.5	0,94	0.63	T2000
T216C	25	-16	25,4	1	37,2	1.46	175	2500	700	10000	300	11.8	1,31	0.88	T2000
T220C	31	-20	31,8	1.1/4	47,4	1.87	140	2000	560	8000	420	16.5	1,91	1.28	T2000
T224C	38	-24	38,1	1.1/2	53,8	2.12	100	1450	400	5800	500	19.7	2,14	1.44	T2000
T232C	51	-32	50,8	2	66,7	2.63	90	1300	360	5200	600	23.6	2,78	1.87	T2000

Refer to the latest RYCO Crimp Charts for crimp diameter and mark lengths.

# HOSE

## BRAID

### TXA2D

EXTRA ABRASION RESISTANT  
EXTRA HIGH PRESSURE  
FRAS  
TWO WIRE BRAID HOSE



#### RECOMMENDED FOR:

High pressure hydraulic oil lines in applications where the outside cover of the hose is subjected to abrasion that may cause premature failure of standard hoses. Ideal for high pressure use that requires a smaller outside diameter (except -20 size), lighter weight, and more flexibility than spiral hose.

#### PERFORMANCE:

Meets or Exceeds the Performance Requirements of: AS 3791 100R2AT, BCS 174, DIN 20022-2SN, EN 853 Type 2SN, ISO 1436 Types R2AT & 2SN, SAE 100R2AT.

#### TUBE:

Black, oil resistant synthetic rubber.

#### REINFORCEMENT:

Two braids of high tensile steel wire.

#### COVER:

**DIEHARD™** Black, oil and extra abrasion resistant synthetic rubber. Flame Resistant, Anti-Static (FRAS) & MSHA compliant. Highly visible layline branding for easy and permanent identification. No skiving required with T2000 & T7000 Series Crimp Couplings and L000 Series Field Attachable Couplings.

#### FEATURES:

The very high abrasion resistant properties of the cover, combined with the high working pressures and excellent impulse life, when tested to EN 853 Type 2SN/SAE 100R2AT test conditions, result in increased service life and minimise equipment downtime.

#### FLAME RESISTANCE:

Complies with Flame Resistant and Electrical Resistance (Anti-Static) requirements of Australian Standard AS 2660 and Methods of Test AS 1180.10B and 13A. Meets Flame Resistant Designation "U.S. MSHA" of the US Department of Labor, Mine Safety and Health Administration.

#### TEMPERATURE RANGE:

From -40°C to +100°C (-40°F to +212°F).  
For water, emulsions etc. see page 58.

#### WORKING PRESSURE:

Maximum working pressures are based on 4:1 safety factor (maximum working pressure to minimum burst pressure).

#### THIRD PARTY APPROVALS:

ABS, DNV-GL, LR, MED, USCG, GOST-R, BV, RINA and KR.

#### COUPLINGS:

##### NON-SKIVE ONE-PIECE CRIMP

**T2000 Series** (sizes -08 to -16) pages 187 to 232.

**T7000 Series** (sizes -08 to -16) pages 272 to 302.

Assembly Instructions pages 478.

##### FIELD ATTACHABLE NON-SKIVE

**6000 SERIES** insert (sizes -08 to -16) pages 250 to 271.

**L000 Series** ferrule (sizes -08 to -16) page 353.

Assembly Instructions page 476.

TXA2D – DIEHARD AGGRESSOR NON-SKIVE HOSE																	
PART NO	HOSE SIZE	NOMINAL HOSE ID		NOMINAL HOSE OD		MAXIMUM WORKING PRESSURE		MINIMUM BURST PRESSURE		MINIMUM BEND RADIUS		AVERAGE WEIGHT		ONE PIECE	FIELD ATT		
Hose	DN	Dash	mm	inch	mm	inch	bar	psi	bar	psi	mm	inch	kg/m	lb/ft	NON-SKIVE		
TXA28D	12	-08	13,0	1/2	22,0	0.87	375	5440	1500	21760	178	7.0	0,72	0.48	T2000	T7000	6000 (L000)
TXA210D	16	-10	16,2	5/8	25,2	0.99	350	5100	1400	20400	200	8.0	0,87	0.58	T2000	T7000	6000 (L000)
TXA212D	19	-12	19,1	3/4	29,1	1.15	313	4530	1252	18120	240	9.5	1,11	0.75	T2000	T7000	6000 (L000)
TXA216D	25	-16	25,4	1	37,7	1.48	225	3250	900	13000	300	12.0	1,50	1.01	T2000	T7000	6000 (L000)

Contact RYCO for Crimp Diameter and Mark Length for BITELOK Couplings.

# H12D

EXTRA ABRASION RESISTANT  
VERY HIGH PRESSURE  
FRAS  
MULTI-SPIRAL HOSE



INTRODUCTION

HOSE

COUPLINGS

ADAPTORS

TECHNICAL

### RECOMMENDED FOR:

Very high pressure hydraulic oil lines, in applications where the outside cover of the hose is subject to abrasion that may cause premature failure of standard hoses.

### PERFORMANCE:

Meets or Exceeds the Performance Requirements of:  
AS 3791 100R12, EN 856 Type R12, EN 856 Type 4SP (-12 and above), ISO 3862 Type R12, SAE 100R12.

### TUBE:

Black, oil resistant synthetic rubber.

### REINFORCEMENT:

Four alternating layers of spiralled high tensile steel wire.

### COVER:

**DIEHARD™** Black, oil and extra abrasion resistant synthetic rubber. Flame Resistant, Anti-Static (FRAS) & MSHA compliant. Highly visible layline branding for easy and permanent identification. No skiving required with T7000 Series Crimp Couplings.

### FEATURES:

The very high abrasion resistant properties of the cover, combined with the extra high working pressures and excellent impulse life, when tested to SAE 100R12 test conditions, result in increased service life and minimise equipment downtime.

### FRAS - FLAME RESISTANCE AND ANTI-STATIC:

**DIEHARD™** complies with Flame Resistant and Electrical Resistance (Anti-Static) requirements of Australian Standard AS 2660 and Methods of Test AS 1180.10B and 13A. Meets Flame Resistant Designation "U.S. MSHA" of the US Department of Labor, Mine Safety and Health Administration.

### TEMPERATURE RANGE:

From -40°C to +121°C (-40°F to +250°F).  
For water, emulsions etc. see page 58.

### WORKING PRESSURE:

Maximum working pressures are based on 4:1 safety factor (maximum working pressure to minimum burst pressure).

### THIRD PARTY APPROVALS:

ABS, DNV-GL, LR, MED, USCG, GOST-R, BV, RINA and KR.

### COUPLINGS:

#### NON-SKIVE ONE-PIECE CRIMP

**T7000 Series** (sizes -06 to -40) pages 272 to 302.  
Assembly Instructions pages 478.

H12D - DIEHARD SPIRAL HOSE															
PART NO	HOSE SIZE	NOMINAL HOSE ID		NOMINAL HOSE OD		MAXIMUM WORKING PRESSURE		MINIMUM BURST PRESSURE		MINIMUM BEND RADIUS		AVERAGE WEIGHT		COUPLING SERIES ONE PIECE	
Hose	DN	Dash	mm	inch	mm	inch	bar	psi	bar	psi	mm	inch	kg/m	lb/ft	NON-SKIVE
H1206D	10	-06	9,5	3/8	19,3	0.76	350	5100	1400	20400	125	5.0	0,61	0.41	T7000
H1208D	12	-08	12,7	1/2	22,7	0.89	350	5100	1400	20400	178	7.0	0,78	0.52	T7000
H1210D	16	-10	15,9	5/8	26,2	1.03	350	5100	1400	20400	200	7.9	0,98	0.66	T7000
H1212D	19	-12	19,1	3/4	30,0	1.18	350	5100	1400	20400	240	9.5	1,21	0.81	T7000
H1216D	25	-16	25,4	1	37,4	1.47	350	5100	1400	20400	300	11.8	1,84	1.24	T7000
H1220D	31	-20	31,8	1.1/4	45,7	1.80	275	4000	1100	16000	400	15.8	2,34	1.57	T7000
H1224D	38	-24	38,1	1.1/2	53,0	2.09	255	3700	1020	14800	500	19.7	3,04	2.04	T7000
H1232D	51	-32	50,8	2	66,0	2.60	210	3050	840	12400	600	23.6	4,23	2.84	T7000
H1240D	63	-40	63,5	2.1/2	82,6	3.25	140	2000	560	8000	650	25.6	5,20	3.49	T7000

Refer to the latest RYCO Crimp Charts for crimp diameter and mark lengths.

# H12S

**EXTREMELY ABRASION RESISTANT  
VERY HIGH PRESSURE  
MULTI-SPIRAL HOSE**



### RECOMMENDED FOR:

Very high pressure hydraulic oil lines, in applications where the outside cover of the hose is subject to sliding abrasion that may cause premature failure of standard hoses.

### PERFORMANCE:

Meets or Exceeds the Performance Requirements of: AS 3791 100R12, EN 856 Type R12, EN 856 Type 4SP (-12 and above), ISO 3862 Type R12, SAE 100R12.

### TUBE:

Black, oil resistant synthetic rubber.

### REINFORCEMENT:

Four alternating layers of spiralled high tensile steel wire.

### COVER:

**SLIDER** Black, oil and extremely abrasion resistant synthetic rubber sheathed with a layer of extremely abrasion resistant polyethylene. Flame Resistant, MSHA compliant. Highly visible layline branding for easy and permanent identification. No skiving required with T7000 Series Crimp Couplings.

### FEATURES:

The extremely high abrasion resistant properties of the polyethylene sheathed cover, combined with the extra high working pressures and excellent impulse life, when tested to SAE 100R12 test conditions, result in increased service life and minimise equipment downtime.

### MSHA - FLAME RESISTANCE:

**SLIDER** complies with Flame Resistant requirements of Australian Standard AS 2660 and Methods of Test AS 1180.10B. Meets Flame Resistant Designation "U.S. MSHA" of the US Department of Labor, Mine Safety and Health Administration.

### TEMPERATURE RANGE:

From -40°C to +121°C (-40°F to +250°F).  
For water, emulsions etc. see page 58.

### WORKING PRESSURE:

Maximum working pressures are based on 4:1 safety factor (maximum working pressure to minimum burst pressure).

### THIRD PARTY APPROVALS:

ABS, DNV-GL, LR, MED, USCG, GOST-R, BV, RINA and KR.

### COUPLINGS:

#### NON-SKIVE ONE-PIECE CRIMP

**T7000 Series** (sizes -06 to -32) pages 272 to 302.  
Assembly Instructions pages 478.

H12S - SLIDER SPIRAL HOSE															
PART NO	HOSE SIZE	NOMINAL HOSE ID		NOMINAL HOSE OD		MAXIMUM WORKING PRESSURE		MINIMUM BURST PRESSURE		MINIMUM BEND RADIUS		AVERAGE WEIGHT		COUPLING SERIES	
		mm	inch	mm	inch	bar	psi	bar	psi	mm	inch	kg/m	lb/ft	ONE PIECE	
<b>H1206S</b>	10 -06	9,5	3/8	19,3	0.76	350	5100	1400	20400	125	5.0	0,61	0.41	NON-SKIVE T7000	
<b>H1208S</b>	12 -08	12,7	1/2	22,7	0.89	350	5100	1400	20400	178	7.0	0,78	0.52	T7000	
<b>H1210S</b>	16 -10	15,9	5/8	26,2	1.03	350	5100	1400	20400	200	7.9	0,98	0.66	T7000	
<b>H1212S</b>	19 -12	19,1	3/4	30,0	1.18	350	5100	1400	20400	240	9.5	1,21	0.81	T7000	
<b>H1216S</b>	25 -16	25,4	1	37,4	1.47	350	5100	1400	20400	300	11.8	1,84	1.24	T7000	
<b>H1220S</b>	31 -20	31,8	1.1/4	45,7	1.80	275	4000	1100	16000	400	15.8	2,34	1.57	T7000	
<b>H1224S</b>	38 -24	38,1	1.1/2	53,0	2.09	255	3700	1020	14800	500	19.7	3,04	2.04	T7000	
<b>H1232S</b>	51 -32	50,8	2	66,0	2.60	210	3050	840	12400	600	23.6	4,23	2.84	T7000	

Refer to the latest RYCO Crimp Charts for crimp diameter and mark lengths.



# R4SPD

EXTRA HIGH PRESSURE  
FOUR SPIRAL HOSE



INTRODUCTION

HOSE

COUPLINGS

ADAPTORS

TECHNICAL

### RECOMMENDED FOR:

Extra high pressure hydraulic oil lines.

### PERFORMANCE:

Meets or Exceeds the Performance Requirements of:  
EN 856 Type 4SP, ISO 3862 Type 4SP.

### TUBE:

Black, oil resistant synthetic rubber.

### REINFORCEMENT:

Four alternating layers of spiralled high tensile steel wire.

### COVER:

**DIEHARD™** Black, oil and extra abrasion resistant synthetic rubber. Flame Resistant, Anti-Static (FRAS) & MSHA compliant. Extra thin cover suitable for non-skive and skive couplings. Highly visible layline branding for easy and permanent identification. No skiving required with T7000 Series Crimp Couplings.

### FRAS - FLAME RESISTANCE AND ANTI-STATIC:

**DIEHARD™** complies with Flame Resistant and Electrical Resistance (Anti-Static) requirements of Australian Standard AS 2660 and Methods of Test AS 1180.10B and 13A. Meets Flame Resistant Designation "U.S. MSHA" of the US Department of Labor, Mine Safety and Health Administration.

### TEMPERATURE RANGE:

From -40°C to +100°C (-40°F to +212°F).

For water, emulsions etc. see page 58.

### WORKING PRESSURE:

Maximum working pressures are based on 4:1 safety factor (maximum working pressure to minimum burst pressure).

### THIRD PARTY APPROVALS:

ABS, DNV-GL, LR, MED, USCG, GOST-R, BV, RINA, KR & MA-KA.

### COUPLINGS:

#### NON-SKIVE ONE-PIECE CRIMP

**T7000 Series** (sizes -06 to -16) pages 272 to 302.

Assembly Instructions pages 478.

R4SPD - DIEHARD SPIRAL HOSE															
PART NO	HOSE SIZE	NOMINAL HOSE ID		NOMINAL HOSE OD		MAXIMUM WORKING PRESSURE		MINIMUM BURST PRESSURE		MINIMUM BEND RADIUS		AVERAGE WEIGHT		COUPLING SERIES	
Hose	DN	Dash	mm	inch	mm	inch	bar	psi	bar	psi	mm	inch	kg/m	lb/ft	NON-SKIVE
R4SP08D	12	-08	12,7	1/2	23,5	0.93	420	6100	1680	24400	230	9.1	0,86	0.58	T7000
R4SP10D	16	-10	15,9	5/8	27,0	1.06	380	5500	1520	22000	250	9.9	1,10	0.74	T7000
R4SP12D	19	-12	19,1	3/4	31,0	1.22	380	5500	1520	22000	300	11.8	1,47	0.99	T7000
R4SP16D	25	-16	25,4	1	37,8	1.49	350	5100	1400	20400	340	13.4	1,95	1.31	T7000

Refer to the latest RYCO Crimp Charts for crimp diameter and mark lengths.

# HOSE

## SPIRAL

### R4SHD

EXTRA HIGH PRESSURE  
FOUR SPIRAL HOSE

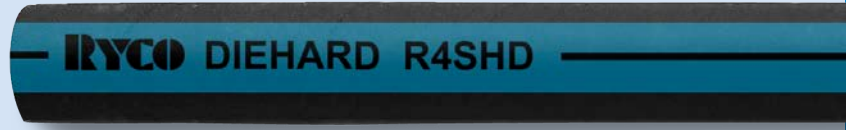

**RECOMMENDED FOR:**

Extra high pressure hydraulic oil lines.

**PERFORMANCE:**

Meets or Exceeds the Performance Requirements of:  
EN 856 Type 4SH, ISO 3862 Type 4SH.

**TUBE:**

Black, oil resistant synthetic rubber.

**REINFORCEMENT:**

Four alternating layers of spiralled high tensile steel wire.

**COVER:**

**DIEHARD™** Black, oil and extra abrasion resistant synthetic rubber. Flame Resistant, Anti-Static (FRAS) & MSHA compliant. Extra thin cover suitable for non-skive and skive couplings. Highly visible layline branding for easy and permanent identification. No skiving required with T6000 and T7000 Series Crimp Couplings.

**FRAS - FLAME RESISTANCE AND ANTI-STATIC:**

**DIEHARD™** complies with Flame Resistant and Electrical Resistance (Anti-Static) requirements of Australian Standard AS 2660 and Methods of Test AS 1180.10B and 13A. Meets Flame Resistant Designation "U.S. MSHA" of the US Department of Labor, Mine Safety and Health Administration.

**TEMPERATURE RANGE:**

From -40°C to +100°C (-40°F to +212°F).  
For water, emulsions etc. see page 58.

**WORKING PRESSURE:**

Maximum working pressures are based on 4:1 safety factor (maximum working pressure to minimum burst pressure).

**THIRD PARTY APPROVALS:**

ABS, DNV-GL, LR, MED, USCG, GOST-R, BV, RINA, KR & MA-KA.

**COUPLINGS:**

**NON-SKIVE ONE-PIECE CRIMP**

**T6000 SERIES** (size -12) pages 250 to 271.

**T7000 Series** (sizes -16 to -32) pages 272 to 302.  
Assembly Instructions pages 478.

R4SHD - DIEHARD SPIRAL HOSE															
PART NO	HOSE SIZE	NOMINAL HOSE ID		NOMINAL HOSE OD		MAXIMUM WORKING PRESSURE		MINIMUM BURST PRESSURE		MINIMUM BEND RADIUS		AVERAGE WEIGHT		COUPLING SERIES	
		mm	inch	mm	inch	bar	psi	bar	psi	mm	inch	kg/m	lb/ft	ONE PIECE	
R4SH12D	19 -12	19,1	3/4	31,8	1.25	420	6100	1680	24400	280	11.0	1,47	0.99	T6000	
R4SH16D	25 -16	25,4	1	37,9	1.49	380	5500	1520	22000	340	13.4	1,97	1.32		T7000
R4SH20D	31 -20	31,8	1.1/4	44,4	1.75	350	5100	1400	20400	460	18.1	2,44	1.64		T7000
R4SH24D	38 -24	38,1	1.1/2	51,8	2.04	300	4350	1200	17400	560	22.1	3,13	2.10		T7000

Refer to the latest RYCO Crimp Charts for crimp diameter and mark lengths.

## JACK HOSE ASSEMBLIES

For ease of ordering, Hose Assemblies can be specified using TJ24 and TJ26 numbers below, followed by overall length in millimetres.

For example, to order a TJ24D Hose Assembly, 1800 mm overall length, with 3/8" NPTF male one end and male Screw-On coupling other end, with Spring Guards at each end; simply order TJ2402-1800.

Standard lengths are 1000 mm, 2000 mm and 3000 mm. Other lengths are available.

**JACK HOSE ASSEMBLIES (HOSE ENDS INCLUDE RYCO 750 SPRING GUARD\*\*)**

HOSE ASSEMBLY No.	HOSE END 1	HOSE END 2
TJ2401-xxxx* TJ2601-xxxx*	3/8" NPTF Male	3/8" NPTF Male
TJ2402-xxxx* TJ2602-xxxx*	3/8" NPTF Male	R100-06M Male Tip
TJ2403-xxxx* TJ2603-xxxx*	3/8" NPTF Male	R100-06M Male Tip and R100-06DC Dust Cap
TJ2404-xxxx* TJ2604-xxxx*	3/8" NPTF Male	R100-06FM Male and Female Coupling
TJ2405-xxxx* TJ2605-xxxx*	3/8" NPTF Male	R100-06FMPC Male and Female Coupling with Dust Cap and Dust Plug

\* Substitute xxxx for overall length (mm)

\*\* RYCO 750 Spring Guard is only available to suit TJ24D hose assemblies.

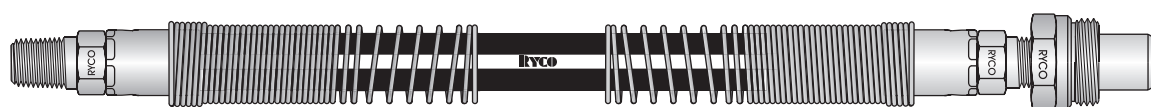

TJ2402 shown

### R100 SERIES QUICK RELEASE COUPLINGS, 700 BAR/10,000 PSI, THREAD-TO-CONNECT.

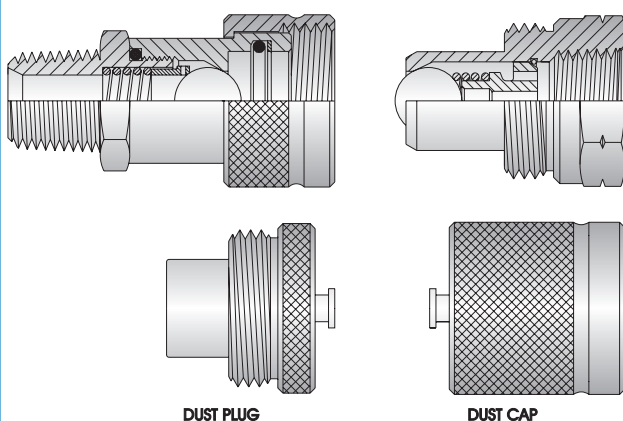

DUST PLUG

DUST CAP

- Designed for use in heavy duty applications on portable cylinders, rams and pumps, where low flow rates and pressures up to 700 bar/10,000 psi are involved.
- Threaded sleeve on female body engages thread on male tip.  
When the sleeve is screwed completely up, the two coupling halves are secured together. Can connect and disconnect with pressure in line.
- Precision ball type check valves.
- Threaded dust caps and plugs complete with captive chain are available.
- Female body is NPTF male threaded to screw directly into the cylinder or ram.
- Male tip is NPTF female threaded to screw onto hose coupling.

NOMINAL SIZE	NPTF THREAD	MAXIMUM WORKING PRESSURE		FEMALE BODY	MALE TIP	COMPLETE COUPLING	DUST PLUG FOR MALE	DUST PLUG FOR FEMALE
		bar	psi					
1/4	1/4	700	10000	R100-04F	R100-04M	R100-04FM	R100-06DP	R100-06DC
3/8	3/8	700	10000	R100-06F	R100-06M	R100-06FM	R100-06DP	R100-06DC

For further information refer to Quick Release Couplings (QRC) Brochure on [www.RYCO.com.au](http://www.RYCO.com.au).

# HOSE

## SPECIALTY AND HIGH TEMPERATURE

### TJ2D

EXTRA ABRASION RESISTANT  
FRAS  
JACK HOSE  
TWO WIRE BRAID



#### RECOMMENDED FOR:

Hydraulic Jack applications requiring a light weight, small outside diameter hose. The very high abrasion resistant properties of the DIEHARD cover extend the life of the hose when it is subjected to the abrasion that may cause the premature failure of standard hoses.

#### PERFORMANCE:

Meets or Exceeds the Performance Requirements of: Materials Handling Institute specification IJ 100 (July 1979) for hydraulic hose and assemblies used with jacking systems.

#### TUBE:

Black, oil resistant synthetic rubber.

#### REINFORCEMENT:

Two braids of high tensile steel wire.

#### COVER:

**DIEHARD™** Black, oil and extra abrasion resistant synthetic rubber. Flame Resistant, Anti-Static (FRAS) & MSHA compliant. Highly visible layline branding for easy and permanent identification. No skiving required with T2000 Series Crimp Couplings.

#### FRAS - FLAME RESISTANCE AND ANTI-STATIC:

**DIEHARD™** complies with Flame Resistant and Electrical Resistance (Anti-Static) requirements of Australian Standard AS 2660 and Methods of Test AS 1180.10B and 13A. Meets Flame Resistant Designation "U.S. MSHA" of the US Department of Labor, Mine Safety and Health Administration.

#### TEMPERATURE RANGE:

From -40°C to +49°C (-40°F to +120°F).  
For water, emulsions etc. see page 58.

#### WORKING PRESSURE:

Specification IJ 100 (July 1979) is based on 2:1 minimum burst to maximum working pressure safety factor and is suitable for 700 bar/10,000 psi use in hydraulic jack applications ONLY.

#### COUPLINGS:

##### NON-SKIVE ONE-PIECE CRIMP

**T2000 Series** (sizes -04 to -06) pages 187 to 232.  
Assembly Instructions pages 478.

TJ2D - DIEHARD JACK HOSE															
PART NO	HOSE SIZE	NOMINAL HOSE ID		NOMINAL HOSE OD		MAXIMUM WORKING PRESSURE		MINIMUM BURST PRESSURE		MINIMUM BEND RADIUS		AVERAGE WEIGHT		COUPLING SERIES	
Hose	DN	Dash	mm	inch	mm	inch	bar	psi	bar	psi	mm	inch	kg/m	lb/ft	NON-SKIVE
TJ24D	6	-04	6,6	1/4	14.9	0.59	700	10000	1400	20000	100	3.9	0.35	0.24	T2000
TJ26D	10	-06	9,8	3/8	18.9	0.74	700	10000	1400	20000	130	5.0	0.51	0.34	T2000

**NOTE:** Ensure rated Working Pressure of chosen End Style meets or exceeds the 700 bar/10,000 psi Maximum Working Pressure of TJ2D hose.

For hydraulic jack applications, RYCO recommends the use of 3/8" NPTF Male Extended Couplings.

**TJ24D:** Part No. T2091-0406 One-Piece Crimp. Use of RYCO 750 Spring Guards at each end of the hose assembly is also recommended.

**TJ26D:** Part No. T2091-0606 One-Piece Crimp. Use of a Bend Restrictor device at each end of the hose assembly is also recommended.

Refer to the latest RYCO Crimp Charts for crimp diameter and mark lengths.



# RQP1

HIGH TEMPERATURE  
MULTI FLUID  
ONE WIRE BRAID HOSE



**RECOMMENDED FOR:**

High pressure hydraulic oil applications where pressure or temperature requirements exceed the performance requirements of SAE 100R1AT and DIN 20022-1SN. May be used with compressed air if cover of hose is perforated (pin-pricked) and additional Safety Devices are used.

**PERFORMANCE:**

Meets or Exceeds the Performance Requirements of: AS 3791 100R1AT, DIN 20022-1SN, EN 853 Type 1SN, ISO 1436 Types R1AT & 1SN, SAE 100R1AT.

**TUBE:**

Black, synthetic rubber, specifically compounded for temperature resistance and multi fluid resistance.

**REINFORCEMENT:**

One braid of high tensile steel wire.

**COVER:**

Survivor, blue, oil resistant and abrasion resistant synthetic rubber.

No skiving required with T2000 Series Crimp Couplings and K000 Series Field Attachable Couplings\*.

**MSHA - FLAME RESISTANCE:**

Meets Flame Resistant Designation "U.S. MSHA" of the US Department of Labor, Mine Safety and Health Administration. Complies with Flame Resistant requirements of Australian Standard AS 2660 and Method of Test AS 1180.10B.

**TEMPERATURE RANGE:**

From -40°C to +150°C (-40°F to +302°F).

For water, water/oil emulsions, diesel fuels, glycol, see page 58.

**WORKING PRESSURE:**

Maximum working pressures are based on 4:1 safety factor (maximum working pressure to minimum burst pressure).

**THIRD PARTY APPROVALS:**

ABS, DNV-GL, LR, MED, USCG, GOST-R, BV, RINA and KR.

**COUPLINGS:**

**NON-SKIVE ONE-PIECE CRIMP**

**T2000 Series** (sizes -04 to -16) pages 187 to 232. Assembly Instructions pages 478.

**FIELD ATTACHABLE NON-SKIVE\***

**6000 SERIES** insert (sizes -04 to -16) pages 250 to 271.

**K000 Series** ferrule (sizes -04 to -16) page 353.

Assembly Instructions page 476.

RQP1 - SURVIVOR NON-SKIVE HOSE																
PART NO	HOSE SIZE	NOMINAL HOSE ID		NOMINAL HOSE OD		MAXIMUM WORKING PRESSURE		MINIMUM BURST PRESSURE		MINIMUM BEND RADIUS		AVERAGE WEIGHT		ONE PIECE	FIELD ATT	
Hose	DN	Dash	mm	inch	mm	inch	bar	psi	bar	psi	mm	inch	kg/m	lb/ft	NON-SKIVE	
RQP14	6	-04	6,6	1/4	13,4	0.53	225	3250	900	13000	100	4.0	0,24	0.16	T2000	6000 (K000)
RQP15	8	-05	8,2	5/16	15,0	0.59	215	3120	860	12500	114	4.5	0,27	0.18	T2000	
RQP16	10	-06	9,8	3/8	17,4	0.69	180	2600	720	10400	125	5.0	0,34	0.23	T2000	6000 (K000)
RQP18	12	-08	13,0	1/2	20,5	0.81	160	2300	640	9300	178	7.0	0,44	0.30	T2000	6000 (K000)
RQP110	16	-10	16,2	5/8	23,7	0.93	130	1880	520	7540	200	8.0	0,51	0.34	T2000	6000 (K000)
RQP112	19	-12	19,1	3/4	27,6	1.09	120	1740	480	7000	240	9.5	0,64	0.43	T2000	6000 (K000)
RQP116	25	-16	25,4	1	35,7	1.41	90	1300	360	5200	300	12.0	0,98	0.66	T2000	6000 (K000)

\* Field Attachable Couplings should not be used on RQP1 Hose at maximum working pressure when temperature exceeds 121°C (250°F). Field Attachable Couplings may be used on RQP1 Hose at over 121°C but at reduced working pressure. Contact RYCO for more information. Refer to the latest RYCO Crimp Charts for crimp diameter and mark lengths.

# HOSE

## SPECIALTY AND HIGH TEMPERATURE

### RQP2

HIGH TEMPERATURE  
MULTI FLUID  
TWO WIRE BRAID HOSE

**RYCO SURVIVOR RQP2**



#### RECOMMENDED FOR:

High pressure hydraulic oil applications where pressure or temperature requirements exceed the performance requirements of SAE 100R2AT, DIN 20022-2SN and EN 853 Type 2SN. May be used with compressed air if cover of hose is perforated (pin-pricked) and additional Safety Devices are used.

#### PERFORMANCE:

Meets or Exceeds the Performance Requirements of: AS 3791 100R2AT, DIN 20022-2SN, EN 853 Type 2SN, ISO 1436 Types R2AT & 2SN, SAE 100R2AT.

#### TUBE:

Survivor, black, synthetic rubber, specifically compounded for temperature resistance and multi fluid resistance.

#### REINFORCEMENT:

Two braids of high tensile steel wire.

#### COVER:

Blue, oil resistant and abrasion resistant synthetic rubber. No skiving required with T2000 & T7000 Series Crimp Couplings and L000 Series Field Attachable Couplings\*.

#### MSHA - FLAME RESISTANCE:

Meets Flame Resistant Designation "U.S. MSHA" of the US Department of Labor, Mine Safety & Health Administration. Complies with Flame Resistant requirements of Australian Standard AS 2660 & Method of Test AS 1180.10B.

#### TEMPERATURE RANGE:

From -40°C to +150°C (-40°F to +302°F).  
See page 58.

#### WORKING PRESSURE:

Maximum working pressures are based on 4:1 safety factor (maximum working pressure to minimum burst pressure).

#### THIRD PARTY APPROVALS:

ABS, DNV-GL, LR, MED, USCG, GOST-R, BV, RINA and KR.

#### COUPLINGS:

##### NON-SKIVE ONE-PIECE CRIMP

**T2000 Series** (sizes -04 to -32) pages 187 to 232.

**T7000 Series** (sizes -06 to -32) pages 272 to 302.  
Assembly Instructions pages 478.

##### FIELD ATTACHABLE NON-SKIVE\*

**6000 SERIES** insert (sizes -04 to -20) pages 250 to 271.

**L000 Series** ferrule (sizes -04 to -20) page 353.  
Assembly Instructions page 476.

RQP2 - SURVIVOR NON-SKIVE HOSE																	
PART NO	HOSE SIZE	NOMINAL HOSE ID		NOMINAL HOSE OD		MAXIMUM WORKING PRESSURE		MINIMUM BURST PRESSURE		MINIMUM BEND RADIUS		AVERAGE WEIGHT		ONE PIECE	FIELD ATT		
Hose	DN	Dash	mm	inch	mm	inch	bar	psi	bar	psi	mm	inch	kg/m	lb/ft	NON-SKIVE		
RQP24	6	-04	6,6	1/4	15,0	0.59	400	5800	1600	23200	100	3.9	0,39	0.26	T2000		6000 (L000)
RQP25	8	-05	8,2	5/16	16,6	0.65	350	5100	1400	20400	114	4.5	0,45	0.30	T2000		
RQP26	10	-06	9,8	3/8	19,0	0.75	350	5100	1400	20400	125	5.0	0,53	0.36	T2000	T7000	6000 (L000)
RQP28	12	-08	13,0	1/2	22,0	0.87	300	4350	1200	17400	178	7.0	0,65	0.44	T2000	T7000	6000 (L000)
RQP210	16	-10	16,2	5/8	25,2	0.99	250	3600	1000	14500	200	8.0	0,77	0.52	T2000	T7000	6000 (L000)
RQP212	19	-12	19,1	3/4	29,1	1.15	215	3100	860	12400	240	9.5	0,93	0.62	T2000	T7000	6000 (L000)
RQP216	25	-16	25,4	1	37,7	1.48	167	2400	670	9600	300	11.8	1,38	0.93	T2000	T7000	6000 (L000)
RQP220	31	-20	31,8	1.1/4	48,0	1.89	150	2175	600	8700	420	16.5	2,03	1.36	T2000	T7000	6000 (L000)
RQP224	38	-24	38,1	1.1/2	54,4	2.14	100	1450	400	5800	500	19.7	2,30	1.55	T2000	T7000	
RQP232	51	-32	50,8	2	67,3	2.65	90	1300	360	5200	600	23.6	3,16	2.12	T2000	T7000	

\* Field Attachable Couplings should not be used on RQP2 Hose at maximum working pressure when temperature exceeds 121°C (250°F). Field Attachable Couplings may be used on RQP2 Hose at over 121°C but at reduced working pressure. Contact RYCO Hydraulics for more information. Refer to the latest RYCO Crimp Charts for crimp diameter and mark lengths.

# RQP5

HIGH TEMPERATURE  
POLYESTER BRAID COVER  
ONE WIRE BRAID HOSE

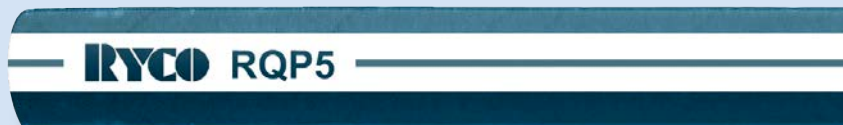

INTRODUCTION

**RECOMMENDED FOR:**

Medium to high pressure hydraulic oil applications. The small bend radius, temperature resistance and light weight of RYCO RQP5 hose make it suitable for under the bonnet automotive/trucking applications including hydraulic oil, diesel fuel, lubrication oil and transmission oil coolers. Sizes RQP54 to RQP512 also comply with SAE J1402 Type All "Automotive Air Brake Hose" for use in truck "air brake systems including flexible connections from frame to axle, tractor to trailer, trailer to trailer, and other unshielded air lines that are exposed to potential pull or impact". RQP5 may be used with compressed air if maximum working pressure is reduced by 30%. RQP5 hose is normally used where there is minimal abrasion to the outside cover. If abrasion is likely, support the hose away from the source of abrasion using mounting clamps, or protect with RWA Wire Armour or RSG Spiral Guard. RQP5 is a reduced bore hose. It has a similar Inside Diameter to steel or copper tubing of the same nominal (Outside Diameter) size. See page 340 for Branding Information.

**PERFORMANCE:**

Meets or Exceeds the Performance Requirements of: AS 3791 100R5, SAE 100R5, SAE J1402 Type All (up to -12 size).

**TUBE:**

Black, oil resistant synthetic rubber.

**REINFORCEMENT:**

Polyester inner braid covered with one braid of high tensile steel wire.

**COVER:**

Blue polyester textile braid. Skiving of cover is not required.

**MSHA - FLAME RESISTANCE:**

Meets Flame Resistant Designation "U.S. MSHA" of the US Department of Labor, Mine Safety and Health Administration and Flame Resistant requirements of Australian Standard AS 2660 and Method of Test AS 1180.10B when used with FS1072 Fire Sleeve.

**TEMPERATURE RANGE:**

From -40°C to +150°C (-40°F to +302°F).  
See page 58.

**WORKING PRESSURE:**

Maximum working pressures are based on 4:1 safety factor (maximum working pressure to minimum burst pressure).

**THIRD PARTY APPROVALS:**

ABS, DNV-GL, LR, MED, USCG, DOT, GOST-R, BV, RINA and KR.

**COUPLINGS:**

**NON-SKIVE ONE-PIECE CRIMP**

**T4000 Series** (Sizes -04 to -20) pages 233 to 249.  
Assembly Instructions pages 478.

**FIELD ATTACHABLE NON-SKIVE**

**V000 Series** (sizes -04 to -32) pages 341 to 352.  
Assembly Instructions page 476.

HOSE

COUPLINGS

ADAPTORS

TECHNICAL

RQP5 - SURVIVOR POLYESTER COVER HOSE																				
PART NO	HOSE SIZE	NOMINAL HOSE ID		NOMINAL HOSE OD		MAXIMUM WORKING PRESSURE		MINIMUM BURST PRESSURE		MINIMUM BEND R SAE100R5		MINIMUM BEND R SAEJ1402		VACUUM RATING		AVERAGE WEIGHT		ONE PC	FIELD	
Hose	DN	Dash	mm	inch	mm	inch	bar	psi	bar	psi	mm	inch	mm	inch	inHg	mmHg	kg/m	lb/ft	NON-SKIVE	
RQP54	5	-04	4,8	3/16	13,2	0.52	210	3050	840	12200	75	3.0	51	2.0	0,23	0.15	710	28	T4000	V000
RQP55	6	-05	6,4	1/4	14,8	0.58	210	3050	840	12200	85	3.3	64	2.5	0,26	0.17	710	28	T4000	V000
RQP56	8	-06	7,9	5/16	17,2	0.68	157	2250	628	9000	100	4.0	76	3.0	0,30	0.20	710	28	T4000	V000
RQP58	10	-08	10,3	13/32	19,4	0.76	140	2000	560	8000	115	4.6	89	3.5	0,36	0.24	710	28	T4000	V000
RQP510	12	-10	12,7	1/2	23,4	0.92	122	1750	488	7000	140	5.5	102	4.0	0,53	0.36	710	28	T4000	V000
RQP512	16	-12	15,9	5/8	27,4	1.08	105	1500	420	6000	165	6.5	114	4.5	0,65	0.44	710	28	T4000	V000
RQP516	22	-16	22,2	7/8	31,4	1.24	56	800	224	3200	185	7.4			0,63	0.42	510	20	T4000	V000
RQP520	28	-20	31,0	1.1/8	38,1	1.50	43	625	172	2500	230	9.0			0,90	0.60	510	20	T4000	V000
RQP524	35	-24	32,0	1.3/8	44,5	1.75	35	500	140	2000	265	10.5			1,00	0.67	380	15	T4000	V000
RQP532	46	-32	45,0	1.13/16	56,3	2.22	24	350	98	1400	335	13.3			1,48	0.99	280	11	T4000	V000

**\*IMPORTANT NOTE:** MAXIMUM WORKING PRESSURE and MINIMUM BURST PRESSURE shown above relate to SAE 100R5 specification and hose used in non Air Brake applications. For Air Brake applications, SAE J1402 Type All Air Brake Hose specification requires Minimum Burst Pressure 900 psi (62,1 bar) and Proof Pressure of 300 psi (20,7 bar) for all sizes, and reduced Minimum Bend Radii as shown below. RQP54 to RQP512 comply with SAE J1402 Minimum Bend Radius at SAE J1402 pressures, and SAE 100R5 Minimum Bend Radius at SAE 100R5 working pressures. Refer to the latest RYCO Crimp Charts for crimp diameter and mark lengths.

# HOSE

## SPECIALTY AND HIGH TEMPERATURE

### RQP6 HIGH TEMPERATURE ONE TEXTILE BRAID HOSE



#### RECOMMENDED FOR:

Hydraulic oil lines, transmission oil cooler lines, glycol antifreeze solutions, water, diesel fuels and air.

#### PERFORMANCE:

Meets or Exceeds the Performance Requirements of: AS 3791 100R6, DIN 20021-1TE, ISO 4079 Type 1, SAE 100R6.

#### TUBE:

Black, oil resistant synthetic rubber.

#### REINFORCEMENT:

One textile braid.

#### COVER:

Blue, oil resistant and abrasion resistant synthetic rubber.

#### MSHA - FLAME RESISTANCE:

Meets Flame Resistance Designation "U.S. MSHA" of the US Department of Labor, Mine Safety and Health Administration. Complies with Flame Resistant requirement of Australian Standard AS 2660 and Method of Test AS 1180.10B.

#### TEMPERATURE RANGE:

##### Petroleum base hydraulic oils & transmission oils:

-40°C to +135°C (-40°F to +275°F) constant, and up to +150°C (+302°F) intermittent (up to 10% of operating time).

**Air:** -40°C to +100°C (-40°F to +212°F)

**Diesel fuels:** -40°C to +71°C (-40°F to +160°F).

For water, emulsions etc. see page 58.

#### WORKING PRESSURE:

Maximum working pressures are based on 4:1 safety factor (maximum working pressure to minimum burst pressure).

RQP6 Hose, and 8000 Series Push-On Fittings, are recommended for use in systems with Static Working Pressures (constant loads without pressure spikes) only. They are not recommended for vibration or pressure surge applications. RQP6 Hose should not be used at both maximum working pressure and maximum temperature simultaneously.

#### COUPLINGS:

##### NON-SKIVE ONE-PIECE CRIMP

**T4000 Series** (Sizes -04 to -12) pages 233 to 249. Assembly Instructions pages 478.

##### 8000 SERIES PUSH-ON

RQP6 Hose simply pushes on to 8000 Series Couplings, and for Static Working Pressures up to 50% of Maximum Static Working Pressures a clamp is not required. For diesel fuel and other potentially dangerous, or critical applications such as transmission oil cooler lines, and for Static Working Pressures above 50% of maximum; a clamp around the hose is required. Do not overtighten clamp as this will damage hose. Factory crimped couplings are also available in some sizes.

RQP6 - SURVIVOR HIGH TEMPERATURE PUSH ON HOSE																		
PART NO	HOSE SIZE	NOMINAL HOSE ID		NOMINAL HOSE OD		MAXIMUM WORKING PRESSURE		MINIMUM BURST PRESSURE		MINIMUM BEND RADIUS		VACUUM RATING		AVERAGE WEIGHT		ONE PC	PUSH ON	
Hose	DN	Dash	mm	inch	mm	inch	bar	psi	bar	psi	mm	inch	inHg	mmHg	kg/m	lb/ft	NON-SKIVE	
RQP64	6	-04	6,6	1/4	12,3	0.48	28	410	112	1640	65	2.5	710	28	0,12	0.08	T4000	8000
RQP65	8	-05	8,2	5/16	13,9	0.55	28	410	112	1640	75	3.0	710	28	0,14	0.09	T4000	8000
RQP66	10	-06	9,8	3/8	15,5	0.61	28	410	112	1640	75	3.0	635	25	0,17	0.11	T4000	8000
RQP68	12	-08	13,0	1/2	19,0	0.75	28	410	112	1640	100	4.0	460	18	0,22	0.15	T4000	8000
RQP610	16	-10	16,2	5/8	22,6	0.89	24	350	96	1400	125	5.0	380	15	0,29	0.19	T4000	8000
RQP612	20	-12	19,1	3/4	25,8	1.02	21	305	84	1220	150	6.0	380	15	0,34	0.23	T4000	8000

Refer to the latest RYCO Crimp Charts for crimp diameter and mark lengths.



# D2B

DRILLER  
HIGH TEMPERATURE  
DRILL RIG HOSE



**RECOMMENDED FOR:**

Hydraulic oil or air lines. Drill rigs - high pressure, large bore air hose.

**PERFORMANCE:**  
SAE 100R16 (SIZE -20).

**TUBE:**  
Black, oil resistant synthetic rubber specifically compounded for temperature resistance.

**REINFORCEMENT:**  
Two braids of high tensile steel wire.

**COVER:**  
Perforated blue, oil and abrasion resistant synthetic rubber. No skiving required with T2000 & T7000 Series Crimp Couplings.

**MSHA - FLAME RESISTANCE:**

Complies with Flame Resistant requirements of Australian Standard AS 2660 and Method of Test AS 1180.10B. Meets Flame Resistant Designation "U.S. MSHA" of the US Department of Labor, Mine Safety and Health Administration.

**TEMPERATURE RANGE:**  
Air: -40°C to +121°C (-40°F to +250°F)  
Oil: -40°C to +135°C (-40°F to +275°F)

**WORKING PRESSURE:**  
Maximum working pressures are based on 4:1 safety factor (maximum working pressure to minimum burst pressure).

**THIRD PARTY APPROVALS:**  
ABS, DNV-GL, LR, MED, USCG, GOST-R, BV, RINA and KR.

**COUPLINGS:**  
NON-SKIVE ONE-PIECE CRIMP

**T2000 Series** (sizes -20 to -32) pages 187 to 232.  
**T7000 Series** (sizes -24 to -32) pages 272 to 302.  
Assembly Instructions pages 478.

Not suitable for use with field attachable couplings. Refer to Product Technical Manual - Hydraulics for assembly instructions.

INTRODUCTION

HOSE

COUPLINGS

ADAPTORS

TECHNICAL

D2B - DRILLER HOSE		NOMINAL HOSE ID		NOMINAL HOSE OD		MAXIMUM WORKING PRESSURE		MINIMUM BURST PRESSURE		MINIMUM BEND RADIUS		AVERAGE WEIGHT		COUPLING SERIES	
PART NO	HOSE SIZE	mm	inch	mm	inch	bar	psi	bar	psi	mm	inch	kg/m	lb/ft	ONE PIECE	
<b>D220B</b>	31 -20	31,8	1.1/4	40,4	1.59	140	2030	560	8120	200	7.9	1,22	0.82	NON-SKIVE	
<b>D224B</b>	38 -24	38,1	1.1/2	48,0	1.89	100	1450	400	5800	250	9.8	1,49	1.00	T2000	T7000
<b>D232B</b>	51 -32	50,8	2	62,0	2.44	90	1300	360	5200	300	11.8	2,24	1.50	T2000	T7000

Refer to the latest RYCO Crimp Charts for crimp diameter and mark lengths.

# HOSE

## SPECIALTY AND HIGH TEMPERATURE

### T5

POLYESTER BRAID COVER  
ONE WIRE BRAID HOSE



#### RECOMMENDED FOR:

Medium to high pressure hydraulic oil applications. The small bend radius, temperature resistance and light weight of RYCO T5 hose make it suitable for under the bonnet automotive/trucking applications including hydraulic oil, diesel fuel, lubrication oil and transmission oil coolers. Sizes T54 to T512 also comply with SAE J1402 Type All "Automotive Air Brake Hose" for use in truck "air brake systems including flexible connections from frame to axle, tractor to trailer, trailer to trailer, and other unshielded air lines that are exposed to potential pull or impact". T5 may be used with compressed air if maximum working pressure is reduced by 30%. T5 hose is normally used where there is minimal abrasion to the outside cover. If abrasion is likely, support the hose away from the source of abrasion using mounting clamps, or protect with RWA Wire Armour or RSG Spiral Guard. T5 is a reduced bore hose. It has a similar Inside Diameter to steel or copper tubing of the same nominal (outside diameter) size. See page 151 for more information.

#### PERFORMANCE:

Meets or Exceeds the Performance Requirements of: AS 3791 100R5, SAE 100R5, SAE J1402 Type All (up to -12 size).

#### TUBE:

Black, oil resistant synthetic rubber.

#### REINFORCEMENT:

Polyester inner braid covered with one braid of high tensile steel wire.

#### COVER:

Black polyester braid. Skiving of cover is not required.

#### MSHA - FLAME RESISTANCE:

Meets Flame Resistant Designation "U.S. MSHA" of the US Department of Labor, Mine Safety and Health Administration and Flame Resistant requirements of Australian Standard AS 2660 and Method of Test AS 1180.10B when used with FS1072 Fire Sleeve.

#### TEMPERATURE RANGE:

From -40°C to +100°C (-40°F to +212°F).  
For water, emulsions etc. see page 58.

#### WORKING PRESSURE:

Maximum working pressures are based on 4:1 safety factor (maximum working pressure to minimum burst pressure).

#### THIRD PARTY APPROVALS:

ABS, DNV-GL, LR, MED, USCG, DOT, GOST-R, BV, RINA and KR.

#### COUPLINGS:

##### NON-SKIVE ONE-PIECE CRIMP

**T4000 Series** (Sizes -04 to -20) pages 233 to 249.  
Assembly Instructions pages 478.

##### FIELD ATTACHABLE NON-SKIVE

**V000 Series** (sizes -04 to -32) pages 341 to 352.  
Assembly Instructions page 476.

T5 - TRUCKER POLYESTER COVER HOSE																				
PART NO	HOSE SIZE	NOMINAL HOSE ID		NOMINAL HOSE OD		MAXIMUM WORKING PRESSURE		MINIMUM BURST PRESSURE		MINIMUM BEND R SAE100R5		MINIMUM BEND R SAEJ1402		VACUUM RATING		AVERAGE WEIGHT		ONE PC	FIELD ATT	
Hose	DN	Dash	mm	inch	mm	inch	bar	psi	bar	psi	mm	inch	mm	inch	inHg	mmHg	kg/m	lb/ft	NON-SKIVE	
T54	5	-04	4,8	3/16	13,2	0.52	210	3050	840	12200	75	3.0	51	2.0	710	28	0,23	0.15	T4000	V000
T55	6	-05	6,4	1/4	14,8	0.58	210	3050	840	12200	85	3.3	64	2.5	710	28	0,26	0.17	T4000	V000
T56	8	-06	7,9	5/16	17,2	0.68	157	2250	628	9000	100	4.0	76	3.0	710	28	0,30	0.20	T4000	V000
T58	10	-08	10,3	13/32	19,4	0.76	140	2000	560	8000	115	4.6	89	3.5	710	28	0,36	0.24	T4000	V000
T510	12	-10	12,7	1/2	23,4	0.92	122	1750	488	7000	140	5.5	102	4.0	710	28	0,53	0.36	T4000	V000
T512	16	-12	15,9	5/8	27,4	1.08	105	1500	420	6000	165	6.5	114	4.5	710	28	0,65	0.44	T4000	V000
T516	22	-16	22,2	7/8	31,4	1.24	56	800	224	3200	187	7.4			510	20	0,63	0.42	T4000	V000
T520	28	-20	31,0	1.1/8	38,1	1.50	43	625	172	2500	229	9.0			510	20	0,90	0.60	T4000	V000
T524	35	-24	32,0	1.3/8	44,5	1.75	35	500	140	2000	267	10.5			380	15	1,00	0.67	T4000	V000
T532	46	-32	45,0	1.13/16	56,3	2.22	24	350	96	1400	337	13.3			280	11	1,48	0.99	T4000	V000

**\*IMPORTANT NOTE:** MAXIMUM WORKING PRESSURE and MINIMUM BURST PRESSURE shown above relate to SAE 100R5 specification and hose used in non Air Brake applications. For Air Brake applications, SAE J1402 Type All Air Brake Hose specification requires Minimum Burst Pressure 900 psi (62,1 bar) and Proof Pressure of 300 psi (20,7 bar) for all sizes, and reduced Minimum Bend Radii as shown below. T54 to T512 comply with SAE J1402 Minimum Bend Radius at SAE J1402 pressures, and SAE 100R5 Minimum Bend Radius at SAE 100R5 working pressures. Refer to the latest RYCO Crimp Charts for crimp diameter and mark lengths.

# MS1000

MINESPRAY



INTRODUCTION

HOSE

COUPLINGS

ADAPTORS

TECHNICAL

**RECOMMENDED FOR:**

Water and air spray suited for dust control in all industrial and mining applications.

**TUBE:**

Black, oil resistant synthetic rubber.

Cover is perforated (pin-pricked).

**REINFORCEMENT:**

One braid of high tensile steel wire.

**COVER:**

Yellow, oil resistant and abrasion resistant synthetic rubber.

No skiving required with T2000 Series Crimp Couplings.

**MSHA - FLAME RESISTANCE:**

Complies with Flame Resistant requirements of Australian Standard AS 2660 and Method of Test AS 1180.10B. Meets Flame Resistant Designation "U.S. MSHA" of the US Department of Labor, Mine Safety and Health Administration.

**TEMPERATURE RANGE:**

From -40°C to +100°C (-40°F to +212°F).

For water, emulsions etc. see page 58.







**WORKING PRESSURE:**

Maximum working pressures are based on 4:1 safety factor (maximum working pressure to minimum burst pressure).

**COUPLINGS:**
**NON-SKIVE ONE-PIECE CRIMP**

**T2000 Series** (sizes -08 to -32) pages 187 to 232.

Assembly Instructions pages 478.

CS1000 - MINESPRAY HOSE															
PART NO	HOSE SIZE	NOMINAL HOSE ID		NOMINAL HOSE OD		MAXIMUM WORKING PRESSURE		MINIMUM BURST PRESSURE		MINIMUM BEND RADIUS		AVERAGE WEIGHT		COUPLING SERIES ONE PIECE	
Hose	DN	Dash	mm	inch	mm	inch	bar	psi	bar	psi	mm	inch	kg/m	lb/ft	NON-SKIVE
MS1008	12	-08	13,0	1/2	18,5	0.73	70	1000	280	4000	90	3.6	0,29	0.19	T2000
MS1010	16	-10	16,2	5/8	22,1	0.87	70	1000	280	4000	100	3.9	0,35	0.24	T2000
MS1012	19	-12	19,1	3/4	25,8	1.02	70	1000	280	4000	120	4.7	0,40	0.27	T2000
MS1016	25	-16	25,4	1	32,5	1.28	70	1000	280	4000	150	5.9	0,62	0.42	T2000
MS1020	31	-20	31,8	1.1/4	39,5	1.56	70	1000	280	4000	210	8.3	0,75	0.50	T2000
MS1024	38	-24	38,1	1.1/2	46,0	1.81	70	1000	280	4000	250	9.9	1,00	0.67	T2000
MS1032	51	-32	50,8	2	59,1	2.33	70	1000	280	4000	300	11.8	1,42	0.95	T2000

Refer to the latest RYCO Crimp Charts for crimp diameter and mark lengths.

# HOSE

## SPECIALTY AND HIGH TEMPERATURE

### CS1000

COALSPRAY



#### RECOMMENDED FOR:

Water and air spray suited for dust control in all industrial and mining applications.

#### TUBE:

Black, oil resistant synthetic rubber.  
Cover is perforated (pin-pricked).

#### REINFORCEMENT:

One braid of high tensile steel wire.

#### COVER:

Black, oil resistant and abrasion resistant synthetic rubber.  
No skiving required with T2000 Series Crimp Couplings.

#### FRAS - FLAME RESISTANCE AND ANTI-STATIC:

Complies with Flame Resistant and Electrical Resistance (Anti-Static) requirements of Australian Standard AS 2660 and Methods of Test AS 1180.10B and 13A. Meets Flame Resistant Designation "U.S. MSHA" of the US Department of Labor, Mine Safety and Health Administration.

#### TEMPERATURE RANGE:

From -40°C to +100°C (-40°F to +212°F).  
For water, emulsions etc. see page 58.

#### WORKING PRESSURE:

Maximum working pressures are based on 4:1 safety factor (maximum working pressure to minimum burst pressure).

#### COUPLINGS:

##### NON-SKIVE ONE-PIECE CRIMP

**T2000 Series** (sizes -04 to -32) pages 187 to 232.  
For water, emulsions etc. see page 58.

CS1000 - COALSPRAY HOSE															
PART NO	HOSE SIZE	NOMINAL HOSE ID		NOMINAL HOSE OD		MAXIMUM WORKING PRESSURE		MINIMUM BURST PRESSURE		MINIMUM BEND RADIUS		AVERAGE WEIGHT		COUPLING SERIES ONE PIECE	
Hose	DN	Dash	mm	inch	mm	inch	bar	psi	bar	psi	mm	inch	kg/m	lb/ft	NON-SKIVE
CS1008	12	-08	13,0	1/2	18,5	0.73	70	1000	280	4000	90	3.6	0,29	0.19	T2000
CS1010	16	-10	16,2	5/8	22,1	0.87	70	1000	280	4000	100	3.9	0,35	0.24	T2000
CS1012	19	-12	19,1	3/4	25,8	1.02	70	1000	280	4000	120	4.7	0,40	0.27	T2000
CS1016	25	-16	25,4	1	32,5	1.28	70	1000	280	4000	150	5.9	0,62	0.42	T2000
CS1020	31	-20	31,8	1.1/4	39,5	1.56	70	1000	280	4000	210	8.3	0,75	0.50	T2000
CS1024	38	-24	38,1	1.1/2	46,0	1.81	70	1000	280	4000	250	9.9	1,00	0.67	T2000
CS1032	51	-32	50,8	2	59,1	2.33	70	1000	280	4000	300	11.8	1,42	0.95	T2000

Refer to the latest RYCO Crimp Charts for crimp diameter and mark lengths.





# BIOTRANS

TRANSPORTING OUR FUTURE

WIDE RANGE OF FLUIDS

MULTI PURPOSE HOSE



MSHA

# HOSE

## SPECIALTY AND HIGH TEMPERATURE

### BT1

ONE WIRE BRAID HOSE



#### RECOMMENDED FOR:

Transportation, marine fuel and engine hose applications. Low pressure hydraulic oil return lines, general purpose water, glycol antifreeze solutions, biodiesel, diesel fuel, ethanol, gasoline/ petrol or air.

#### PERFORMANCE:

Meets or Exceeds the Performance Requirements of: SAE J1527 Type Class I, USCG SAE J1942, SAE J30R2 (non-marine). Meets SAE J30R2 performance requirements for non-marine applications and SAE J1527 Type Class I and USCG SAEJ1942 for marine applications.

#### TUBE:

Black, oil resistant synthetic rubber.

#### REINFORCEMENT:

One braid of high tensile steel wire.

#### COVER:

Blue, oil resistant and abrasion resistant synthetic rubber.

#### MSHA - FLAME RESISTANCE:

Complies with Flame Resistant requirements of Australian Standard AS 2660 and Method of Test AS 1180.10B. Meets Flame Resistant Designation "U.S. MSHA" of the US Department of Labor, Mine Safety and Health Administration.

#### WORKING PRESSURE:

Maximum working pressures are based on 4:1 safety factor (maximum working pressure to minimum burst pressure).

#### TEMPERATURE RANGE:

MEDIA	TEMP °C	
	MIN	MAX
Petroleum based hydraulic fluids	-40	+135
Water, water/oil emulsion and water/glycol hydraulic fluids	—	80
Engine oil, lubricating oils	-40	121
Air	—	70
Diesel, JP8	-20	100
Biodiesel	-40	100
Gasoline/petrol	-20	80
Ethanol blends (15% max.ethanol)	-20	80

#### THIRD PARTY APPROVALS:

ABS, DNV-GL, LR, MED, USCG, DOT, GOST-R, BV, RINA and KR.

#### COUPLINGS:

##### NON-SKIVE ONE-PIECE CRIMP

**T2000 Series** (sizes -04 to -16) pages 187 to 232. Assembly Instructions pages 478.

##### FIELD ATTACHABLE NON-SKIVE

**6000 SERIES** insert (sizes -04 to -16) pages 250 to 271.

**K000 Series** ferrule (sizes -04 to -16) page 353. Assembly Instructions page 476.

BT1 - BIOTRANS HOSE		NOMINAL HOSE ID		NOMINAL HOSE OD		MAXIMUM WORKING PRESSURE		MINIMUM BURST PRESSURE		MINIMUM BEND RADIUS		AVERAGE WEIGHT		COUPLING SERIES		
PART NO	HOSE SIZE	mm	inch	mm	inch	bar	psi	bar	psi	mm	inch	kg/m	lb/ft	ONE PC	FIELD ATT	
<b>BT14</b>	6	-04	6,6	1/4	13,3	0.52	50	725	200	2900	25	1.0	0,22	0.15	T2000	6000 (K000)
<b>BT15</b>	8	-05	8,2	5/16	14,9	0.59	50	725	200	2900	30	1.2	0,25	0.17	T2000	
<b>BT16</b>	10	-06	9,8	3/8	17,3	0.68	50	725	200	2900	35	1.4	0,31	0.21	T2000	6000 (K000)
<b>BT18</b>	12	-08	13,0	1/2	20,3	0.80	50	725	200	2900	55	2.2	0,39	0.26	T2000	6000 (K000)
<b>BT110</b>	16	-10	16,2	5/8	23,6	0.93	50	725	200	2900	70	2.8	0,49	0.33	T2000	6000 (K000)
<b>BT112</b>	19	-12	19,1	3/4	27,6	1.09	50	725	200	2900	80	3.2	0,62	0.41	T2000	6000 (K000)
<b>BT116</b>	25	-16	25,4	1	35,5	1.40	50	725	200	2900	105	4.1	0,90	0.60	T2000	6000 (K000)

Refer to the latest RYCO Crimp Charts for crimp diameter and mark lengths.





## SW

### VERY HIGH PRESSURE WATERBLAST

#### RECOMMENDED FOR:

Very High Pressure waterblast hose for the cleaning and preparation of marine surfaces, runway and swimming pool cleaning, and paint removal.

**DO NOT USE with Steam.**

#### TUBE:

Oil and water resistant synthetic rubber.

#### REINFORCEMENT:

Four alternating layers of spiralled high tensile steel wire.

#### COVER:

Oil, water and ozone resistant synthetic rubber. The cover is formulated to resist marking. Internal and External skiving required with TW4000 Series Interlok Crimp Couplings.

#### FEATURES:

Exceeds ISO 7751 performance requirements.  
Meets specifications EN 1829-2 (impulse) and AS/NZS 4233.2.  
Highly abrasion resistant cover.

#### TEMPERATURE RANGE:

Continuous service from -20°C to +80°C (-4°F to +176°F).  
Intermittent service to +100°C (+212°F).

#### WORKING PRESSURE:

Maximum working pressures are based on 2.5:1 safety factor (maximum working pressure to minimum burst pressure).

#### COUPLINGS:

##### INTERLOK SKIVE ONE-PIECE CRIMP

**TW4000 Series** (Sizes -06 to -16) page 323.  
Assembly Instructions page 479

#### A MEMBER OF

THE WATERJET TECHNOLOGY ASSOCIATION (WJTA) AND  
INDUSTRIAL & MUNICIPAL CLEANING ASSOCIATION (IMCA)

THE AUSTRALASIAN HIGH PRESSURE WATER JETTING  
ASSOCIATION

SW SHOCKWAVE - VERY HIGH PRESSURE HOSE																
COLOUR CODE	PART NO	HOSE SIZE	NOMINAL HOSE ID		NOMINAL HOSE OD		MAXIMUM WORKING PRESSURE		MINIMUM BURST PRESSURE		MINIMUM BEND RADIUS		AVERAGE WEIGHT		INTERLOK ONE-PIECE	
	Hose	DN Dash	mm	inch	mm	inch	bar	psi	bar	psi	mm	inch	kg/m	lb/ft	INT/EXT SKIVE	
	SW18006	10 -06	9,5	3/8	21,5	0.85	1250	18125	3125	45315	150	5.9	0,56	0.37	TW4000	
	SW16008	12 -08	12,7	1/2	24,6	0.97	1100	16000	2750	40000	180	7.1	0,83	0.56	TW4000	
	SW14512	19 -12	19,0	3/4	31,9	1.26	1000	14500	2500	36250	220	8.7	0,92	0.62	TW4000	
	SW10012	19 -12	19,0	3/4	30,6	1.21	700	10000	1750	25000	220	8.7	1,34	0.90	TW4000	
	SW10016	25 -16	25,4	1	37,6	1.48	700	10000	1750	25000	250	9.8	1,39	0.93	TW4000	

Cutting and Assembly Charges apply to all RYCO hoses, and vary by hose types and sizes. Contact RYCO for additional information or visit [www.RYCO.com.au](http://www.RYCO.com.au)

WJTA-IMCA colour code recommendations:	
	20K Pressure Range
	15K Pressure Range
	10K Pressure Range

# HOSE

## PRESSURE WASHER

### JS4000/G

PRESSURE WASHER  
280 BAR/4100 PSI

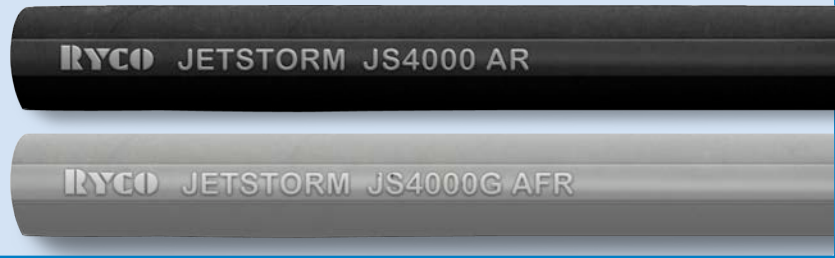

#### RECOMMENDED FOR:

Hot Water Pressure Washer Machines.

**DO NOT USE with Steam.**

#### PERFORMANCE:

Meets or Exceeds the Performance Requirements of:  
EN 1829-2.

#### TUBE:

Black, heat resistant synthetic rubber.

#### REINFORCEMENT:

One braid of high tensile steel wire.

#### COVER:

Oil resistant synthetic rubber formulated to resist marking.

JS4000, black, highly abrasion resistant (AR), non marking.

JS4000G, grey, animal fat resistant (AFR), non marking.

Embossed layline for positive, permanent identification.

No skiving required for T2000 Series Crimp Couplings.

#### TEMPERATURE RANGE:

JS4000/G JETSTORM Hoses handle hot water up to  
+135°C (+275°F) with intermittent service to  
+150°C (+302°F).

#### WORKING PRESSURE:

Maximum working pressures are based on 3:1 safety factor  
(maximum working pressure to minimum burst pressure).

#### COUPLINGS:

##### NON-SKIVE ONE-PIECE CRIMP

**T2000 Series** (sizes -04 to -08) pages 187 to 232.

Assembly Instructions pages 478.

#### A MEMBER OF

THE WATERJET TECHNOLOGY ASSOCIATION (WJTA) AND  
INDUSTRIAL & MUNICIPAL CLEANING ASSOCIATION (IMCA)

THE AUSTRALASIAN HIGH PRESSURE WATER JETTING  
ASSOCIATION

JS4000 JETSTORM - PRESSURE WASHER HOSE															
PART NO	HOSE SIZE	NOMINAL HOSE ID		NOMINAL HOSE OD		MAXIMUM WORKING PRESSURE		MINIMUM BURST PRESSURE		MINIMUM BEND RADIUS		AVERAGE WEIGHT		ONE PIECE	
Hose	DN	Dash	mm	inch	mm	inch	bar	psi	bar	psi	mm	inch	kg/m	lb/ft	NON-SKIVE
JS4004/G	6	-04	6,6	1/4	11,5	0.45	280	4100	840	12300	50	2.0	0,15	0.10	T2000
JS4005/G	8	-05	8,2	5/16	13,1	0.52	280	4100	840	12300	55	2.2	0,18	0.12	T2000
JS4006/G	10	-06	9,8	3/8	15,3	0.60	280	4100	840	12300	65	2.6	0,23	0.15	T2000
JS4008/G	12	-08	13,0	1/2	18,3	0.72	280	4100	840	12300	90	3.6	0,31	0.21	T2000

Cutting and Assembly Charges apply to all RYCO industrial hoses, and vary by hose types and sizes. Contact RYCO for additional information or visit [www.RYCO.com.au](http://www.RYCO.com.au)





# JS4000BX/GX

PRESSURE WASHER  
280 BAR/4100 PSI

**RECOMMENDED FOR:**

Hot Water Pressure Washer Machines.  
**DO NOT USE with Steam.**

**PERFORMANCE:**

Meets or Exceeds the Performance Requirements of:  
EN 1829-2.

**TUBE:**

Black, heat resistant synthetic rubber.

**REINFORCEMENT:**

One braid of high tensile steel wire.

**COVER:**

Oil resistant synthetic rubber formulated to resist marking  
JS4000BX, blue, highly abrasion resistant (AR), non marking  
JS4000GX, grey, highly abrasion resistant (AR), non marking.  
Embossed layline for positive, permanent identification.  
No skiving required for T2000 Series Crimp Couplings.

**TEMPERATURE RANGE:**

JS4000BX/GX JETSTORM Hoses handle hot water up to  
+135°C (+275°F) with intermittent service to  
+150°C (+302°F).

**WORKING PRESSURE:**

Maximum working pressures are based on 3:1 safety factor  
(maximum working pressure to minimum burst pressure).

**COUPLINGS:**

**NON-SKIVE ONE-PIECE CRIMP**

**T2000 Series** (sizes -04 to -08) pages 187 to 232.  
Assembly Instructions pages 478.

**A MEMBER OF**

THE WATERJET TECHNOLOGY ASSOCIATION (WJTA) AND  
INDUSTRIAL & MUNICIPAL CLEANING ASSOCIATION (IMCA)  
THE AUSTRALASIAN HIGH PRESSURE WATER JETTING  
ASSOCIATION

JS4000 JETSTORM - PRESSURE WASHER HOSE															
PART NO	HOSE SIZE	NOMINAL HOSE ID		NOMINAL HOSE OD		MAXIMUM WORKING PRESSURE		MINIMUM BURST PRESSURE		MINIMUM BEND RADIUS		AVERAGE WEIGHT		ONE PIECE	
Hose	DN	Dash	mm	inch	mm	inch	bar	psi	bar	psi	mm	inch	kg/m	lb/ft	NON-SKIVE
JS4004BX	6	-04	6,6	1/4	12,6	0.50	280	4100	840	12300	50	2.0	0,18	0.12	T2000
JS4005BX	8	-05	8,2	5/16	14,2	0.56	280	4100	840	12300	55	2.2	0,22	0.15	T2000
JS4006BX	10	-06	9,8	3/8	16,4	0.65	280	4100	840	12300	65	2.6	0,26	0.17	T2000
JS4008BX	12	-08	13,0	1/2	19,4	0.76	280	4100	840	12300	90	3.6	0,36	0.24	T2000
JS4004GX	6	-04	6,6	1/4	12,6	0.50	280	4100	840	12300	50	2.0	0,18	0.12	T2000
JS4005GX	8	-05	8,2	5/16	14,2	0.56	280	4100	840	12300	55	2.2	0,22	0.15	T2000
JS4006GX	10	-06	9,8	3/8	16,4	0.65	280	4100	840	12300	65	2.6	0,26	0.17	T2000
JS4008GX	12	-08	13,0	1/2	19,4	0.76	280	4100	840	12300	90	3.6	0,36	0.24	T2000

Cutting and Assembly Charges apply to all RYCO industrial hoses, and vary by hose types and sizes. Contact RYCO for additional information or visit [www.RYCO.com.au](http://www.RYCO.com.au)

# HOSE

## PRESSURE WASHER

### JS6000/G

PRESSURE WASHER  
420 BAR/6100 PSI



#### RECOMMENDED FOR:

Hot Water Pressure Washer Machines.

**DO NOT USE with Steam.**

#### PERFORMANCE:

Meets or Exceeds the Performance Requirements of:  
EN 1829-2.

#### TUBE:

Black, heat resistant synthetic rubber.

#### REINFORCEMENT:

Two braid of high tensile steel wire.

#### COVER:

Oil resistant synthetic rubber formulated to resist marking.

JS6000, black, highly abrasion resistant (AR), non marking  
JS6000G, grey, animal fat resistant (AFR), non marking.

Embossed layline for positive, permanent identification.

No skiving required for T2000 Series Crimp Couplings.

#### TEMPERATURE RANGE:

JS6000/G JETSTORM Hoses handle hot water up to  
+135°C (+275°F) with intermittent service to  
+150°C (+302°F).

#### WORKING PRESSURE:

Maximum working pressures are based on 3:1 safety factor  
(maximum working pressure to minimum burst pressure).

#### COUPLINGS:

##### NON-SKIVE ONE-PIECE CRIMP

**T2000 Series** (sizes -04 to -08) pages 187 to 232.

Assembly Instructions pages 478.

#### A MEMBER OF

THE WATERJET TECHNOLOGY ASSOCIATION (WJTA) AND  
INDUSTRIAL & MUNICIPAL CLEANING ASSOCIATION (IMCA)

THE AUSTRALASIAN HIGH PRESSURE WATER JETTING  
ASSOCIATION

JS6000 JETSTORM - PRESSURE WASHER HOSE															
PART NO	HOSE SIZE	NOMINAL HOSE ID	NOMINAL HOSE OD	MAXIMUM WORKING PRESSURE	MINIMUM BURST PRESSURE	MINIMUM BEND RADIUS	AVERAGE WEIGHT	COUPLING SERIES		ONE PIECE					
Hose	DN	Dash	mm	inch	mm	inch	bar	psi	bar	psi	mm	inch	kg/m	lb/ft	NON-SKIVE
JS6004/G	6	-04	6,6	1/4	12,4	0.49	420	6100	1260	18300	50	2.0	0,23	0.15	T2000
JS6005/G	8	-05	8,2	5/16	14,5	0.57	420	6100	1260	18300	55	2.2	0,30	0.20	T2000
JS6006/G	10	-06	9,8	3/8	16,3	0.64	420	6100	1260	18300	65	2.6	0,32	0.22	T2000
JS6008/G	12	-08	13,0	1/2	19,3	0.76	420	6100	1260	18300	90	3.6	0,44	0.30	T2000

Cutting and Assembly Charges apply to all RYCO industrial hoses, and vary by hose types and sizes. Contact RYCO for additional information or visit [www.RYCO.com.au](http://www.RYCO.com.au)



# JS6000BX/GX

PRESSURE WASHER  
420 BAR/6100 PSI

**RECOMMENDED FOR:**

Hot Water Pressure Washer Machines.

**DO NOT USE with Steam.**

**PERFORMANCE:**

Meets or Exceeds the Performance Requirements of:  
EN 1829-2.

**TUBE:**

Black, heat resistant synthetic rubber.

**REINFORCEMENT:**

Two braid of high tensile steel wire.

**COVER:**

Oil resistant synthetic rubber formulated to resist marking.  
JS6000BX, blue, highly abrasion resistant (AR), non marking.  
JS6000GX, grey, highly abrasion resistant (AR), non marking.  
Embossed layline for positive, permanent identification.  
No skiving required for T2000 Series Crimp Couplings.

**TEMPERATURE RANGE:**

JS6000BX/GX JETSTORM Hoses handle hot water up to  
+135°C (+275°F) with intermittent service to  
+150°C (+302°F).

**WORKING PRESSURE:**

Maximum working pressures are based on 3:1 safety factor  
(maximum working pressure to minimum burst pressure).

**COUPLINGS:**

**NON-SKIVE ONE-PIECE CRIMP**

**T2000 Series** (sizes -04 to -08) pages 187 to 232.  
Assembly Instructions pages 478.

**A MEMBER OF**

THE WATERJET TECHNOLOGY ASSOCIATION (WJTA) AND  
INDUSTRIAL & MUNICIPAL CLEANING ASSOCIATION (IMCA)  
THE AUSTRALASIAN HIGH PRESSURE WATER JETTING  
ASSOCIATION

JS6000 JETSTORM - PRESSURE WASHER HOSE															
PART NO	HOSE SIZE	NOMINAL HOSE ID		NOMINAL HOSE OD		MAXIMUM WORKING PRESSURE		MINIMUM BURST PRESSURE		MINIMUM BEND RADIUS		AVERAGE WEIGHT		ONE PIECE	
Hose	DN	Dash	mm	inch	mm	inch	bar	psi	bar	psi	mm	inch	kg/m	lb/ft	NON-SKIVE
JS6004BX	6	-04	6,6	1/4	13,5	0.53	420	6100	1260	18300	50	2.0	0,26	0.17	T2000
JS6005BX	8	-05	8,2	5/16	15,6	0.61	420	6100	1260	18300	55	2.2	0,34	0.23	T2000
JS6006BX	10	-06	9,8	3/8	17,4	0.69	420	6100	1260	18300	65	2.6	0,35	0.24	T2000
JS6008BX	12	-08	13,0	1/2	20,4	0.80	420	6100	1260	18300	90	3.6	0,49	0.33	T2000
JS6004GX	6	-04	6,6	1/4	13,5	0.53	420	6100	1260	18300	50	2.0	0,26	0.17	T2000
JS6005GX	8	-05	8,2	5/16	15,6	0.61	420	6100	1260	18300	55	2.2	0,34	0.23	T2000
JS6006GX	10	-06	9,8	3/8	17,4	0.69	420	6100	1260	18300	65	2.6	0,35	0.24	T2000
JS6008GX	12	-08	13,0	1/2	20,4	0.80	420	6100	1260	18300	90	3.6	0,49	0.33	T2000

Cutting and Assembly Charges apply to all RYCO industrial hoses, and vary by hose types and sizes. Contact RYCO for additional information or visit [www.RYCO.com.au](http://www.RYCO.com.au)

# HOSE

## SUCTION & RETURN

### SRF COMPACT SUCTION & RETURN HOSE



#### RECOMMENDED FOR:

Petroleum and water base hydraulic fluids in suction lines or in low pressure return lines. Small bend radius is an advantage in installations where space is minimal. (Tighter Bend Radius than SAE 100R4)

#### PERFORMANCE:

Meets or Exceeds the Performance Requirements of: AS 3791 100R4, SAE 100R4.

#### TUBE:

Black, oil resistant synthetic rubber.

#### REINFORCEMENT:

Textile reinforcement with spiral wire to prevent collapsing.

#### COVER:

Black, oil resistant and abrasion resistant synthetic rubber.

#### TEMPERATURE RANGE:

From -40°C to +100°C (-40°F to +212°F).  
For water, emulsions etc. see page 58.

#### WORKING PRESSURE:

Maximum working pressures are based on 4:1 safety factor (maximum working pressure to minimum burst pressure).

#### THIRD PARTY APPROVALS:

ABS, DNV-GL, LR, MED, USCG, DOT, GOST-R, BV, RINA and KR.

#### COUPLINGS:

Working pressure shown is for hose performance capabilities. Performance of a hose assembly depends on couplings used.

#### 1. For Suction Applications, and Low Pressure Delivery (up to 25% of Maximum Working Pressure).

#### 33000 SERIES COUPLINGS WITH RSC CLAMP

**33000 Series** (sizes -12 to -32) pages 334 to 338  
3300 Series Couplings require a suitable clamp around the outside of the hose. Refer to RYCO RSC Clamps shown below. Assembly instructions pages 481

#### 2. For Suction Applications, and High Pressure Delivery (up to 100% of Maximum Working Pressure).

#### NON-SKIVE ONE-PIECE CRIMP

**T4000 Series** (Sizes -12 to -32) pages 233 to 249.  
Assembly Instructions pages 478.

SRF - DEFIANT COMPACT SUCTION AND RETURN HOSE																
PART NO	HOSE SIZE	NOMINAL HOSE ID		NOMINAL HOSE OD		MAXIMUM WORKING PRESSURE		MINIMUM BURST PRESSURE		MINIMUM BEND RADIUS		VACUUM RATING		AVERAGE WEIGHT		
Hose	DN	Dash	mm	inch	mm	inch	bar	psi	bar	psi	mm	inch	mmHg	inHg	kg/m	lb/ft
SRF12	19	-12	19,1	3/4	31,5	1.24	21	300	84	1200	65	2.5	635	25	0,82	0.55
SRF16	25	-16	25,4	1	40,0	1.57	17	250	68	1000	75	2.9	635	25	1,00	0.67
SRF20	31	-20	31,8	1.1/4	46,5	1.83	14	200	56	800	100	3.9	635	25	1,19	0.80
SRF24	38	-24	38,1	1.1/2	53,1	2.09	11	150	42	600	125	4.9	635	25	1,39	0.93
SRF32	51	-32	50,8	2	65,5	2.58	7	100	28	400	150	5.9	635	25	1,94	1.30

HOSE PART NO	CLAMP PART NO	CLAMP ADJUSTMENT RANGE	RECOMMENDED TIGHTENING TORQUE	
		d mm	N.m	ft.lbf
SRF12	RSC-3134	31 to 34	20	15
SRF16	RSC-3740*	37 to 40	20	15
	RSC-4043*	40 to 43	20	15
SRF20	RSC-4347*	43 to 47	20	15
	RSC-4751*	47 to 51	20	15
SRF24	RSC-5155	51 to 55	20	15
SRF32	RSC-6368	63 to 68	25	18

**NOTE:** For sizes -20, -24 & -32, use RYCO SRF Hose.  
\*Due to the manufacturing tolerance on outside diameter of the hose and the range of adjustment of the clamp, it is necessary to confirm correct clamp at time of assembly.

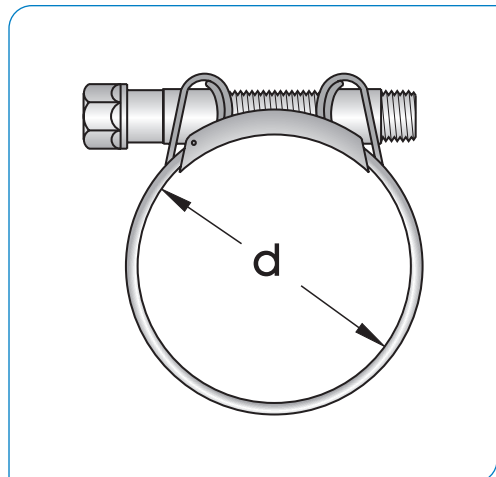



# SRX

**EXTREME FLEXIBILITY  
COMPACT  
SUCTION AND RETURN**

**RECOMMENDED FOR:**

Petroleum and water base hydraulic fluids in suction lines or in low pressure return lines. Extreme Flexibility is an advantage in installations where space is minimal.  
(Tighter Bend Radius than SAE 100R4)

**PERFORMANCE:**

Meets or Exceeds the Performance Requirements of: AS 3791 100R4, SAE 100R4.

**TUBE:**

Black, oil resistant synthetic rubber.

**REINFORCEMENT:**

Textile reinforcement with spiral wire to prevent collapsing.

**COVER:**

Black, oil resistant and abrasion resistant synthetic rubber.

**TEMPERATURE RANGE:**

From -40°C to +100°C (-40°F to +212°F)

**WORKING PRESSURE:**

Maximum working pressures are based on 4:1 safety factor (maximum working pressure to minimum burst pressure).

**THIRD PARTY APPROVALS:**

ABS, DNV-GL, LR, MED, USCG, DOT, GOST-R, BV, RINA and KR.

**COUPLINGS:**

**NON-SKIVE ONE-PIECE CRIMP**

**T4000 Series** (Sizes -12 to -48) pages 233 to 249. Assembly Instructions pages 478.

SRX- XTREME SUCTION AND RETURN HOSE																	
PART NO	HOSE SIZE	NOMINAL HOSE ID		NOMINAL HOSE OD		MAXIMUM WORKING PRESSURE		MINIMUM BURST PRESSURE		MINIMUM BEND RADIUS		VACUUM RATING		AVERAGE WEIGHT		ONE PIECE	
Hose	DN	Dash	mm	inch	mm	inch	bar	psi	bar	psi	mm	inch	mmHg	inHg	kg/m	lb/ft	NON-SKIVE
SRX12	19	-12	19,1	3/4	29.6	1.17	21	305	84	1,218	40	1.6	600	23	0,52	0.35	T4000
SRX16	25	-16	25,4	1	36.2	1.43	17	247	68	986	45	1.8	600	23	0,63	0.42	T4000
SRX20	31	-20	31,8	1.1/4	44.0	1.73	14	203	56	812	60	2.4	600	23	0,82	0.55	T4000
SRX24	38	-24	38,1	1.1/2	49.4	1.94	11	145	42	580	65	2.6	600	23	1,07	0.72	T4000
SRX32	51	-32	50,8	2	63.8	2.51	7	102	28	406	100	3.9	600	23	1,54	1.03	T4000
SRX40	63	-40	63,5	2.1/2	76.5	3.01	4	58	16	232	140	5.5	600	23	2,01	1.35	T4000
SRX48	76	-48	76,2	3	89.9	3.54	4	58	16	232	180	7.1	600	23	2,50	1.68	T4000

Refer to the latest RYCO Crimp Charts for crimp diameter and mark lengths.

### RTH1

STAINLESS STEEL  
BRAID TEFLON\* HOSE



#### RECOMMENDED FOR:

High pressure hydraulic oil lines. Fluids at extremes of pressure and temperature. RYCO RTH1 Series Hose Lining is chemically pure, inert and contains no leachable additives. RYCO RTH1 is remarkably resistant to high temperature and flame. It has a very high melting point, thermal degradation threshold and auto-ignition temperature. Warning: RTH1 Hose Liner is non-conductive. Do not use with high velocity fluids and gases, as static electricity may be generated and cause premature failure of hose. If in doubt contact RYCO Hydraulics technical department.

#### PERFORMANCE:

Meets or Exceeds the Performance Requirements of: SAE 100R14. RTH112 meets ID and OD requirements of SAE 100R14. Other sizes have ID and OD different to SAE 100R14.

#### TUBE:

TEFLON® (PTFE).

#### REINFORCEMENT:

One braid of high tensile Grade 304 stainless steel wire.

#### TEMPERATURE RANGE:

From -60°C to +260°C (-76°F to +500°F).  
(According to application).  
For water, emulsions etc. see page 58.

WORKING TEMPERATURE		% OF WORKING PRESSURE THAT MAY BE USED SAFELY
°C	°F	Percentage
-60°C to +100°C	(-76°F to +212°F)	100
+101°C to +150°C	(+214°F to +302°F)	93
+151°C to +200°C	(+304°F to +392°F)	85
+201°C to +250°C	(+394°F to +482°F)	77
+251°C to +260°C	(+484°F to +500°F)	70

#### WORKING PRESSURE:

Maximum working pressures are based on 4:1 safety factor (maximum working pressure to minimum burst pressure).

#### THIRD PARTY APPROVALS:

ABS, DNV-GL, LR, MED, USCG, DOT, GOST-R, BV, RINA and KR.

#### COUPLINGS:

##### ONE-PIECE CRIMP

**TT000 Series** (sizes -04 to -16) pages 317 to 320.  
Assembly instructions page 480.

RTH1 - TEFLON* HOSE																	
PART NO	HOSE SIZE	NOMINAL HOSE ID		NOMINAL HOSE OD		MAXIMUM WORKING PRESSURE		MAXIMUM WORKING PRESSURE SAE 100R14		MINIMUM BURST PRESSURE		MINIMUM BEND RADIUS		AVERAGE WEIGHT		COUPLING SERIES	
		mm	inch	mm	inch	bar	psi	bar	psi	bar	psi	mm	inch	kg/m	lb/ft	ONE PIECE	
RTH14	6 -04	6,4	1/4	9,4	0,37	170	2450	105	1500	680	9800	75	3.0	0,12	0.08	TT000	
RTH16	10 -06	9,5	3/8	11,7	0,46	165	2375	105	1500	660	9500	125	5.0	0,14	0.09	TT000	
RTH18	12 -08	12,7	1/2	15,4	0,61	120	1750	56	800	485	7000	140	5.5	0,22	0.15	TT000	
RTH110	16 -10	15,9	5/8	18,4	0,72	105	1500	56	800	420	6000	165	6.5	0,28	0.19	TT000	
RTH112	19 -12	19,1	3/4	22,1	0,87	85	1250	56	800	345	5000	200	8.0	0,33	0.22	TT000	
RTH116	25 -16	25,4	1	28,6	1,13	55	800	56	800	220	3200	300	12.0	0,46	0.31	TT000	

\* DuPont Registered TM  
Refer to the latest RYCO Crimp Charts for crimp diameter and mark lengths.

# PL1

PUSH-ON HOSE  
ONE TEXTILE BRAID HOSE

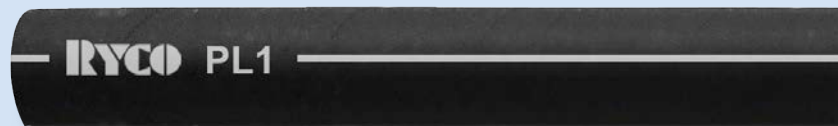

INTRODUCTION

HOSE

COUPLINGS

ADAPTORS

TECHNICAL

**RECOMMENDED FOR:**

Petroleum base hydraulic oils, glycol antifreeze solutions, water, diesel fuels, and air.

**PERFORMANCE:**

Meets or Exceeds the Performance Requirements of: AS 3791 100R6, DIN 20021-1TE, ISO 4079 Type 1, SAE 100R6.

**TUBE:**

Black, oil resistant synthetic rubber.

**REINFORCEMENT:**

One textile braid.

**COVER:**

Black, oil and abrasion resistant synthetic rubber. No skiving required with T4000 Series Crimp Couplings.

**FRAS - FLAME RESISTANCE AND ANTI-STATIC:**

Meets either Flame Resistance Designation "U.S. MSHA" of the US Department of Labor, Mine Safety and Health Administration; or "GL" Germanischer Lloyd. Contact RYCO for further information.

**TEMPERATURE RANGE:**

From -40°C to +95°C (-40°F to +203°F). For water, emulsions etc. see page <?>.

**WORKING PRESSURE:**

Maximum working pressures are based on 4:1 safety factor (maximum working pressure to minimum burst pressure). PL1 Hose, and 800 Series Push-On Fittings, are recommended for use in systems with Static Working Pressures (constant loads without pressure spikes) only. They are not recommended for vibration or pressure surge applications. PL1 Hose should not be used at both maximum working pressure and maximum temperature simultaneously.

**COUPLINGS:**

**NON-SKIVE ONE-PIECE CRIMP**

**T4000 Series** (Sizes -04 to -12) pages 233 to 249. Assembly Instructions pages 478.

**FIELD ATTACHABLE NON-SKIVE**

**8000 Series Push-On** (sizes -04 to -12) pages 325 to 331. PL1 Hose simply pushes on to 8000 Series Couplings. For diesel fuel and other potentially dangerous, or critical applications crimp fittings are required.

PL1 PUSH ON HOSE																		
PART NO	HOSE SIZE	NOMINAL HOSE ID		NOMINAL HOSE OD		MAXIMUM STATIC WORKING PRESSURE		MINIMUM BURST PRESSURE		MINIMUM BEND RADIUS		VACUUM RATING		AVERAGE WEIGHT		ONE PC	PUSH ON	
Hose	DN	Dash	mm	inch	mm	inch	bar	psi	bar	psi	mm	inch	mmHg	inHg	kg/m	lb/ft	NON-SKIVE	
PL14	6	-04	6,6	1/4	12,3	0.48	28	410	112	1640	65	2.5	710	28	0,12	0.08	T4000	8000
PL15	8	-05	8,2	5/16	13,9	0.55	28	410	112	1640	75	3.0	710	28	0,14	0.09	T4000	8000
PL16	10	-06	9,8	3/8	15,5	0.61	28	410	112	1640	75	3.0	635	25	0,17	0.11	T4000	8000
PL18	12	-08	13,0	1/2	19,0	0.75	28	410	112	1640	100	4.0	460	18	0,22	0.15	T4000	8000
PL110	16	-10	16,2	5/8	22,6	0.89	24	350	96	1400	125	5.0	380	15	0,29	0.19	T4000	8000
PL112	19	-12	19,1	3/4	25,8	1.02	21	305	84	1220	150	6.0	380	15	0,34	0.23	T4000	8000

# HOSE

## TEXTILE BRAID

### PL1D

EXTRA ABRASION RESISTANT  
FRAS  
ONE TEXTILE BRAID HOSE  
PUSH ON HOSE



#### RECOMMENDED FOR:

Petroleum base hydraulic oils, glycol antifreeze solutions, water, diesel fuels, and air.

#### PERFORMANCE:

Meets or Exceeds the Performance Requirements of: AS 3791 100R6, DIN 20021-1TE, ISO 4079 Type R6, SAE 100R6.

#### TUBE:

Black, oil resistant synthetic rubber.

#### REINFORCEMENT:

One textile braid.

#### COVER:

**DIEHARD™** Black, oil and extra abrasion resistant synthetic rubber. Flame Resistant, Anti-Static (FRAS) & MSHA compliant. No skiving required with T4000 Series Crimp Couplings.

#### FRAS - FLAME RESISTANCE AND ANTI-STATIC:

**DIEHARD™ FRAS** textile braided hose meets or exceeds the Flame Resistance of U.S.A. MSHA Code of Federal Regulations Title 30 Part 18 Section 18.65 and the Anti-Static requirements of MDG 41, AS1180-13A and ISO 8031 having a resistance of less than 1MΩ per metre.

#### TEMPERATURE RANGE:

From -40°C to +100°C (-40°F to +212°F).  
For water, emulsions etc. see page 58.

#### WORKING PRESSURE:

Maximum working pressures are based on 4:1 safety factor (maximum working pressure to minimum burst pressure). PL1D Hose, and 8000 Series Push-On Fittings, are recommended for use in systems with Static Working Pressures (constant loads without pressure spikes) only. They are not recommended for vibration or pressure surge applications. PL1D Hose should not be used at both maximum working pressure and maximum temperature simultaneously.

#### COUPLINGS:

##### NON-SKIVE ONE-PIECE CRIMP

**T4000 Series** (Sizes -04 to -12) pages 233 to 249. Assembly Instructions pages 478.

##### FIELD ATTACHABLE NON-SKIVE

**8000 Series Push-On** (sizes -04 to -12) pages 325 to 331. PL1D Hose simply pushes on to 8000 Series Couplings. For diesel fuel and other potentially dangerous, or critical applications crimp fittings are required.

PL1D PUSH ON HOSE																		
PART NO	HOSE SIZE	NOMINAL HOSE ID		NOMINAL HOSE OD		MAXIMUM STATIC WORKING PRESSURE		MINIMUM BURST PRESSURE		MINIMUM BEND RADIUS		VACUUM RATING		AVERAGE WEIGHT		ONE PC	PUSH ON	
Hose	DN	Dash	mm	inch	mm	inch	bar	psi	bar	psi	mm	inch	mmHg	inHg	kg/m	lb/ft	NON-SKIVE	
PL14D	6	-04	6,6	1/4	12,7	0.50	30	435	120	1740	65	2.6	710	28	0,12	0.08	T4000	8000
PL15D	8	-05	8,2	5/16	14,3	0.56	30	435	120	1740	75	3.0	710	28	0,15	0.10	T4000	8000
PL16D	10	-06	9,8	3/8	15,9	0.63	30	435	120	1740	75	3.0	635	25	0,17	0.11	T4000	8000
PL18D	12	-08	13,0	1/2	19,8	0.78	30	435	120	1740	90	3.5	460	18	0,23	0.15	T4000	8000
PL110D	16	-10	16,2	5/8	23,0	0.91	26	375	104	1500	125	4.9	380	15	0,29	0.19	T4000	8000
PL112D	19	-12	19,1	3/4	26,4	1.04	22	320	88	1280	150	5.9	380	15	0,36	0.24	T4000	8000



# PL1PV

FIRE RESISTANT UL94 V-0  
ONE TEXTILE BRAID HOSE  
PUSH ON HOSE

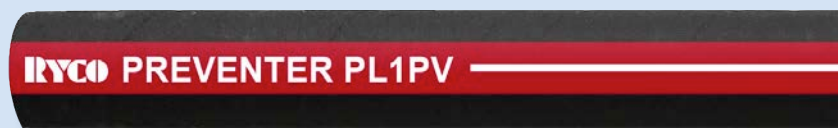

INTRODUCTION

HOSE

COUPLINGS

ADAPTORS

TECHNICAL

### RECOMMENDED FOR:

Petroleum base hydraulic oils, glycol antifreeze solutions, water, diesel fuels, and air.

### PERFORMANCE:

Meets or Exceeds the Performance Requirements of: AS 3791 100R6, ISO 4079 Type 1, SAE 100R6.

### TUBE:

Black, oil resistant synthetic rubber.

### REINFORCEMENT:

One textile braid.

### COVER:

Black, oil and flame resistant synthetic rubber. Highly visible layline branding for easy and permanent identification. No skiving required with T4000 Series Crimp Couplings.

### FLAME RESISTANCE:

Meets flame resistance requirements of UL94 V-0 - Standard for tests of flammability of plastic materials for parts and appliances. Certification No 20170622-E489804.

### TEMPERATURE RANGE:

From -40°C to +100°C (-40°F to +212°F).  
For water, emulsions etc. see page 58.

### WORKING PRESSURE:

Maximum working pressures are based on 4:1 safety factor (maximum working pressure to minimum burst pressure). PL1PV Hose, and 8000 Series Push-On Fittings, are recommended for use in systems with Static Working Pressures (constant loads without pressure spikes) only. They are not recommended for vibration or pressure surge applications. PL1PV Hose should not be used at both maximum working pressure and maximum temperature simultaneously.

### COUPLINGS:

#### NON-SKIVE ONE-PIECE CRIMP

**T4000 Series** (Sizes -04 to -12) pages 233 to 249.  
Assembly Instructions pages 478.

#### FIELD ATTACHABLE NON-SKIVE

**8000 Series Push-On** (sizes -04 to -12) pages 325 to 331.  
PL1PV Hose simply pushes on to 8000 Series Couplings. For diesel fuel and other potentially dangerous, or critical applications crimp fittings are required.

PL1 PV PUSH ON HOSE																	
PART NO	HOSE SIZE	NOMINAL HOSE ID		NOMINAL HOSE OD		MAXIMUM STATIC WORKING PRESSURE		MINIMUM BURST PRESSURE		MINIMUM BEND RADIUS		VACUUM RATING		AVERAGE WEIGHT		COUPLING SERIES	
		mm	inch	mm	inch	bar	psi	bar	psi	mm	inch	mmHg	inHg	kg/m	lb/ft	ONE PC	PUSH ON
<b>PL14PV</b>	6 -04	6,6	1/4	12,7	0.50	30	410	112	1640	65	3.0	710	28	0,12	0.08	T4000	8000
<b>PL15PV</b>	8 -05	8,2	5/16	14,3	0.56	30	410	112	1640	75	3.0	710	28	0,15	0.10	T4000	8000
<b>PL16PV</b>	10 -06	9,8	3/8	15,9	0.63	30	410	112	1640	75	3.0	635	25	0,17	0.11	T4000	8000
<b>PL18PV</b>	12 -08	13,0	1/2	19,8	0.78	30	410	112	1640	100	5.0	460	18	0,23	0.15	T4000	8000
<b>PL110PV</b>	16 -10	16,2	5/8	23,0	0.91	26	350	96	1400	125	6.0	380	15	0,29	0.19	T4000	8000
<b>PL112PV</b>	19 -12	19,1	3/4	26,4	1.04	22	305	84	1220	150	6.9	380	15	0,36	0.24	T4000	8000

# HOSE

## TEXTILE BRAID

# M1

FUEL LINE  
ONE TEXTILE BRAID HOSE



### RECOMMENDED FOR:

Multi-purpose hose for use on fuel lines, PCV and EEC systems, and for fuel return hose connections on diesel fuel injection systems. For use with leaded and unleaded petrol, oil, diesel and other fuels.

### PERFORMANCE:

Meets or Exceeds the Performance Requirements of: SAE 30R7.

### TUBE:

Black, oil resistant synthetic rubber.

### REINFORCEMENT:

One textile braid.

### COVER:

Black, oil resistant synthetic rubber. Resists the effects of high heat and ozone found in engine compartments.

### TEMPERATURE RANGE:

From -40°C to +125°C (-40°F to +257°F).  
For water, emulsions etc. see page 58.

### WORKING PRESSURE:

Maximum working pressures are based on 4:1 safety factor (maximum working pressure to minimum burst pressure).

M1 – FUEL LINE HOSE																
PART NO	HOSE SIZE	NOMINAL HOSE ID		NOMINAL HOSE OD		MAXIMUM WORKING PRESSURE		MINIMUM BURST PRESSURE		MINIMUM BEND RADIUS		AVERAGE WEIGHT		VACUUM RATING AT 20°C (68°F)		
Hose	DN	Dash	mm	inch	mm	inch	bar	psi	bar	psi	mm	inch	kg/m	lb/ft	mmHg	inHg
M14	6	-04	6,4	1/4	12,7	0.50	3,5	50	14	200	75	3.0	0,14	0.09	610	24
M15	8	-05	7,9	5/16	14,3	0.56	3,5	50	14	200	75	3.0	0,17	0.11	610	24
M16	10	-06	9,5	3/8	15,9	0.63	3,5	50	14	200	100	4.0	0,18	0.12	610	24

# MP1

MULTI PURPOSE  
ONE TEXTILE BRAID HOSE

INTRODUCTION

HOSE

COUPLINGS

ADAPTORS

TECHNICAL

### RECOMMENDED FOR:

Air, water, petroleum oils, kerosene and fuel oils.

### PERFORMANCE:

Meets or Exceeds the Performance Requirements of:  
RMA (USA) Class A High Oil Resistance (tube),  
RMA (USA) Class B Medium Oil Resistance (cover),

### TUBE:

Black, oil resistant synthetic rubber. RMA (USA) Class A High Oil Resistance.

### REINFORCEMENT:

One textile braid.

### COVER:

Red, oil resistant and abrasion resistant synthetic rubber (Modified Nitrile). RMA (USA) Class B Medium Oil Resistance. No skiving required with T4000 Series Crimp Couplings.

### FEATURES:

Tube non-conductive at 1000 volts DC. Meets electrical resistance of one megohm per inch when subjected to 1000 volts DC. Incorrect storage and use may adversely affect electrical properties.

### TEMPERATURE RANGE:

Air, water, petroleum & lubricating oils: -40°C to +93°C (-40°F to +200°F). Petrol, kerosene, fuel oils: -40°C to +49°C (-40°F to +120°F). For continuous service at upper temperature limit, reduce maximum working pressure by 30%. For water, emulsions etc. see page 58.

### WORKING PRESSURE:

Maximum working pressures are based on 4:1 safety factor (maximum working pressure to minimum burst pressure), and are for the performance of the hose with RYCO T4000 Series BITELOK One-Piece couplings only. Maximum working pressure for a hose assembly with other couplings depends on the type of coupling and the type of clamp used. MP1 Hose should not be used at maximum working pressure and maximum working temperature simultaneously.

### COUPLINGS:

#### NON-SKIVE ONE-PIECE CRIMP

**T4000 Series** (Sizes -04 to -20) pages 233 to 249. Assembly Instructions pages 478.

Standard industrial hose barbed tails with hose clamps may also be suitable depending on working pressure required.

**Not suitable for use with RYCO 8000 Series Push-On couplings.**

MP1 - MULTI PURPOSE HOSE															
PART NO	HOSE SIZE	NOMINAL HOSE ID		NOMINAL HOSE OD		MAXIMUM WORKING PRESSURE		MINIMUM BURST PRESSURE		MINIMUM BEND RADIUS		AVERAGE WEIGHT		COUPLING SERIES ONE PIECE	
Hose	DN	Dash	mm	inch	mm	inch	bar	psi	bar	psi	mm	inch	kg/m	lb/ft	NON-SKIVE
MP14	6	-04	6,4	1/4	13,5	0.53	13,8	200	55,2	800	50	2.0	0,16	0.11	T4000
MP16	10	-06	9,5	3/8	17,5	0.69	13,8	200	55,2	800	70	3.0	0,24	0.16	T4000
MP18	12	-08	12,7	1/2	21,4	0.84	13,8	200	55,2	800	85	4.0	0,33	0.22	T4000
MP110	16	-10	15,9	5/8	25,4	1.00	13,8	200	55,2	800	105	5.0	0,43	0.29	T4000
MP112	19	-12	19,1	3/4	28,6	1.13	13,8	200	55,2	800	120	5.0	0,48	0.32	T4000
MP116	25	-16	25,4	1	37,3	1.47	13,8	200	55,2	800	155	8.0	0,82	0.55	T4000
MP120	31	-20	31,8	1.1/4	43,9	1.73	13,8	200	55,2	800	230	10.0	1,00	0.68	T4000

Refer to the latest RYCO Crimp Charts for crimp diameter and mark lengths.

# HOSE

## TEXTILE BRAID

# M2

TEXTILE  
TWO TEXTILE BRAID HOSE

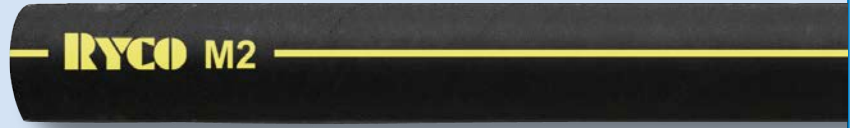

**RECOMMENDED FOR:**

Medium pressure hydraulic oil lines, antifreeze solutions, water.

**PERFORMANCE:**

Meets or Exceeds the Performance Requirements of: AS 3791 100R3, DIN 20021-2TE, ISO 4079 Type R3, SAE 100R3.

**TUBE:**

Black, oil resistant synthetic rubber.

**REINFORCEMENT:**

Two textile braids.

**COVER:**

Black, oil resistant and abrasion resistant synthetic rubber. No skiving required with T4000 Series Crimp Couplings and M000 Series Field Attachable Couplings.

**MSHA - FLAME RESISTANCE:**

Meets Flame Resistant Designation "U.S. MSHA" of the US Department of Labor, Mine Safety and Health Administration. Complies with Flame Resistant requirements of Australian Standard AS 2660 and Method of Test AS 1180.10B.

**TEMPERATURE RANGE:**

From -40°C to +100°C (-40°F to +212°F). For water, emulsions etc. see page 58.

**WORKING PRESSURE:**

Maximum working pressures are based on 4:1 safety factor (maximum working pressure to minimum burst pressure).

**THIRD PARTY APPROVALS:**

ABS, DNV-GL, LR, MED, USCG, DOT, GOST-R, BV, RINA and KR.

**COUPLINGS:**

**NON-SKIVE ONE-PIECE CRIMP**

**T4000 Series** (Sizes -04 to -12) pages 233 to 249. Assembly Instructions pages 478.

**FIELD ATTACHABLE NON-SKIVE**

**6000 SERIES** insert (sizes -04 to -12) pages 250 to 271.

**M000 Series** ferrule (sizes -04 to -12) page 353.

Assembly Instructions page 476.

M2 - TEXTILE BRAID																
PART NO	HOSE SIZE	NOMINAL HOSE ID		NOMINAL HOSE OD		MAXIMUM WORKING PRESSURE		MINIMUM BURST PRESSURE		MINIMUM BEND RADIUS		AVERAGE WEIGHT		ONE PC	FIELD ATT	
Hose	DN	Dash	mm	inch	mm	inch	bar	psi	bar	psi	mm	inch	kg/m	lb/ft	NON-SKIVE	
M24	6	-04	6,4	1/4	14,3	0.56	88	1250	350	5000	75	3.0	0,16	0.11	T4000	6000 (M000)
M25	8	-05	7.9	5/16											T4000	6000 (M000)
M26	10	-06	9,5	3/8	19,0	0.75	78	1125	312	4500	100	4.0	0,28	0.19	T4000	6000 (M000)
M28	12	-08	12,7	1/2	23,8	0.94	70	1000	280	4000	125	5.0	0,41	0.28	T4000	6000 (M000)
M212	19	-12	19,1	3/4	31,7	1.25	52	750	210	3000	150	9.5	0,65	0.44	T4000	6000 (M000)

Refer to the latest RYCO Crimp Charts for crimp diameter and mark lengths.



# M2G

TWO TEXTILE BRAID HOSE  
LPG (CLASS C)

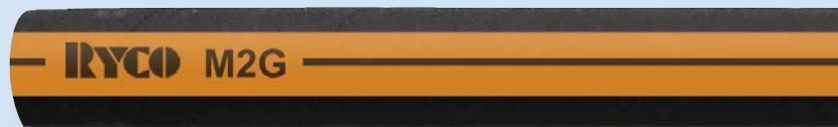

INTRODUCTION

HOSE

COUPLINGS

ADAPTORS

TECHNICAL

## IMPORTANT INFORMATION

RYCO **M2G Series** LPG Hose has Australian Gas Association approval (AGA approval No. 4247) only when used with RYCO **T4000 Series** One-Piece Non-Skive Crimp Couplings, or RYCO **M000 Series** Field Attachables.

### AVAILABLE ONLY AS FACTORY FITTED HOSE ASSEMBLIES.

**WARNING:** Do not use Field Attachable Couplings for domestic applications. (This is a requirement of Australian Standard AS/NZS 1869).

For any queries, please contact RYCO Technical Department.

### RECOMMENDED FOR:

Liquefied Petroleum Gas and Natural Gas.

### PERFORMANCE:

Meets or Exceeds the Performance Requirements of: AS/NZS 1869 Class C (2,6 MPa working pressure, +65°C/+149°F max. temperature).

### TUBE:

Black, oil resistant synthetic rubber.

### REINFORCEMENT:

Two textile braids.

### COVER:

Black, abrasion resistant synthetic rubber. Pin-pricked (perforated). No skiving required with T4000 Series Crimp Couplings and M000 Series Field Attachable Couplings.

### TEMPERATURE RANGE:

From -20°C to +65°C (-4°F to +149°F).

### THIRD PARTY APPROVALS:

AUSTRALIAN GAS ASSOCIATION Approval No. 4247.

### COUPLINGS:

#### NON-SKIVE ONE-PIECE CRIMP

**T4000 Series** (Sizes -04 to -12) pages 233 to 249. Assembly Instructions pages 478.

#### FIELD ATTACHABLE NON-SKIVE

**6000 SERIES** insert (sizes -04 to -12) pages 250 to 271.

**M000 Series** ferrule (sizes -04 to -12) page 353.

Assembly Instructions page 476.

M2G - LPG HOSE																
PART NO	HOSE SIZE	NOMINAL HOSE ID		NOMINAL HOSE OD		MAXIMUM WORKING PRESSURE		MINIMUM BURST PRESSURE		MINIMUM BEND RADIUS		AVERAGE WEIGHT		COUPLING SERIES		
		mm	inch	mm	inch	bar	psi	bar	psi	mm	inch	kg/m	lb/ft	ONE PC	FIELD ATT	
<b>M24G</b>	6	-04	6,4	1/4	14,3	0.56	26	375	104	1500	75	3.0	0,16	0.11	T4000	6000 (M000)
<b>M26G</b>	10	-06	9,5	3/8	19,0	0.75	26	375	104	1500	100	4.0	0,28	0.19	T4000	6000 (M000)
<b>M28G</b>	12	-08	12,7	1/2	23,8	0.94	26	375	104	1500	125	5.0	0,41	0.28	T4000	6000 (M000)
<b>M212G</b>	19	-12	19,1	3/4	31,7	1.25	26	375	104	1500	240	9.5	0,65	0.44	T4000	6000 (M000)

Refer to the latest RYCO Crimp Charts for crimp diameter and mark lengths.



# SPIDERLINE

KINK FREE FLEXIBILITY



IRYCO SPIDERLINE TP76 3/8" -06 DN10 MAX WP 160 E

TP7 & TP7T (SAE 100R7)

IRYCO SPIDERLINE TP3000 3/8" -06 DN10 MAX WP 280 I

TP8 & TP8T (SAE 100R8)

COMPACT OUTSIDE  
DIAMETER

REDUCE WEIGHT



# ISOLATOR

THERMOPLASTIC HOSE



RYCO ISOLATOR TP76N 3/8" -06 DN10 MAX WP 16

TP7N & TP7TN (Sae 100R7)

RYCO ISOLATOR TP86N 3/8" -06 DN10 MAX WP 20

TP8N & TP8TN (Sae 100R8)

ELECTRICAL  
NON-CONDUCTIVITY

COMPACT OUTSIDE  
DIAMETER

REDUCE WEIGHT

# HOSE

## THERMOPLASTIC

### TP7

#### SPIDERLINE R7 HOSE

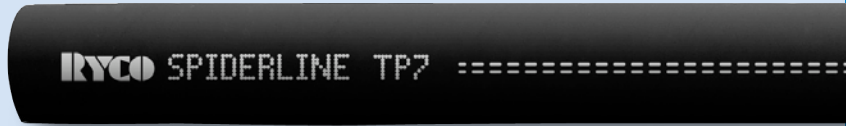

#### RECOMMENDED FOR:

High pressure hydraulic oil lines; pilot lines; greasing and lubrication lines; and some pneumatic and water lines. Suitable for use with mineral, vegetable and most ester based hydraulic fluids. Suitable for use with some gases, fluids and chemicals. Cover is perforated (pin-pricked) for use with air and gases.

RYCO SPIDERLINE hose is lighter weight, has a more compact outside diameter and is less than half the minimum bend radius of wire braided rubber hose. Smooth inner tube for high flow rate; and smooth, easily cleaned cover.

The synthetic and aramid fibre reinforcement gives SPIDERLINE hose excellent corrosion and fatigue resistance plus low elongation at maximum dynamic working pressure.

#### PERFORMANCE:

Meets or Exceeds the Performance Requirements of: AS 3791 100R7, EN 855 TYPE R7, ISO 3949, SAE 100R7.

#### TUBE:

White, oil resistant seamless thermoplastic (Polyester).

#### REINFORCEMENT:

One or two braids of synthetic fibre.

#### COVER:

Black, oil and abrasion resistant thermoplastic (Polyurethane). Cover is perforated (pin-pricked).

#### TEMPERATURE RANGE:

From -40°C to +100°C (-40°F to +212°F).

Air & Water +70 °C (+158 °F).

For water, emulsions etc. see page 58.

#### WORKING PRESSURE:

Maximum working pressures are based on 4:1 safety factor (maximum working pressure to minimum burst pressure).

#### COUPLINGS:

##### NON-SKIVE ONE-PIECE CRIMP

**TP000 Series** (sizes -03 to -16) pages 304 to 316.

Assembly Instructions pages 478.

TP7 - SPIDERLINE HOSE															
PART NO	HOSE SIZE	NOMINAL HOSE ID		NOMINAL HOSE OD		MAXIMUM WORKING PRESSURE		MINIMUM BURST PRESSURE		MINIMUM BEND RADIUS		AVERAGE WEIGHT		COUPLING SERIES ONE PIECE	
Hose	DN	Dash	mm	inch	mm	inch	bar	psi	bar	psi	mm	inch	kg/m	lb/ft	NON-SKIVE
TP73	5	-03	5,0	3/16	9,6	0.38	210	3000	840	12000	25	1.0	0,06	0.04	TP000
TP74	6	-04	6,5	1/4	12,2	0.48	210	3000	840	12000	35	1.4	0,10	0.07	TP000
TP75	8	-05	8,1	5/16	14,3	0.56	190	2700	760	10800	45	1.8	0,13	0.09	TP000
TP76	10	-06	9,7	3/8	16,0	0.63	160	2300	640	9200	55	2.2	0,15	0.10	TP000
TP78	12	-08	13,0	1/2	20,3	0.80	140	2000	560	8000	75	3.0	0,22	0.15	TP000
TP712	19	-12	19,5	3/4	27,1	1.07	90	1300	360	5200	140	5.5	0,34	0.23	TP000
TP716	25	-16	25,9	1	34,0	1.34	70	1000	280	4000	190	7.5	0,46	0.31	TP000

Refer to the latest RYCO Crimp Charts for crimp diameter and mark lengths.



# TP7N

ISOLATOR  
R7 NON CONDUCTIVE HOSE



## RECOMMENDED FOR:

Hydraulic oil lines where electrical non-conductivity is required (for use in applications where there is potential for contact with high voltage sources). Suitable for use with mineral, vegetable and most ester based hydraulic fluids. Heat and hydrolysis stabilised for use with water based hydraulic fluids up to +70°C (+158°F). Smooth inner tube for high flow rate; and smooth, easily cleaned cover. The high strength, non-metallic reinforcement gives these hoses excellent corrosion and fatigue resistance, and low elongation of ±2% at maximum dynamic working pressure.

## PERFORMANCE:

Meets or Exceeds the Performance Requirements of: AS 3791 100R7, EN 855 TYPE R7, ISO 3949, SAE 100R7.

## TUBE:

White, oil resistant seamless thermoplastic (Polyester).

## REINFORCEMENT:

One or two braids of synthetic fibre.

## COVER:

Orange, oil and abrasion resistant thermoplastic (Polyurethane). Cover is non-perforated.

## FEATURES:

Meets non-conductivity requirements of SAE 100R7, AS 3791 100R7, EN 855 Type 7 (maximum leakage does not exceed 50 µA when subjected to 75 kV/305 mm or 250 kV/m for 5 minutes). Incorrect storage and use, particularly that leading to oil or moisture entering the reinforcement, may adversely affect electrical properties.

## TEMPERATURE RANGE:

From -40°C to +100°C (-40°F to +212°F).  
Air & Water +70 °C (+158 °F).  
For water, emulsions etc. see page 58.

## WORKING PRESSURE:

Maximum working pressures are based on 4:1 safety factor (maximum working pressure to minimum burst pressure).

## COUPLINGS:

### NON-SKIVE ONE-PIECE CRIMP

**TP000 Series** (sizes -04 to -16) pages 304 to 316.  
Assembly Instructions pages 478.

TP7N - ISOLATOR NON-CONDUCTIVE HOSE																
PART NO	HOSE SIZE		NOMINAL HOSE ID		NOMINAL HOSE OD		MAXIMUM WORKING PRESSURE		MINIMUM BURST PRESSURE		MINIMUM BEND RADIUS		AVERAGE WEIGHT		ONE PIECE	
Hose	DN	Dash	mm	inch	mm	inch	bar	psi	bar	psi	mm	inch	kg/m	lb/ft	NON-SKIVE	
TP74N	6	-04	6,5	1/4	12,2	0.48	210	3000	840	12000	35	1.4	0,10	0.07	TP000	
TP76N	10	-06	9,7	3/8	16,0	0.63	160	2300	640	9200	55	2.2	0,15	0.10	TP000	
TP78N	12	-08	13,0	1/2	20,3	0.80	140	2000	560	8000	75	3.0	0,22	0.15	TP000	
TP712N	19	-12	19,5	3/4	27,1	1.07	90	1300	360	5200	140	5.5	0,34	0.23	TP000	
TP716N	25	-16	25,9	1	34,0	1.34	70	1000	280	4000	190	7.5	0,46	0.31	TP000	

Refer to the latest RYCO Crimp Charts for crimp diameter and mark lengths.

# HOSE

## THERMOPLASTIC

### TP7T

SPIDERLINE  
R7 TWIN HOSE



#### RECOMMENDED FOR:

RYCO TP7T SPIDERLINE TWIN Hose consists of two TP7 Series Hoses of the same size, permanently joined together in a flat compact form that can be easily reeled onto payout and return reels on forklifts and cranes. It is also used on dispensing equipment and other applications requiring two hoses.

High pressure hydraulic oil lines; pilot lines; greasing and lubrication lines; and some pneumatic and water lines. Suitable for use with mineral, vegetable and most ester based hydraulic fluids. Suitable for use with some gases, fluids and chemicals. Cover is perforated (pin-pricked) for use with air and gases.

RYCO SPIDERLINE hose is lighter weight, has a more compact outside diameter and is less than half the minimum bend radius of wire braided rubber hose. Smooth inner tube for high flow rate; and smooth, easily cleaned cover.

The synthetic and aramid fibre reinforcement gives SPIDERLINE hose excellent corrosion and fatigue resistance plus low elongation at maximum dynamic working pressure.

#### PERFORMANCE:

Meets or Exceeds the Performance Requirements of: AS 3791 100R7, EN 855 TYPE R7, ISO 3949, SAE 100R7.

#### TUBE:

White, oil resistant seamless thermoplastic (Polyester).

#### REINFORCEMENT:

One or two braids of synthetic fibre.

#### COVER:

Black, oil and abrasion resistant thermoplastic (Polyurethane). Cover is perforated (pin-pricked).

#### TEMPERATURE RANGE:

From -40°C to +100°C (-40°F to +212°F).

Air & Water +70 °C (+158 °F).

For water, emulsions etc. see page 58.

#### WORKING PRESSURE:

Maximum working pressures are based on 4:1 safety factor (maximum working pressure to minimum burst pressure).

#### COUPLINGS:

##### NON-SKIVE ONE-PIECE CRIMP

**TP000 Series** (sizes -04 to -16) pages 304 to 316. Assembly Instructions pages 478.

TP7T – SPIDERLINE TWIN HOSE															
PART NO	HOSE SIZE	NOMINAL HOSE ID		NOMINAL HOSE OD		MAXIMUM WORKING PRESSURE		MINIMUM BURST PRESSURE		MINIMUM BEND RADIUS		AVERAGE WEIGHT		ONE PIECE	
Hose	DN	Dash	mm	inch	mm	inch	bar	psi	bar	psi	mm	inch	kg/m	lb/ft	NON-SKIVE
TP74T	6	-04	6,5	1/4	12,2	0.48	210	3000	840	12000	35	1.4	0,20	0.13	TP000
TP75T	8	-05	8,1	5/16	14,3	0.56	190	2700	760	10800	45	1.8	0,26	0.18	TP000
TP76T	10	-06	9,7	3/8	16,0	0.63	160	2300	640	9200	55	2.2	0,30	0.20	TP000
TP78T	12	-08	13,0	1/2	20,3	0.80	140	2000	560	8000	75	3.0	0,44	0.30	TP000

Refer to the latest RYCO Crimp Charts for crimp diameter and mark lengths.

# TP7TN

ISOLATOR  
R7 NON CONDUCTIVE  
TWIN HOSE



INTRODUCTION

HOSE

COUPLINGS

ADAPTORS

TECHNICAL

**RECOMMENDED FOR:**

RYCO TP7TN ISOLATOR TWIN Hose consists of two TP7N Series Hoses of the same size, permanently joined together in a flat compact form that can be easily reeled onto payout and return reels on forklifts and cranes. It is also used for hydraulic powered hand tools, such as loppers and chain saws, and other applications requiring two hoses. TP7TN is used where electrical non-conductivity is required (for use in applications where there is potential for contact with high voltage sources). Suitable for use with mineral, vegetable and most ester based hydraulic fluids. Heat and hydrolysis stabilised for use with water based hydraulic fluids up to +70°C (+158°F). Suitable for use with some gases, fluids and chemicals (contact RYCO Hydraulics Technical Department). Smooth inner tube for high flow rate; and smooth, easily cleaned cover. The polyester reinforcement gives TP7TN Hose excellent corrosion and fatigue resistance, and low elongation of ±2% at maximum dynamic working pressure.

**PERFORMANCE:**

Meets or Exceeds the Performance Requirements of: AS 3791 100R7, EN 855 TYPE R7, ISO 3949, SAE 100R7.

**TUBE:**

White, oil resistant seamless thermoplastic (Polyester).

**REINFORCEMENT:**

One or two braids of synthetic fibre.

**COVER:**

Orange, oil and abrasion resistant thermoplastic (Polyurethane). Cover is non-perforated.

**FEATURES:**

Meets non-conductivity requirements of SAE 100R7, AS 3791 100R7, EN 855 Type 7 (maximum leakage does not exceed 50 µA when subjected to 75 kV/305 mm or 250 kV/m for 5 minutes). Incorrect storage and use, particularly that leading to oil or moisture entering the reinforcement, may adversely affect electrical properties.

**TEMPERATURE RANGE:**

From -40°C to +100°C (-40°F to +212°F).  
Air & Water +70 °C (+158 °F).  
For water, emulsions etc. see page 58.

**WORKING PRESSURE:**

Maximum working pressures are based on 4:1 safety factor (maximum working pressure to minimum burst pressure).

**COUPLINGS:**

**NON-SKIVE ONE-PIECE CRIMP**

**TP000 Series** (sizes -04 to -16) pages 304 to 316.  
Assembly Instructions pages 478.

TP7TN – ISOLATOR NON-CONDUCTIVE TWIN HOSE															
PART NO	HOSE SIZE	NOMINAL HOSE ID		NOMINAL HOSE OD		MAXIMUM WORKING PRESSURE		MINIMUM BURST PRESSURE		MINIMUM BEND RADIUS		AVERAGE WEIGHT		ONE PIECE	
Hose	DN	Dash	mm	inch	mm	inch	bar	psi	bar	psi	mm	inch	kg/m	lb/ft	NON-SKIVE
TP74TN	6	-04	6,5	1/4	12,2	0.48	210	3000	840	12000	35	1.4	0,20	0.13	TP000
TP76TN	10	-06	9,7	3/8	16,0	0.63	160	2300	640	9200	55	2.2	0,30	0.20	TP000
TP78TN	12	-08	13,0	1/2	20,3	0.80	140	2000	560	8000	75	3.0	0,44	0.30	TP000

Refer to the latest RYCO Crimp Charts for crimp diameter and mark lengths.

# HOSE

## THERMOPLASTIC

### TP8

SPIDERLINE  
R8 HOSE



#### RECOMMENDED FOR:

High pressure hydraulic oil lines; pilot lines; greasing and lubrication lines; and some pneumatic and water lines. Suitable for use with mineral, vegetable and most ester based hydraulic fluids. Suitable for use with some gases, fluids and chemicals. Cover is perforated (pin-pricked) for use with air and gases.

RYCO SPIDERLINE hose is lighter weight, has a more compact outside diameter and is less than half the minimum bend radius of wire braided rubber hose. Smooth inner tube for high flow rate; and smooth, easily cleaned cover.

The synthetic and aramid fibre reinforcement gives SPIDERLINE hose excellent corrosion and fatigue resistance plus low elongation at maximum dynamic working pressure.

#### PERFORMANCE:

Meets or Exceeds the Performance Requirements of: AS 3791 100R8, EN 855 TYPE R8, ISO 3949, SAE 100R8.

#### TUBE:

White, oil resistant seamless thermoplastic (Polyester).

#### REINFORCEMENT:

One or two braids of aramid fibre.

#### COVER:

Black, oil and abrasion resistant thermoplastic (Polyurethane). Cover is perforated (pin-pricked).

#### TEMPERATURE RANGE:

From -40°C to +100°C (-40°F to +212°F).  
For water, emulsions etc. see page 58.

#### WORKING PRESSURE:

Maximum working pressures are based on 4:1 safety factor (maximum working pressure to minimum burst pressure).

#### COUPLINGS:

##### NON-SKIVE ONE-PIECE CRIMP

**TP000 Series** (sizes -04 to -16) pages 304 to 316.  
Assembly Instructions pages 478.

TP8 – SPIDERLINE HOSE														COUPLING SERIES	
PART NO	HOSE SIZE	NOMINAL HOSE ID		NOMINAL HOSE OD		MAXIMUM WORKING PRESSURE		MINIMUM BURST PRESSURE		MINIMUM BEND RADIUS		AVERAGE WEIGHT		ONE PIECE	
Hose	DN	Dash	mm	inch	mm	inch	bar	psi	bar	psi	mm	inch	kg/m	lb/ft	NON-SKIVE
TP84	6	-04	6,5	1/4	11,5	0.45	350	5000	1400	20000	50	2.0	0,09	0.06	TP000
TP86	10	-06	9,7	3/8	15,5	0.61	280	4000	1120	16000	60	2.4	0,14	0.09	TP000
TP88	12	-08	13,0	1/2	19,9	0.78	245	3500	980	14000	80	3.1	0,20	0.13	TP000

Refer to the latest RYCO Crimp Charts for crimp diameter and mark lengths.





# TP8N

ISOLATOR  
R8 NON CONDUCTIVE HOSE

### RECOMMENDED FOR:

Hydraulic oil lines where electrical non-conductivity is required (for use in applications where there is potential for contact with high voltage sources). Suitable for use with mineral, vegetable and most ester based hydraulic fluids. Heat and hydrolysis stabilised for use with water based hydraulic fluids up to +70°C (+158°F). Smooth inner tube for high flow rate; and smooth, easily cleaned cover. The high strength, non-metallic reinforcement gives these hoses excellent corrosion and fatigue resistance, and low elongation of ±2% at maximum dynamic working pressure.

### PERFORMANCE:

Meets or Exceeds the Performance Requirements of: AS 3791 100R8, EN 855 TYPE R8, ISO 3949, SAE 100R8.

### TUBE:

White, oil resistant seamless thermoplastic (Polyester).

### REINFORCEMENT:

One or two braids of aramid fibre.

### COVER:

Orange, oil and abrasion resistant thermoplastic (Polyurethane). Cover is non-perforated.

### FEATURES:

Meets non-conductivity requirements of SAE 100R7, AS 3791 100R7, EN 855 Type 7 (maximum leakage does not exceed 50 µA when subjected to 75 kV/305 mm or 250 kV/m for 5 minutes). Incorrect storage and use, particularly that leading to oil or moisture entering the reinforcement, may adversely affect electrical properties.

### TEMPERATURE RANGE:

From -40°C to +100°C (-40°F to +212°F).  
Air & Water +70 °C (+158 °F).  
For water, emulsions etc. see page 58.

### WORKING PRESSURE:

Maximum working pressures are based on 4:1 safety factor (maximum working pressure to minimum burst pressure).

### COUPLINGS:

#### NON-SKIVE ONE-PIECE CRIMP

**TP000 Series** (sizes -04 to -16) pages 304 to 316. Assembly Instructions pages 478.

TP8N - ISOLATOR NON-CONDUCTIVE HOSE															
PART NO	HOSE SIZE	NOMINAL HOSE ID		NOMINAL HOSE OD		MAXIMUM WORKING PRESSURE		MINIMUM BURST PRESSURE		MINIMUM BEND RADIUS		AVERAGE WEIGHT		ONE PIECE	
Hose	DN	Dash	mm	inch	mm	inch	bar	psi	bar	psi	mm	inch	kg/m	lb/ft	NON-SKIVE
TP84N	6	-04	6,5	1/4	11,5	0.45	350	5000	1400	20000	50	2.0	0,09	0.06	TP000
TP86N	10	-06	9,7	3/8	15,5	0.61	280	4000	1120	16000	60	2.4	0,14	0.09	TP000
TP88N	12	-08	13,0	1/2	19,9	0.78	245	3500	980	14000	80	3.1	0,20	0.13	TP000

Refer to the latest RYCO Crimp Charts for crimp diameter and mark lengths.

# HOSE

## THERMOPLASTIC

### TP8T

SPIDERLINE  
R8 TWIN HOSE



#### RECOMMENDED FOR:

RYCO TP8T SPIDERLINE TWIN Hose consists of two TP8 Series Hoses of the same size, permanently joined together in a flat compact form that can be easily reeled onto payout and return reels on forklifts and cranes. It is also used on dispensing equipment and other applications requiring two hoses.

High pressure hydraulic oil lines; pilot lines; greasing and lubrication lines; and some pneumatic and water lines. Suitable for use with mineral, vegetable and most ester based hydraulic fluids. Suitable for use with some gases, fluids and chemicals. Cover is perforated (pin-pricked) for use with air and gases.

RYCO SPIDERLINE hose is lighter weight, has a more compact outside diameter and is less than half the minimum bend radius of wire braided rubber hose. Smooth inner tube for high flow rate; and smooth, easily cleaned cover.

The synthetic and aramid fibre reinforcement gives SPIDERLINE hose excellent corrosion and fatigue resistance plus low elongation at maximum dynamic working pressure.

#### PERFORMANCE:

Meets or Exceeds the Performance Requirements of: AS 3791 100R8, EN 855 TYPE R8, ISO 3949, SAE 100R8.

#### TUBE:

White, oil resistant seamless thermoplastic (Polyester).

#### REINFORCEMENT:

One or two braids of aramid fibre.

#### COVER:

Black, oil and abrasion resistant thermoplastic (Polyurethane). Cover is perforated (pin-pricked).

#### TEMPERATURE RANGE:

From -40°C to +100°C (-40°F to +212°F).

Air & Water +70 °C (+158 °F).

For water, emulsions etc. see page 58.

#### WORKING PRESSURE:

Maximum working pressures are based on 4:1 safety factor (maximum working pressure to minimum burst pressure).

#### COUPLINGS:

##### NON-SKIVE ONE-PIECE CRIMP

**TP000 Series** (sizes -04 to -16) pages 304 to 316.

Assembly Instructions pages 478.

TP8T – SPIDERLINE TWIN HOSE															
PART NO	HOSE SIZE	NOMINAL HOSE ID		NOMINAL HOSE OD		MAXIMUM WORKING PRESSURE		MINIMUM BURST PRESSURE		MINIMUM BEND RADIUS		AVERAGE WEIGHT		ONE PIECE	
Hose	DN	Dash	mm	inch	mm	inch	bar	psi	bar	psi	mm	inch	kg/m	lb/ft	NON-SKIVE
TP84T	6	-04	6,5	1/4	11,5	0.45	350	5000	1400	20000	50	2.0	0,17	0.11	TP000
TP86T	10	-06	9,7	3/8	15,5	0.61	280	4000	1120	16000	60	2.4	0,27	0.18	TP000
TP88T	12	-08	13,0	1/2	19,9	0.78	245	3500	980	14000	80	3.1	0,40	0.27	TP000

Refer to the latest RYCO Crimp Charts for crimp diameter and mark lengths.

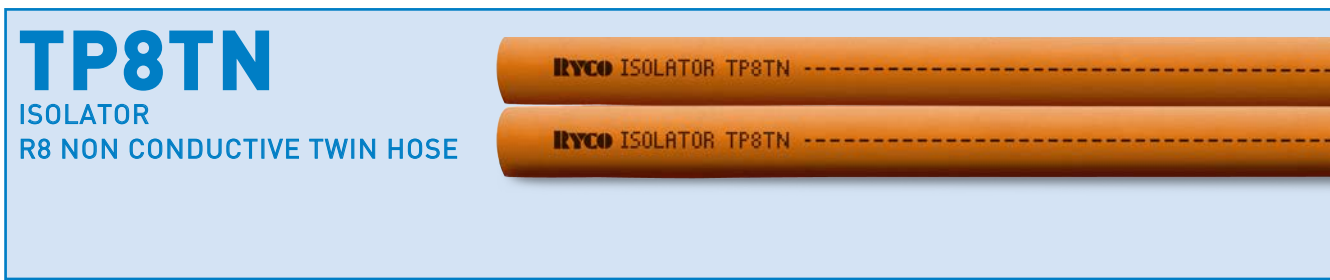

# TP8TN

ISOLATOR  
R8 NON CONDUCTIVE TWIN HOSE

**RECOMMENDED FOR:**

RYCO TP8TN ISOLATOR TWIN Hose consists of two TP8N Series Hoses of the same size, permanently joined together in a flat compact form that can be easily reeled onto payout and return reels on forklifts and cranes. It is also used for hydraulic powered hand tools, such as loppers and chain saws, and other applications requiring two hoses. TP8TN is used where electrical non-conductivity is required (for use in applications where there is potential for contact with high voltage sources). Suitable for use with mineral, vegetable and most ester based hydraulic fluids. Heat and hydrolysis stabilised for use with water based hydraulic fluids up to +70°C (+158°F). Suitable for use with some gases, fluids and chemicals (contact RYCO Hydraulics Technical Department). Smooth inner tube for high flow rate; and smooth, easily cleaned cover. The aramid reinforcement gives TP8TN Hose excellent corrosion and fatigue resistance, and low elongation of ±2% at maximum dynamic working pressure.

**PERFORMANCE:**

Meets or Exceeds the Performance Requirements of: AS 3791 100R8, EN 855 Type R8, ISO 3949, SAE 100R8.

**TUBE:**

White, oil resistant seamless thermoplastic (Polyester).

**REINFORCEMENT:**

One or two braids of aramid fibre.

**COVER:**

Orange, oil and abrasion resistant thermoplastic (Polyurethane). Cover is non-perforated.

**FEATURES:**

Meets non-conductivity requirements of SAE 100R7, AS 3791 100R7, EN 855 Type 7 (maximum leakage does not exceed 50 µA when subjected to 75 kV/305 mm or 250 kV/m for 5 minutes). Incorrect storage and use, particularly that leading to oil or moisture entering the reinforcement, may adversely affect electrical properties.

**TEMPERATURE RANGE:**

From -40°C to +100°C (-40°F to +212°F).  
Air & Water +70 °C (+158 °F).  
For water, emulsions etc. see page 58.

**WORKING PRESSURE:**

Maximum working pressures are based on 4:1 safety factor (maximum working pressure to minimum burst pressure).

**COUPLINGS:**

**NON-SKIVE ONE-PIECE CRIMP**

**TP000 Series** (sizes -04 to -16) pages 304 to 316.  
Assembly Instructions pages 478.

TP8TN - ISOLATOR NON-CONDUCTIVE TWIN HOSE															
PART NO	HOSE SIZE	NOMINAL HOSE ID		NOMINAL HOSE OD		MAXIMUM WORKING PRESSURE		MINIMUM BURST PRESSURE		MINIMUM BEND RADIUS		AVERAGE WEIGHT		ONE PIECE	
Hose	DN	Dash	mm	inch	mm	inch	bar	psi	bar	psi	mm	inch	kg/m	lb/ft	NON-SKIVE
TP84TN	6	-04	6,5	1/4	11,5	0.45	350	5000	1400	20000	50	2.0	0,17	0.11	TP000
TP86TN	10	-06	9,7	3/8	15,5	0.61	280	4000	1120	16000	60	2.4	0,27	0.18	TP000
TP88TN	12	-08	13,0	1/2	19,9	0.78	245	3500	980	14000	80	3.1	0,40	0.27	TP000

Refer to the latest RYCO Crimp Charts for crimp diameter and mark lengths.

# HOSE

## THERMOPLASTIC

### TP3000

LOW TEMPERATURE R18  
ISOBARIC HOSE  
210 BAR / 3000 PSI

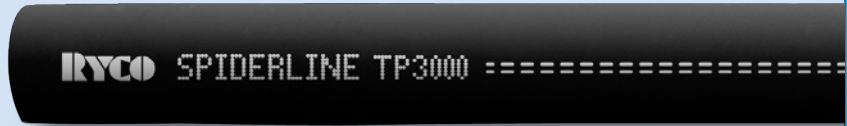

#### RECOMMENDED FOR:

Medium pressure hose suitable for petroleum or synthetic based hydraulic fluids in forklift systems. Optimum bonding characteristics and special cover also make it the ideal hose for equipment operating in cold environments, while maintaining a high level of flexibility.

#### PERFORMANCE:

Meets or Exceeds the Performance Requirements of: SAE 100 R18.

#### TUBE:

Polyester elastomer.

#### REINFORCEMENT:

One or two braids of synthetic fibre.

#### COVER:

Special polyester, black with white ink-jet branding. Cover is perforated (pin-pricked).

#### FEATURES:

Special polyester cover resistant to low temperatures and harsh weather conditions. Optimum bonding between tube, braids and cover for tight bend radii without cover wrinkling.

#### TEMPERATURE RANGE:

From -55°C to +100°C (-67°F to +212°F)  
Air & Water +70 °C (+158 °F)  
For water, emulsions etc. see page 58.

#### WORKING PRESSURE:

Maximum working pressures are based on 4:1 safety factor (maximum working pressure to minimum burst pressure).

#### COUPLINGS:

**TP000 Series** (sizes -04 to -16) pages 304 to 316.  
Assembly Instructions pages 478.

TP3000 – ISOBARIC THERMOPLASTIC HOSE															
PART NO	HOSE SIZE	NOMINAL HOSE ID		NOMINAL HOSE OD		MAXIMUM WORKING PRESSURE		MINIMUM BURST PRESSURE		MINIMUM BEND RADIUS		AVERAGE WEIGHT		COUPLING SERIES	
		mm	inch	mm	inch	bar	psi	bar	psi	mm	inch	kg/m	lb/ft	ONE PIECE	
TP3004	6 -04	6,5	1/4	12,2	0.48	210	3000	840	12000	35	1.4	0,09	0.06	TP000	
TP3006	10 -06	9,7	3/8	16,6	0.65	210	3000	840	12000	45	1.8	0,16	0.11	TP000	
TP3008	12 -08	13,0	1/2	22,5	0.89	210	3000	840	12000	70	2.8	0,29	0.20	TP000	

Refer to the latest RYCO Crimp Charts for crimp diameter and mark lengths.





# TPGL

THERMOPLASTIC  
HIGH PRESSURE  
GREASELINE HOSE

**RECOMMENDED FOR:**

Thermoplastic constant pressure hose for high pressure greasing and lubrication systems.

**TUBE:**

White, oil resistant seamless thermoplastic polymer.

**REINFORCEMENT:**

One braid of synthetic fibre.

**COVER:**

Black, oil and abrasion resistant thermoplastic polymer. Cover is non-perforated.

**FEATURES:**

Polyester reinforcement for high pressure. Extremely compact and flexible, and highly kink resistant. Special low-friction smooth cover for easy installation and compact routing.

**TEMPERATURE RANGE:**

From -40°C to +100°C (-40°F to +212°F). For water, emulsions etc. see page 58.

**WORKING PRESSURE:**

Maximum working pressures are based on 4:1 safety factor (maximum working pressure to minimum burst pressure).

**COUPLINGS:**

**NON-SKIVE ONE-PIECE CRIMP**

**TG000 Series** (size -02) pages 321. Assembly Instructions pages 478.

**FIELD ATTACHABLE NON-SKIVE**

**6000 SERIES** insert (size -02) pages 355 to 385. **P000 Series** ferrule (size -02) page 353.

TPGL - THERMOPLASTIC GREASELINE HOSE																
PART NO	HOSE SIZE	NOMINAL HOSE ID		NOMINAL HOSE OD		MAXIMUM WORKING PRESSURE		MINIMUM BURST PRESSURE		MINIMUM BEND RADIUS		AVERAGE WEIGHT		ONE PC	FIELD ATT	
Hose	DN	Dash	mm	inch	mm	inch	bar	psi	bar	psi	mm	inch	kg/m	lb/ft	NON-SKIVE	
TPGL2	4	-02	4,0	0.16	8,3	0.33	250	3600	1000	14400	25	0.98	0,05	0.03	TG000	6000 (P000)

Refer to the latest RYCO Crimp Charts for crimp diameter and mark lengths.

### R4100N

FLEXIBLE GREASE GUN EXTENSIONS



**RECOMMENDED FOR:**

Rubber-covered hose for high pressure greasing and lubrication systems.

**TUBE:**

Black, oil resistant seamless synthetic rubber.

**REINFORCEMENT:**

One braid of high tensile steel wire.

**COVER:**

Black, oil and abrasion resistant synthetic rubber.

**FEATURES:**

Suit standard grease guns.

High tensile wire reinforcement for high pressure and durability.

Available in a variety of lengths

**TEMPERATURE RANGE:**

From -40°C to +100°C (-40°F to +212°F).

For water, emulsions etc. see page 58.

**WORKING PRESSURE:**

Maximum working pressures are based on 4:1 safety factor (maximum working pressure to minimum burst pressure).

R4100 - FLEXIBLE GREASE GUN EXTENSIONS				
PART NO	OVERALL LENGTH		END 1 CONNECTION	END 2 CONNECTION
Hose	mm	inch		
R4100	255	10	1/8" BSPT MALE	1/8" BSPT MALE
R4200	380	15	1/8" BSPT MALE	1/8" BSPT MALE
R4101	460	18	1/8" BSPT MALE	1/8" BSPT MALE
R4201	610	24	1/8" BSPT MALE	1/8" BSPT MALE
R4202	710	28	1/8" BSPT MALE	1/8" BSPT MALE



# HOSE PROTECTION

EXTRA ABRASION RESISTANT

FRAS - FLAME RESISTANT ANTI STATIC



RYCO QUALITY

BUNDLE MULTIPLE HOSES

RCS CROCSLEEVE SHOWN ABOVE  
THE LATEST IN RYCO'S SUPERIOR RANGE OF HOSE PROTECTION PRODUCTS



## HOSE PROTECTION – FS1072 FIRE SLEEVE

### FS1072 FIRE SLEEVE



MEETS OR EXCEEDS THE PERFORMANCE REQUIREMENTS OF:  
SAE AEROSPACE STANDARD AS 1072.

#### RECOMMENDED FOR:

Increasing service life of hoses used in hostile environments. It is a tough, flexible insulation, which not only protects from intense external radiant heat, but also sheds molten metal splash. Consequently, damage to hoses is reduced and service life is increased. In the event of fire, hoses carrying flammable or hazardous materials remain intact longer. It can also be used to protect cables, pipes and wire ropes. RYCO FS1072 FIRE SLEEVE can also be used to reduce heat loss from hoses.

#### CONSTRUCTION:

RYCO FS1072 FIRE SLEEVE is manufactured from high bulk braided glass fibre tubing, coated with silicon rubber. The “danger red” colour of the silicon rubber is due to heavy loading of iron oxide to improve heat resistance.

#### TEMPERATURE RANGE:

Continuous exposure:

from -54°C to +260°C (-65°F to +500°F)

15 to 20 minutes:

from +260°C to +1090°C (+500°F to +2000°F)

15 to 30 seconds:

from +1090°C to +1640°C (+2000°F to +3000°F)

#### TYPICAL PROPERTIES:

K Value in  $\frac{\text{BTU} \cdot \text{°F}}{\text{hr} \cdot \text{in}^2}$  1.20

K Value in  $\frac{\text{Cal}}{\text{cm} \cdot \text{sec} \cdot \text{cm}^2 \cdot \text{°C}}$  0.0004134

#### FLAME RESISTANCE:

7 seconds to extinguish with no afterglow.

#### ABRASION RESISTANCE:

Wyzenbeck 9500 cycles, 3.1/3 lb pressure, 6 lb tension using fine emery cloth.

#### OIL AND FLUID RESISTANCE:

Remains functional after immersion for 120hr @ 80°F in MIL-H-5606, MIL-L-6082, Skydrol 500 LD and Skydrol 500.

#### SIZE SELECTION:

FS1072 FIRE SLEEVE performs best when installed with a loose fit over a hose. However, some end users insist on a tight fit for the sake of appearance. To achieve this tight fit, use compressed air to expand FIRE SLEEVE as it is installed over the hose. Length of FIRE SLEEVE will shorten in length as it increases in diameter, so allow for some extra length to compensate for this.

For a loose fit, there is no hard and fast rule to relate the Nominal Inside Diameter of FIRE SLEEVE with the Nominal Outside Diameter of the hose being covered. However, it is important to take two factors into account: hose length and hose cover.

For hoses up to 5 metres (16 ft) long, use a Nominal Inside Diameter of FIRE SLEEVE 15% larger than the Nominal Outside Diameter of hose being covered. For hoses over 5 metres (16 ft) long, use a size 20% larger. Remember the FIRE SLEEVE must slide over the outside of the hose. The longer the hose, the tougher it is to install, especially if enough tolerance on a long hose has not been allowed.

As the FIRE SLEEVE must slide over the outside of the hose, the hose covering also requires special consideration. A hose with a rough rubber cover is more difficult to slide FIRE SLEEVE over than a hose with a smooth cover.

For hose covers that have a high co-efficient of friction, be sure to allow for greater tolerance between the Nominal Inside Diameter of FIRE SLEEVE and the Nominal Outside Diameter of the hose to be covered.

#### Sizes FS1072-08 to FS1072-104:

**Standard coil length is 15,24 metres (50 ft); or cut lengths. Lengths longer than 15,24 meters (50 ft) are also available, contact RYCO Customer Service.**

#### Sizes FS1072-80 and FS1072-104:

**Standard coil length is 5 metres (16.4 ft)**

FS1072 FIRE SLEEVE can be slit longitudinally to form a flat FIRE TAPE which can be wound around larger diameter hoses and secured with stainless steel ties or FSTAPE-16.

### FSTAPE-16

FSTAPE-16 is an iron oxide, red silicone rubber tape. It is designed to be, not only self-bonding and self-curing, but to also bond and cure onto FS1072 FIRE SLEEVE. It can be used to join separate sections of FIRE SLEEVE, as well as to repair any scuffed or nicked areas of FIRE SLEEVE. It can be used as an end sealant (instead of clamps) to prevent moisture and hydraulic oils wicking into the inner fibreglass braid.

**FSTAPE-16** is supplied in a roll 25 mm WIDE x 11 metres LONG x 0,5 mm THICK (1 inch x 36 ft x 0.02 inch)





## FS1072 FIRE SLEEVE SPECIFICATIONS

PART NO	NOMINAL ID		NOMINAL WALL THICKNESS		NOMINAL INSIDE FLAT DIMENSION		NOMINAL WEIGHT	
	A mm	A inch	B mm	B inch	C mm	C inch	kg/m	lb/ft
FS1072-08	12,7	0.50	4,3	0.17	20,0	0.79	0,19	0.13
FS1072-11	17,5	0.69	4,3	0.17	27,5	1.08	0,29	0.19
FS1072-14	22,2	0.87	4,4	0.17	34,9	1.37	0,28	0.19
FS1072-16	25,4	1.00	4,8	0.19	39,9	1.57	0,31	0.21
FS1072-18	28,6	1.13	4,7	0.19	46,6	1.84	0,37	0.25
FS1072-20	31,8	1.25	4,7	0.19	47,4	1.87	0,36	0.24
FS1072-22	34,9	1.38	4,8	0.19	54,8	2.17	0,43	0.29
FS1072-24	38,1	1.50	4,0	0.16	58,3	2.29	0,46	0.31
FS1072-30	47,6	1.87	4,0	0.16	74,8	2.93	0,54	0.36
FS1072-32	50,8	2.00	4,0	0.16	79,8	3.14	0,55	0.37
FS1072-40	63,5	2.50	4,1	0.16	94,2	3.71	0,84	0.56
FS1072-44	69,9	2.75	5,0	0.20	109,8	4.32	0,85	0.57
FS1072-64	102,0	4.02	5,0	0.20	160,2	6.32	1,07	0.72
FS1072-80	127,0	5.00	5,0	0.20	199,5	7.89	2,26	1.52
FS1072-104	165,0	6.50	5,0	0.20	259,2	10.21	2,86	1.92

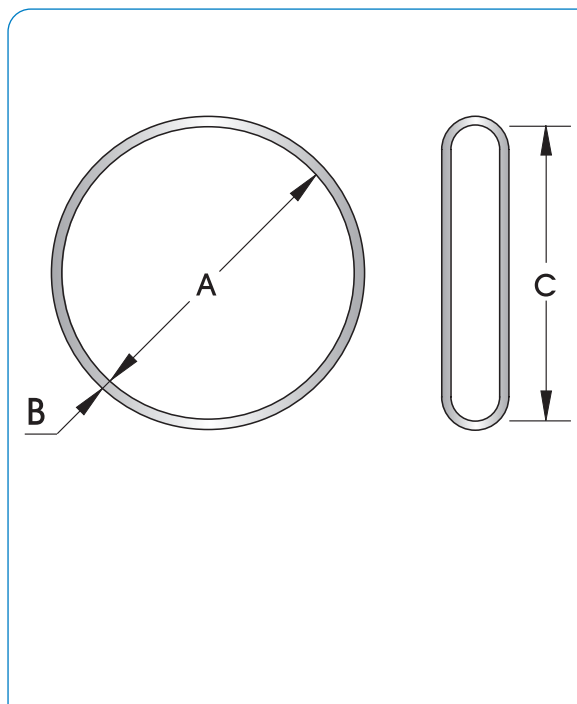

### HOSE NOMINAL OUTSIDE DIAMETER REFERENCE CHART

This chart may be used as a quick reference to assist in choosing correct size of Hose Protection. Dimensions are nominal only, and are in millimetres. Divide by 25.4 to convert to inches.

HOSE SIZE			HOSE SERIES																									
DN	INCH	DASH	T3000D/S	T3600C	T3600D/S	T4000D/S	T5000D/S	T6000D/S	H3000D/S	H4000D/S	H5000C	H5000D/S	H6000D/S	C6000D/S	DF1D	DF2D	DK1D/E/S	DK2D/E/S	EC1	EC2	ECP1	E1	E2	T1D/S	T1F	T2D/S		
3	1/8	-02																										
5	3/16	-03																			10,3			11,7	11,7			
6	1/4	-04	11,8	11,8	11,8	11,8	13,2	13,2							12,2	13,4	11,6	12,7	12,2	13,4	11,8	13,0	14,6	13,3	13,3	14,9		
8	5/16	-05	14,4	14,4	14,4	15,6	15,6	15,6							13,9	14,9	13,4	14,8	13,9	14,9	13,3	14,6	16,4	14,9	14,9	16,5		
10	3/8	-06	15,6	15,6	15,6	16,6	17,1	17,6		19,3		19,3	19,3		15,6	17,3	15,0	16,4	15,6	17,3	14,9	16,7	18,5	17,3	17,3	18,9		
12	1/2	-08	18,7	19,9	19,9	20,6	20,6			22,7		22,7	22,7	21,4	19,0	20,3	18,3	19,7	19,0	20,3	18,3	20,0	21,7	20,3	20,3	21,9		
16	5/8	-10	23,4	23,4	23,4	23,4				24,9		26,2	26,2	28,5	20,2	23,6	21,5	22,8	20,2	23,6		23,4	24,9	23,6	23,6	25,1		
19	3/4	-12	27,6	27,6	27,6	28,4				30,0	29,6	29,6	30,6	35,5	25,6	27,6	24,7	26,1	25,6	27,6		27,4	28,9	27,6	27,6	29,1		
25	1	-16	34,8	35	35,2					36,9	36,8	36,8	37,5		33,6	35,5	31,6	33,3	33,6	35,5		35,8	37,3	35,5	35,5	37,5		
31	1.1/4	-20								45,7	44,0	45,0	46,4			41,3	38,4	39,8							43,2		47,6	
38	1.1/2	-24								50,3	50,8		52,7	53,1											50,2		54,1	
51	2	-32								63,3	66,4		67,5	71,5											63,6		66,8	
63	2.1/2	-40																									80,1	
76	3	-48																									91,3	

INTRODUCTION

HOSE

COUPLINGS

ADAPTORS

TECHNICAL

# HOSE

## HOSE PROTECTION – FS1072 FIRE SLEEVE

HOSE SIZE																										
DN	INCH	DASH	T2C	TX2AD	H12D/S	R4SHD	R4SPD	TJ2D	R0P1	R0P2	R0P5	R0P6	D2B	T5	MS1000	CS1000	BT1	SW	JS4000/G	JS4000BX/GX	JS6000/G	JS6000BX/GX	SRF	SRX	RTH1	
3	1/8	-02																								
5	3/16	-03																								
6	1/4	-04	15,0					14,9	13,4	15,0	13,2	12,3		13,2			13,3		11,5	12,6	12,4	13,5			9,4	
8	5/16	-05	16,6					18,9	15,0	16,6	14,8	13,9		14,8			14,9		13,1	14,2	14,5	15,6				
10	3/8	-06	19,0		19,3		20,9		17,4	19,0	17,2	15,5		17,2			17,3	21,5	15,3	16,4	16,3	17,4			11,7	
12	1/2	-08	22,2	22,0	22,7		24,3		20,5	22,0	19,4	19,0		19,4	18,5	18,5	20,3	24,6	18,3	19,4	19,3	20,4			15,4	
16	5/8	-10	25,2	25,2	26,2		27,8		23,7	25,2	23,4	22,6		23,4	22,1	22,1	23,6								18,4	
19	3/4	-12	29,1	29,1	30,0	31,8	31,8		27,6	29,1	27,4	25,8		27,4	25,8	25,8	27,6	31,9					31,5	29,6	22,1	
25	1	-16	37,2	37,7	37,4	37,9	38,6		35,7	37,7	31,4			31,4	32,5	32,5	35,5	37,6					40,0	36,2	28,6	
31	1.1/4	-20	47,4		45,7	44,4				48,0	38,1		40,4	38,1	39,5	39,5							46,5	44,0		
38	1.1/2	-24	53,8		53,0	52,4				54,4	44,5		48,0	44,5	46,0	46,0							53,1	49,4		
51	2	-32	66,7		66,0	66,8				67,3	56,3		62,0	56,3	59,1	59,1							65,5	63,8		
63	2.1/2	-40			82,6																			76,5		
76	3	-48																						89,9		

HOSE SIZE			HOSE SERIES												
DN	INCH	DASH	PL1	PL1D	M1	MP1	M2	M2G	TP7, TP7N	TP7T, TP7TN	TP8, TP8N	TP8T, TP8TN	TP3000	TPGL	
3	1/8	-02												8,3	
5	3/16	-03							9,6						
6	1/4	-04	14,4	12,7	12,7	13,5	14,3	14,3	12,2	12,2	11,5	11,5	12,2		
8	5/16	-05	13,9	14,3	14,3				14,3	14,3					
10	3/8	-06	17,8	15,9	15,9	17,5	19,0	19,0	16,0	16,0	15,5	15,5	16,6		
12	1/2	-08	21,8	19,8		21,4	23,8	23,8	20,3	20,3	19,9	19,9	22,5		
16	5/8	-10	25,9	23,0		25,4									
19	3/4	-12	29,6	26,4		28,6	31,7	31,7	27,1						
25	1	-16				37,3			34,0						
31	1.1/4	-20				43,9									
38	1.1/2	-24													
51	2	-32													
63	2.1/2	-40													
76	3	-48													

## RCS CROCSLEEVE FLAME RESISTANT ANTI-STATIC



INTRODUCTION

HOSE

COUPLINGS

ADAPTORS

TECHNICAL

### RECOMMENDED FOR:

Hose burst and pinhole protection. Protection of individual hoses from severe abrasion. Provides a cost effective method of bundling hoses together, while providing abrasion resistance to the bundle. When abrasion occurs, the thousands of tiny filaments in the sleeve bulk up, to continually renew the surface.

### CONSTRUCTION:

Densely woven, polyamide tubular sleeve. Black or Red colour. CROCSLEEVE is not affected by exposure to air, water, hydraulic oil and many other fluids. The inside bore of the CROCSLEEVE is smooth, allowing hose to move inside the sleeve, and allowing easy installation.

### FRAS - FLAME RESISTANCE AND ANTI-STATIC:

Flame Resistant and Anti-Static - FRAS. Electrical conductivity is 3 to 5 MΩ/m when subjected to 500 Volts DC.

### TEMPERATURE RANGE:

From - 50°C to + 121°C (- 58°F to + 250°F).

### SIZE SELECTION:

Choose a size that is slightly larger than the hose or hoses to be sleeved - recommended size is 50% larger than nominal Hose OD (see chart on page 151). If CROCSLEEVE is to be installed onto fitted hose assemblies, allow for the maximum outside profile of the hose fittings.

### ASSEMBLY INSTRUCTIONS:

1. Cut the CROCSLEEVE to length.
2. The loose fibres of the cut edges can be sealed with a heat gun or hot knife, to prevent fraying.
3. Install over hoses or hose assemblies.
4. Secure in place using adhesive-lined heat shrink tubing.

## RCS CROCSLEEVE SPECIFICATIONS

### CROCSLEEVE DIMENSIONS

PART NO		NOMINAL ID		NOMINAL FLAT ID		NOMINAL FLAT OD		NOMINAL WEIGHT	
Black	RED	A mm	A inch	B mm	B inch	C mm	C inch	kg/m	lb/ft
RCSB-20	RCSR-20	20	0.79	31	1.22	34	1.34	0,039	0.026
RCSB-23	RCSR-23	23	0.91	36	1.42	39	1.54	0,044	0.030
RCSB-27	RCSR-27	27	1.06	42	1.65	45	1.77	0,052	0.035
RCSB-31	RCSR-31	31	1.22	49	1.93	52	2.05	0,060	0.040
RCSB-36	RCSR-36	36	1.42	54	2.13	57	2.24	0,065	0.044
RCSB-44	RCSR-44	44	1.73	69	2.72	72	2.83	0,082	0.055
RCSB-47	RCSR-47	47	1.85	74	2.91	77	3.03	0,086	0.058
RCSB-55	RCSR-55	55	2.17	86	3.39	89	3.50	0,102	0.068
RCSB-60	RCSR-60	60	2.36	94	3.70	97	3.82	0,111	0.074
RCSB-66	RCSR-66	66	2.60	104	4.09	107	4.21	0,122	0.082
RCSB-73	RCSR-73	73	2.87	115	4.53	118	4.65	0,135	0.091
RCSB-93	RCSR-93	93	3.66	146	5.75	149	5.87	0,170	0.114
RCSB-112	RCSR-112	112	4.41	176	6.93	179	7.05	0,206	0.138
RCSB-129	RCSR-129	129	5.08	202	7.95	205	8.07	0,360	0.241

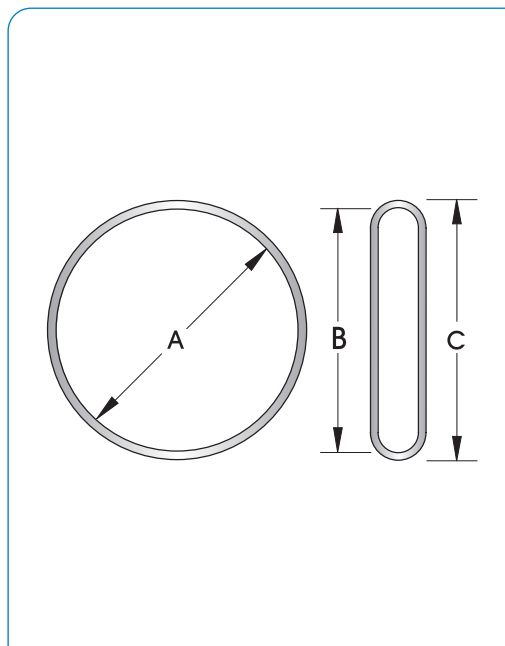

NOTE: In order to function as a burst diffuser, the RCS CROCSLEEVE size recommendations stated in this chart are approximately 50% larger than the corresponding Hose OD.

# MDG 41 SAFE

# HOSE

## HOSE PROTECTION – RCS CROCSLEEVE

**CROCSLEEVE SIZE VERSUS HOSE AND DASH SIZE SELECTION TABLE**

	T3000D/S	T3600D/S/C	T4000D/S	T5000D/S	T6000D/S	H3000D/S	H4000D/S	H5000D/S/C	H6000D/S	C6000D/S	DF1D	DF2D	DK1D/E/S	DK2D/E/S	EC1	EC2	ECP1	E1	E2
Part No.	Dash Size																		
RCSB-20	-04	-04	-04	-04	-04								-04	-04	-04	-04	-03,-04	-04	
RCSB-23	-05	-05	-05	-05	-05						-04,-05	-04,-05	-05	-05,-06	-05,-06	-05	-05,-06	-05	-04
RCSB-27	-06	-06	-06	-06	-06						-06	-06	-06	-08		-06	-07	-06	-05,-06
RCSB-31	-08	-08	-08	-08			-06	-06	-06	-08	-08,-10	-08	-10	-10	-08,-10	-08		-08	
RCSB-36	-10	-10	-10	-10	-08		-08	-08	-08		-12	-10	-12	-12		-10		-10	-08
RCSB-44	-12	-12	-12	-12			-10	-10	-10	-12,-16	-16	-12		-16	-12	-12		-12,-16	-10
RCSB-47							-12	-12	-12				-16	-20		-16			-12
RCSB-55	-16	-16					-16	-16	-16			-16			-16				
RCSB-60												-20	-20						-16
RCSB-66							-20	-20											
RCSB-73							-20		-20										
RCSB-93							-24	-24	-24	-24									
RCSB-112							-32	-32	-32	-32									
RCSB-129																			

NOTE: In order to function as a burst diffuser, the RCS CROCSLEEVE size recommendations stated in this chart are approximately 50% larger than the corresponding Hose OD.

**CROCSLEEVE SIZE VERSUS HOSE AND DASH SIZE SELECTION TABLE**

	T1D/S	T1F	T2D/S	TX2AD	H12D/S	R4SHD	R4SPD	TJ2D	RQP1	RQP2	RQP5	RQP6	D2B	T5	MS1000	CS1000	BT1	SW	JS4000/G
Part No.																			
RCSB-20	-03,-04	-03,-04							-04	-04	-04	-04		-04			-04		-04
RCSB-23	-05	-05	-04					-04	-05	-05	-05	-05,-06		-05			-05		-05,-06
RCSB-27	-06	-06	-05,-06					-06	-06	-06	-06			-06	-08	-08	-06		-08
RCSB-31	-08	-08	-08		-06		-06		-08		-08	-08		-08		-10	-08	-06	
RCSB-36	-10	-10	-10	-08	-08		-08		-10	-08,-10	-10	-10,-12		-10	-10	-12	-10	-08	
RCSB-44	-12	-12	-12	-10	-10		-10		-12	-12	-12,-16			-12	-12		-12		
RCSB-47				-12	-12	-12	-12							-16	-16	-16	-16	-12	
RCSB-55	-16	-16	-16	-16		-16			-16	-16				-20				-12	
RCSB-60					-16		-16						-20		-20	-20		-16	
RCSB-66	-20	-20				-20								-24					
RCSB-73	-24	-24	-20		-20		-20			-20			-24		-24	-24			
RCSB-93	-32	-32	-24		-24	-24	-24			-24			-32	-32	-32	-32			
RCSB-112			-32		-32	-32	-32			-32									
RCSB-129			-40		-40														

NOTE: In order to function as a burst diffuser, the RCS CROCSLEEVE size recommendations stated in this chart are approximately 50% larger than the corresponding Hose OD.



## CROCSLEEVE SIZE VERSUS HOSE AND DASH SIZE SELECTION TABLE

Part No.	JS4000BX/GX	JS6000/G	JS6000BX/GX	SRF	SRX	RTH1	PL1	PL1D	M1	MP1	M2/G	TP7, TP7N	TP7T, TP7TN	TP8, TP8N	TP8T, TP8TN	TP3000	TPGL
RCSB-20	-04	-04	-04				-04	-04	-04	-04		-03, -04	-04	-04	-04	-04	-02
RCSB-23	-05	-05	-05				-05, -06	-05, -06	-05, -06	-06	-04	-05, -06	-05, -06	-06	-06	-06	
RCSB-27	-06	-06	-06									-08					
RCSB-31	-08	-08	-08				-08	-08		-08	-06		08	-08	-08	-08	
RCSB-36							-10	-10		-10	-08	-12					
RCSB-44				-12	-12	-12	-12	-12		-12	-12						
RCSB-47												-16					
RCSB-55						-16				-16							
RCSB-60				-16	-16												
RCSB-66				-20	-20	-20				-20							
RCSB-73																	
RCSB-93				-24	-24	-32											
RCSB-112				-32	-32	-40											
RCSB-129						-48											

NOTE: In order to function as a burst diffuser, the RCS CROCSLEEVE size recommendations stated in this chart are approximately 50% larger than the corresponding Hose OD.

## CROCSLEEVE - SAFETY FIRST

DESIGN FEATURES	BENEFITS
<b>GREATER STRENGTH</b>	CROCSLEEVE is made from high density PA (polyamide) for greater strength
<b>FLAME RESISTANT - ABRASION RESISTANT</b>	CROCSLEEVE is Flame Resistant and Anti-Static - FRAS
<b>BURST RESISTANT</b>	CROCSLEEVE is very resistant to hose burst
<b>PIN HOLE RESISTANT</b>	CROCSLEEVE is very resistant to hose pin holes
<b>LEAK RESISTANT</b>	CROCSLEEVE will allow pressure build up of up to 7 bar (100 psi)
<b>STABLE</b>	CROCSLEEVE is stable and has great resistance to sun, atmospheric agents and ageing
<b>NON-TOXIC</b>	CROCSLEEVE is non toxic
<b>TOUGH</b>	CROCSLEEVE is super tough
<b>COLOURS</b>	CROCSLEEVE comes in BLACK (RCSB) and RED (RCSR)
<b>EASY INSTALLATION</b>	CROCSLEEVE has a smooth bore providing easy installation of the hose

CHEMICALLY COMPATIBLE	Compatibility	Compatibility	Compatibility
Acetone	Very Good	Ether	Very Good
Alcohols	Very Good	Gasoline	Very Good
Bacterium	Very Good	Ionic Metallic Solutions	Very Good
Benzene	Very Good	Mineral Oil	Very Good
Carbon Tetrachloride	Very Good	Moths	Very Good
Chlorine Based Solvents	Very Good	Mould	Very Good
Diluted Acids	Good	Oil	Very Good
Diluted Bases	Very Good	Vegetable Oil	Very Good

INTRODUCTION

HOSE

COUPLINGS

ADAPTORS

TECHNICAL

# HOSE

## HOSE PROTECTION – RAWHIDE NYLON HOSE SLEEVE

# RH

RAWHIDE  
NYLON HOSE SLEEVE



### RECOMMENDED FOR:

Protection of individual hoses from severe abrasion. Provides a cost effective method of bundling hoses together, while providing abrasion resistance to the bundle. When abrasion occurs, the thousands of tiny filaments in the sleeve bulk up, to continually renew the surface.

### CONSTRUCTION:

Densely woven, multi-filament nylon, tubular sleeve. Black colour. Nylon is not affected by exposure to air, water, hydraulic oil and many other fluids. The inside bore of the sleeve is smooth, allowing hose to move inside the sleeve, and allowing easy installation.

### FLAME RESISTANCE:

Meets Flame Resistant Designation "U.S. MSHA" of the U.S. Department of Labor, Mine Safety and Health Administration.

### TEMPERATURE RANGE:

From - 50°C to + 121°C (- 58°F to + 250°F).

### SIZE SELECTION:

Choose a size that is slightly larger than the hose or hoses to be sleeved (see chart on page 154). If sleeve is to be installed onto fitted hose assemblies, allow for the maximum outside profile of the hose fittings.

### ASSEMBLY INSTRUCTIONS:

1. Cut the Nylon Hose Sleeve to length.
2. The loose fibres of the cut edges can be sealed with a heat gun or hot knife, to prevent fraying.
3. Install over hoses or hose assemblies.
4. Secure in place using cable ties, band clamps or hose clamps.

### STANDARD COIL LENGTHS:

91,4 metre (300 ft) long coils; or cut lengths.



## RH RAWHIDE SPECIFICATIONS

### RAWHIDE NYLON HOSE SLEEVE

PART NO	NOMINAL ID		NOMINAL WALL THICKNESS		NOMINAL INSIDE FLAT DIMENSION		NOMINAL WEIGHT	
	A mm	A inch	B mm	B inch	C mm	C inch	kg/m	lb/ft
RH-23	22,9	0.90	2,3	0.09	29,8	1.41	0,06	0.03
RH-27	26,9	1.06	2,3	0.09	39,8	1.67	0,07	0.04
RH-31	31,0	1.22	2,3	0.09	49,9	1.92	0,08	0.05
RH-36	36,0	1.42	2,5	0.10	56,6	2.23	0,09	0.06
RH-46	46,0	1.81	2,5	0.10	72,1	2.84	0,12	0.08
RH-56	55,6	2.19	2,5	0.10	87,4	3.44	0,15	0.10
RH-61	60,5	2.38	2,5	0.10	95,0	3.74	0,16	0.11
RH-67	66,8	2.63	2,5	0.10	104,6	4.12	0,17	0.12
RH-73	73,2	2.88	2,5	0.10	115,1	4.53	0,19	0.13
RH-93	93,0	3.66	2,5	0.10	146,1	5.75	0,25	0.17

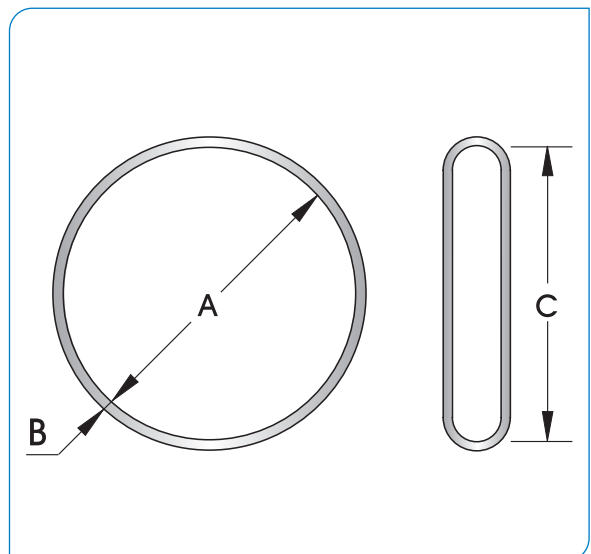

NOTE: In order to function as a burst diffuser, the RCS CROCSLEEVE size recommendations stated in this chart are approximately 50% larger than the corresponding Hose OD.

## RSG

POLYETHYLENE SPIRAL GUARD  
RSG (BLACK), RSGY (YELLOW),  
RSGF (FRAS)



INTRODUCTION

### RECOMMENDED FOR:

Lightweight, cost-effective protection of hoses and cables from abrasion and impact. It can also be used to bundle hoses together in groups. RSGF meets Flame Resistance Designation "U.S. MSHA" of the US Department of Labor, Mine Safety and Health Administration.

### CONSTRUCTION:

Polyethylene plastic spiral, with rounded edges to protect hose cover. RSG Black; RSGY Yellow; RSGF FRAS (Dark Grey). Polyethylene is not affected by exposure to air, water, hydraulic oil and many other fluids.

### TEMPERATURE RANGE:

From -40°C to +120°C (-40°F to +248°F).

### ASSEMBLY INSTRUCTIONS:

RYCO Spiral Guard can easily be applied after hose assembly because of its spiral form. Place one end of completed hose assembly in a vice. Wrap coil onto hose. It is recommended to choose RYCO Spiral Guard size so that it is a tight fit on the hose.

This will keep the Spiral Guard in place on the hose. The Spiral Guard expands to fit the hose or hose bundle. Allow extra length of Spiral Guard to allow for this expansion.

### SIZE SELECTION:

The tables below show RYCO Spiral Guard size selection for a tight fit on the hose. Due to the Spiral Guard expanding to fit the hose, extra length of Spiral Guard must be allowed. This extra length can be estimated as follows:

T26A Nominal OD = 18,9 mm (see chart on page 151)  
RSG-20L Nominal ID = 15,0 mm (from chart below)  
Estimated length of RSG-20L to cover 2,3 metres of T26A

$$= \frac{18,9}{15,0} \times 2,3 \text{ m} = 2,90 \text{ metres}$$

### HOW TO ORDER:

Complete the Part Number: **RSG-16L**, **RSGY-75L**, **RSGF-50L** etc.

Sizes -16L to -90L: 20 m (65.6 ft) coils or cut to length.

Size -110L: 10 m (32.8 ft) coils or cut to length.

HOSE

COUPLINGS

ADAPTORS

TECHNICAL

SPIRAL GUARD					HOSE SERIES																		
DASH SIZE	NOMINAL ID		NOMINAL OD		T3000D/S	T3600C	T3600D/S	T4000D/S	T5000D/S	T6000D/S	H3000D/S	H4000D/S	H5000C	H5000D/S	H6000D/S	C6000D/S	DF1D	DF2D	DK1D/E/S	DK2D/E/S	EC1/2	ECP1	E1
	MM	INCH	MM	INCH																			
-12L	9,0	0.35	13,0	0.51	-4	-4	-4	-4	-4								-4	-4	-4	-4	-3,-4		
-16L	12,0	0.47	16,5	0.65	-5,-6	-5,-6	-5,-6	-5	-5	-4,-5							-5,-6	-4,-5	-5,-6	-5	-5,-6	-5	-4,-5
-20L	15,0	0.59	20,0	0.79	-8		-8	-6,-8	-6,-8	-6		-6	-6	-6			-8	-6	-8	-6	-8	-6	-6
-25L	19,0	0.75	24,5	0.96	-10	-8,-10	-10	-8,-10		-8		-8	-8	-8	-8		-10	-8,-10	-10	-8,-10	-10	-7	-8,-10
-32L	23,0	0.91	30,0	1.18	-12	-12	-12	-12	-10,-12			-10,-12	-12	-10,-12	-10,-12	-12	-12	-12	-12	-12	-12		-12
-40L	30,5	1.20	39,0	1.54	-16	-16	-16		-16			-16	-16	-16	-16	-16	-16	-16	-16	-16	-16		-16
-50L	38,0	1.50	46,5	1.83							-20	-20	-20	-20	-20			-20		-20			
-63L	47,0	1.85	58,0	2.28							-24	-24		-24	-24								
-75L	61,0	2.40	73,0	2.87							-32	-32		-32	-32								
-90L	70,5	2.78	84,5	3.33																			
-110L	84,0	3.31	99,0	3.90																			

# HOSE

## HOSE PROTECTION – RSG/RSGY/SGF SPIRAL

### RSG

POLYETHYLENE SPIRAL GUARD  
RSG (BLACK), RSGY (YELLOW),  
RSGF (FRAS)

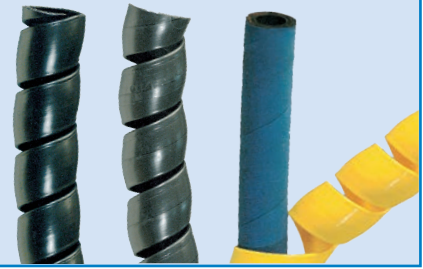

SPIRAL GUARD	HOSE SERIES (CONT)																		
--------------	--------------------	--	--	--	--	--	--	--	--	--	--	--	--	--	--	--	--	--	--

DASH SIZE	NOMINAL ID		NOMINAL OD		E2	T1D/S	T1F	T2D/S	T2C	TXA2D	H12D/S	R4SPD	R4SPD	TJ2D	RQP1	RQP2	RQP5	RQP6	D2B	T5	MS1000	CS1000	BT1
	MM	INCH	MM	INCH																			
-12L	9,0	0.35	13,0	0.51		-3	-3								-4		-4	-4					
-16L	12,0	0.47	16,5	0.65	-4	-4,-5	-4,-5	-4	-4					-4	-5	-4	-5	-5,-6		-4,-5			-4,-5
-20L	15,0	0.59	20,0	0.79	-5,-6	-6	-6	-5,-6	-5,-6		-6	-6		-5	-6,-8	-5,-6	-6,-8	-8		-6,-8	-8	-8	-6,
-25L	19,0	0.75	24,5	0.96	-8	-8,-10	-8,-10	-8	-8	-8	-8	-8		-10	-8,-10	-10	-10	-10		-10	-10	-10	-8,-10
-32L	23,0	0.91	30,0	1.18	-10,-12	-12	-12	-10,-12	-10,-12	-10,-12	-10	-10		-12	-12	-12	-12	-12		-12	-12	-12	-12
-40L	30,5	1.20	39,0	1.54	-16	-16	-16	-16	-16	-16	-12,16	-12,16	-12,-16		-16	-16	-16,-20			-16,-20	-16	-16	-16
-50L	38,0	1.50	46,5	1.83		-20,			-20		-20	-20	-20		-20	-24			-20	-24	-20,-24	-20,-24	
-63L	47,0	1.85	58,0	2.28		-24		-20,-24	-20,-24		-24	-24	-24			-24	-32		-24	-32	-32	-32	
-75L	61,0	2.40	73,0	2.87		-32		-32	-32		-32	-32	-32			-32			-32				
-90L	70,5	2.78	84,5	3.33							-40												
-110L	84,0	3.31	99,0	3.90																			

DASH SIZE	NOMINAL ID		NOMINAL OD		SW	JS4000/G	JS4000/GX/BX	JS6000/G	JS6000/GX/BX	SRF	SRX	RTH1	PL1	PL1D	M1	MP1	M2/M2G	TP7/N,T/TN TP7N	TP8T, TP8TN	TP3000	TP6L	
	MM	INCH	MM	INCH																		
-12L	9,0	0.35	13,0	0.51		-4	-4	-4				-4,-6		-4	-4			-4	-4	-4	-2	
-16L	12,0	0.47	16,5	0.65		-5,-6	-5	-5	-4,-5			-8	-4	-5,-6	-5,-6		-4	-5,-6	-6	-6		
-20L	15,0	0.59	20,0	0.79		-8	-6,-8	-6,-8	-6			-10	-5	-8		-4,-6	-6	-8	-8			
-25L	19,0	0.75	24,5	0.96	-6				-8			-12	-6,-8	-10		-8,-10	-8			-8		
-32L	23,0	0.91	30,0	1.18	-8							-12	-16	-10	-12		-12	-12	-12			
-40L	30,5	1.20	39,0	1.54	-12,-16							-12	-16			-16		-16				
-50L	38,0	1.50	46,5	1.83								-16	-20			-20						
-63L	47,0	1.85	58,0	2.28								-20,-24	-24									
-75L	61,0	2.40	73,0	2.87								-32	-32									
-90L	70,5	2.78	84,5	3.33								-40										
-110L	84,0	3.31	99,0	3.90								-48										



## RWA WIRE ARMOUR

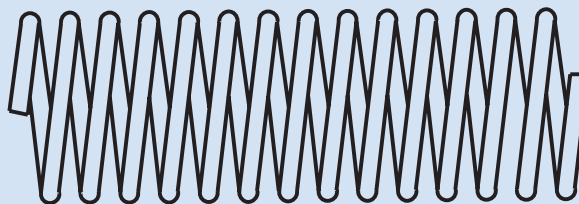

INTRODUCTION

HOSE

COUPLINGS

ADAPTORS

TECHNICAL

### RECOMMENDED FOR:

Protection for Hose Cover in arduous operating conditions; especially against abrasion and deep gouges, thus prolonging the life of the Hose.

### CONSTRUCTION:

Spring Steel Wire; galvanised for corrosion protection.

### TEMPERATURE RANGE:

Suitable for use with all RYCO Hoses at their published temperature ranges.

### ASSEMBLY INSTRUCTIONS:

1. Slide RWA Wire Armour over hose after first end of hose assembly is completed.
2. Then complete second end of hose assembly.

### STANDARD LENGTH:

6 metres (19.7 ft) in all sizes.

WIRE ARMOUR			HOSE SERIES																				
PART NO	NOMINAL ID		T3000D/S	T3600C	T3600D/S	T4000D/S	T5000D/S	T6000D/S	H3000D/S	H4000D/S	H5000C	H5000D/S	H6000D/S	C6000D/S	DF1D	DF2D	DK1D/E/S	DK2D/E/S	EC1	EC2	ECP1	E1	E2
	MM	INCH																					
RWA-12	12	0.47		-4													-4						
RWA-16	16	0.63	-4,-5	-5,-6	-4,-5	-4	-4	-4							-4,-5	-4,-5	-5,-6	-4,-5	-4,-5	-4,-5		-4,-5	-4
RWA-20	20	0.78	-6		-6	-5,-6	-5,-6	-5,-6							-6,-8	-6	-8	-6	-6	-6		-6	-5,-6
RWA-21	21	0.83	-8	-8	-8				-6		-6	-6			-10	-8		-8	-8,-10	-8		-8	
RWA-23	23	0.91				-8	-8	8					-8				-10	-10					-8
RWA-27	27	1.06	-10	-10	-10	-10	-10		-8,-10		-8	-8			-12	-10	-12	-12	-12	-10		-10	-10
RWA-30	30	1.19	-12	-10	-12	-12	-12				-10	-10	-12			-12	-12			-12		-12	
RWA-31	31	1.22								-12	-12												-12
RWA-34	34	1.34							-12			-12					-16	-16					
RWA-39	39	1.52	-16	-16	-16				-16	-16	-16	-16	-16	-16	-16	-16	-20		-16	-16		-16	-16
RWA-41	41	1.61																-20					
RWA-49	49	1.93							-20	-20	-20	-20	-20			-20							
RWA-56	56	2.2							-24	-24		-24	-24										
RWA-61	61	2.4																					
RWA-68	68	2.68							-32	-32													
RWA-75	75	2.95										-32	-32										

# HOSE

## HOSE PROTECTION – RWA WIRE ARMOUR

**RWA**  
WIRE ARMOUR

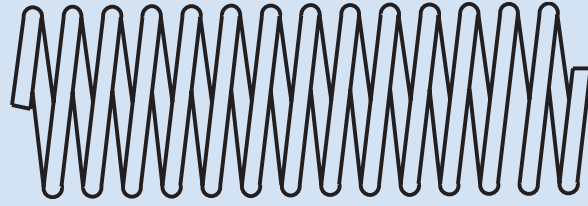

### WIRE ARMOUR

PART NO	NOMINAL ID		T1D/S	T1F	T2D/S	T2C	TXA2D	H12D/S	R4SHD	R4SPD	TJ2D	RQP1	RQP2	RQP5	RQP6	D2B	T5	MS1000	CS1000	BT1	SW	JS4000/GX/BX
	MM	INCH																				
RWA-12	12	0.47																				
RWA-16	16	0.63	-4,-5		-4							-4,-5	-4	-4,-5	-4,-5		-4,-5			-4,-5		-4,-5
RWA-20	20	0.78	-6		-5	-4,-5					4	-6	-5	-6	-6		-6			-6		-6
RWA-21	21	0.83			-6	-6					-5		-6	-8	-8		-8	-8	-8			-8
RWA-23	23	0.91	-8		-8		-8	-6		-6		-8	-8							-8	-6	
RWA-27	27	1.06	-10			-8,-10		-8		-8		-10		-10	-10		-10	-10,-12	-10,-12	-10	-8	
RWA-30	30	1.19	-12		-10		-10	-10		-10		-12	-10	-12	-12		-12			-12		
RWA-31	31	1.22			-12	-12	-12						-12									
RWA-34	34	1.34						-12	-12	-12				-16			-16	-16	-16			-12
RWA-39	39	1.52	-16			-16			-16											-16	-16	
RWA-41	41	1.61			-16		-16	-16		-16			-16	-20		-20	-20	-20	-20			
RWA-49	49	1.93	-20		-20	-20	-20	-20	-20			-20	-24				-24	-24	-24			
RWA-56	56	2.2	-24		-24	-24		-24	-24	-20			-24			-24						
RWA-61	61	2.4								-24				-32			-32	-32	-32			
RWA-68	68	2.68	-32		-32	-32		-32					-32			-32						
RWA-75	75	2.95							-32	-32												

PART NO	NOMINAL ID		JS4000/GX/BX	JS6000/G	JS6000/GX/BX	SRF	SRX	RTH1	PL1	PL1D	M1	MP1	M2	M2G	TP7, TP7N	TP7T, TP7TN	TP8, TP8N	TP8T, TP8TN	TP3000	
	MM	INCH																		
RWA-12	12	0.47						-4							-3					
RWA-16	16	0.63	-4,-5	-4,-5	-4			-6,-8	-4,-5	-4,-5	-4,-5	-4	-4	-4	-4,-5	-4,-5	-4	-4	-4	
RWA-20	20	0.78	-6	-6	-5,-6			-6,-8	-6	-6	-6	-6			-6	-6	-6	-6	-6	
RWA-21	21	0.83	-8	-8	-8			-10		-8			-6	-6			-8	-8		
RWA-23	23	0.91						-10				-8			-8	-8				
RWA-27	27	1.06						-12	-12	-10		-10	-8	-8					-8	
RWA-30	30	1.19					-12			-12		-12			-12					
RWA-31	31	1.22						-16												
RWA-34	34	1.34											-12							
RWA-39	39	1.52				-12	-16								-16					
RWA-41	41	1.61				-16														
RWA-49	49	1.93				-20	-20													
RWA-56	56	2.2				-24	-24													
RWA-61	61	2.4																		
RWA-68	68	2.68				-32	-32													
RWA-75	75	2.95																		

## RHYS PACKAGING SLEEVE



INTRODUCTION

### RECOMMENDED FOR:

Packaging and protection of hose assemblies, in transit and in storage. RYCO RHYS Packaging Sleeve is installed over the finished hose assembly. The ends may be heat sealed, or folded over and stapled, or taped closed.

### CONSTRUCTION:

Heavy gauge low density polyethylene clear plastic tubing; printed at intervals with “RYCO” logo, and incorporating an area for the hose assembly Part Number to be written.

### ASSEMBLY INSTRUCTIONS:

1. Select correct size of RYCO RHYS Packaging Sleeve. It must be large enough to allow for the maximum outside profile of the hose couplings.
2. Two sizes are available:
3. RHYS-75 suits most hoses up to -16 (1”) hose bore.
4. RHYS-125 suits most hoses from -16 to -32 (1” to 2”) hose.
5. If required, write the hose assembly Part Number onto the Packaging Sleeve using a ball point pen.
6. Slide the hose assembly into the RHYS Packaging Sleeve.
7. Trim Packaging Sleeve to length, and seal ends.

### STANDARD COIL LENGTHS:

350 metres (1,150 feet).

HOSE

COUPLINGS

ADAPTORS

TECHNICAL

## RHYS HOSE ASSEMBLY PACKAGING SLEEVE SPECIFICATIONS

PART NO	PACKAGING SLEEVE							
	NOMINAL ID		NOMINAL WALL THICKNESS		NOMINAL INSIDE FLAT DIMENSION		NOMINAL WEIGHT	
	A mm	A inch	B mm	B inch	C mm	C inch	kg/m	lb/ft
RHYS-75	48	1.9	0,15	0.006	75	3.0	0,021	0.014
RHYS-125	79	3.1	0,15	0.006	125	5.0	0,035	0.023

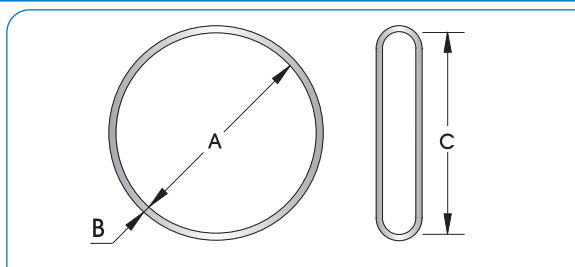

# HOSE

## HOSE PROTECTION – 750/760 SPRING GUARD

### 750/760 SPRING GUARD

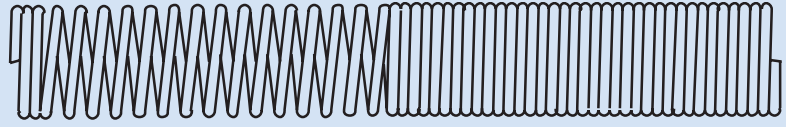

#### RECOMMENDED FOR:

TJ24D and TJ26D Specialist Jacking Hose Assemblies, to control bend radius at end of hoses to avoid excessive strain on hose couplings. Can also be used with **E24, E26, RQP24, RQP26, T24C, T24D, T24S, T26C, T26D** and **T26S** Hoses. Can be used with **L000** Series Field Attachable and **T2000** Series BITELOK Couplings.

**750** Suits some -4 (1/4") and -6 (3/8") hoses

**760** Suits some -6 (3/8") hoses

#### CONSTRUCTION:

Spring Steel Wire; galvanised for corrosion protection.

#### ASSEMBLY INSTRUCTIONS:

Slide Spring Guards over the hose before assembling hose ends. After ends are assembled, twist and push Spring Guards onto the ferrules. The close pitched end of the Spring Guard goes over the ferrule, and the wide pitched end goes over the hose (as depicted in below image).





## GRAM

GRAM LABEL

**000PN1806280001**

RYCO HYDRAULICS PTY LTD  
28 JUN 2018  
GRAM PUMP  
HAT5008D000123  
H123-01  
RYCO HYDRAULICS PTY LTD

**RECOMMENDED FOR:**

Permanent identification of hose assemblies. QRAM Hose Tags enable hose assembly information to be attached to the hose assembly in a cost effective manner.

Information can be printed on the Hose Tag prior to being attached to the hose. When the Hose Tag is wrapped on the hose, a clear panel at the end of the tag wraps over to protect the written or printed information.

Hose Tag remains in position on the hose due to the adhesive backing, and the Hose Tag bends with the hose, ensuring that flexibility is not affected.

The slim profile of the attached Hose Tag reduces the risk of accidental removal. Hose Tag does not damage or cut the cover of the hose.

**CONSTRUCTION:**

Heat, oil, ozone, sunlight, and weather resistant high performance plastic.

Adhesive-backed for permanent attachment to the hose assembly. Area to write or print information, with a clear panel that wraps over to protect the hose assembly identification information.

**TEMPERATURE RANGE:**

Suitable for use with all RYCO Hoses at their published temperature ranges.

**ASSEMBLY INSTRUCTIONS:**

1. Two sizes are available:
2. QRAM-S suits hose sizes -04 to -20 (1/4" to 1 1/4").
3. QRAM-L suits hose sizes -12 to -32 (3/4" to 2").
4. Remove the release paper from the back of the Hose Tag to expose the adhesive.
5. While ensuring that the Hose Tag is parallel to the axis of the hose, wrap the Hose Tag tightly around the hose, then continue to wrap the clear plastic panel over the Hose Tag.
6. Press firmly to ensure that the adhesive bonds.

GRAM HOSE TAGS SPECIFICATIONS				
PART NO	SUITS HOSE SIZE ID RANGE			SIZE
	DN	INCH	DASH	
<b>GRAM-S</b> (Small)	6 to 31	1/4 to 1.1/4"	-04 to -20	50mm x 174.5mm
<b>GRAM-L</b> (Large)	12 to 51	3/4 to 2"	-12 to -32	50mm x 279.5mm

Contact RYCO for further information.



**000PN1806280001**

RYCO HYDRAULICS PTY LTD  
28 JUN 2018  
GRAM PUMP  
HAT5008D000123  
H123-01  
RYCO HYDRAULICS PTY LTD

INTRODUCTION

HOSE

COUPLINGS

ADAPTORS

TECHNICAL

# HOSE

## HOSE TRACKING – RHYT HOSE TAG

### RHYT/ RHWT HOSE TAG



#### RECOMMENDED FOR:

Permanent identification of hose assemblies. RYCO Hose Tags enable hose assembly information to be attached to the hose assembly in a cost effective manner.

Two sizes of Hose Tags allow all common hose sizes to be tagged.

Information can be written or printed on the Hose Tag prior to being attached to the hose. When the Hose Tag is wrapped on the hose, a clear panel at the end of the tag wraps over to protect the written or printed information.

Hose Tag remains in position on the hose due to the adhesive backing, and the Hose Tag bends with the hose, ensuring that flexibility is not affected.

The slim profile of the attached Hose Tag reduces the risk of accidental removal. Hose Tag does not damage or cut the cover of the hose.

#### CONSTRUCTION:

Heat, oil, ozone, sunlight, and weather resistant high performance plastic.

Adhesive-backed for permanent attachment to the hose assembly. Area to write or print information, with a clear panel that wraps over to protect the hose assembly identification information.

#### TEMPERATURE RANGE:

Suitable for use with all RYCO Hoses at their published temperature ranges.

#### ASSEMBLY INSTRUCTIONS:

1. Select correct size of RYCO RHYT Hose Tag for the hose assembly that is to be identified.
2. Two sizes are available:
3. **RHYT-10** and **RHWT-10** suits hose sizes -04 to -10 (1/4" to 5/8").
4. **RHYT-32** and **RHWT-32** suits hose sizes -12 to -32 (3/4" to 2").
5. Using a ball point pen or label printer, apply the required information onto the Hose Tag.
6. Remove the release paper from the back of the Hose Tag to expose the adhesive.
7. While ensuring that the Hose Tag is parallel to the axis of the hose, wrap the Hose Tag tightly around the hose, then continue to wrap the clear plastic panel over the Hose Tag.
8. Press firmly to ensure that the adhesive bonds.

### RHYT HOSE TAGS SPECIFICATIONS

RHYT/RHWT HOSE TAGS			
PART NO	SUITS HOSE SIZE ID RANGE		
	DN	INCH	DASH
<b>RHYT-10</b>	6 to 16	1/4 to 5/8	-04 to -10
<b>RHYT-32</b>	12 to 51	3/4 to 2	-12 to -32
<b>RHWT-10</b>	6 to 16	1/4 to 5/8	-04 to -10
<b>RHWT-32</b>	12 to 51	3/4 to 2	-12 to -32

Contact RYCO for further information.

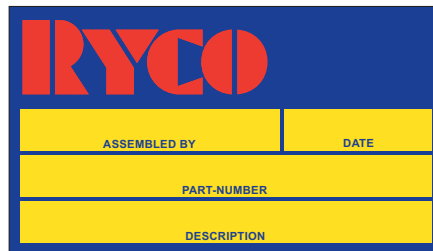

**RHYT-32**

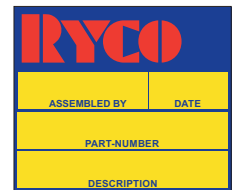

**RHYT-10**

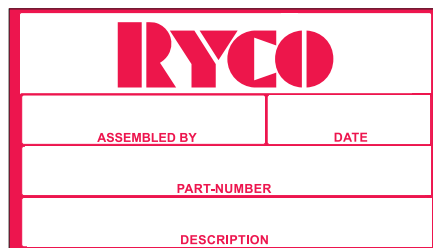

**RHWT-32**

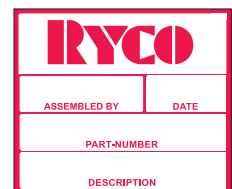

**RHWT-10**

## HOW TO ORDER RYCO HYDRAULIC HOSE

### SEE PAGES 465 AND 466 FOR "HOW TO ORDER HOSE ASSEMBLIES".

Coil length of RYCO Hydraulic Hose varies according to Hose Series and Size.

Wire braid, textile braid and spiral wire reinforced hydraulic hoses are in most cases manufactured in long lengths on flexible mandrels, which results in coils of hose of different lengths. These hoses are produced and supplied in random lengths.

SRF and SRX Suction Hoses are manufactured on rigid mandrels of a specified length.

SRF and SRX Hose 20 metres (65.6 ft)

If hose is part of a general stock order, every effort will be made to supply length closest to length ordered, but length supplied may be shorter or longer than length ordered. If ordering "a coil" of hose, please specify the length required. If a specific cut length is required, this must be specified when ordering, e.g. 19,5 metres exact length and may be subject to surcharge.

Shown in the table below is the availability of RYCO Hydraulic Hose in Coils (C), and on Reels (R) or in Bulk Cartons (B).

Details of average quantities packed on reels (or in cartons) and their dimensions are available from RYCO on request.

HOSE SIZE		HOSE SERIES																																		
DASH	INCH	T3000D/S	T3600C	T4000D/S	T5000D/S	T6000D/S	H3000D/S	H4000D/S	H5000C	H5000D/S	H6000D/S	C6000D	C6000S	DF1D	DF2D	DK1D/E/S	DK2D/E/S	EC1/2	ECP1	E1	E2	T1D/S	T1F	T2D/S	T2C	TXA2D	H12D/S	R4SPD	R4SHD	TJ2D	RQP1	RQP2	RQP5	RQP6		
-03	3/16"																						R	R,C												
-04	1/4"	R,C	R,C	R,C	R,C	R,C								R,C	R,C	R,C	R,C	R,C		R,C	R,C	R,C	R,C	R,C	R,C							R,C	R,C	R,C	R,C	R,C
-05	5/16"	R,C	R,C	R,C	R,C	R,C								R,C	R,C	R,C	R,C	R,C		R,C	R,C	R,C	R,C	R,C	R,C						R,C	R,C	R,C	R,C	R,C	
-06	3/8"	R,C	R,C	R,C	R,C	R,C		R,C		R,C	R,C			R,C	R,C	R,C	R,C	R,C		R,C	R,C	R,C	R,C	R,C	R,C		R,C	R,C	R,C		R,C	R,C	R,C	R,C	R,C	
-08	1/2"	R,C	R,C	R,C	R,C			R,C		R,C	R,C	R,C	R,C	R,C	R,C	R,C	R,C	R,C		R,C	R,C	R,C	R,C	R,C	R,C	R,C	R,C	R,C	R,C		R,C	R,C	R,C	R,C	R,C	
-10	5/8"	R,C	R,C	R,C				R,C,B		R,C,B	R,C			R,C	R,C	R,C	R,C	R,C		R,C	R,C	R,C	R,C	R,C	R,C	R,C	R,C	R,C	R,C		R,C	R,C	R,C	R,C	R,C	
-12	3/4"	R,C	R,C	R,C				R,C,B	R,C	R,C,B	R,C	R,C	R,C	R,C	R,C	R,C	R,C	R,C		R,C	R,C	R,C	R,C	R,C	R,C	R,C	R,C	R,C	R,C		R,C	R,C	R,C	R,C	R,C	
-16	1"	R,C	R,C					R,C,B	R,C	R,C,B	R,C	R,C	R,C	R,C	R,C	R,C	R,C	R,C		R,C	R,C	R,C	R,C	R,C	R,C	R,C	R,C	R,C	R,C		R,C	R,C	R,C	R,C	R,C	
-20	1.1/4"						B	B	B	B	B											B	B	B	B	B	B	B				B	B			
-24	1.1/2"						B	B		B	B											B	B	B	B	B	B	B				B	B			
-32	2"						B	B		B	B											B	B	B	B	B	B	B				B	B			
-40	2.1/2"																							B			B									
-48	3"																							B												

HOSE SIZE		HOSE SERIES																								
DASH	INCH	D2B	T5	MS1000	CS1000	BT1	SW	JS4000/G/GX/BX	JS6000/G/GX/BX	SRF	SRX	RTH1	PL1/PL1D	M1	MP1	M2	M2G	TP7	TP7N	TP7T/TN	TP8	TP8N	TP8T	TP8TN	TP3000	
-03	3/16"												R,C								R,B					
-04	1/4"		R,C			R,C			R,C			R,C	R,C	R,C	R,C	R,C	R,C	R,C	R,C	R,C	R,C	R,C	R,C	R,C	R,C	R,C
-05	5/16"		R,C			R,C		R,C	R,C			R,C	R,C	R,C		R,C		R,C		R,C						
-06	3/8"		R,C			R,C	R,C	R,C,B	R,C			R,C	R,C	R,C	R,C	R,C	R,C	R,C	R,C	R,C	R,C	R,C	R,C	R,C	R,C	R,C
-08	1/2"		R,C	R,C	R,C	R,C	R,C	R,C	R,C			R,C	R,C		R,C	R,C	R,C	R,C	R,C	R,C	R,C	R,C	R,C	R,C	R,C	R,C
-10	5/8"		R,C	R,C	R,C	R,C		R,C				R,C	R,C		R,C											
-12	3/4"		R,C	R,C	R,C	R,C	R,C	R,C				R,C	R,C		R,C	R,C	R,C	R,C	R,C							
-16	1"		R,C	R,C	R,C	R,C	R,C	R,C				R,C	R,C		R,C	R,C			R,C	R,C						
-20	1.1/4"	B	B	B	B										B											
-24	1.1/2"	B	B	B	B																					
-32	2"	B	B	B	B																					
-40	2.1/2"													C												
-48	3"																									

INTRODUCTION

HOSE

COUPLINGS

ADAPTORS

TECHNICAL

# ■ COUPLINGS





**THIS SECTION IS ARRANGED IN THE FOLLOWING COUPLING SERIES ORDER:**

PAGES	COUPLING SERIES	APPLICATION
<b>ONE-PIECE CRIMP COUPLINGS</b>		
187 to 232	<b>T2000</b>	One-Piece Crimp for Wire Braid Hose T3000D, T3000S, T3600D, T3600S, T4000D, T4000S, T5000D, T5000S, T6000D, T6000S, DF1D, DF2D, DK1D, DK1E, DK1S, DK2D, DK2E, DK2S, EC1, EC2, E1, E2, T1D, T1F, T1S, T2D, T2S, T2C, TXA2D, RQP1, RQP2, TW1, PW2, BT1, TJ2D, CS1000, JS4000, JS6000 and MS1000.
233 to 249	<b>T4000</b>	One-Piece Crimp for M2, M2G, MP1, RQP5, BT1, TP7, TP7N, TP7T, TP7TN, TP3000, PL1, PL1D, PL1PV, RQP6, MS1000, CS1000, SRX, SRF and T5 hose.
250 to 271	<b>T6000</b>	One-Piece Crimp for Wire Braid Hose and selected High Pressure Spiral Hose H5000D, H5000S, H6000D, H6000S.
272 to 302	<b>T7000</b>	One-Piece Crimp for Wire Braid Hose and selected High Pressure Spiral Hose H3000D, H3000S, H4000D, H4000S, H5000C, H5000D, H6000D, H6000S, C6000D, H6000S, E2, T2S, TXA2D, H12D, H12S, R4SPD, R4SHD, RQP2, D2B.
303 to 316	<b>TP000</b>	For RYCO Hose Series TP7, TP7N, TP7T, TP7TN, TP8, TP8N, TP8T, TP8TN, TP3000 all sizes
317 to 320	<b>TT000</b>	One-Piece Crimp for RTH1 Hose
321 to 322	<b>TG000</b>	One-Piece Crimp for TPGL Greaseline

<b>FIELD ATTACHABLE COUPLINGS</b>		
325 to 331	<b>8000</b>	Push-On for PL1, PL1D, PL1PV and RQP6 Hose
332 to 338	<b>33000</b>	Suction and Return for SRX and SRF Hose
339 to 352	<b>V000</b>	Field Attachable for RQP5 and T5 Hose
353 to 354	<b>K000, L000, M000, P000</b>	Field Attachable Ferrules
355 to 385	<b>6000</b>	Field Attachable Inserts for Wire Braid Hose, M2 and M2G Series Textile Braid Hose, and TPGL Hose With appropriate Ferrules, these form K000, L000, M000, P000 and V000 Series Field Attachable Couplings

<b>TWO INDEXES FOLLOW:</b>		
172 to 180	—	Pictorial Index
181 to 185	—	Index by End Style Number & Coupling Series

<b>WITHIN EACH COUPLING SERIES THE LISTING ORDER IS ALPHABETICAL* BY THREAD OR CONNECTOR TYPE:</b>
BSP (BSPT, BSPP, BSPO, BSPP ENCAPSULATED SEAL, BSPP O RING, BANJO)
NPT* (NPT, NPTF, NPSM)
GREASELINE
JSEAL™ / JIC
JIS (BSP, METRIC)
JOINER
METRIC (DKL, DKOL, DKS, DKOS, JIS, BANJO)
ORFS
PW
RYCOLOK, SUPERLOK
RYCO WEO
SAE (Thread, then Flange)
SALVAGE
STANDPIPE
TUBE BITE
UNO (O RING BOSS)
Hammer Union (wing union)

\*NOTE: NPT is not in strict alphabetical order. NPT is similar in concept to BSP therefore has been placed directly after BSP.

<b>WITHIN EACH ALPHABETICAL THREAD OR CONNECTOR TYPE, THE LISTING ORDER IS:</b>
MALE
FEMALE
SPECIAL FEATURES (live swivel, etc)
SPECIAL SEATS (flat, concave, etc)
ELBOWS (45° then 90°)
TUBE BENDS (in increasing degree of bend from 10° to 110°)

INTRODUCTION

HOSE

COUPLINGS

ADAPTORS

TECHNICAL

# COUPLINGS

## INFORMATION

RYCO Hydraulics manufacture hose couplings in many different styles and sizes to match each RYCO hose series, with a wide range of thread and connection types.

Hose Couplings must be carefully matched to the hose. When the hose for an application has been selected, it is crucial that the couplings to be fitted are designed specifically for that hose. This information is listed in this RYCO PRODUCT TECHNICAL MANUAL on the pages for each Hose Series, and also on the pages for each Coupling Series.

### HOSE COUPLINGS CAN BE BROADLY DIVIDED INTO TWO TYPES:

#### 1) FIELD ATTACHABLE COUPLINGS

Attached to the hose using commonly available hand tools. Push-On Hose Couplings and Suction and Return Hose Couplings are often classed as Field Attachable couplings.

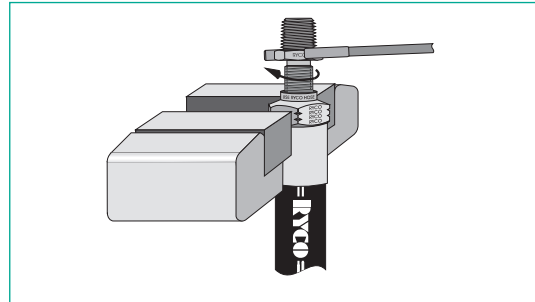

#### 2) CRIMP, OR SWAGE, COUPLINGS

Permanently attached to the hose using a crimping, or swaging, machine.

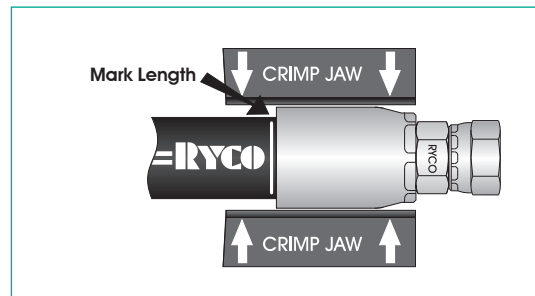

### DO NOT MIX / MATCH HOSE AND COUPLINGS FROM DIFFERENT MANUFACTURERS.

It is critical that the hose and coupling manufacturer are the same and that they are assembled using the manufacturer's recommended equipment, components and procedures.

Female Swivel Nut fittings are typically illustrated as "Crimp Nut", except T7020H.

Generally, RYCO Fittings are as follows:

1. BSPP, NPSM, JIC, JIS, ORFS and SAE nuts are "Crimp Nut" up to and including 1" Hose Size; and "Wire Nut" 1.1/4" to 2" Hose Size.
2. PW and SAE Inverted Flare Male nuts are always "Slip Nut."
3. JSEAL™, Metric DKL, DKOL, DKS and DKOS nuts are generally "Slip Nut" where possible and "Wire/Crimp Nut" on jump sizes.
4. T7022 is "Wire Nut".

There are many exceptions to these general rules; for precise information, contact RYCO.

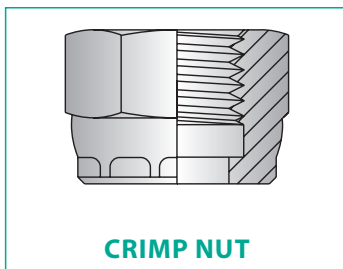

CRIMP NUT

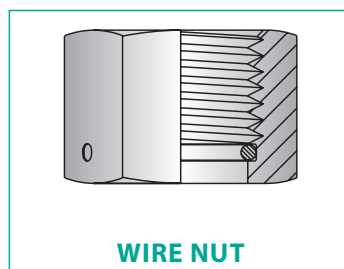

WIRE NUT

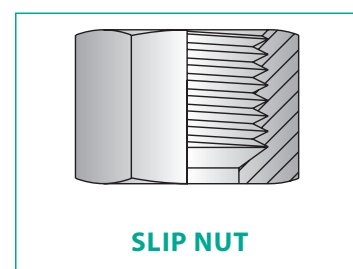

SLIP NUT

### ONE-PIECE CRIMP COUPLINGS

RYCO Crimp Couplings are permanently attached fittings, assembled onto the hose with a swaging press.

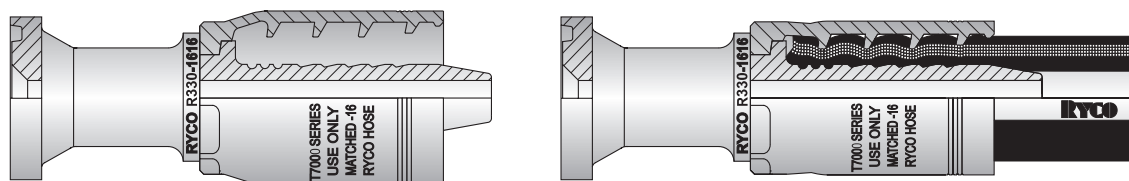

RYCO One-Piece Crimp Couplings have the ferrule already attached to the hose insert at the factory. This eliminates the possibility of selecting the wrong ferrule type when fabricating hose assemblies, which can cause failure of the assembly.

Each One-Piece Crimp Coupling Series suits specific styles of hose, as shown in the table below. T2000, T4000, T6000, T7000, TP000 and TT000 One-Piece Crimp Couplings Series can be used on more than one hose style - only the finished crimp diameter changes.

One-Piece Crimp couplings eliminate the need to "skive" the cover off the hose before attaching the couplings - even for Spiral reinforced hoses. This makes assembly simple, quick and efficient. Simply push the coupling onto the hose to the correct mark length, and crimp the ferrule. The teeth inside the ferrule BITE down though the cover to LOK onto the reinforcement wires\*.

\* T4000 Series for One and Two Braid Textile reinforced hoses do not bite down to the textile reinforcement.

### RYCO T2000, T4000, T6000, T7000 SERIES COUPLINGS

Branding of T2000, T4000, T6000 and T7000 Couplings shows a universal prefix "R".

T2000 has two grooves, T4000 has three grooves and T6000 has six grooves (three at the top and three at the bottom of the ferrule) branded on the ferrule (body) of the Couplings signifying their series designation, T7000 has four grooves.

#### T2000 EXAMPLE

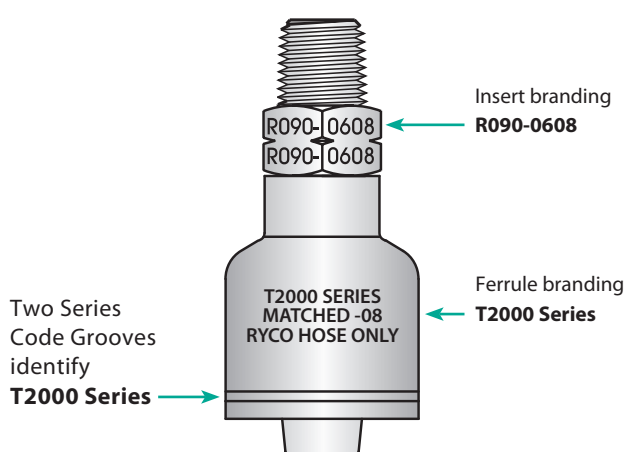

To complete the Part Number for Coupling:  
Insert Part Branding is **R090-0608**

Series is **T2000** (from **T2000** Ferrule Branding or Two Series Code Grooves)

Simply replace "R" of Insert Part Branding with "T2" (first two characters of Series): **T2090-0608**

#### T4000 EXAMPLE

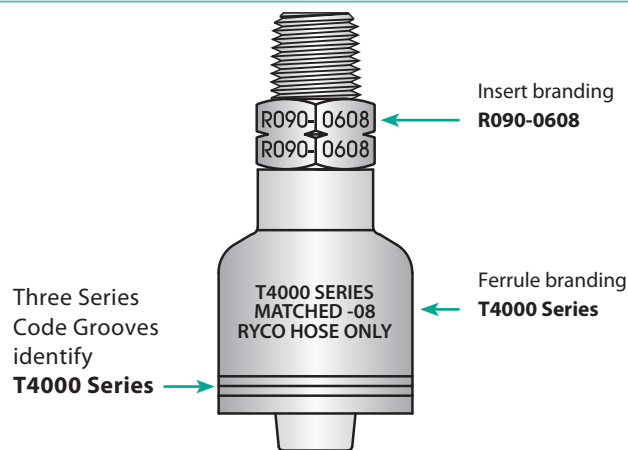

To complete the Part Number for Coupling:  
Insert Part Branding is **R090-0608**

Series is **T4000** (from **T4000** Ferrule Branding or Three Series Code Grooves)

Simply replace "R" of Insert Part Branding with "T4" (first two characters of Series): **T4090-0608**

# COUPLINGS

## INFORMATION

### RYCO T2000, T4000, T6000 AND T7000 SERIES COUPLINGS (CONT)

#### T6000 EXAMPLE

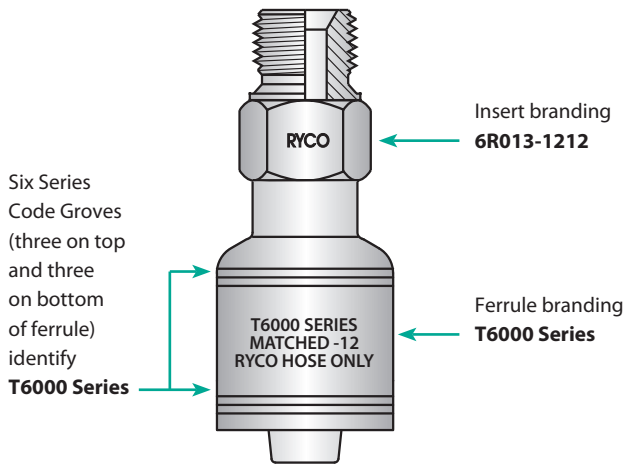

To complete the Part Number for Coupling:  
Insert Part Branding is **6R013-1212**

Series is **T6000** (from Six Series Code Groove, three at each end)

Simply replace "R" of Insert Part Branding with "T6"  
(first two characters of Series): **T6013-1212**

#### T7000 EXAMPLE

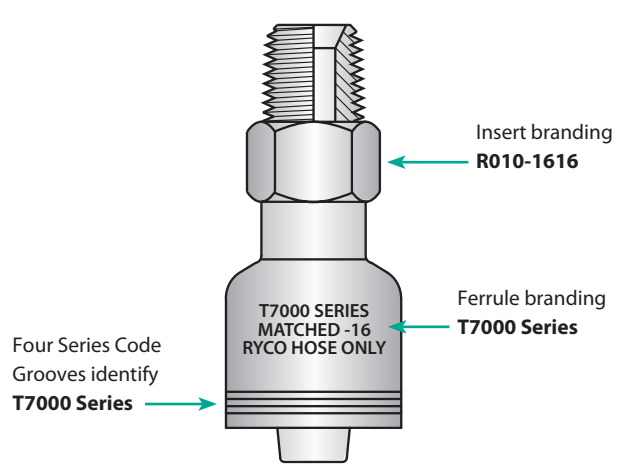

To complete the Part Number for Coupling:  
Insert Part Branding is **R010-1616**

Series is **T7000** (from **T7000** Ferrule Branding or Four Series Code Grooves)

Simply replace "R" of Insert Part Branding with "T7"  
(first two characters of Series): **T7010-1616**

### RYCO TP000, TT000 SERIES COUPLINGS

Branding of TP000 and TT000 Couplings shows a universal prefix "R".

TP000 has two knurls, TT000 has four grooves branded on the ferrule (body) of the Couplings signifying their series designation.

#### TP000 EXAMPLE

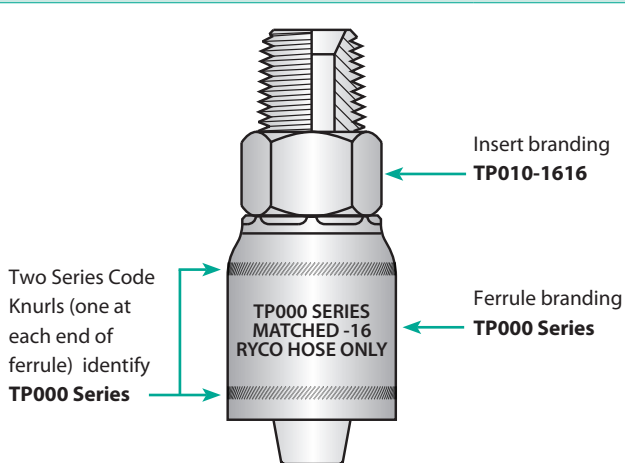

To complete the Part Number for Coupling:  
Insert Part Branding is **TP010-1616**

Series is **TP000** (from **TP000** Ferrule Branding or Two Series Code Knurls)

Simply replace "R" of Insert Part Branding with "TP"  
(first two characters of Series): **TP010-1616**

#### TT000 EXAMPLE

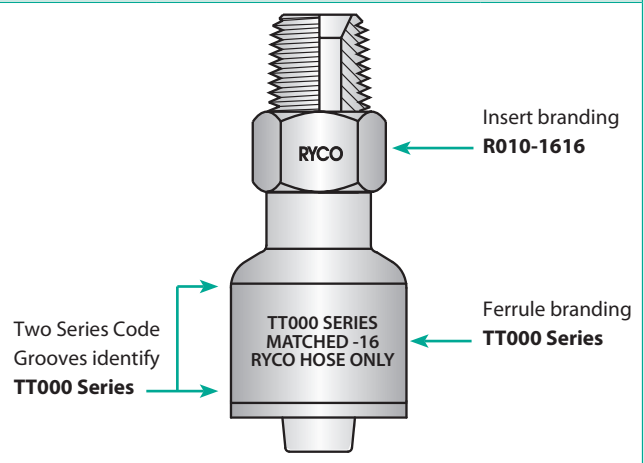

To complete the Part Number for Coupling:  
Insert Part Branding is **R010-1616**

Series is **TT000** (from **TT000** Ferrule Branding or Four Series Code Grooves)

Simply replace "R" of Insert Part Branding with "TT"  
(first two characters of Series): **TT010-1616**

SERIES	SUITS HOSE TYPE	RYCO HOSE SERIES AND SIZES
<b>T2000</b> Pages 187 to 232	<b>One and two wire braided hoses.</b> <b>TWO SERIES CODE GROOVES</b> (at end of ferrule).	For RYCO Hose Series, T3000D/S, T3600D/S (sizes -04 to -16). For RYCO Hose Series T4000D/S (sizes -04 to -12). For RYCO Hose Series T5000D/S (sizes -04 to -08). For RYCO Hose Series T6000D/S (sizes -04 to -06). For RYCO Hose Series T1D/S (sizes -03 to -32). For RYCO Hose Series RQP1 (sizes -04 to -16). For RYCO Hose Series E1 (sizes -03 to -32). For RYCO Hose Series T3 (sizes -04 to -16). For RYCO Hose Series T2D/S (sizes -04 to -48). For RYCO Hose Series TJD (sizes -24 to -26). For RYCO Hose Series T2C (sizes -04 to -32). For RYCO Hose Series E2/C (sizes -03 to -16). For RYCO Hose Series DF2D (sizes -04 to -20). For RYCO Hose Series D2B (sizes -24 to -32). For RYCO Hose Series JS4000/B/G/BX/GX (sizes -04 to -08). For RYCO Hose Series JS6000/B/G/BX/GX (sizes -04 to -08). For RYCO Hose Series TW (sizes -04 to -08). For RYCO Hose Series PW (sizes -04 to -06). For RYCO Hose Series BT1 (sizes -04 to -16). For RYCO Hose Series MS1000 (sizes -08 to -32).
<b>T4000</b> Pages 233 to 249	<b>Some one and two textile braided hoses and some speciality hoses.</b> <b>THREE SERIES CODE GROOVES</b> (at end of ferrule).	For RYCO Hose Series SRF, SRX (sizes -12 to -48). For RYCO Hose Series RT7/T/7N/7TN (sizes -02 to -12). For RYCO Hose Series T5, RQP5 (sizes -04 to -32). For RYCO Hose Series MP1 (sizes -04 to -20). For RYCO Hose Series RST (sizes -08 to -48). For RYCO Hose Series PCM (sizes -08 to -16). For RYCO Hose Series M2/G, PL1, PL1D, PL1PV (sizes -04 to -12).
<b>T6000</b> Pages 250 to 271	<b>Selected spiral hoses.</b> <b>TWO SETS OF THREE SERIES CODE GROOVES</b> (one at each end of ferrule).	For RYCO Hose Series H5000 (sizes -24 to -32). For RYCO Hose Series H6000 (sizes -12 to -32).
<b>T7000</b> Pages 272 to 302	<b>Selected spiral hoses and some one and two wire braided hoses.</b> <b>FOUR SERIES CODE GROOVES</b> (at end of ferrule).	For RYCO Hose Series H3000D/S (sizes -20 to -32). For RYCO Hose Series H4000D/S (sizes -06 to -32). For RYCO Hose Series H5000D/S (sizes -06 to -24). For RYCO Hose Series H6000D/S (sizes -06 to -20). For RYCO Hose Series T2D/S/C (sizes -06 to -32). For RYCO Hose Series E2, HSPD (sizes -06 to -16). For RYCO Hose Series H12D/S (sizes -06 to -20). For RYCO Hose Series R4SH, HSHD (sizes -20 to -32). For RYCO Hose Series T2, TXA2D, RQP2 (sizes -06 to -32). For RYCO Hose Series D2B (sizes -24 to -32). For RYCO Hose Series R4SP (cover must be skived) (all sizes).
<b>TP000</b> Pages 303 to 316	<b>Thermoplastic hoses.</b> <b>TWO SERIES CODE KNURLS</b> (one at each end of ferrule).	For RYCO Hose Series TP7, TP7N, TP7T, TP7TN, TP8, TP8N, TP8T, TP8TN, TP3000 (all sizes).
<b>TT000</b> Pages 317 to 320	<b>TEFLON® hoses.</b> <b>TWO SERIES CODE GROOVES</b> (one at each end of ferrule).	For RYCO Hose Series RTH1 (all sizes).
<b>TG000</b> Pages 321 to 322	<b>Greasing and lubrication hoses.</b> <b>ONE SERIES CODE KNURL</b> (at end of ferrule).	For RYCO Thermoplastic grease line hoses - TPGL (all sizes).
<b>TW4000</b> Page 323	<b>SHOCKWAVE hoses.</b> <b>FOUR SERIES CODE GROOVES</b> (at end of ferrule).	For RYCO Hose Series SHOCKWAVE (all sizes).

INTRODUCTION

HOSE

COUPLINGS

ADAPTORS

TECHNICAL



# COUPLINGS

## PICTORIAL INDEX

### MALE STRAIGHT

<b>T2010/11</b> P187	<b>T2013</b> P188	<b>T2017</b> P189	<b>T2220</b> P190	<b>T2320</b> P191	<b>T2475</b> P193	<b>T2090</b> P197	<b>T2091</b> P197
<b>T4010</b> P233	<b>T4013</b> P233			<b>T4320</b> P233		<b>T4090</b> P236	
<b>T6010</b> P250	<b>T6013</b> P250					<b>T6090</b> P252	<b>T6091</b> P252
<b>T7010</b> P272	<b>T7014</b> P272	<b>T7013</b> P273				<b>T7090</b> P277	<b>T7091</b> P277
<b>TP010</b> P303					<b>TP475</b> P305	<b>TP090</b> P306	
<b>TT010</b> P317				<b>TT320</b> P317		<b>TT090</b> P320	



BSPT MALE	BSPT MALE HEAVY	BSPM MALE	BSPM MALE CAPTIVE SEAL	BSPM MALE 60° CONVEX SEAT (UIS)	BSPT MALE SWIVEL	BSP BANJO	NPT MALE	NPT MALE EXTENDED
-----------	-----------------	-----------	------------------------	---------------------------------	------------------	-----------	----------	-------------------

### MALE STRAIGHT cont'd

<b>T2320N</b> P198	<b>T2030/31</b> P200	<b>T2650</b> P208	<b>T2630</b> P213	<b>T2470</b> P217	<b>T2840</b> P218	<b>T2950</b> P221	<b>T2480</b> P223	<b>T2870</b> P222
<b>T4320N</b> P236	<b>T4030/31</b> P237				<b>T4840</b> P243		<b>T4870</b> P247	
	<b>T6030/31</b> P252		<b>T6630</b> P255		<b>T6840</b> P256		<b>T6480</b> P289	<b>T6870</b> P288
	<b>T7030/31</b> P278		<b>T7630</b> P284		<b>T7840</b> P286		<b>T7480</b> P289	<b>T7870</b> P288
	<b>TP030/31</b> P307	<b>TP650</b> P310	<b>TP630</b> P312	<b>TP470</b> P313				
	<b>TT030/31</b> P318							



NPT MALE SWIVEL	JIC MALE	METRIC DKL MALE 24° CONE	METRIC DKS MALE 24° CONE	METRIC BANJO	ORFS MALE	PW GUN HANDLE TUBE	RYCO WEO MALE	RYCOLOK MALE
-----------------	----------	--------------------------	--------------------------	--------------	-----------	--------------------	---------------	--------------

### MALE STRAIGHT cont'd

<b>T2530</b> P224	<b>T2740</b> P225	<b>T2200</b> P231	<b>T2380</b> P231		<b>T2482</b> P223	<b>T2871</b> P222	<b>T2750</b> P226
<b>T4530</b> P245	<b>T4740</b> P246	<b>T4200</b> P249					<b>T4750</b> P246
<b>T6876</b> P257						<b>T6871</b> P257	
<b>T7876</b> P288		<b>T7200</b> P302			<b>T7482</b> P289	<b>T7871</b> P288	



SUPERLOK MALE	SAE MALE	SAE INVERTED MALE FLARE	UN O RING MALE (O RING BOSS)	UN O RING MALE SWIVEL (O RING BOSS)	RYCO WEO MALE 45° TUBE BEND	RYCOLOK MALE 45° ELBOW	SAE INVERTED MALE FLARE 45° TUBE BEND
---------------	----------	-------------------------	------------------------------	-------------------------------------	-----------------------------	------------------------	---------------------------------------

### MALE 45°

### MALE 45°, 60° & 90°

<b>T2760</b> P226	<b>T2340</b> P191	<b>T2340N</b> P198	<b>T2483</b> P223	<b>T2872</b> P222	<b>T2780</b> P226	<b>T2790</b> P226	<b>T2770</b> P226	<b>T2390</b> P232
	<b>T4340</b> P234						<b>T4770</b> P246	
				<b>T6872</b> P257				
			<b>T7483</b> P289	<b>T7872</b> P288				
	<b>TP340N</b> P306							



SAE INVERTED MALE FLARE 60° TUBE BEND	BSPT MALE SWIVEL 90° ELBOW	NPT MALE SWIVEL 90° ELBOW	RYCO WEO MALE 90° TUBE BEND	RYCOLOK MALE 90° ELBOW	SAE INVERTED MALE FLARE 90° ELBOW	SAE INVERTED MALE FLARE 90° EXTENDED ELBOW	SAE INVERTED MALE FLARE 90° TUBE BEND	UN O RING MALE SWIVEL (O RING BOSS) 90° ELBOW
---------------------------------------	----------------------------	---------------------------	-----------------------------	------------------------	-----------------------------------	--	---------------------------------------	---

INTRODUCTION  
HOSE  
COUPLINGS  
ADAPTORS  
TECHNICAL

FEMALE STRAIGHT

<b>T2020</b> P205	<b>T2028B</b> P192	<b>T2024</b> P192	<b>T2122</b> P205	<b>T2027</b> P195	<b>T2190</b> P199	<b>T2020N</b> P199	<b>T2861</b> P200
<b>T4020</b> P234				<b>T4122</b> P241		<b>T4020N</b> P236	
<b>T6020</b> P251		<b>T6022</b> P251				<b>T6020N</b> P252	
<b>T7020</b> P273		<b>T7022</b> P273		<b>T7122</b> P282		<b>T7027</b> P275	
<b>TP020</b> P304				<b>TP122</b> P304		<b>TP020N</b> P307	
<b>TT020</b> P317							



BSPP FEMALE	BSPP FEMALE LIVE SWIVEL	BSPP FEMALE HEAVY	BSPP FEMALE FLAT FACE	BSPP FEMALE 60° CONCAVE SEAT (JIS)	BSPO FEMALE	NPT FEMALE FIXED	NPSM FEMALE	GREASE LINE FIXED FEMALE
-------------	-------------------------	-------------------	-----------------------	------------------------------------	-------------	------------------	-------------	--------------------------

FEMALE STRAIGHT cont'd

<b>T2040/41</b> P201	<b>T2600</b> P210	<b>T2610</b> P210	<b>T2501</b> P211	<b>T2711</b> P214	<b>T2680</b> P206	<b>T2800/01</b> P219	<b>T2540</b> P225
<b>T4040/41</b> P238		<b>T4600</b> P241		<b>T4501</b> P242		<b>T4800/01</b> P243	
<b>T6040</b> P253		<b>T6045</b> P253		<b>T6711</b> P255		<b>T6800/01</b> P256	
<b>T7040/41</b> P279		<b>T7045</b> P279		<b>T7501</b> P283		<b>T7711</b> P285	
<b>TP040/41</b> P308		<b>TP600</b>		<b>TP501</b> P311		<b>TP711</b> P312	
<b>TT040/41</b> P319				<b>TT600</b> P320			



JSEAL™ / JIC FEMALE	JIC FEMALE HIGH PRESSURE	METRIC DKL FEMALE 24°/60° CONE	METRIC DKM FEMALE 60° BALL SEAT	METRIC DKOL FEMALE 24° CONE	METRIC DKOS FEMALE 24° CONE	METRIC FEMALE 60° CONCAVE SEAT (JIS)	ORFS FEMALE	SAE FEMALE
---------------------	--------------------------	--------------------------------	---------------------------------	-----------------------------	-----------------------------	--------------------------------------	-------------	------------

FEMALE STRAIGHT cont'd & FEMALE 45°

<b>T2940</b> P221	<b>T2060</b> P193	<b>T2080/81</b> P202	<b>T2580</b> P225	<b>T2270</b> P194	<b>T2277</b> P196	<b>T2250/51</b> P203	<b>T2682</b> P206	<b>T2660</b> P209
						<b>T4250/51</b> P239		<b>T4660</b> P241
<b>T6080</b>				<b>T6270</b> P251		<b>T6250</b> P253		
<b>T7060</b> P274		<b>T7080</b> P280		<b>T7270</b> P274		<b>T7277</b> P276		<b>T7250/51</b> P280
<b>TP270</b> P305						<b>TP250/51</b> P280		











PRESSURE WASHER FEMALE	BSPP FEMALE 45° ELBOW	JSEAL™ / JIC FEMALE 45° ELBOW	SAE FEMALE 45° ELBOW	BSPP FEMALE 45° TUBE BEND	BSPO FEMALE 45° TUBE BEND	JSEAL™ / JIC FEMALE 45° TUBE BEND	METRIC JIS FEMALE 60° CONCAVE SEAT 45° TUBE BEND	METRIC DKL FEMALE 24°/60° CONE 45° TUBE BEND
------------------------	-----------------------	-------------------------------	----------------------	---------------------------	---------------------------	-----------------------------------	--	--









# COUPLINGS

## PICTORIAL INDEX







FEMALE  
45°  
cont'd  
&  
FEMALE  
90°

<b>T2510</b> P211	<b>T2720</b> P215	<b>T2810/11</b> P220		<b>T2050</b> P196	<b>T2057</b> P196	<b>T2070/71</b> P167	<b>T2570</b> P225	<b>T2260</b> P194
		<b>T4810/11</b> P244	<b>T4550</b> P245	<b>T4050</b> P234			<b>T4570</b> P245	<b>T4260</b> P234
	<b>T6720</b> P255	<b>T6810/11</b> P181				<b>T6070</b>		<b>T6260</b> P251
<b>T7510</b> P283	<b>T7720</b> P285	<b>T7810/11</b> P287		<b>T7050</b> P274	<b>T7057</b> P275	<b>T7070</b> P280		<b>T7260</b> P274
<b>TP510</b> P311	<b>TP720</b> P313	<b>TP810/11</b> P315		<b>TP050</b> P304			<b>TP570</b> P316	<b>TP260</b> P304
<b>TT050</b> P318								<b>TT260</b> P318
								
METRIC DKOL FEMALE 24° CONE 45° TUBE BEND	METRIC DKOS FEMALE 24° CONE 45° TUBE BEND	ORFS FEMALE 45° TUBE BEND	SAE FEMALE 45° TUBE BEND	BSPP FEMALE 90° ELBOW	BSPO FEMALE 90° ELBOW	JSEAL™ / JIC FEMALE 90° ELBOW	SAE FEMALE 90° ELBOW	BSPP FEMALE 90° TUBE BEND

FEMALE  
90°  
cont'd







<b>T2210</b> P195	<b>T2267</b> P196	<b>T2243/44</b> P203	<b>T2240/41</b> P204		<b>T2280/81</b> P204	<b>T2683</b> P206	<b>T2670</b> P210	<b>T2520</b> P212
		<b>T4243</b> P240	<b>T4240/41</b> P240		<b>T4280/81</b> P240		<b>T4670</b> P242	
			<b>T6240</b> P254		<b>T6280</b> P254			
<b>T7210</b> P275	<b>T7267</b> P276	<b>T7243</b> P281	<b>T7240/41</b> P281	<b>T7245</b> P281	<b>T7280</b> P282			<b>T7520</b>
			<b>TP240/41</b> P309		<b>TP280</b> P310			<b>TP520</b> P311
<b>TT240/41</b> P319							<b>TT670</b> P320	
								
BSPP FEMALE 90° LONG BEND	BSPO FEMALE 90° TUBE BEND	JSEAL™ / JIC FEMALE 90° SHORT BEND	JSEAL™ / JIC FEMALE 90° MEDIUM BEND	JIC FEMALE HIGH PRESSURE 90° MEDIUM BEND	JSEAL™ / JIC FEMALE 90° LONG BEND	METRIC FEMALE 90° CONCAVE SEAT (JIS) 90° TUBE BEND	METRIC DKL FEMALE 24°/60° CONE 90° TUBE BEND	METRIC DKOL FEMALE 24° CONE 90° TUBE BEND

FEMALE  
90°  
cont'd

<b>T2730</b> P216	<b>T2823/24</b> P220	<b>T2820/21</b> P221	<b>T2830</b> P221		<b>T2900</b> P207
		<b>T4820/21</b> P244	<b>T4830</b> P244	<b>T4560</b> P246	
	<b>T6730</b> P255	<b>T6820/21</b> P257			<b>T6900</b> P254
<b>T7730</b> P285	<b>T7823/24</b> P287	<b>T7820/21</b> P287	<b>T7830</b> P287		<b>T7900</b> P283
<b>TP730</b> P285	<b>TP820/21</b> P287				
					
METRIC DKOS FEMALE 24° CONE 90° TUBE BEND	ORFS FEMALE 90° SHORT BEND	ORFS FEMALE 90° MEDIUM BEND	ORFS FEMALE 90° LONG BEND	SAE FEMALE 90° TUBE BEND	JOINER

JOINER

SALVAGE  
STANDPIPE

<b>T2230</b> P228	<b>T2180</b> P229	<b>T2640</b> P229	<b>T2646</b> P230		<b>T2850</b> P231
<b>T4230</b> P247					<b>T4850</b> P249
<b>T7230</b> P301		<b>T7640</b> P300	<b>T7643</b>		
<b>TP230</b>	<b>TP640</b> P314	<b>TP643</b> P314	<b>TP646</b> P314		
					
SALVAGE (LIFESAVER)	IMPERIAL STANDPIPE	METRIC STANDPIPE	METRIC STANDPIPE 45° TUBE BEND	METRIC STANDPIPE 90° TUBE BEND	TUBE BITE

TUBE BITE

INTRODUCTION

HOSE

COUPLINGS

ADAPTORS

TECHNICAL

**SAE FLANGE CODE 61**

<b>T2130</b> P227			<b>T2150</b> P227			<b>T2170</b> P228
<b>T4130</b> P248			<b>T4150</b> P248			<b>T4170</b> P248
<b>T6130</b> P258	<b>T6140</b> P258	<b>T6290</b> P259	<b>T6150</b> P259	<b>T6300</b> P259	<b>T6160</b> P260	<b>T6170</b> P260
<b>T7130</b> P290	<b>T7140</b> P290	<b>T7290</b> P292	<b>T7150</b> P291	<b>T7300</b> P291	<b>T7160</b> P292	<b>T7170</b> P293
CODE 61 FLANGE	CODE 61 FLANGE 22.5° TUBE BEND	CODE 61 FLANGE 30° TUBE BEND	CODE 61 FLANGE 45° TUBE BEND	CODE 61 FLANGE 60° TUBE BEND	CODE 61 FLANGE 67.5° TUBE BEND	CODE 61 FLANGE 90° TUBE BEND

**SAE FLANGE CODE 61 cont'd**

<b>T4173</b> P248				
<b>T7171</b> P293	<b>T7172</b> P293	<b>T7173</b> P293	<b>T7174</b> P294	<b>T7910</b> P294
CODE 61 FLANGE 90° SPECIAL TUBE BEND	CODE 61 FLANGE 90° SPECIAL TUBE BEND	CODE 61 FLANGE 90° LONG TUBE BEND	CODE 61 FLANGE 90° SPECIAL TUBE BEND	CODE 61 FLANGE 110° TUBE BEND

**SAE FLANGE CODE 62**

<b>T6330</b> P261	<b>T6334</b> P261	<b>T6440</b> P262	<b>T6450</b> P263	<b>T6350</b> P264	<b>T6460</b> P268	<b>T6360</b> P266	<b>T6370</b> P269	<b>T6930</b> P270
<b>T7330</b> P294	<b>T7334</b> P294	<b>T7440</b> P294	<b>T7450</b> P294	<b>T7350</b> P295	<b>T7460</b> P295	<b>T7360</b> P295	<b>T7370</b> P296	<b>T7930</b> P296
CODE 62 FLANGE	CODE 62 D-RING FLANGE	CODE 62 FLANGE 22.5° TUBE BEND	CODE 62 FLANGE 30° TUBE BEND	CODE 62 FLANGE 45° TUBE BEND	CODE 62 FLANGE 60° TUBE BEND	CODE 62 FLANGE 67.5° TUBE BEND	CODE 62 FLANGE 90° TUBE BEND	CODE 62 FLANGE 110° TUBE BEND

**SPECIAL FLANGE RYCO CODE 62C**

<b>T6333</b> P261	<b>T6443</b> P262	<b>T6444</b> P263	<b>T6453</b> P263	<b>T6454</b> P263	<b>T6353</b> P264	<b>T6354</b> P265	<b>T6463</b> P268	<b>T6464</b> P268
<b>T7333</b> P296	<b>T7443</b> P296	<b>T7444</b> P297	<b>T7453</b> P298	<b>T7454</b> P298	<b>T7353</b> P298	<b>T7354</b> P298	<b>T7463</b> P298	<b>T7464</b> P298
RYCO CODE 62C FLANGE	RYCO CODE 62C FLANGE 22.5° TUBE BEND	RYCO CODE 62C D-RING FLANGE 22.5° TUBE BEND	RYCO CODE 62C FLANGE 30° TUBE BEND	RYCO CODE 62C D-RING FLANGE 30° TUBE BEND	RYCO CODE 62C FLANGE 45° TUBE BEND	RYCO CODE 62C D-RING FLANGE 45° TUBE BEND	RYCO CODE 62C FLANGE 60° TUBE BEND	RYCO CODE 62C D-RING FLANGE 60° TUBE BEND

**SPECIAL FLANGE RYCO CODE 62C cont'd**

<b>T6363</b> P267	<b>T6364</b> P267	<b>T6373</b> P269	<b>T6374</b> P268	<b>T6933</b> P270	<b>T6335</b> P261	<b>T6912</b> P261	<b>T6445</b> P262
<b>T7363</b> P298	<b>T7364</b> P299	<b>T7378</b> P299	<b>T7373</b> P299	<b>T7374</b> P300	<b>T7933</b> P299		
RYCO CODE 62C FLANGE 67.5° TUBE BEND	RYCO CODE 62C D-RING FLANGE 67.5° BEND	RYCO CODE 62C D-RING FLANGE 90° BEND	RYCO CODE 62C FLANGE 90° TUBE BEND	RYCO CODE 62C D-RING FLANGE 110° TUBE BEND	RYCO CODE 62C FLANGE 110° TUBE BEND	RYCO CODE 62K FLANGE	RYCO CODE 62C FLANGE 15° TUBE BEND





**SPECIAL FLANGE RYCO CODE 62K**

<b>T6455</b> P264	<b>T6355</b> P265	<b>T6359</b> P265	<b>T6465</b> P265	<b>T6914</b> P266	<b>T6916</b> P266	<b>T6918</b> P266	<b>T6375</b> P269	<b>T6936</b> P270
RYCO CODE 62K FLANGE 30° TUBE BEND	RYCO CODE 62K FLANGE 45° TUBE BEND	RYCO CODE 62K D-RING FLANGE 45° TUBE BEND	RYCO CODE 62K FLANGE 60° TUBE BEND	RYCO CODE 62K FLANGE 70° TUBE BEND	RYCO CODE 62K FLANGE 75° TUBE BEND	RYCO CODE 62K FLANGE 80° TUBE BEND	RYCO CODE 62K FLANGE 90° TUBE BEND	RYCO CODE 62K FLANGE 100° TUBE BEND



# COUPLINGS

## PICTORIAL INDEX

SPECIAL  
FLANGE  
RYCO  
CODE 62K



T6932 P270	T6914 P266	T6916 P266	T6918 P267	T6375 P269
				
RYCO CODE 62K FLANGE 110° TUBE BEND	RYCO CODE 62K FLANGE 70° TUBE BEND	RYCO CODE 62K FLANGE 75° TUBE BEND	RYCO CODE 62K FLANGE 80° TUBE BEND	RYCO CODE 62K FLANGE 90° TUBE BEND

HAMMER  
UNION









T61502 P271	T61501 P271
T71502 P302	T71501 P302
	
FIG 1502 MALE (WITH NUT)	FIG 1502 FEMALE (WITH SEAL)



**TW4000 ONE-PIECE CRIMP INTERLOK WATERBLAST COUPLINGS. INTERNAL/EXTERNAL SKIVE**











TW4090 P323	TW4027 P323	TW4711 P323
		
NPT MALE 60° SEAT	BSPP FEMALE O RING 60° SEAT	DKOS FEMALE METRIC O RING (HEAVY) 24° CONE











**TG000 ONE-PIECE CRIMP COUPLINGS FOR TPGL SERIES HOSE (GREASELINE)**

TG010 P321	TG320 P321	TG090 P321	TG320N P321	TG030 P322	TG020 P321	TG020N P322	TG040 P322
							
BSPT MALE	BSPT MALE SWIVEL	NPT MALE	NPT MALE SWIVEL	JIC MALE	BSPP FEMALE	NPSM FEMALE	JIC FEMALE

**8000 PUSH-ON COUPLINGS FOR PL1, PL1D, PL1PV AND RQP6 SERIES HOSE**

PL1, PL1D, PL1PV and RQP6 Hose simply pushes on to 8000 Series couplings. Clamps are required for critical applications, and when Working Pressure exceeds 50% of the Maximum Static Working Pressure. Do not overtighten Clamps as this will damage hose.











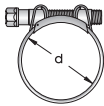



8010/S P325	8111 P325	8090 P325	8030 P326	8530 P328	8740 P329	8200 P330	8020 P324	8040 P327	8540 P329
									
BSPT MALE	BSPP O RING MALE	NPT MALE	JIC / SAE MALE	JIC / SAE MALE	SAE INVERTED FLARE MALE	UN O RING MALE (O RING BOSS)	BSPP FEMALE	JIC / SAE FEMALE	JIC / SAE FEMALE

8060 P325	8050 P325	8070 P327	8570 P329	8240 P327	8900 P328	8230 P330	8180 P330	8640 P331	8100 P331
									
BSPP FEMALE 45° ELBOW	BSPP FEMALE 90° ELBOW	JIC / SAE FEMALE 90° ELBOW	JIC / SAE FEMALE 90° ELBOW	JIC FEMALE 90° TUBE BEND	JOINER	SALVAGE (LIFE SAVER)	IMPERIAL STANDPIPE	METRIC STANDPIPE	200 AIR COUPLING NIPPLE

# COUPLINGS

## PICTORIAL INDEX

### 33000 SUCTION AND RETURN COUPLINGS FOR SRX AND SRF SERIES HOSE

<b>RSC</b> P332	<b>33010</b> P334	<b>33111</b> P332	<b>33090</b> P335	<b>33200</b> P338	<b>33400</b> P335	<b>33410</b> P333	<b>33400N</b> P335	<b>33420</b> P338	<b>33020</b> P333
									
SUCTION HOSE CLAMP	BSPT MALE	BSPP O RING MALE	NPT MALE	UN O RING MALE (O RING BOSS)	BSPT MALE 90° ELBOW	BSPP O RING MALE 90° ELBOW	NPT MALE 90° ELBOW	UN O RING MALE (O RING BOSS) 90° ELBOW	BSPP FEMALE
<b>33024</b> P333	<b>33040</b> P336	<b>33130</b> P337	<b>33150</b> P337	<b>33170</b> P338					
									
BSPP FEMALE FLAT FACE	JIC FEMALE	CODE 61 FLANGE	CODE 61 FLANGE 45° TUBE BEND	CODE 61 FLANGE 90° TUBE BEND					

## FIELD ATTACHABLE FERRULES FOR 6000 SERIES INSERTS

The RYCO Field Attachable system consists of five ferrule styles, each specific to a hose type, and one common Insert. Field Attachable Inserts and Ferrules can be ordered individually, or as a complete coupling for specific hose types.

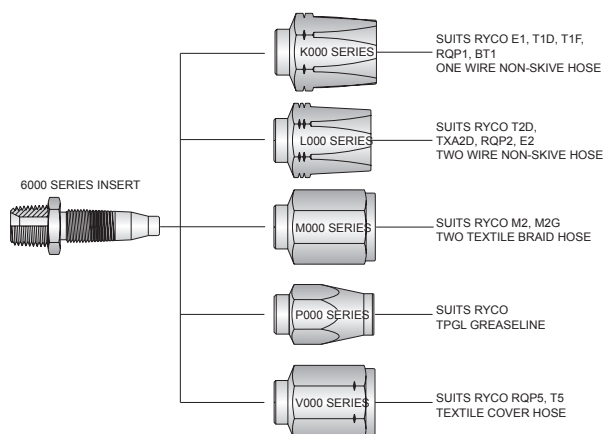

## FIELD ATTACHABLE FERRULES FOR 6000 SERIES INSERTS

K000 P353	L000 P353	M000 P353	P000 P353	V000 P353
SUITS RYCO E1, T1D, T1F, RQP1, BT1 ONE WIRE NON-SKIVE HOSE	SUITS RYCO E2, T2D, TXA2D, RQP2 TWO WIRE NON-SKIVE HOSE	SUITS RYCO M2, M2G TWO TEXTILE BRAID HOSE	SUITS RYCO TPGL GREASELINE	SUITS RYCO RQP5, T5 TEXTILE COVER

## 6000 SERIES FIELD ATTACHABLE INSERTS

6000 Series Inserts for K000, L000, V000, M000 and P000 ferrules.

<b>6010</b> P355	<b>6320</b> P356	<b>6090</b> P360	<b>6091</b> P360	<b>6320N</b> P362	<b>6860</b>	<b>6030</b> P363	<b>6650</b> P369	<b>6630</b> P371	<b>6530</b> P375
BSPT MALE	BSPT MALE SWIVEL	NPT MALE	NPT MALE EXTENDED	NPT MALE SWIVEL	GREASE LINE MALE	JIC MALE	METRIC DKL MALE 24° CONE	METRIC DKS MALE 24° CONE	SAE MALE
<b>6740</b> P378	<b>6200</b> P385	<b>6380</b> P384	<b>6750</b> P378	<b>6760</b> P378	<b>6340</b> P378	<b>6780</b> P378	<b>6790</b> P378	<b>6390</b> P385	<b>6770</b> P379
SAE INVERTED MALE FLARE	UN O RING MALE (O RING BOSS)	UN O RING MALE SWIVEL (O RING BOSS)	SAE INVERTED MALE FLARE 45° TUBE BEND	SAE INVERTED MALE FLARE 60° TUBE BEND	BSPT MALE SWIVEL 90° ELBOW	SAE INVERTED MALE FLARE 90° ELBOW	SAE INVERTED MALE FLARE 90° EXTENDED ELBOW	UN O RING MALE SWIVEL (O RING BOSS) 90° ELBOW	SAE INVERTED MALE FLARE 90° TUBE BEND
<b>6020</b> P355	<b>6024</b> P357	<b>6960B</b> P361	<b>6861</b> P359	<b>6040</b> P364	<b>6600</b> P369	<b>6711</b> P371	<b>6680</b> P368	<b>6800</b> P347	<b>6540</b> P376
BSPP FEMALE	BSPP FEMALE FLAT FACE	NPSM FEMALE LIVE SWIVEL	GREASE LINE FIXED FEMALE	JIC FEMALE	METRIC DKL FEMALE 24°/60° CONE	METRIC DKOS FEMALE 24° CONE	METRIC FEMALE 60° CONCAVE SEAT (UIS)	ORFS FEMALE	SAE FEMALE

INTRODUCTION

HOSE

COUPLINGS

ADAPTORS

TECHNICAL

# COUPLINGS

## PICTORIAL INDEX

### 6000 SERIES FIELD ATTACHABLE INSERTS (CONTINUED)

6000 Series Inserts for K000, L000, V000, M000 and P000 ferrules.

<b>6060</b> P357	<b>6080</b> P365	<b>6580</b> P376	<b>6270</b> P358	<b>6250</b> P366	<b>6660</b> P370	<b>6720</b> P372	<b>6810</b> P347	<b>6550</b> P377	<b>6050</b> P358
BSPP FEMALE 45° ELBOW	JIC FEMALE 45° ELBOW	SAE FEMALE 45° ELBOW	BSPP FEMALE 45° TUBE BEND	JIC FEMALE 45° TUBE BEND	METRIC DKL FEMALE 24°/60° CONE 45° TUBE BEND	METRIC DKOS FEMALE 24° CONE 45° TUBE BEND	ORFS FEMALE 45° TUBE BEND	SAE FEMALE 45° TUBE BEND	BSPP FEMALE 90° ELBOW
<b>6052</b> P357	<b>6070</b> P365	<b>6570</b> P376	<b>6260</b> P358	<b>6210</b> P359	<b>6240</b> P367	<b>6280</b> P368	<b>6670</b> P370	<b>6730</b> P372	<b>6820</b> P348
BSPP FEMALE FLAT FACE 90° ELBOW	JIC FEMALE 90° ELBOW	SAE FEMALE 90° ELBOW	BSPP FEMALE 90° TUBE BEND	BSPP FEMALE 90° LONG BEND	JIC FEMALE 90° TUBE BEND	JIC FEMALE 90° LONG BEND	METRIC DKL FEMALE 24°/60° CONE 90° TUBE BEND	METRIC DKOS FEMALE 24° CONE 90° TUBE BEND	ORFS FEMALE 90° TUBE BEND
<b>6830</b> P348	<b>6560</b> P377	<b>6563</b> P377	<b>6290</b>	<b>6150</b> P380	<b>6170</b> P381	<b>6230</b> P382	<b>6180</b> P383	<b>6640</b> P383	<b>6850</b> P384
ORFS FEMALE 90° LONG BEND	SAE FEMALE 90° TUBE BEND	SAE FEMALE 90° LONG BEND	CODE 61 FLANGE	CODE 61 FLANGE 45° TUBE BEND	CODE 61 FLANGE 90° TUBE BEND	SALVAGE (LIFESAVER)	IMPERIAL STANDPIPE	METRIC STANDPIPE	TUBE BITE

**“Index by End Style Number”** is a quick reference if the End Style Number is already known. It can also be used to show the availability of End Styles in different Coupling Series.

**Example:**

End Style of “013” BSPP Male is available in four Series:

**T2000** Series - **T2013** (page 187)

**T4000** Series - **T4013** (page 233)

**T6000** Series - **T6013** (page 250)

**T7000** Series - **T7013** (page 273)

END STYLE NUMBER	END STYLE DESCRIPTION	COUPLING SERIES & PAGE NUMBER										
		T2000	T4000	T6000	T7000	TP000	TT000	TG000	8000	33000	V000	6000
010	BSPT Male	187	233	250	272	250	317	321	325	334	341	355 361
013	BSPP Male	188	233	250	273							
014	BSPT Male Heavy				272							
017	BSPP Male Encapsulated Seal	189										
020	BSPP Female	190	234	251	273	303	317	321	324	333	341	355
020N	NPSM Female	199	236	252	278	307		322				
022	BSPP Female Heavy			251	273							
024	BSPP Female Flat Face	192								333		357
027	BSPP Female O Ring	195			275							
028B	BSPP Female Live Swivel	192	237									
030	JIC Male	200	237	252	278	307	318	322	326		343	363
031	JIC Male - Metric AF	200	237	252	278	307	318					
040	JSEAL™ / JIC Female	201	238	253	279	308	319	322	327	336	344	364 344
041	JSEAL™ / JIC Female - Metric AF	201	238		279	308	319					
045	JIC Female High-Pressure			253	279							
050	BSPP Female 90° Elbow	196	234		274	304	318		325			358
051	BSPP Female 90° Elbow - Metric AF											
052	BSPP Female Flat Face 90° Elbow - Metric AF											357
057	BSPP O Ring Female 90° Elbow - Metric AF	196			275							357
060	BSPP Female 45° Elbow	193			274				325			357
070	JSEAL™ / JIC Female 90° Elbow	167			280				327		345	365
071	JSEAL™ / JIC Female 90° Elbow - Metric AF	167			280				327			
080	JSEAL™ / JIC Female 45° Elbow	202			280							365
081	JSEAL™ / JIC Female 45° Elbow - Metric AF	202			280							365
090	NPTF Male	197	236	252	277	304	320	321	326	335	343	360 362
091	NPTF Male Extended	197		252	277							360
095	NPT Male - Metric AF											
100	Specials								331			
111	BSPP O Ring Male								325	332		
122	BSPP Female 60° Concave Seat (JIS) - Metric AF	205	241		282	304						
130	SAE Code 61 Flange	227	248	258	290					337		381
135	SAE Code 61 High Pressure Flange											
140	SAE Code 61 Flange 22.5° Tube Bend				290							
150	SAE Code 61 Flange 45° Tube Bend	227	248	259	291					337		380
160	SAE Code 61 Flange 67.5° Tube Bend				292							

INTRODUCTION

HOSE

COUPLINGS

ADAPTORS

TECHNICAL



# COUPLINGS

## INDEX BY END STYLE NUMBER

END STYLE NUMBER	END STYLE DESCRIPTION	COUPLING SERIES & PAGE NUMBER										
		T2000	T4000	T6000	T7000	TP000	TT000	TG000	8000	33000	V000	6000
170	SAE Code 61 Flange 90° Tube Bend	228	248	260	293					338		381
171	SAE Code 61 Flange 90° Special Tube Bend				293							
172	SAE Code 61 Flange 90° Special Tube Bend				293							
173	SAE Code 61 Flange 90° Long Tube Bend				293							
174	SAE Code 61 Flange 90° Special Tube Bend				294							
180	Imperial Standpipe	229							330			383
190	NPT Female Fixed	199										
200	UN O Ring Male (O Ring Boss)	231	249		302				330	324	352	385
202	UN O Ring Male (O Ring Boss) - Heavy											
210	BSPP Female 90° Long Tube Bend - Metric Af	195			275							359
220	BSPP Male 60° Convex Seat (JIS) - Metric Af	205										
230	Salvage / Lifesaver	228	247		301				330		352	382
240	JSEAL™ / JIC Female 90° Medium Tube Bend	204	240	254	281	309	319		327		346	367
241	JSEAL™ / JIC Female 90° Medium Tube Bend - Metric Af	204	240		281	309	319					
243	JSEAL™ / JIC Female 90° Short Tube Bend	203	240		281							
244	JSEAL™ / JIC Female 90° Short Tube Bend - Metric Af	203	240		281							
245	JSEAL™ / JIC Female High-Pressure 90° Tube Bend				281							
250	JSEAL™ / JIC Female 45° Tube Bend	203	239	253	280	309	319				345	366
251	JSEAL™ / JIC Female 45° Tube Bend - Metric Af		239		280	309						
255	JSEAL™ / JIC Female High-Pressure 45° Tube Bend											
260	BSPP Female 90° Tube Bend	194	234	251	274	304	318				342	358
267	BSPP O Ring Female 90° Tube Bend - Metric Af	196			276							
270	BSPP Female 45° Tube Bend	194		251	274	305					342	358
271	BSPP Female 45° Tube Bend - Metric Af											
277	BSPP O Ring Female 45° Tube Bend - Metric Af	196			276							
280	JSEAL™ / JIC Female 90° Long Tube Bend	204	240	254	282	310					346	368
281	JSEAL™ / JIC Female 90° Long Tube Bend - Metric Af	204	240			310					346	368
290	SAE Code 61 Flange 30° Tube Bend			258	292							
300	SAE Code 61 Flange 60° Tube Bend			258	291							
311	BSPP Female 60° Concave (JIS) 90° Tube Bend											
320	BSPT Male Swivel	191	233				317	321				356 356
320N	NPTF Male Swivel	198	236					321				362
330	SAE Code 62 Flange			261	294							
333	RYCO Code 62C Flange			261	296							
334	RYCO Code 62C D-Ring Flange			261	294							
335	RYCO Code 62K Flange			261								
340	BSPT Male Swivel 90° Elbow	191	234									356
340N	NPTF Male Swivel 90° Elbow	198				306						
350	SAE Code 62 Flange 45° Tube Bend			264	295							
353	RYCO Code 62C Flange 45° Tube Bend			264	298							
354	RYCO Code 62C D-Ring Flange 45° Tube Bend			265	298							
355	RYCO Code 62K Flange 45° Tube Bend			265								
359	RYCO Code 62K Flange 45° Long Tube Bend			265								
360	SAE Code 62 Flange 67.5° Tube Bend			266	295							
363	RYCO Code 62C Flange 67.5° Tube Bend			267	298							
364	RYCO Code 62C D-Ring Flange 67.5° Tube Bend			267	299							

## INDEX BY END STYLE NUMBER

END STYLE NUMBER	END STYLE DESCRIPTION	COUPLING SERIES & PAGE NUMBER										
		T2000	T4000	T6000	T7000	TP000	TT000	TG000	8000	33000	V000	6000
370	RYCO Code 62 Flange 90° Bend			269	296							
373	RYCO Code 62C Flange 90° Bend			269	299							
374	RYCO Code 62C D-Ring Flange 90° Tube Bend			268	300							
375	RYCO Code 62K Flange 90° Bend			269								
378	RYCO Code 62C D-Ring Flange 90° Long Tube Bend				299							
380	UN O Ring Male Swivel	231										384
390	UN O RING Male Swivel 90° Elbow	232										
400	BSPT Male 90° Elbow									335		
400N	NPTF Male 90° Elbow									335		
410	BSPP O Ring Male 90° Elbow									333		
420	UN O Ring Male 90° Elbow									338		
440	SAE Code 62 Flange 22.5° Tube Bend			262	294							
443	RYCO Code 62C Flange 22.5° Tube Bend			262	296							
444	RYCO Code 62C D-Ring Flange 22.5° Tube Bend			263								
445	RYCO Code 62K Flange 22.5° Tube Bend			262								
450	SAE Code 62 Flange 30° Tube Bend			263	279							
453	RYCO Code 62C Flange 30° Tube Bend			263	298							
454	RYCO Code 62C D-Ring Flange 30° Tube Bend			263								
455	RYCO Code 62K Flange 30° Tube Bend			264								
460	SAE Code 62 Flange 60° Tube Bend			268	295							
463	RYCO Code 62C Flange 60° Tube Bend			268	298							
464	RYCO Code 62C D-Ring Flange 60° Tube Bend			268	298							
465	RYCO Code 62K Flange 60° Tube Bend			265								
470	Metric Banjo Straight	217				313						
475	BSP Banjo Straight	193				305						
480	RYCO WEO Male	218			289							
482	RYCO WEO Male 45° Tube Bend	223			289							
483	RYCO WEO Male 90° Tube Bend	223			289							
485	RYCO WEO Male O-Ring											
487	RYCO WEO Male O-Ring 90° Tube Bend											
501	DKOL Female	211			283	311						
510	DKOL Female 45° Tube Bend	211				311						
520	DKOL Female 90° Tube Bend	212				316						
530	SAE Male	224	245						328		349	375
540	SAE Female	225	181			316	320		329		349	376
550	SAE Female 45° Tube Bend		245								350	377
560	SAE Female 90° Tube Bend		246								350	377
563	SAE Female 90° Long Tube Bend											377
570	SAE Female 90° Elbow	225	245			316			329			376
580	SAE Female 45° Elbow	225										376
600	DKL Female 24°/ 60° Cone	209	241				320					369
610	DKM Female 60° Ball Seat	209	241				320					369
630	DKS Male	213	284	255	284	312						371
640	Metric Standpipe	229			300	314			331			383
643	Metric Standpipe 45° Tube Bend				300	314						
646	Metric Standpipe 90° Tube Bend					314						
650	DKL Male 24° Cone	208				310						369

INTRODUCTION

HOSE

COUPLINGS

ADAPTORS

TECHNICAL

# COUPLINGS

## INDEX BY END STYLE NUMBER

END STYLE NUMBER	END STYLE DESCRIPTION	COUPLING SERIES & PAGE NUMBER										
		T2000	T4000	T6000	T7000	TP000	TT000	TG000	8000	33000	V000	6000
660	DKL Female 45° Tube Bend	209	241									370
670	DKL Female 90° Tube Bend	210	242					320	320			370
680	Metric Female 60° Concave Seat (JIS)	206			282							368
682	Metric Female 60° Concave Seat (JIS) 45° Tube Bend	206			282							368
683	Metric Female 60° Concave Seat (JIS) 90° Tube Bend	206			282							368
711	DKOS Female 24° Cone	214		255	285	312						371
720	DKOS Female 24° Cone 45° Tube Bend	215		255	285	313						372
730	DKOS Female 24° Cone 90° Tube Bend	216		255	285	313						372
733	DKOS Female 90° Long Tube Bend											
740	SAE Inverted Male Flare	225	246								350	378
750	SAE Inverted Male Flare 45° Tube Bend	226	246						329		351	378
760	SAE Inverted Flare Male 60° Tube Bend	226										379
770	SAE Inverted Flare Male 90° Tube Bend	226	246									379
780	SAE Inverted Flare Male 90° Elbow	226										378
790	SAE Inverted Flare Male 90° Long Elbow	226										378
800	ORFS Female	219	243	256	286	315					347	347
801	ORFS Female - Metric AF	219	243	256	286	315						
810	ORFS Female 45° Tube Bend	220	244	181	287						347	347
811	ORFS Female 45° Tube Bend - Metric AF	220	244	256	287	315						
813	ORFS Female 45° Short Tube Bend											
820	ORFS Female 90° Medium Tube Bend	221	244	257	287	315					348	348
821	ORFS Female 90° Medium Tube Bend - Metric AF	221	244	257	287	315						
823	ORFS Female 90° Short Tube Bend	220			287							
824	ORFS Female 90° Short Tube Bend - Metric AF	220			287							
830	ORFS Female 90° Long Tube Bend	221	244		287						348	348
831	ORFS Female 90° Long Tube Bend - Metric AF	221			287							
840	ORFS Male	218	243	256	286							
841	ORFS Male - Metric AF											
850	Tube Bite	231	249									
860	Grease Line Male											359
861	Grease Line Fixed Female	200										359
864	RYCOLOK Male Hammer Ring											
865	RYCOLOK Male Easy Out											
866	SUPERLOK Male Hammer Ring											
867	SUPERLOK Male Easy Out											
870	RYCOLOK Male	222	247	181	288							
871	RYCOLOK Male 45° Elbow	222			288							
872	RYCOLOK Male 90° Elbow	222			288							
874	RYCOLOK Fixed Female											
876	SUPERLOK Male			257	288							
900	Joiner	207		254	283				328			
901	Joiner 90° Tube Bend											
910	SAE Code 61 Flange 110° Tube Bend				294							
912	RYCO Code 62K Flange 15° Tube Bend			261								
914	RYCO Code 62K Flange			266								
916	RYCO Code 62K Flange 75° Tube Bend			266								

## INDEX BY END STYLE NUMBER

END STYLE NUMBER	END STYLE DESCRIPTION	COUPLING SERIES & PAGE NUMBER										
		T2000	T4000	T6000	T7000	TP000	TT000	TG000	8000	33000	V000	6000
<b>918</b>	RYCO Code 62K Flange 80° Tube Bend			267								
<b>930</b>	SAE Code 62 Flange 110° Tube Bend			270	296							
<b>932</b>	RYCO Code 62k Flange 100° Bend			270								
<b>933</b>	RYCO Code 62C Flange 110° Tube Bend			270	299							
<b>936</b>	RYCO Code 62K Flange 100° Tube Bend			270								
<b>940</b>	Pressure Washer Female	221										
<b>950</b>	Pressure Washer Gun Handle Tube	221										
<b>960B</b>	NPSM Female Live Swivel											361
<b>1501</b>	Figure 1502 Hammer Union Female (male thread)			271	302							
<b>1502</b>	Figure 1502 Hammer Union Male (with nut)			271	302							
<b>1502A</b>	Figure 1502 Hammer Union Male (reduced head dia.)											

INTRODUCTION

HOSE

COUPLINGS

ADAPTORS

TECHNICAL

### WORKING PRESSURE OF HOSE ASSEMBLIES

Working Pressure of each Hose Coupling End Style Termination is shown in the Technical section. In most cases, the Working Pressure of the Hose Coupling End Style Termination that can be chosen for a particular hose exceeds the Maximum Working Pressure of the Hose. It is possible however, to select a Hose Coupling with an End Style having a lower Working Pressure than the Hose. In this case, as noted in SAE J516 and SAE J517, the rated Working Pressure of the Hose Assembly must not exceed the lower of the respective Working Pressure rated values.

#### EXAMPLE 1.

**T28D** Hose Assembly with **T2040-0812** coupling one end and **T2090-0808** coupling other end.

From page 101 Maximum Working Pressure of **T28D** is 350 bar.

From page 201 and the technical section pages 494 to 498 the Maximum Working Pressure of **T2040-0812** is 690 bar.

From page 197 and the technical section pages 494 to 498 the Maximum Working Pressure of **T2090-0808** is 690 bar.

The Maximum Working Pressure of the Hose Assembly is therefore 350 bar, the lowest of the respective Maximum Working Pressure rated values (in this case, the hose).

#### EXAMPLE 2.

**H5016D** Hose Assembly with **T7130-1620** coupling one end and **T7030-1621** coupling other end.

From page 78 Maximum Working Pressure of **H5016D** is 350 bar.

From page 290 and the technical section pages 494 to 498 the Maximum Working Pressure of **T7130-1620** is 280 bar.

From page 278 and the technical section pages 494 to 498 the Maximum Working Pressure of **T7030-1621** is 420 bar.

The Maximum Working Pressure of the Hose Assembly is therefore 280 bar, the lowest of the respective Maximum Working Pressure rated values (in this case, the **T7130-1620**).

### 33000 SERIES COUPLINGS FOR SRX AND SRF SERIES HOSE

The Maximum Working Pressure of a **SRX** or **SRF** Series Hose Assembly depends on the couplings used, and the method of attachment. See pages 126 and 127

**33000** Series Couplings with **RSC** Clamps are suited to Suction Applications, and Low Pressure Delivery (up to 25% of Maximum Working Pressure of the hose).

**T4000** One-Piece Crimp Couplings are suited to Suction Applications, and High Pressure Delivery (up to 100% of Maximum Working Pressure of the hose).

#### EXAMPLE:

**SRF20** Hose Assembly with **33020-2020** Couplings each end secured with **RSC-4347** Clamps.

From page 127 Maximum Working Pressure of **SRF20** hose is 14 bar.

From page 184 and the technical section pages 494 to 498 the Maximum Working Pressure of **33020-2020** coupling is 215 bar. Maximum Working Pressure of the Hose Assembly is 25% of 14 bar = 3,5 bar.

If this Hose Assembly was made with **T4020-2020** One-Piece Crimp Couplings instead:

From page 127 Maximum Working Pressure of **SRF20** hose is 14 bar.

From page 234 and the technical section pages 494 to 498 the Maximum Working Pressure of **T4020-2020** coupling is 215 bar. Maximum Working Pressure of the Hose Assembly is 100% of 14 bar = 14 bar.

### 8000 SERIES COUPLINGS FOR PL1 AND RQP6 SERIES HOSE

**PL1**, **PL1D**, **PL1PV** and **RQP6** Series hose, and **8000** Series Push-On Fittings, are recommended for use in systems with Static Working Pressures (constant loads without pressure spikes) only. They are not recommended for vibration or pressure surge applications.

**PL1**, **PL1D**, **PL1PV** and **RQP6** Series hose should not be used at both maximum working pressure and maximum temperature simultaneously.

**8000** Series Push-On pages 324 to 331.

Assembly Instructions page 482.

**PL1**, **PL1D**, **PL1PV** and **RQP6** Series hose simply pushes on to **8000** Series Couplings, and for Static Working Pressures up to 50% of Maximum Static Working Pressures a clamp is not required. For diesel fuel and other potentially dangerous or critical applications, and Static Working Pressures above 50% of maximum; a clamp around the hose is required. Do not overtighten clamp as this will damage hose. Factory crimped couplings are also available in some sizes. Contact RYCO for more information.

### DROP LENGTH & CUT-OFF ALLOWANCE DIMENSIONS FOR COUPLINGS

In this Product Technical Manual, dimensional values for Drop Length (DL), Cut-off Allowance (CA), Seat to Ferrule (L), Back up Hex (AF), Male Hex (HM) and Female Hex (HF) are published.

Due to different manufacturing methods and design changes, DL, CA, L, AF, HM and HF values may vary from time to time.

Before attaching couplings to the hose, measure and check that the DL, CA and L dimensions of the actual coupling to be used complies with that published, or is suitable for the application.

**NOTE: Drop Length (DL), Cut-off Allowance (CA), Seat to Ferrule (L), Back up Hex (AF), Male Hex (HM) and Female Hex (HF) dimensions shown are for reference only, and may vary according to manufacturing method.**



## T2000 SERIES ONE-PIECE CRIMP COUPLINGS

### HOSE COMPATIBILITY FOR T2000 SERIES

#### NON-SKIVE

For RYCO Hose Series T3000D/S (sizes -04 to -16).  
 For RYCO Hose Series T3600D/S (sizes -04 to -16).  
 For RYCO Hose Series T4000D/S (sizes -04 to -12).  
 For RYCO Hose Series T5000D/S (sizes -04 to -08).  
 For RYCO Hose Series T6000D/S (sizes -04 to -06).  
 For RYCO Hose Series RQP1 (sizes -04 to -16).  
 For RYCO Hose Series E1, E2/C, T1D/S, T2D/S (sizes -03 to -48).  
 For RYCO Hose Series TJD (sizes -24 to -26)..

#### NON-SKIVE (CONTINUED)

For RYCO Hose Series DF2D (sizes -04 to -20).  
 For RYCO Hose Series D2B (sizes -24 to -32).  
 For RYCO Hose Series JS4000/B/G/BX/GX (sizes -04 to -08).  
 For RYCO Hose Series JS6000/B/G/BX/GX (sizes -04 to -08).  
 For RYCO Hose Series TW (sizes -04 to -08).  
 For RYCO Hose Series PW (sizes -04 to -06).  
 For RYCO Hose Series BT1 (sizes -04 to -16).  
 For RYCO Hose Series MS1000 (sizes -08 to -32).

### BSPT

### T2010

60° SEAT

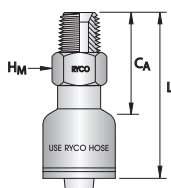

HOSE SIZE		THRD SIZE	DASH SIZE	MALE HEX		BSPT MALE				
DN	inch	inch		HM-SPANNER		PART NO	CA		L	
				inch	mm		inch	mm	inch	mm
5	3/16	1/8	-0302		14	<b>T2010-0302</b>	0.91	23	1.69	43
6	1/4	1/8	-0402		14	<b>T2010-0402</b>	1.06	27	2.09	53
6	1/4	1/4	-0404		14	<b>T2010-0404</b>	1.26	32	2.24	57
6	1/4	3/8	-0406	3/4	19	<b>T2010-0406</b>	1.34	34	2.32	59
6	1/4	1/2	-0408	7/8	22	<b>T2010-0408</b>	1.54	39	2.56	65
8	5/16	3/8	-0506	3/4	19	<b>T2010-0506</b>	1.34	34	2.32	59
8	5/16	1/2	-0508	7/8	22	<b>T2010-0508</b>	1.57	40	2.56	65
10	3/8	1/4	-0604		14	<b>T2010-0604</b>	1.42	36	2.40	61
10	3/8	3/8	-0606	3/4	19	<b>T2010-0606</b>	1.38	35	2.36	60
10	3/8	1/2	-0608	7/8	22	<b>T2010-0608</b>	1.61	41	2.60	66
12	1/2	3/8	-0806	3/4	19	<b>T2010-0806</b>	1.50	38	2.48	63
12	1/2	1/2	-0808	7/8	22	<b>T2010-0808</b>	1.65	42	2.64	67
12	1/2	5/8	-0810	1.1/16	27	<b>T2010-0810</b>	1.73	44	2.72	69
12	1/2	3/4	-0812	1.1/16	27	<b>T2010-0812</b>	1.73	44	2.72	69
16	5/8	1/2	-1008	7/8	22	<b>T2010-1008</b>	1.61	41	2.83	72
16	5/8	5/8	-1010	1.1/16	27	<b>T2010-1010</b>	1.61	41	2.83	72
16	5/8	3/4	-1012	1.1/16	27	<b>T2010-1012</b>	1.61	41	2.83	72
19	3/4	3/4	-1212	1.1/16	27	<b>T2010-1212</b>	1.85	47	3.03	77
19	3/4	1	-1216		36	<b>T2010-1216</b>	2.09	53	3.23	82
25	1	1	-1616		36	<b>T2010-1616</b>	2.09	53	3.27	83
25	1	1.1/4	-1620		46	<b>T2010-1620</b>	2.17	55	3.39	86
31	1.1/4	1.1/4	-2020		46	<b>T2010-2020</b>	2.36	60	4.29	109
38	1.1/2	1.1/2	-2424	2	50	<b>T2010-2424</b>	2.17	55	4.21	107
51	2	2	-3232		65	<b>T2010-3232</b>	2.60	66	4.80	122
63	2.1/2	2.1/2	-4040	3	76	<b>T2010-4040</b>	2.83	72	5.87	149

**NOTE:** Hose Compatibility for the **T2000** series can be found on page 187.

# COUPLINGS

## T2000 SERIES ONE-PIECE CRIMP COUPLINGS

BSPP

T2013

60° SEAT

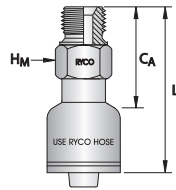

HOSE SIZE		THRD SIZE	DASH SIZE	MALE HEX		BSPP MALE				
DN	inch	inch		HM-SPANNER		PART NO	CA		L	
				inch	mm		inch	mm	inch	mm
5	3/16	1/8	-0302		14	<b>T2013-0302</b>	0.94	24	1.69	43
5	3/16	1/4	-0304	3/4	19	<b>T2013-0304</b>	1.14	29	1.89	48
6	1/4	1/8	-0402		14	<b>T2013-0402</b>	0.98	25	2.01	51
6	1/4	1/4	-0404	3/4	19	<b>T2013-0404</b>	1.34	34	2.32	59
6	1/4	3/8	-0406	7/8	22	<b>T2013-0406</b>	1.38	35	2.36	60
6	1/4	1/2	-0408	1.1/16	27	<b>T2013-0408</b>	1.54	39	2.52	64
8	5/16	1/4	-0504	3/4	19	<b>T2013-0504</b>	1.34	34	2.32	59
8	5/16	3/8	-0506	7/8	22	<b>T2013-0506</b>	1.38	35	2.36	60
10	3/8	1/4	-0604	3/4	19	<b>T2013-0604</b>	1.38	35	2.36	60
10	3/8	3/8	-0606	7/8	22	<b>T2013-0606</b>	1.46	37	2.44	62
10	3/8	1/2	-0608	1.1/16	27	<b>T2013-0608</b>	1.57	40	2.56	65
12	1/2	3/8	-0806	7/8	22	<b>T2013-0806</b>	1.46	37	2.44	62
12	1/2	1/2	-0808	1.1/16	27	<b>T2013-0808</b>	1.61	41	2.60	66
12	1/2	5/8	-0810	1.1/4	32	<b>T2013-0810</b>	1.73	44	2.72	69
12	1/2	3/4	-0812	1.1/4	32	<b>T2013-0812</b>	1.81	46	2.80	71
16	5/8	1/2	-1008	1.1/16	27	<b>T2013-1008</b>	1.50	38	2.72	69
16	5/8	5/8	-1010	1.1/4	32	<b>T2013-1010</b>	1.61	41	2.83	72
16	5/8	3/4	-1012	1.1/4	32	<b>T2013-1012</b>	1.69	43	2.91	74
19	3/4	1/2	-1208	1.1/16	27	<b>T2013-1208</b>	1.77	45	2.95	75
19	3/4	3/4	-1212	1.1/4	32	<b>T2013-1212</b>	1.85	47	3.03	77
25	1	3/4	-1612	1.1/4	32	<b>T2013-1612</b>	1.85	47	3.07	78
25	1	1	-1616	1.5/8	41	<b>T2013-1616</b>	2.01	51	3.23	82
25	1	1.1/4	-1620	2	50	<b>T2013-1620</b>	2.20	56	3.43	87
31	1.1/4	1.1/4	-2020	2	50	<b>T2013-2020</b>	2.36	60	4.29	109
38	1.1/2	1.1/2	-2424	2.3/16	55	<b>T2013-2424</b>	2.17	55	4.17	106
38	1.1/2	2	-2432	2.3/4	70	<b>T2013-2432</b>	2.36	60	4.41	112
51	2	2	-3232	2.3/4	70	<b>T2013-3232</b>	2.64	67	4.84	123

**NOTE:** Hose Compatibility for the **T2000** series can be found on page 187.

## T2000 SERIES ONE-PIECE CRIMP COUPLINGS

<b>BSPP</b>	<b>T2017</b>
-------------	--------------

**60° SEAT  
ENCAPSULATED  
SEAL INCLUDED**

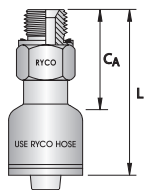

HOSE SIZE		THRD SIZE	DASH SIZE	MALE HEX		BSPP MALE ENCAPSULATED SEAL				
DN	inch	inch		HM-SPANNER		PART NO	CA		L	
				inch	mm		inch	mm	inch	mm
6	1/4	1/4	-0404	3/4	19	<b>T2017-0404</b>	1.34	34	2.32	59
10	3/8	3/8	-0606	7/8	22	<b>T2017-0606</b>	1.46	37	2.44	62
12	1/2	1/2	-0808	1.1/16	27	<b>T2017-0808</b>	1.61	41	2.60	66
19	3/4	3/4	-1212	1.1/4	32	<b>T2017-1212</b>	1.85	47	3.03	77
25	1	1	-1616	1.5/8	41	<b>T2017-1616</b>	2.01	51	3.23	82
31	1.1/4	1.1/4	-2020	2	50	<b>T2017-2020</b>	2.36	60	4.29	109

INTRODUCTION

HOSE

COUPLINGS

ADAPTORS

TECHNICAL

**NOTE:** Hose Compatibility for the **T2000** series can be found on page 187.

# COUPLINGS

## T2000 SERIES ONE-PIECE CRIMP COUPLINGS

<b>BSPP</b>	<b>T2020</b>
-------------	--------------

60° SEAT

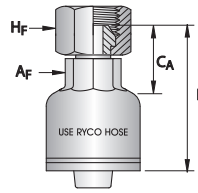

HOSE SIZE		THRD SIZE	DASH SIZE	BACK UP Af		FEMALE HEX		BSPP FEMALE				
DN	inch	inch		Af-SPANNER		Hf-SPANNER		PART NO	Ca		L	
				inch	mm	inch	mm		inch	mm	inch	mm
5	3/16	1/8	-0302		12		14	<b>T2020-0302</b>	0.87	22	1.61	41
5	3/16	1/4	-0304		12	3/4	19	<b>T2020-0304</b>	0.87	22	1.61	41
6	1/4	1/8	-0402		12		14	<b>T2020-0402</b>	0.87	22	1.89	48
6	1/4	1/4	-0404		12	3/4	19	<b>T2020-0404</b>	0.91	23	1.89	48
6	1/4	3/8	-0406		12	7/8	22	<b>T2020-0406</b>	1.06	27	2.05	52
8	5/16	1/4	-0504		14	3/4	19	<b>T2020-0504</b>	0.94	24	1.93	49
8	5/16	3/8	-0506		14	7/8	22	<b>T2020-0506</b>	1.02	26	2.05	52
10	3/8	1/4	-0604	5/8	16	3/4	19	<b>T2020-0604</b>	0.94	24	1.93	49
10	3/8	3/8	-0606	5/8	16	7/8	22	<b>T2020-0606</b>	1.02	26	2.01	51
10	3/8	1/2	-0608	5/8	16	1.1/16	27	<b>T2020-0608</b>	1.18	30	2.17	55
12	1/2	3/8	-0806	3/4	19	7/8	22	<b>T2020-0806</b>	1.06	27	2.05	52
12	1/2	1/2	-0808	3/4	19	1.1/16	27	<b>T2020-0808</b>	1.10	28	2.09	53
12	1/2	3/4	-0812	3/4	19	1.1/4	32	<b>T2020-0812</b>	1.26	32	2.24	57
16	5/8	1/2	-1008	7/8	22	1.1/16	27	<b>T2020-1008</b>	1.18	30	2.40	61
16	5/8	5/8	-1010	7/8	22	1.3/16	30	<b>T2020-1010</b>	1.14	29	2.36	60
16	5/8	3/4	-1012	7/8	22	1.1/4	32	<b>T2020-1012</b>	1.30	33	2.52	64
19	3/4	1/2	-1208	1.1/16	27	1.1/16	27	<b>T2020-1208</b>	1.34	34	2.52	64
19	3/4	3/4	-1212	1.1/16	27	1.1/4	32	<b>T2020-1212</b>	1.30	33	2.44	62
19	3/4	1	-1216	1.1/16	27	1.1/2	38	<b>T2020-1216</b>	1.54	39	2.72	69
25	1	3/4	-1612	1.1/4	32	1.1/4	32	<b>T2020-1612</b>	1.42	36	2.64	67
25	1	1	-1616	1.1/4	32	1.1/2	38	<b>T2020-1616</b>	1.50	38	2.72	69
25	1	1.1/4	-1620	1.1/4	32	2	50	<b>T2020-1620</b>	1.69	43	2.91	74
31	1.1/4	1.1/4	-2020	1.5/8	41	2	50	<b>T2020-2020</b>	1.77	45	3.70	94
38	1.1/2	1.1/2	-2424	2	50	2.3/16	55	<b>T2020-2424</b>	1.85	47	3.90	99
51	2	2	-3232		65	2.3/4	70	<b>T2020-3232</b>	2.17	55	4.37	111
63	2.1/2	2.1/2	-4040			3.1/2	90	<b>T2020-4040</b>	1.73	44	4.72	120

**NOTE:** Hose Compatibility for the **T2000** series can be found on page 187.

## T2000 SERIES ONE-PIECE CRIMP COUPLINGS

INTRODUCTION

HOSE

COUPLINGS

ADAPTORS

TECHNICAL

### BSPT T2320

60° SEAT

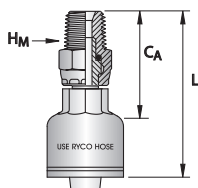

HOSE SIZE		THRD SIZE	DASH SIZE	MALE HEX		BSPT MALE SWIVEL				
DN	inch	inch		inch	mm	PART NO	C <sub>A</sub>		L	
							inch	mm	inch	mm
				H <sub>M</sub> -SPANNER						
10	3/8	3/8	-0606	5/8	16	<b>T2320-0606</b>	1.85	47	2.83	72
10	3/8	1/2	-0608	5/8	16	<b>T2320-0608</b>	2.05	52	3.03	77
12	1/2	1/2	-0808	3/4	19	<b>T2320-0808</b>	2.01	51	2.99	76

**NOTE:** The "Live Swivel" **T2320**, Series Couplings is for Maximum Working Pressure: 420 bar (6100 psi): -04 & -06 Thread Size, 350 bar (5100 psi): -08 Thread Size, 280 bar (4100 psi): -12 Thread Size, 215 bar (3100 psi): -16 Thread Size. Their swivel capability is to allow easy installation and orientation and avoid twisting of hose. They are not designed for continuous rotation or continuous movement.

### BSPT T2340

60° SEAT

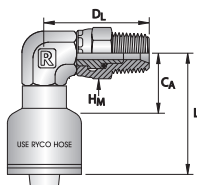

HOSE SIZE		THRD SIZE	DASH SIZE	MALE HEX		BSPT MALE SWIVEL 90° ELBOW						
DN	inch	inch		inch	mm	PART NO	C <sub>A</sub>		L		D <sub>L</sub>	
							inch	mm	inch	mm	inch	mm
10	3/8	3/8	-0606	3/4	19	<b>T2340-0606</b>	1.22	31	2.20	56	1.77	45
10	3/8	1/2	-0608	3/4	19	<b>T2340-0608</b>	1.22	31	2.20	56	1.97	50
12	1/2	1/2	-0808	7/8	22	<b>T2340-0808</b>	1.46	37	2.44	62	2.05	52
19	3/4	3/4	-1212	1.1/16	27	<b>T2340-1212</b>	1.57	40	2.72	69	1.77	45

**NOTE:** The "Live Swivel" **T2340** Series Couplings is for Maximum Working Pressure: 420 bar (6100 psi): -04 & -06 Thread Size, 350 bar (5100 psi): -08 Thread Size, 280 bar (4100 psi): -12 Thread Size, 215 bar (3100 psi): -16 Thread Size. Their swivel capability is to allow easy installation and orientation and avoid twisting of hose. They are not designed for continuous rotation or continuous movement.

**NOTE:** Hose Compatibility for the **T2000** series can be found on page 187.



# COUPLINGS

## T2000 SERIES ONE-PIECE CRIMP COUPLINGS

<b>BSPP</b>	<b>T2028B</b>
-------------	---------------

60° SEAT

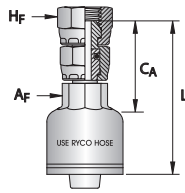

HOSE SIZE		THRD SIZE	DASH SIZE	BACK UP Af		FEMALE HEX		BSPP FEMALE LIVE SWIVEL					
DN	inch	inch		Af-SPANNER		Hf-SPANNER		PART NO	CA		L		
				inch	mm	inch	mm		inch	mm	inch	mm	
6	1/4	1/4	-0404	1/2		3/4	19	<b>T2028B-0404</b>	1.65	42	2.64	67	
10	3/8	1/4	-0604	5/8	16	3/4	19	<b>T2028B-0604</b>	1.73	44	2.72	69	

<b>BSPP</b>	<b>T2024</b>
-------------	--------------

FLAT FACE

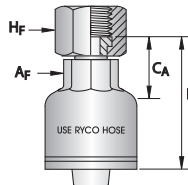

HOSE SIZE		THRD SIZE	DASH SIZE	BACK UP Af		FEMALE HEX		BSPP FEMALE FLAT FACE					
DN	inch	inch		Af-SPANNER		Hf-SPANNER		PART NO	CA		L		
				inch	mm	inch	mm		inch	mm	inch	mm	
6	1/4	1/4	-0404	1/2		3/4	19	<b>T2024-0404</b>	0.83	21	1.81	46	
10	3/8	3/8	-0606	5/8	16	7/8	22	<b>T2024-0606</b>	0.98	25	1.97	50	
10	3/8	1/2	-0608	5/8	16	1.1/16	27	<b>T2024-0608</b>	1.06	27	2.05	52	
12	1/2	1/2	-0808	3/4	19	1.1/16	27	<b>T2024-0808</b>	0.91	23	1.89	48	
12	1/2	3/4	-0812	3/4	19	1.1/4	32	<b>T2024-0812</b>	1.42	36	2.40	61	
19	3/4	3/4	-1212	1.1/16	27	1.1/4	32	<b>T2024-1212</b>	1.30	33	2.44	62	
19	3/4	1	-1216	1.1/16	27	1.1/2	38	<b>T2024-1216</b>	1.42	36	2.60	66	
25	1	1	-1616	1.1/4	32	1.1/2	38	<b>T2024-1616</b>	1.50	38	2.72	69	

**NOTE:** Hose Compatibility for the **T2000** series can be found on page 187.

## T2000 SERIES ONE-PIECE CRIMP COUPLINGS

### BSP - BANJO T2475

STRAIGHT

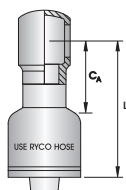

HOSE SIZE		THRD SIZE	DASH SIZE	BSP BANJO				
DN	inch	inch		PART NO	CA		L	
					inch	mm	inch	mm
6	1/4	1/4	-0404	<b>T2475-0404</b>	1.22	31	2.24	57
6	1/4	3/8	-0406	<b>T2475-0406</b>	1.30	33	2.32	59
6	1/4	1/2	-0408	<b>T2475-0408</b>	1.34	34	2.36	60
8	5/16	3/8	-0506	<b>T2475-0506</b>	1.42	36	2.40	61
10	3/8	1/4	-0604	<b>T2475-0604</b>	1.30	33	2.28	58
10	3/8	3/8	-0606	<b>T2475-0606</b>	1.38	35	2.36	60
10	3/8	1/2	-0608	<b>T2475-0608</b>	1.42	36	2.40	61
12	1/2	3/8	-0806	<b>T2475-0806</b>	1.42	36	2.40	61
12	1/2	1/2	-0808	<b>T2475-0808</b>	1.46	37	2.44	62
12	1/2	3/4	-0812	<b>T2475-0812</b>	1.57	40	2.56	65
16	5/8	5/8	-1010	<b>T2475-1010</b>	1.34	34	2.56	65
16	5/8	3/4	-1012	<b>T2475-1012</b>	1.46	37	2.68	68
19	3/4	3/4	-1212	<b>T2475-1212</b>	1.61	41	2.76	70
25	1	1	-1616	<b>T2475-1616</b>	1.89	48	3.11	79

**NOTE:** Other configurations available on request. For RL21D Seal see RYCO Adaptor Catalogue.

### BSP BANJO BOLT BBB

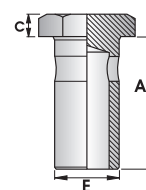

THREAD SIZE E	DIMENSIONS (MM)			BSP BANJO BOLT
	A	C	A/F	
inch				PART NO
G1/4"-19	28,5	6,0	19	<b>BBB-04</b>
G3/8"-19	38,5	7,0	22	<b>BBB-06</b>
G1/2"-14	44,0	8,5	27	<b>BBB-08</b>
G5/8"-14	48,5	10,0	30	<b>BBB-10</b>
G3/4"-14	56,0	10,0	32	<b>BBB-12</b>
G1"-11	68,5	13,0	41	<b>BBB-16</b>

**NOTE:** RL21D Seals for BBB Banjo Bolts can be found on page 402.

### BSPP T2060 T2050

60° SEAT

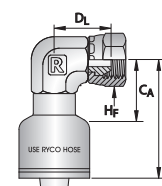
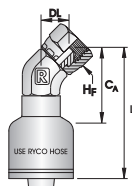

HOSE SIZE	THRD SIZE	DASH SIZE	FEMALE HEX		BSPP FEMALE 45° ELBOW						BSPP FEMALE 90° ELBOW								
			Hf	SPANNER	PART NO	CA		L		DL		PART NO	CA		L		DL		
DN	inch	inch	inch	mm		inch	mm	inch	mm	inch	mm	inch	mm	inch	mm	inch	mm	inch	mm
6	1/4	1/4	-0404	3/4	19	<b>T2060-0404</b>	0.83	21	1.85	47	0.59	15	<b>T2050-0404</b>	1.10	28	2.13	54	0.94	24
6	1/4	3/8	-0406	7/8	22								<b>T2050-0406</b>	1.10	28	2.13	54	1.10	28
8	5/16	3/8	-0506	7/8	22								<b>T2050-0506</b>	1.10	28	2.09	53	1.10	28
10	3/8	1/4	-0604	3/4	19								<b>T2050-0604</b>	1.18	30	2.17	55	0.94	24
10	3/8	3/8	-0606	7/8	22	<b>T2060-0606</b>	0.98	25	1.97	50	0.71	18	<b>T2050-0606</b>	1.22	31	2.20	56	1.10	28
10	3/8	1/2	-0608	1.1/16	27								<b>T2050-0608</b>	1.22	31	2.20	56	1.22	31
12	1/2	1/2	-0808	1.1/16	27	<b>T2060-0808</b>	1.14	29	2.13	54	0.71	18	<b>T2050-0808</b>	1.46	37	2.44	62	1.22	31
19	3/4	3/4	-1212	1.1/4	32	<b>T2060-1212</b>	1.34	34	2.48	63	0.79	20	<b>T2050-1212</b>	1.57	40	2.72	69	1.42	36
25	1	1	-1616	1.1/2	38	<b>T2060-1616</b>	1.38	35	2.60	66	1.02	26	<b>T2050-1616</b>	1.54	39	2.76	70	1.77	45
31	1.1/4	1.1/4	-2020	2	50	<b>T2060-2020</b>	1.46	37	3.43	87	1.14	29	<b>T2050-2020</b>	2.05	52	3.98	101	2.05	52
38	1.1/2	1.1/2	-2424	2.3/16	55								<b>T2050-2424</b>	2.36	60	4.41	112	2.32	59
51	2	2	-3232	2.3/4	70								<b>T2050-3232</b>	2.20	56	4.45	113	2.44	62

INTRODUCTION

HOSE

COUPLINGS

ADAPTORS

TECHNICAL

# COUPLINGS

## T2000 SERIES ONE-PIECE CRIMP COUPLINGS

<b>BSPP</b>	<b>T2270</b>	<b>T2260</b>
-------------	--------------	--------------

60° SEAT

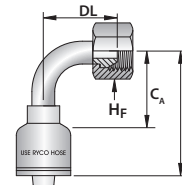
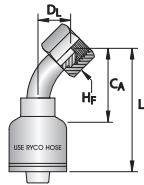

HOSE SIZE	THR D SIZE	DASH SIZE	FEMALE HEX	BSPP FEMALE 45° TUBE BEND							BSPP FEMALE 90° TUBE BEND									
				HF-SPANNER		PART NO	CA		L		DL		PART NO	CA		L		DL		
DN	inch	inch		inch	mm		inch	mm	inch	mm	inch	mm		inch	mm	inch	mm	inch	mm	
5	3/16	1/8	-0302		14									<b>T2260-0302</b>	1.06	27	1.85	47	1.14	29
5	3/16	1/4	-0304	3/4	19									<b>T2260-0304</b>	1.06	27	1.85	47	1.14	29
6	1/4	1/8	-0402		14									<b>T2260-0402</b>	1.06	27	2.05	52	1.18	30
6	1/4	1/4	-0404	3/4	19	<b>T2270-0404</b>	1.57	40	2.56	65	0.67	17	<b>T2260-0404</b>	1.26	32	2.24	57	1.14	29	
6	1/4	3/8	-0406	7/8	22	<b>T2270-0406</b>	1.61	41	2.60	66	0.71	18	<b>T2260-0406</b>	1.06	27	2.05	52	1.10	28	
8	5/16	1/4	-0504	3/4	19									<b>T2260-0504</b>	1.14	29	2.13	54	1.26	32
8	5/16	3/8	-0506	7/8	22	<b>T2270-0506</b>	1.61	41	2.60	66	0.71	18	<b>T2260-0506</b>	1.38	35	2.36	60	1.30	33	
10	3/8	1/4	-0604	3/4	19									<b>T2260-0604</b>	1.18	30	2.17	55	1.14	29
10	3/8	3/8	-0606	7/8	22	<b>T2270-0606</b>	1.61	41	2.60	66	0.71	18	<b>T2260-0606</b>	1.38	35	2.36	60	1.30	33	
10	3/8	1/2	-0608	1.1/16	27	<b>T2270-0608</b>	1.77	45	2.76	70	0.79	20	<b>T2260-0608</b>	1.38	35	2.36	60	1.30	33	
12	1/2	3/8	-0806	7/8	22									<b>T2260-0806</b>	1.61	41	2.60	66	1.30	33
12	1/2	1/2	-0808	1.1/16	27	<b>T2270-0808</b>	1.97	50	2.95	75	0.87	22	<b>T2260-0808</b>	1.61	41	2.60	66	1.77	45	
12	1/2	5/8	-0810	1.3/16	30	<b>T2270-0810</b>	1.93	49	2.91	74	0.91	23	<b>T2260-0810</b>	1.61	41	2.60	66	1.77	45	
12	1/2	3/4	-0812	1.1/4	32									<b>T2260-0812</b>	1.61	41	2.60	66	1.85	47
16	5/8	5/8	-1010	1.3/16	30	<b>T2270-1010</b>	2.44	62	3.66	93	0.91	23	<b>T2260-1010</b>	1.77	45	2.99	76	1.97	50	
12	1/2	3/4	-1012	1.1/4	32	<b>T2270-1012</b>	2.28	58	3.50	89	1.10	28	<b>T2260-1012</b>	1.77	45	2.76	70	1.97	50	
19	3/4	1/2	-1208	1.1/16	27									<b>T2260-1208</b>	2.17	55	3.35	85	1.77	45
19	3/4	3/4	-1212	1.1/4	32	<b>T2270-1212</b>	3.11	79	4.25	108	1.14	29	<b>T2260-1212</b>	2.32	59	3.50	89	2.32	59	
19	3/4	1	-1216	1.1/2	38									<b>T2260-1216</b>	2.32	59	3.50	89	2.32	59
25	1	1	-1616	1.1/2	38	<b>T2270-1616</b>	3.35	85	4.57	116	1.65	42	<b>T2260-1616</b>	2.68	68	3.90	99	3.07	78	
31	1.1/4	1	-2016	1.1/2	38									<b>T2260-2016</b>	3.54	90	5.47	139	3.03	77
31	1.1/4	1.1/4	-2020	2	50	<b>T2270-2020</b>	6.50	165	8.46	215	1.81	46	<b>T2260-2020</b>	3.94	100	5.87	149	3.58	91	
38	1.1/2	1.1/2	-2424	2.3/16	55	<b>T2270-2424</b>	5.04	128	7.09	180	2.05	52	<b>T2260-2424</b>	4.17	106	6.22	158	4.13	105	
51	2	2	-3232	2.3/4	70	<b>T2270-3232</b>	5.91	150	8.11	206	2.56	65	<b>T2260-3232</b>	5.39	137	7.60	193	5.20	132	

**NOTE:** Hose Compatibility for the **T2000** series can be found on page 187.

## T2000 SERIES ONE-PIECE CRIMP COUPLINGS

### BSPP T2210

60° SEAT

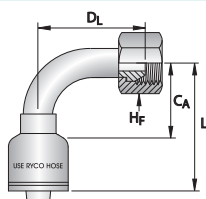

HOSE SIZE		THRD SIZE	DASH SIZE	FEMALE HEX		PART NO	BSPP FEMALE 90° LONG BEND		CA		L		DL	
DN	inch	inch		inch	mm		inch	mm	inch	mm	inch	mm	inch	mm
6	1/4	1/4	-0404	3/4	19	<b>T2210-0404</b>	2.36	60	3.35	85	2.01	51		
10	3/8	3/8	-0606	7/8	22	<b>T2210-0606</b>	1.93	49	2.91	74	2.32	59		
12	1/2	1/2	-0808	1.1/16	27	<b>T2210-0808</b>	2.36	60	3.35	85	2.83	72		
12	1/2	5/8	-0810	1.3/16	30	<b>T2210-0810</b>	2.36	60	3.35	85	2.83	72		
16	5/8	5/8	-1010	1.3/16	30	<b>T2210-1010</b>	2.01	51	3.23	82	3.19	81		
19	3/4	3/4	-1212	1.1/4	32	<b>T2210-1212</b>	2.32	59	3.50	89	3.74	95		
25	1	1	-1616	1.1/2	38	<b>T2210-1616</b>	2.56	65	3.78	96	4.57	116		
31	1.1/4	1.1/4	-2020	2	50	<b>T2210-2020</b>	4.21	107	6.14	156	1.81	46		

### BSPO T2027

60° SEAT  
O RING

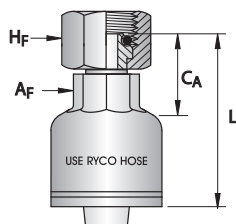

HOSE SIZE		THRD SIZE	DASH SIZE	BACK UP AF	FEMALE HEX		PART NO	BSPO FEMALE		L		
DN	inch	inch		inch	mm	inch		mm	inch	mm	inch	mm
6	1/4	1/8	-0402	1/2		9/16	14	<b>T2027-0402</b>	0.87	22	1.89	48
6	1/4	1/4	-0404	1/2		3/4	19	<b>T2027-0404</b>	0.91	23	1.89	48
6	1/4	3/8	-0406	1/2		7/8	22	<b>T2027-0406</b>	1.06	27	2.05	52
12	1/2	1/2	-0808	3/4	19	1.1/16	27	<b>T2027-0808</b>	1.10	28	2.09	53
19	3/4	3/4	-1212	1.1/16	27	1.1/4	32	<b>T2027-1212</b>	1.30	33	2.44	62
25	1	1	-1616	1.1/4	32	1.1/2	38	<b>T2027-1616</b>	1.50	38	2.72	69
31	1.1/4	1.1/4	-2020	1.5/8	41	2	50	<b>T2027-2020</b>	1.77	45	3.70	94
38	1.1/2	1.1/2	-2424	2	50	2.3/16	55	<b>T2027-2424</b>	1.85	47	3.90	99
51	2	2	-3232		65	2.3/4	70	<b>T2027-3232</b>	2.17	55	4.37	111

**NOTE:** Hose Compatibility for the **T2000** series can be found on page 187.

# COUPLINGS

## T2000 SERIES ONE-PIECE CRIMP COUPLINGS

<b>BSP0</b>	<b>T2057</b>
-------------	--------------

60° SEAT  
O RING

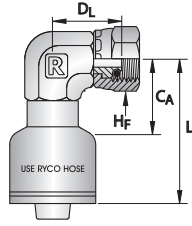

HOSE SIZE		THRD SIZE	DASH SIZE	FEMALE HEX		BSPO FEMALE 90° ELBOW						
DN	inch	inch		HF-SPANNER		PART NO	CA		L		DL	
				inch	mm		inch	mm	inch	mm	inch	mm
6	1/4	1/4	-0404	3/4	19	<b>T2057-0404</b>	1.10	28	2.13	54	0.94	24
10	3/8	3/8	-0606	7/8	22	<b>T2057-0606</b>	1.22	31	2.20	56	1.10	28
12	1/2	1/2	-0808	1.1/16	27	<b>T2057-0808</b>	1.46	37	2.44	62	1.30	33
19	3/4	3/4	-1212	1.1/4	32	<b>T2057-1212</b>	1.57	40	2.72	69	1.42	36

<b>BSP0</b>	<b>T2277</b>	<b>T2267</b>
-------------	--------------	--------------

60° SEAT  
O RING

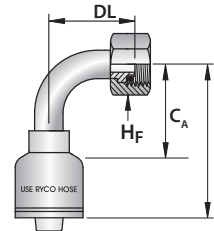
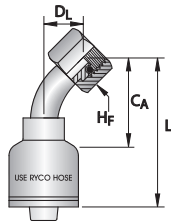

HOSE SIZE		THRD SIZE	DASH SIZE	FEMALE HEX		BSPO FEMALE 45° TUBE BEND						BSPO FEMALE 90° TUBE BEND							
DN	inch	inch		HF-SPANNER		PART NO	CA		L		DL		PART NO	CA		L		DL	
				inch	mm		inch	mm	inch	mm	inch	mm		inch	mm	inch	mm	inch	mm
6	1/4	1/8	-0402		14	<b>T2277-0402</b>	1.06	27	1.85	47	1.14	29	<b>T2267-0402</b>	1.06	27	2.05	52	1.18	30
6	1/4	1/4	-0404	3/4	19	<b>T2277-0404</b>	1.57	40	2.56	65	0.67	17	<b>T2267-0404</b>	1.26	32	2.24	57	1.14	29
10	3/8	3/8	-0606	7/8	22	<b>T2277-0606</b>	1.61	41	2.60	66	0.71	18	<b>T2267-0606</b>	1.38	35	2.36	60	1.30	33
12	1/2	1/2	-0808	1.1/16	27	<b>T2277-0808</b>	1.97	50	2.95	75	0.87	22	<b>T2267-0808</b>	1.61	41	2.60	66	1.77	45
19	3/4	3/4	-1212	1.1/4	32	<b>T2277-1212</b>	3.11	79	4.25	108	1.14	29	<b>T2267-1212</b>	2.32	59	3.50	89	2.32	59
25	1	1	-1616	1.1/2	38	<b>T2277-1616</b>	3.35	85	4.57	116	1.65	42	<b>T2267-1616</b>	2.68	68	3.90	99	3.07	78
31	1.1/4	1.1/4	-2020	2	50	<b>T2277-2020</b>	6.50	165	8.46	215	1.81	46	<b>T2267-2020</b>	3.94	100	5.87	149	3.58	91
38	1.1/2	1.1/2	-2424	2.3/16	55	<b>T2277-2424</b>	5.04	128	7.09	180	2.05	52	<b>T2267-2424</b>	4.17	106	6.22	158	4.13	105
51	2	2	-3232	2.3/4	70	<b>T2277-3232</b>	5.91	150	8.11	206	2.56	65	<b>T2267-3232</b>	5.39	137	7.60	193	5.20	132

**NOTE:** Hose Compatibility for the **T2000** series can be found on page 187.



## T2000 SERIES ONE-PIECE CRIMP COUPLINGS

<b>NPT</b>	<b>T2090</b>	<b>T2091</b>
------------	--------------	--------------

60° SEAT

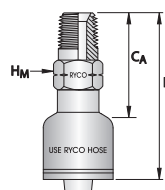
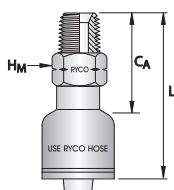

HOSE SIZE		THRD SIZE	DASH SIZE	MALE HEX	NPT MALE					NPT MALE EXTENDED					
DN	inch	inch		HM-SPANNER		PART NO	CA		L		PART NO	CA		L	
				inch	mm		inch	mm	inch	mm		inch	mm	inch	mm
5	3/16	1/8	-0302	1/2		<b>T2090-0302</b>	0.91	23	1.65	42					
5	3/16	1/4	-0304	9/16		<b>T2090-0304</b>	1.14	29	1.93	49					
6	1/4	1/8	-0402	1/2		<b>T2090-0402</b>	1.10	28	2.13	54					
6	1/4	1/4	-0404	9/16		<b>T2090-0404</b>	1.26	32	2.24	57					
6	1/4	3/8	-0406	3/4	19	<b>T2090-0406</b>	1.34	34	2.32	59	<b>T2091-0406</b>	1.61	41	2.64	67
6	1/4	1/2	-0408	7/8	22	<b>T2090-0408</b>	1.54	39	2.56	65					
8	5/16	1/4	-0504	9/16		<b>T2090-0504</b>	1.34	34	2.32	59					
8	5/16	3/8	-0506	3/4	19	<b>T2090-0506</b>	1.34	34	2.32	59					
10	3/8	1/4	-0604	9/16		<b>T2090-0604</b>	1.38	35	2.36	60					
10	3/8	3/8	-0606	3/4	19	<b>T2090-0606</b>	1.38	35	2.36	60	<b>T2091-0606</b>	1.69	43	2.68	68
10	3/8	1/2	-0608	7/8	22	<b>T2090-0608</b>	1.61	41	2.60	66					
12	1/2	3/8	-0806	3/4	19	<b>T2090-0806</b>	1.50	38	2.48	63					
12	1/2	1/2	-0808	7/8	22	<b>T2090-0808</b>	1.65	42	2.64	67					
12	1/2	3/4	-0812	1.1/16	27	<b>T2090-0812</b>	1.73	44	2.72	69					
16	5/8	1/2	-1008	7/8	22	<b>T2090-1008</b>	1.61	41	2.83	72					
16	5/8	3/4	-1012	1.1/16	27	<b>T2090-1012</b>	1.61	41	2.83	72					
19	3/4	1/2	-1208	7/8	22	<b>T2090-1208</b>	1.81	46	2.95	75					
19	3/4	3/4	-1212	1.1/16	27	<b>T2090-1212</b>	1.85	47	3.03	77					
19	3/4	1	-1216	1.3/8		<b>T2090-1216</b>	2.09	53	3.23	82					
25	1	3/4	-1612	1.1/16	27	<b>T2090-1612</b>	1.85	47	3.07	78					
25	1	1	-1616	1.3/8		<b>T2090-1616</b>	2.09	53	3.27	83					
25	1	1.1/4	-1620	1.3/4		<b>T2090-1620</b>	2.17	55	3.39	86					
31	1.1/4	1	-2016	1.3/8		<b>T2090-2016</b>	2.28	58	4.21	107					
31	1.1/4	1.1/4	-2020	1.3/4		<b>T2090-2020</b>	2.36	60	4.29	109					
38	1.1/2	1.1/2	-2424	2	50	<b>T2090-2424</b>	2.17	55	4.21	107					
51	2	2	-3232	2.1/2		<b>T2090-3232</b>	2.60	66	4.80	122					

**NOTE:** Hose Compatibility for the **T2000** series can be found on page 187.

# COUPLINGS

## T2000 SERIES ONE-PIECE CRIMP COUPLINGS

NPT

T2320N

60° SEAT

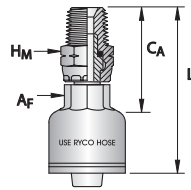

HOSE SIZE		THRD SIZE	DASH SIZE	BACK UP A <sub>F</sub>		MALE HEX		NPT MALE SWIVEL					
DN	inch	inch		A <sub>F</sub> -SPANNER		H <sub>M</sub> -SPANNER		PART NO		C <sub>A</sub>		L	
				inch	mm	inch	mm		inch	mm	inch	mm	
6	1/4	1/8	-0402	1/2		1/2		<b>T2320N-0402</b>	1.93	49	2.95	75	
6	1/4	1/4	-0404	1/2		1/2		<b>T2320N-0404</b>	1.69	43	2.72	69	
6	1/4	3/8	-0406	1/2		1/2		<b>T2320N-0406</b>	1.85	47	2.87	73	
10	3/8	1/4	-0604	5/8	16	5/8	16	<b>T2320N-0604</b>	1.81	46	2.80	71	
10	3/8	3/8	-0606	5/8	16	5/8	16	<b>T2320N-0606</b>	1.93	49	2.91	74	
10	3/8	1/2	-0608	5/8	16	5/8	16	<b>T2320N-0608</b>	2.09	53	3.07	78	
12	1/2	3/8	-0806	3/4	19	3/4	19	<b>T2320N-0806</b>	1.97	50	2.95	75	
12	1/2	1/2	-0808	3/4	19	3/4	19	<b>T2320N-0808</b>	2.13	54	3.11	79	
19	3/4	3/4	-1212	1.1/16	27	1.1/16	27	<b>T2320N-1212</b>	2.20	56	3.35	85	
25	1	1	-1616	1.1/4	32	1.1/4	32	<b>T2320N-1616</b>	2.56	65	3.78	96	

**NOTE:** The "Live Swivel" T2320N Series Coupling is for Maximum Working Pressure: 420 bar (6100 psi): -04 & -06 Thread Size, 350 bar (5100 psi): -08 Thread Size, 280 bar (4100 psi): -12 Thread Size, 215 bar (3100 psi): -16 Thread Size. Their swivel capability is to allow easy installation and orientation and avoid twisting of hose. They are not designed for continuous rotation or continuous movement.

NPT

T2340N

60° SEAT

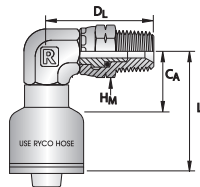

HOSE SIZE		THRD SIZE	DASH SIZE	MALE HEX		NPT MALE SWIVEL 90° ELBOW							
DN	inch	inch		H <sub>M</sub> -SPANNER		PART NO		C <sub>A</sub>		L		D <sub>L</sub>	
				inch	mm			inch	mm	inch	mm	inch	mm
6	1/4	1/4	-0404	9/16		<b>T2340N-0404</b>	1.10	28	2.13	54	1.61	41	
10	3/8	3/8	-0606	3/4	19	<b>T2340N-0606</b>	1.22	31	2.20	56	1.85	47	
12	1/2	1/2	-0808	7/8	22	<b>T2340N-0808</b>	1.46	37	2.44	62	2.09	53	
19	3/4	3/4	-1212	1.1/4	32	<b>T2340N-1212</b>	1.57	40	2.72	69	2.24	57	
25	1	1	-1616	1.5/16		<b>T2340N-1616</b>	1.54	39	2.76	70	2.80	71	

**NOTE:** The "Live Swivel" T2340N Series Coupling is for Maximum Working Pressure: 420 bar (6100 psi): -04 & -06 Thread Size, 350 bar (5100 psi): -08 Thread Size, 280 bar (4100 psi): -12 Thread Size, 215 bar (3100 psi): -16 Thread Size. Their swivel capability is to allow easy installation and orientation and avoid twisting of hose. They are not designed for continuous rotation or continuous movement.

**NOTE:** Hose Compatibility for the T2000 series can be found on page 187.

## T2000 SERIES ONE-PIECE CRIMP COUPLINGS

### NPT T2190

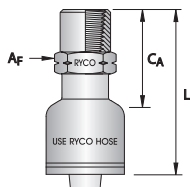

HOSE SIZE		THRD SIZE	DASH SIZE	BACK UP Af		NPT FIXED FEMALE					
DN	inch	inch		Af-SPANNER		PART NO	Ca		L		
				inch	mm		inch	mm	inch	mm	
6	1/4	1/8	-0402	9/16		<b>T2190-0402</b>	0.87	22	1.89	48	
6	1/4	1/4	-0404	3/4	19	<b>T2190-0404</b>	1.22	31	2.20	56	
6	1/4	3/8	-0406	7/8	22	<b>T2190-0406</b>	1.26	32	2.24	57	
10	3/8	1/4	-0604	3/4	19	<b>T2190-0604</b>	1.30	33	2.28	58	
10	3/8	3/8	-0606	7/8	22	<b>T2190-0606</b>	1.34	34	2.32	59	
10	3/8	1/2	-0608	1.1/16	27	<b>T2190-0608</b>	1.61	41	2.60	66	
12	1/2	3/8	-0806	7/8	22	<b>T2190-0806</b>	1.34	34	2.32	59	
12	1/2	1/2	-0808	1.1/16	27	<b>T2190-0808</b>	1.61	41	2.60	66	
16	5/8	3/4	-1012	1.3/8		<b>T2190-1012</b>	1.54	39	2.76	70	
19	3/4	3/4	-1212	1.3/8		<b>T2190-1212</b>	1.73	44	2.87	73	

### NPT T2020N

60° SEAT

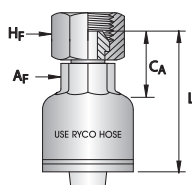

HOSE SIZE		THRD SIZE	DASH SIZE	BACK UP Af		FEMALE HEX		NPSM FEMALE				
DN	inch	inch		Af-SPANNER		Hf-SPANNER		Ca		L		
				inch	mm	inch	mm	inch	mm	inch	mm	
6	1/4	1/8	-0402	1/2		9/16		<b>T2020N-0402</b>	0.87	22	1.89	48
6	1/4	1/4	-0404	1/2		11/16		<b>T2020N-0404</b>	0.91	23	1.89	48
8	5/16	1/4	-0504		14	11/16		<b>T2020N-0504</b>	0.94	24	1.93	49
10	3/8	1/4	-0604	5/8	16	11/16		<b>T2020N-0604</b>	0.94	24	1.93	49
10	3/8	3/8	-0606	5/8	16	7/8	22	<b>T2020N-0606</b>	1.02	26	2.01	51
10	3/8	1/2	-0608	5/8	16	1.1/16	27	<b>T2020N-0608</b>	1.18	30	2.17	55
12	1/2	1/2	-0808	3/4	19	1.1/16	27	<b>T2020N-0808</b>	1.10	28	2.09	53
19	3/4	3/4	-1212	1.1/16	27	1.1/4	32	<b>T2020N-1212</b>	1.30	33	2.44	62
25	1	1	-1616	1.1/4	32	1.1/2	38	<b>T2020N-1616</b>	1.50	38	2.72	69
31	1.1/4	1.1/4	-2020	1.5/8	41	2	50	<b>T2020N-2020</b>	1.77	45	3.70	94
38	1.1/2	1.1/2	-2424	2	50	2.1/4	57	<b>T2020N-2424</b>	1.85	47	3.90	99
51	2	2	-3232		65	2.3/4	70	<b>T2020N-3232</b>	2.17	55	4.37	111

**NOTE:** Hose Compatibility for the **T2000** series can be found on page 187.

INTRODUCTION

HOSE

COUPLINGS

ADAPTORS

TECHNICAL

# COUPLINGS

## T2000 SERIES ONE-PIECE CRIMP COUPLINGS

<b>GREASE LINE</b>	<b>T2861</b>
--------------------	--------------

60° SEAT

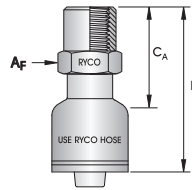

HOSE SIZE		THRD SIZE	DASH SIZE	BACK UP Af		GREASE LINE FIXED FEMALE				
DN	inch	inch		Af-SPANNER		PART NO	Ca		L	
				inch	mm		inch	mm	inch	mm
6	1/4	1/2 - 27 TPI	-0408	11/16		<b>T2861-0408</b>	1.14	29	2.17	55

<b>JIC - MALE</b>	<b>T2030 - T2031</b>
-------------------	----------------------

37° FLARE

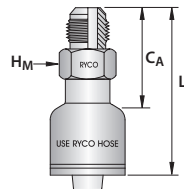

HOSE SIZE		THRD SIZE	TUBE SIZE	DASH SIZE	MALE HEX		JIC MALE				
DN	inch	inch	inch		Hm-SPANNER		PART NO	Ca		L	
					inch	mm		inch	mm	inch	mm
6	1/4	7/16	1/4	-0407	1/2		<b>T2030-0407</b>	1.26	32	2.28	58
					12		<b>T2031-0407</b>				
6	1/4	1/2	5/16	-0408		14	<b>T2030-0408</b>	1.22	31	2.24	57
6	1/4	9/16	3/8	-0409	5/8	16	<b>T2030-0409</b>	1.26	32	2.24	57
6	1/4	3/4	1/2	-0412	3/4	19	<b>T2030-0412</b>	1.42	36	2.40	61
8	5/16	1/2	5/16	-0508		14	<b>T2031-0508</b>	1.30	33	2.28	58
8	5/16	9/16	3/8	-0509	5/8	16	<b>T2030-0509</b>	1.26	32	2.24	57
10	3/8	9/16	3/8	-0609	5/8	16	<b>T2030-0609</b>	1.42	36	2.40	61
10	3/8	3/4	1/2	-0612	3/4	19	<b>T2030-0612</b>	1.46	37	2.44	62
10	3/8	7/8	5/8	-0614	15/16	24	<b>T2030-0614</b>	1.65	42	2.64	67
12	1/2	3/4	1/2	-0812	3/4	19	<b>T2030-0812</b>	1.57	40	2.56	65
12	1/2	7/8	5/8	-0814	15/16	24	<b>T2030-0814</b>	1.69	43	2.64	67
12	1/2	1.1/16	3/4	-0817	1.1/16	27	<b>T2030-0817</b>	1.81	46	2.80	71
16	5/8	7/8	5/8	-1014	15/16	24	<b>T2030-1014</b>	1.69	43	2.91	74
16	5/8	1.1/16	3/4	-1017	1.1/16	27	<b>T2030-1017</b>	1.69	43	2.91	74
19	3/4	7/8	5/8	-1214	15/16	24	<b>T2030-1214</b>	1.85	47	3.03	77
19	3/4	1.1/16	3/4	-1217	1.1/16	27	<b>T2030-1217</b>	1.97	50	3.15	80
19	3/4	1.3/16	7/8	-1219	1.1/4	32	<b>T2030-1219</b>	2.01	51	3.19	81
19	3/4	1.5/16	1	-1221	1.3/8		<b>T2030-1221</b>	2.05	52	3.19	81
					36		<b>T2031-1221</b>				
25	1	1.5/16	1	-1621	1.3/8		<b>T2030-1621</b>	2.01	51	3.23	82
					36		<b>T2031-1621</b>				
25	1	1.5/8	1.1/4	-1626	1.5/8	42	<b>T2030-1626</b>	2.17	55	3.39	86
31	1.1/4	1.5/8	1.1/4	-2026	1.5/8	42	<b>T2030-2026</b>	2.32	59	4.29	109
38	1.1/2	1.7/8	1.1/2	-2430	2	50	<b>T2030-2430</b>	2.24	57	4.29	109
51	2	2.1/2	2	-3240	2.1/2		<b>T2030-3240</b>	2.87	73	5.12	130

**NOTE:** Hose Compatibility for the **T2000** series can be found on page 187.

## T2000 SERIES ONE-PIECE CRIMP COUPLINGS

<b>JSEAL™ / JIC</b>	<b>T2040 - T2041</b>
---------------------	----------------------

**CONVEX SEAT**

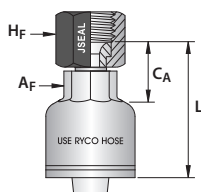

DN	HOSE SIZE		THRD SIZE	TUBE SIZE	DASH SIZE	BACK UP Af		FEMALE HEX		JSEAL™ / JIC FEMALE			
	inch	inch				inch	inch	mm	inch	mm	inch	mm	inch
5	3/16	7/16	1/4	-0307	1/2		9/16		<b>T2040-0307</b>	0.87	22	1.61	41
								12	<b>T2041-0307</b>				
6	1/4	3/8	3/16	-0406	1/2		1/2		<b>T2040-0406</b>	0.87	22	1.85	47
6	1/4	7/16	1/4	-0407	1/2		9/16		<b>T2040-0407</b>	0.75	19	1.73	44
						12		14	<b>T2041-0407</b>				
6	1/4	1/2	5/16	-0408	1/2		5/8	16	<b>T2040-0408</b>	0.83	21	1.85	47
6	1/4	9/16	3/8	-0409	1/2		11/16		<b>T2040-0409</b>	0.87	22	1.89	48
						12	3/4	19	<b>T2041-0409</b>				
6	1/4	3/4	1/2	-0412	1/2		7/8	22	<b>T2040-0412</b>	0.94	24	1.93	49
8	5/16	7/16	1/4	-0507		14	9/16		<b>T2040-0507</b>	0.87	22	1.85	47
						14		14	<b>T2041-0507</b>				
8	5/16	1/2	5/16	-0508		14	5/8	16	<b>T2040-0508</b>	0.87	22	1.85	47
8	5/16	9/16	3/8	-0509		14	11/16		<b>T2040-0509</b>	0.87	22	1.89	48
						14	3/4	19	<b>T2041-0509</b>				
8	5/16	3/4	1/2	-0512		14	7/8	22	<b>T2040-0512</b>	0.98	25	2.01	51
10	3/8	7/16	1/4	-0607	5/8	16	9/16		<b>T2040-0607</b>	0.87	22	1.85	47
					5/8	16		14	<b>T2041-0607</b>				
10	3/8	9/16	3/8	-0609	5/8	16	11/16		<b>T2040-0609</b>	0.87	22	1.85	47
					5/8	16	3/4	19	<b>T2041-0609</b>				
10	3/8	3/4	1/2	-0612	5/8	16	7/8	22	<b>T2040-0612</b>	1.02	26	2.01	51
10	3/8	7/8	5/8	-0614	5/8	16	1.1/16	27	<b>T2040-0614</b>	1.06	27	2.05	52
12	1/2	9/16	3/8	-0809	3/4	19	11/16		<b>T2040-0809</b>	1.69	43	2.68	68
					3/4	19	3/4	19	<b>T2041-0809</b>				
12	1/2	3/4	1/2	-0812	3/4	19	7/8	22	<b>T2040-0812</b>	0.94	24	1.93	49
12	1/2	7/8	5/8	-0814	3/4	19	1.1/16	27	<b>T2040-0814</b>	1.06	27	2.05	52
12	1/2	1.1/16	3/4	-0817	3/4	19	1.1/4	32	<b>T2040-0817</b>	1.22	31	2.20	56
16	5/8	3/4	1/2	-1012	7/8	22	7/8	22	<b>T2040-1012</b>	0.98	25	2.20	56
16	5/8	7/8	5/8	-1014	7/8	22	1.1/16	27	<b>T2040-1014</b>	1.06	27	2.24	57
16	5/8	1.1/16	3/4	-1017	7/8	22	1.1/4	32	<b>T2040-1017</b>	1.18	30	2.40	61
19	3/4	3/4	1/2	-1212	1.1/16	27	7/8	22	<b>T2040-1212</b>	1.18	30	2.36	60
19	3/4	7/8	5/8	-1214	1.1/16	27	1.1/16	27	<b>T2040-1214</b>	1.34	34	2.48	63
19	3/4	1.1/16	3/4	-1217	1.1/16	27	1.1/4	32	<b>T2040-1217</b>	1.22	31	2.40	61
19	3/4	1.3/16	7/8	-1219	1.1/16	27	1.3/8		<b>T2040-1219</b>	1.22	31	2.40	61
19	3/4	1.5/16	1	-1221	1.1/16	27	1.1/2	38	<b>T2040-1221</b>	1.50	38	2.68	68
25	1	1.1/16	3/4	-1617	1.1/4	32	1.1/4	32	<b>T2040-1617</b>	1.34	34	2.56	65
25	1	1.5/16	1	-1621	1.1/4	32	1.1/2	38	<b>T2040-1621</b>	1.38	35	2.60	66
25	1	1.5/8	1.1/4	-1626	1.1/4	32	2	50	<b>T2040-1626</b>	1.61	41	2.83	72
25	1	1.7/8	1.1/2	-1630	1.1/4	32	2.3/8	60	<b>T2040-1630</b>	1.85	47	3.07	78
31	1.1/4	1.5/8	1.1/4	-2026	1.5/8	41	2	50	<b>T2040-2026</b>	1.69	43	3.62	92
31	1.1/4	1.7/8	1.1/2	-2030	1.5/8	41	2.1/4	57	<b>T2040-2030</b>	2.05	52	3.98	101
38	1.1/2	1.7/8	1.1/2	-2430	2	50	2.1/4	57	<b>T2040-2430</b>	2.09	53	4.13	105
51	2	2.1/2	2	-3240		65	2.7/8	73	<b>T2040-3240</b>	2.44	62	4.65	118
63	2.1/2	3	2.1/2	-4048			3.1/2	90	<b>T2040-4048</b>	1.54	39	4.57	116

**NOTE:** Hose Compatibility for the **T2000** series can be found on page 187.

INTRODUCTION

HOSE

COUPLINGS

ADAPTORS

TECHNICAL



# COUPLINGS

## T2000 SERIES ONE-PIECE CRIMP COUPLINGS

JSEAL™ / JIC	T2080 - T2081	T2070 - T2071
--------------	---------------	---------------

CONVEX SEAT

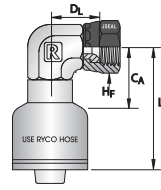
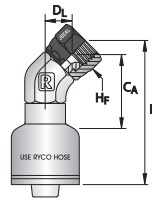

HOSE SIZE	THRDR SIZE	TUBE SIZE	DASH SIZE	FEMALE HEX	JSEAL™ / JIC FEMALE 45° ELBOW							JSEAL™ / JIC FEMALE 90° ELBOW								
					HF-SPANNER		PART NO	CA		L		DL		PART NO	CA		L		DL	
DN	inch	inch			inch	mm		inch	mm	inch	mm	inch	mm	inch	mm	inch	mm	inch	mm	
5	3/16	7/16	1/4	-0307	9/16	14								<b>T2070-0307</b>	0.87	22	1.61	41	0.71	18
														<b>T2071-0307</b>						
6	1/4	3/8	3/16	-0406	1/2		<b>T2080-0406</b>	1.34	34	2.36	60	0.51	13	<b>T2070-0406</b>	1.10	28	2.13	54	0.67	17
					9/16		<b>T2080-0407</b>	1.34	34	2.36	60	0.51	13	<b>T2070-0407</b>	1.10	28	2.13	54	0.67	17
6	1/4	7/16	1/4	-0407	14		<b>T2081-0407</b>							<b>T2071-0407</b>						
6	1/4	1/2	5/16	-0408	5/8	16	<b>T2080-0408</b>	0.83	21	1.85	47	0.51	13	<b>T2070-0408</b>	1.10	28	2.13	54	0.67	17
					11/16		<b>T2080-0409</b>	0.83	21	1.85	47	0.47	12	<b>T2070-0409</b>	1.10	28	2.13	54	0.87	22
6	1/4	9/16	3/8	-0409	3/4	19	<b>T2081-0409</b>							<b>T2071-0409</b>						
10	3/8	9/16	3/8	-0609	11/16	19	<b>T2080-0609</b>	0.98	25	1.97	50	0.55	14	<b>T2070-0609</b>	1.22	31	2.20	56	0.91	23
					3/4		<b>T2081-0609</b>							<b>T2071-0609</b>						
10	3/8	3/4	1/2	-0612	7/8	22	<b>T2080-0612</b>	0.98	25	1.97	50	0.59	15	<b>T2070-0612</b>	1.22	31	2.20	56	0.94	24
12	1/2	3/4	1/2	-0812	7/8	22	<b>T2080-0812</b>	1.14	29	2.13	54	0.63	16	<b>T2070-0812</b>	1.46	37	2.44	62	1.06	27
12	1/2	7/8	5/8	-0814	1.1/16	27	<b>T2080-0814</b>	1.14	29	2.13	54	0.67	17	<b>T2070-0814</b>	1.46	37	2.44	62	1.22	31
12	1/2	1.1/16	3/4	-0817	1.1/4	32								<b>T2070-0817</b>	1.46	37	2.44	62	1.26	32
19	3/4	1.1/16	3/4	-1217	1.1/4	32	<b>T2080-1217</b>	1.34	34	2.48	63	0.67	17	<b>T2070-1217</b>	1.57	40	2.72	69	1.26	32
25	1	1.5/16	1	-1621	1.1/2	38	<b>T2080-1621</b>	1.38	35	2.60	66	0.83	21	<b>T2070-1621</b>	1.54	39	2.76	70	1.50	38

**NOTE:** Hose Compatibility for the **T2000** series can be found on page 187.

## T2000 SERIES ONE-PIECE CRIMP COUPLINGS

<b>JSEAL™ / JIC</b>	<b>T2250 - T2251</b>	<b>T2243 - T2244</b>
---------------------	----------------------	----------------------

CONVEX SEAT

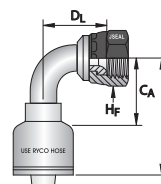
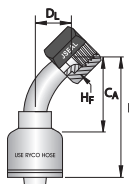

HOSE SIZE				THRSD SIZE	TUBE SIZE	DASH SIZE	FEMALE HEX	JSEAL™ / JIC FEMALE 45° TUBE BEND					JSEAL™ / JIC FEMALE 90° SHORT BEND										
DN	inch	inch	inch				HF-SPANNER		PART NO	CA		L		DL		PART NO	CA		L		DL		
							inch	mm		inch	mm	inch	mm	inch	mm		inch	mm	inch	mm	inch	mm	
6	1/4	7/16	1/4	-0407	9/16				<b>T2250-0407</b>	1.57	40	2.56	65	0.59	15	<b>T2243-0407</b>	1.46	37	2.44	62	0.83	21	
								14	<b>T2251-0407</b>							<b>T2244-0407</b>							
6	1/4	1/2	5/16	-0408	5/8	16			<b>T2250-0408</b>	1.30	33	2.28	58	0.59	15								
6	1/4	9/16	3/8	-0409	11/16				<b>T2250-0409</b>	1.30	33	2.28	58	0.59	15	<b>T2243-0409</b>	1.06	27	2.05	52	0.87	22	
					3/4	19			<b>T2251-0409</b>							<b>T2244-0409</b>							
8	5/16	9/16	3/8	-0509	11/16				<b>T2250-0509</b>	1.57	40	2.56	65	0.63	16								
					3/4	19			<b>T2251-0509</b>														
10	3/8	9/16	3/8	-0609	11/16				<b>T2250-0609</b>	1.50	38	2.48	63	0.55	14	<b>T2243-0609</b>	1.22	31	2.20	56	0.91	23	
					3/4	19			<b>T2251-0609</b>							<b>T2244-0609</b>							
10	3/8	3/4	1/2	-0612	7/8	22			<b>T2250-0612</b>	1.54	39	2.52	64	0.67	17								
12	1/2	3/4	1/2	-0812	7/8	22			<b>T2250-0812</b>	3.03	77	4.02	102	0.83	21	<b>T2243-0812</b>	1.69	43	2.68	68	1.14	29	
12	1/2	7/8	5/8	-0814	1.1/16	27			<b>T2250-0814</b>	1.85	47	2.83	72	0.87	22								
12	1/2	1.1/16	3/4	-0817	1.1/4	32			<b>T2250-0817</b>	1.85	47	2.83	72	0.83	21								
16	5/8	7/8	5/8	-1014	1.1/16	27			<b>T2250-1014</b>	2.44	62	3.66	93	0.94	24	<b>T2243-1014</b>	2.09	53	3.31	84	1.34	34	
16	5/8	1.1/16	3/4	-1017	1.1/4	32			<b>T2250-1017</b>	2.13	54	3.35	85	0.94	24								
19	3/4	7/8	5/8	-1214	1.1/16	27			<b>T2250-1214</b>	2.64	67	3.82	97	0.94	24	<b>T2243-1214</b>	2.09	53	3.27	83	1.34	34	
19	3/4	1.1/16	3/4	-1217	1.1/4	32			<b>T2250-1217</b>	3.11	79	4.25	108	1.10	28	<b>T2243-1217</b>	2.60	66	3.78	96	1.85	47	
19	3/4	1.3/16	7/8	-1219	1.3/8				<b>T2250-1219</b>	2.52	64	3.66	93	0.94	24								
19	3/4	1.5/16	1	-1221	1.1/2	38			<b>T2250-1221</b>	3.50	89	4.69	119	1.50	38								
25	1	1.1/16	3/4	-1617	1.1/4	32										<b>T2243-1617</b>	2.17	55	3.39	86	1.85	47	
25	1	1.5/16	115	-1621	1.1/2	38			<b>T2250-1621</b>	3.31	84	4.53	115	1.38	35	<b>T2243-1621</b>	3.19	81	4.41	112	2.28	58	
25	1	1.5/8	1.1/4	-1626	2	50			<b>T2250-1626</b>	5.39	137	6.61	168	1.54	39								
31	1.1/4	1.5/8	149	-2026	2	50			<b>T2250-2026</b>	3.94	100	5.87	149	1.54	39								
31	1.1/4	1.7/8	152	-2030	2.1/4	57			<b>T2250-2030</b>	4.06	103	5.98	152	1.65	42								
38	1.1/2	1.7/8	180	-2430	2.1/4	57			<b>T2250-2430</b>	5.04	128	7.09	180	1.97	50								
51	2	2.1/2	220	-3240	2.7/8	73			<b>T2250-3240</b>	6.46	164	8.66	220	2.48	63								

INTRODUCTION

HOSE

COUPLINGS

ADAPTORS

TECHNICAL

**NOTE:** Hose Compatibility for the **T2000** series can be found on page 187.

# COUPLINGS

## T2000 SERIES ONE-PIECE CRIMP COUPLINGS

<b>JSEAL™ / JIC</b>	<b>T2240 - T2241</b>	<b>T2280 - T2281</b>
---------------------	----------------------	----------------------

**CONVEX SEAT**

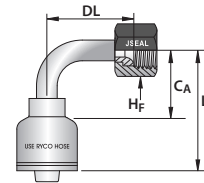
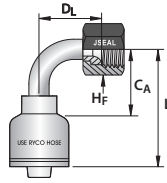

HOSE SIZE	THRD SIZE	TUBE SIZE	DASH SIZE	FEMALE HEX	JSEAL™ / JIC FEMALE 90° MEDIUM BEND							JSEAL™ / JIC FEMALE 90° LONG BEND								
					HF-SPANNER	PART NO	CA	L	DL	PART NO	CA	L	DL							
DN	inch	inch	inch		inch	mm	inch	mm	inch	mm	inch	mm	inch	mm	inch	mm	inch	mm	inch	mm
6	1/4	7/16	1/4	-0407	9/16		<b>T2240-0407</b>	1.54	39	2.52	64	1.26	32	<b>T2280-0407</b>	1.69	43	2.68	68	1.85	47
					14		<b>T2241-0407</b>							<b>T2281-0407</b>						
6	1/4	1/2	5/16	-0408	5/8	16	<b>T2240-0408</b>	1.26	32	2.24	57	1.26	32							
6	1/4	9/16	3/8	-0409	11/16		<b>T2240-0409</b>	1.30	33	2.28	58	1.50	38	<b>T2280-0409</b>	1.85	47	2.83	72	2.13	54
					3/4	19	<b>T2241-0409</b>							<b>T2281-0409</b>						
6	1/4	3/4	1/2	-0412	7/8	22	<b>T2240-0412</b>	1.02	26	2.01	51	1.50	38							
8	5/16	9/16	3/8	-0509	11/16		<b>T2240-0509</b>	1.38	35	2.36	60	1.18	30							
					3/4	19	<b>T2241-0509</b>													
8	5/16	3/4	1/2	-0512	7/8	22	<b>T2240-0512</b>	1.38	35	2.36	60	1.61	41							
10	3/8	9/16	3/8	-0609	11/16		<b>T2240-0609</b>	1.34	34	2.32	59	1.02	26	<b>T2280-0609</b>	2.05	52	3.03	77	2.17	55
					3/4	19	<b>T2241-0609</b>							<b>T2281-0609</b>						
10	3/8	3/4	1/2	-0612	7/8	22	<b>T2240-0612</b>	1.38	35	2.36	60	1.18	30	<b>T2280-0612</b>	2.05	52	3.03	77	2.52	64
10	3/8	7/8	5/8	-0614	1.1/16	27	<b>T2240-0614</b>	1.38	35	2.36	60	1.61	41							
12	1/2	3/4	1/2	-0812	7/8	22	<b>T2240-0812</b>	1.61	41	2.60	66	1.50	38	<b>T2280-0812</b>	2.01	51	2.99	76	2.36	60
12	1/2	7/8	5/8	-0814	1.1/16	27	<b>T2240-0814</b>	1.61	41	2.60	66	1.61	41	<b>T2280-0814</b>	2.17	55	3.15	80	2.76	70
12	1/2	1.1/16	3/4	-0817	1.1/4	32	<b>T2240-0817</b>	1.61	41	2.60	66	1.77	45							
16	5/8	3/4	1/2	-1012	7/8	22	<b>T2240-1012</b>	1.97	50	3.15	80	1.61	41							
16	5/8	7/8	5/8	-1014	1.1/16	27	<b>T2240-1014</b>	1.77	45	2.99	76	1.85	47	<b>T2280-1014</b>	2.01	51	3.23	82	2.76	70
16	5/8	1.1/16	3/4	-1017	1.1/4	32	<b>T2240-1017</b>	1.77	45	2.99	76	1.89	48	<b>T2280-1017</b>	2.01	51	3.23	82	3.78	96
19	3/4	7/8	5/8	-1214	1.1/16	27	<b>T2240-1214</b>	2.17	55	3.35	85	1.89	48							
19	3/4	1.1/16	3/4	-1217	1.1/4	32	<b>T2240-1217</b>	2.32	59	3.50	89	2.24	57	<b>T2280-1217</b>	2.32	59	3.50	89	3.78	96
19	3/4	1.3/16	7/8	-1219	1.3/8		<b>T2240-1219</b>	2.17	55	3.35	85	2.28	58							
19	3/4	1.5/16	1	-1221	1.1/2	38	<b>T2240-1221</b>	2.32	59	3.50	89	2.80	71							
25	1	1.1/16	3/4	-1617	1.1/4	32	<b>T2240-1617</b>	2.17	55	3.39	86	2.32	59							
25	1	1.5/16	1	-1621	1.1/2	38	<b>T2240-1621</b>	2.68	68	3.86	98	2.83	72	<b>T2280-1621</b>	2.95	75	4.17	106	4.49	114
25	1	1.5/8	1.1/4	-1626	2	50	<b>T2240-1626</b>	2.68	68	3.90	99	3.07	78							
31	1.1/4	1.5/8	1.1/4	-2026	2	50	<b>T2240-2026</b>	3.94	100	5.87	149	3.19	81	<b>T2280-2026</b>	3.94	100	5.87	149	5.08	129
38	1.1/2	1.7/8	1.1/2	-2430	2.1/4	57	<b>T2240-2430</b>	4.17	106	6.22	158	4.17	106	<b>T2280-2430</b>	4.17	106	6.22	158	5.55	141
51	2	2.1/2	2	-3240	2.7/8	73	<b>T2240-3240</b>	5.83	148	8.03	204	5.20	132	<b>T2280-3240</b>	5.83	148	8.03	204	8.74	222

**NOTE:** Hose Compatibility for the **T2000** series can be found on page 187.

## T2000 SERIES ONE-PIECE CRIMP COUPLINGS

### JIS - BSPP T2220

JAPANESE INDUSTRIAL  
STANDARD (JIS)  
BSPP THREAD FORM  
60° CONVEX SEAT

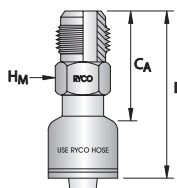

HOSE SIZE		THRD SIZE	DASH SIZE	MALE HEX		BSPP MALE 60° CONVEX SEAT (JIS)					
DN	inch	inch		HM SPANNER		PART NO		CA		L	
	inch	inch		inch	mm	inch	mm	inch	mm	inch	mm
6	1/4	1/4	-0404		17	<b>T2220-0404</b>	1.30	33	2.28	58	
10	3/8	3/8	-0606	3/4	19	<b>T2220-0606</b>	1.42	36	2.40	61	
12	1/2	1/2	-0808	7/8	22	<b>T2220-0808</b>	1.61	41	2.60	66	

### JIS - BSPP T2122

JAPANESE INDUSTRIAL  
STANDARD (JIS)  
BSPP THREAD FORM  
60° CONCAVE SEAT

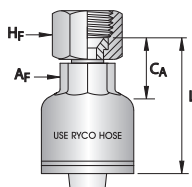

HOSE SIZE		THRD SIZE	DASH SIZE	BACK UP AF		FEMALE HEX		BSPP FEMALE 60° CONCAVE SEAT (JIS)					
DN	inch	inch		AF-SPANNER		HF-SPANNER		PART NO		CA		L	
	inch	inch		inch	mm	inch	mm	inch	mm	inch	mm	inch	mm
6	1/4	1/4	-0404		12	3/4	19	<b>T2122-0404</b>	0.79	20	1.77	45	
10	3/8	3/8	-0606	5/8	16	7/8	22	<b>T2122-0606</b>	0.98	25	1.97	50	
10	3/8	1/2	-0608	5/8	16	1.1/16	27	<b>T2122-0608</b>	1.06	27	2.05	52	
12	1/2	1/2	-0808	3/4	19	1.1/16	27	<b>T2122-0808</b>	0.98	25	1.97	50	
16	5/8	3/4	-1012	7/8	22		36	<b>T2122-1012</b>	1.18	30	2.40	61	
19	3/4	3/4	-1212	1.1/16	27		36	<b>T2122-1212</b>	1.22	31	2.40	61	
25	1	1	-1616	1.1/4	32	1.5/8	41	<b>T2122-1616</b>	1.38	35	2.60	66	

**NOTE:** Hose Compatibility for the **T2000** series can be found on page 187.

# COUPLINGS

## T2000 SERIES ONE-PIECE CRIMP COUPLINGS

<b>JIS - METRIC</b>	<b>T2680</b>	<b>T2682</b>
---------------------	--------------	--------------

**JAPANESE INDUSTRIAL STANDARD (JIS)  
METRIC THREAD FORM  
60° CONCAVE SEAT**

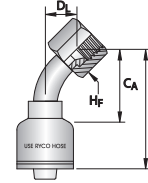
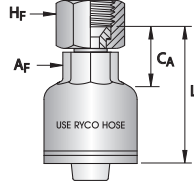

HOSE SIZE	THRD SIZE	DASH SIZE	BACK UP Af	FEMALE HEX	METRIC FEMALE 60° CONCAVE SEAT (JIS)				METRIC FEMALE 60° CONCAVE SEAT (JIS) 45° TUBE BEND												
					Af-SPANNER		Hf-SPANNER		PART NO		CA		L		PART NO		CA		L		DL
DN	inch	mm		inch	mm	inch	mm	inch	mm	inch	mm	inch	mm	inch	mm	inch	mm	inch	mm	inch	mm
6	1/4	14x1,5	-0414		12	3/4	19	<b>T2680-0414</b>	0.87	22	1.89	48	<b>T2682-0414</b>	1.30	33	2.28	58	0.59	15		
6	1/4	18x1,5	-0418		12	7/8	22	<b>T2680-0418</b>	0.94	24	1.93	49									
8	5/16	16x1,5	-0516		14	7/8	22	<b>T2680-0516</b>	0.91	23	1.89	48									
10	3/8	16x1,5	-0616	5/8	16	7/8	22	<b>T2680-0616</b>	0.98	25	1.97	50									
10	3/8	18x1,5	-0618	5/8	16	7/8	22	<b>T2680-0618</b>	1.02	26	2.01	51	<b>T2682-0618</b>	1.54	39	2.52	64	0.75	19		
10	3/8		-0620	5/8	16	1.1/16	27	<b>T2680-0620</b>	1.06	27	2.05	52									
10	3/8	22x1,5	-0622	5/8	16	1.1/16	27	<b>T2680-0622</b>	1.10	28	2.09	53									
12	1/2	22x1,5	-0822	3/4	19	1.1/16	27	<b>T2680-0822</b>	1.06	27	2.05	52	<b>T2682-0822</b>	1.85	47	2.83	72	0.83	21		
12	1/2	24x1,5	-0824	3/4	19	1.3/16	30	<b>T2680-0824</b>	1.14	29	2.13	54									
16	5/8	24x1,5	-1024	7/8	22	1.3/16	30	<b>T2680-1024</b>	1.18	30	2.40	61	<b>T2682-1024</b>	2.13	54	3.35	85	0.94	24		
16	5/8	30x1,5	-1030	7/8	22		36	<b>T2680-1030</b>	1.38	35	2.60	66									
19	3/4	24x1,5	-1224	1.1/16	27	1.3/16	30	<b>T2680-1224</b>	1.22	31	2.40	61									
19	3/4	30x1,5	-1230	1.1/16	27		36	<b>T2680-1230</b>	1.50	38	2.68	68	<b>T2682-1230</b>	2.64	67	3.82	97	1.10	28		
19	3/4	33x1,5	-1233	1.1/16	27	1.1/2	38	<b>T2680-1233</b>	1.50	38	2.68	68									
25	1	33x1,5	-1633	1.1/4	32	1.1/2	38	<b>T2680-1633</b>	1.38	35	2.60	66	<b>T2682-1633</b>	3.31	84	4.53	115	1.26	32		
31	1.1/4	36x1,5	-2036	1.5/8	41		46	<b>T2680-2036</b>	1.50	38	3.43	87									
31	1.1/4	42x1,5	-2042	1.5/8	41	2	50	<b>T2680-2042</b>	1.69	43	3.62	92									

<b>JIS - METRIC</b>	<b>T2683</b>
---------------------	--------------

**JAPANESE INDUSTRIAL STANDARD (JIS)  
METRIC THREAD FORM  
60° CONCAVE SEAT**

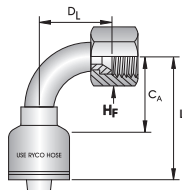

HOSE SIZE	THRD SIZE	DASH SIZE	METRIC FEMALE 60° CONCAVE SEAT (JIS) 90° TUBE BEND							
			PART NO		CA		L		DL	
DN	inch	inch	inch	mm	inch	mm	inch	mm	inch	mm
6	1/4	14	-0414	<b>T2683-0414</b>	1.06	27	2.05	52	1.18	30
10	3/8	18	-0618	<b>T2683-0618</b>	1.38	35	2.36	60	1.30	33
12	1/2	22	-0822	<b>T2683-0822</b>	1.50	38	2.48	63	1.65	42
16	5/8	24	-1024	<b>T2683-1024</b>	1.77	45	2.99	76	1.89	48
19	3/4	30	-1230	<b>T2683-1230</b>	2.32	59	3.50	89	2.20	56
25	1	33	-1633	<b>T2683-1633</b>	2.83	72	4.06	103	2.76	70



## T2000 SERIES ONE-PIECE CRIMP COUPLINGS

<b>JOINER</b>	<b>T2900</b>
---------------	--------------

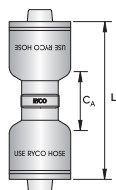

HOSE SIZE		DASH SIZE	JOINER				
DN	inch	inch	PART NO	CA		L	
				inch	mm	inch	mm
6	1/4	-0404	<b>T2900-0404</b>	0.98	25	1.97	50
8	5/16	-0505	<b>T2900-0505</b>	0.98	25	1.97	50
10	3/8	-0606	<b>T2900-0606</b>	1.10	28	2.09	53
12	1/2	-0808	<b>T2900-0808</b>	1.18	30	2.13	54
16	5/8	-1010	<b>T2900-1010</b>	0.94	24	2.17	55
19	3/4	-1212	<b>T2900-1212</b>	1.26	32	2.44	62
25	1	-1616	<b>T2900-1616</b>	1.26	32	2.44	62
31	1.1/4	-2020	<b>T2900-2020</b>	1.57	40	3.50	89
38	1.1/2	-2424	<b>T2900-2424</b>	0.98	25	3.03	77
51	2	-3232	<b>T2900-3232</b>	1.02	26	3.23	82
63	2.1/2	-4040	<b>T2900-4040</b>	0.98	25	4.02	102
76	3	-4848	<b>T2900-4848</b>	1.02	26	4.02	102

INTRODUCTION

HOSE

COUPLINGS

ADAPTORS

TECHNICAL

**NOTE:** Hose Compatibility for the **T2000** series can be found on page 187.

# COUPLINGS

## T2000 SERIES ONE-PIECE CRIMP COUPLINGS

METRIC - DKL

T2650

DKL  
METRIC (LIGHT)  
24° CONE

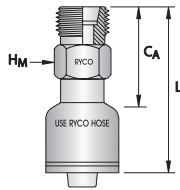

HOSE SIZE	THRD SIZE	TUBE SIZE	DASH SIZE	MALE HEX	DKL MALE 24° CONE						
					HM-SPANNER		PART NO	CA		L	
DN	inch	mm	mm		inch	mm		inch	mm	inch	mm
6	1/4	12x1,5	6	-0412		14	<b>T2650-0412</b>	1.06	27	2.09	53
6	1/4	14x1,5	8	-0414		17	<b>T2650-0414</b>	1.06	27	2.09	53
6	1/4	16x1,5	10	-0416		17	<b>T2650-0416</b>	1.14	29	2.13	54
6	1/4	18x1,5	12	-0418	3/4	19	<b>T2650-0418</b>	1.18	30	2.17	55
8	5/16	16x1,5	10	-0516		17	<b>T2650-0516</b>	1.14	29	2.13	54
8	5/16	18x1,5	12	-0518	3/4	19	<b>T2650-0518</b>	1.18	30	2.17	55
10	3/8	16x1,5	10	-0616		17	<b>T2650-0616</b>	1.22	31	2.20	56
10	3/8	18x1,5	12	-0618	3/4	19	<b>T2650-0618</b>	1.26	32	2.24	57
10	3/8	22x1,5	15	-0622	15/16	24	<b>T2650-0622</b>	1.38	35	2.36	60
12	1/2	18x1,5	12	-0818	3/4	19	<b>T2650-0818</b>	1.34	34	2.32	59
12	1/2	22x1,5	15	-0822	7/8	22	<b>T2650-0822</b>	1.38	35	2.36	60
12	1/2	26x1,5	18	-0826	1.3/16	30	<b>T2650-0826</b>	1.42	36	2.40	61
16	5/8	26x1,5	18	-1026	1.3/16	30	<b>T2650-1026</b>	1.34	34	2.52	64
16	5/8	30x2,0	22	-1030	1.1/4	32	<b>T2650-1030</b>	1.50	38	2.68	68
19	3/4	26x1,5	18	-1226	1.3/16	30	<b>T2650-1226</b>	1.50	38	2.64	67
19	3/4	30x2,0	22	-1230	1.1/4	32	<b>T2650-1230</b>	1.65	42	2.80	71
25	1	36x2,0	28	-1636	1.5/8	41	<b>T2650-1636</b>	1.73	44	2.95	75
31	1.1/4	45x2,0	35	-2045		46	<b>T2650-2045</b>	2.01	51	3.94	100
38	1.1/2	52x2,0	42	-2452	2.3/16	55	<b>T2650-2452</b>	1.89	48	3.90	99

**NOTE:** Hose Compatibility for the T2000 series can be found on page 187.

## T2000 SERIES ONE-PIECE CRIMP COUPLINGS

<b>METRIC - DKL</b>	<b>T2600</b>	<b>T2660</b>
---------------------	--------------	--------------

**DKL**  
**METRIC (LIGHT)**  
**RYCO DKL FEMALE SWIVELS**  
**UP TO M26 SIZE HAVE MULTISEAL DKL 24° AND**  
**DKM 60° CONE. M30 AND OVER HAVE DKL 24°**  
**CONE ONLY.**

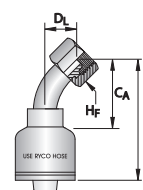
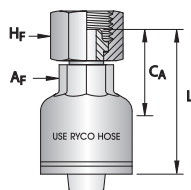

HOSE SIZE	THRD SIZE	TUBE SIZE	DASH SIZE	BACK UP Af		FEMALE HEX		DKL FEMALE 24°/60° CONE				DKL FEMALE 24°/60° CONE 45° TUBE BEND								
				inch	mm	inch	mm	PART NO	CA	L	PART NO	CA	L	DL						
6	1/4	12x1,5	6	-0412		12		14	<b>T2600-0412</b>	1.06	27	2.05	52	<b>T2660-0412</b>	1.42	36	2.40	61	0.71	18
6	1/4	14x1,5	8	-0414		12		17	<b>T2600-0414</b>	1.06	27	2.05	52	<b>T2660-0414</b>	1.42	36	2.40	61	0.67	17
8	5/16	16x1,5	10	-0516			3/4	19						<b>T2660-0516</b>	1.77	45	2.76	70	0.79	20
6	1/4	16x1,5	10	-0416		12	3/4	19	<b>T2600-0416</b>	1.10	28	2.09	53							
8	5/16	16x1,5	10	-0516		14	3/4	19	<b>T2600-0516</b>	1.10	28	2.09	53							
8	5/16	18x1,5	12	-0518		14	7/8	22	<b>T2600-0518</b>	1.18	30	2.17	55							
10	3/8	14x1,5	8	-0614	5/8	16		17	<b>T2600-0614</b>	1.06	27	2.05	52							
10	3/8	16x1,5	10	-0616	5/8	16	3/4	19	<b>T2600-0616</b>	1.14	29	2.13	54	<b>T2660-0616</b>	1.77	45	2.76	70	0.79	20
10	3/8	18x1,5	12	-0618	5/8	16	7/8	22	<b>T2600-0618</b>	1.18	30	2.17	55	<b>T2660-0618</b>	1.77	45	2.76	70	0.79	20
10	3/8	22x1,5	15	-0622	5/8	16	1.1/16	27	<b>T2600-0622</b>	1.26	32	2.24	57							
12	1/2	18x1,5	12	-0818	3/4	19	7/8	22	<b>T2600-0818</b>	1.14	29	2.13	54							
12	1/2	22x1,5	15	-0822	3/4	19	1.1/16	27	<b>T2600-0822</b>	1.22	31	2.20	56	<b>T2660-0822</b>	1.97	50	2.95	75	0.87	22
12	1/2	26x1,5	18	-0826	3/4	19	1.1/4	32	<b>T2600-0826</b>	1.26	32	2.24	57	<b>T2660-0826</b>	1.97	50	2.95	75	0.87	22
16	5/8	26x1,5	18	-1026	7/8	22	1.1/4	32	<b>T2600-1026</b>	1.34	34	2.56	65	<b>T2660-1026</b>	2.36	60	3.58	91	1.10	28
19	3/4	26x1,5	18	-1226	1.1/16	27	1.1/4	32	<b>T2600-1226</b>	1.54	39	2.68	68							
19	3/4	30x2,0	22	-1230	1.1/16	27		36	<b>T2600-1230</b>	1.50	38	2.68	68	<b>T2660-1230</b>	2.87	73	4.06	103	1.26	32
25	1	36x2,0	28	-1636	1.1/4	32	1.5/8	41	<b>T2600-1636</b>	1.69	43	2.91	74	<b>T2660-1636</b>	3.23	82	4.45	113	1.65	42
31	1.1/4	45x2,0	35	-2045	1.5/8	41	2	50	<b>T2600-2045</b>	1.85	47	3.82	97							

**NOTE:** Hose Compatibility for the **T2000** series can be found on page 187.

# COUPLINGS

## T2000 SERIES ONE-PIECE CRIMP COUPLINGS

### METRIC - DKL

### T2670

DKL  
METRIC (LIGHT)  
RYCO DKL FEMALE SWIVELS  
UP TO M26 SIZE HAVE MULTISEAL DKL  
24° AND DKM 60° CONE. M30 AND OVER  
HAVE DKL 24° CONE ONLY.

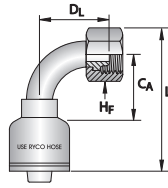

HOSE SIZE					THRD SIZE		TUBE SIZE		DASH SIZE		FEMALE HEX		DKL FEMALE 24°/60° CONE 90° TUBE BEND			
DN	inch	mm	mm		HF-SPANNER		PART NO		C_A		L		D_L			
					inch	mm			inch	mm	inch	mm	inch	mm		
6	1/4	12x1,5	6	-0412		14	<b>T2670-0412</b>	1.06	27	2.05	52	1.22	31			
6	1/4	14x1,5	8	-0414		17	<b>T2670-0414</b>	1.06	27	2.05	52	1.22	31			
6	1/4	16x1,5	10	-0416	3/4	19	<b>T2670-0416</b>	1.06	27	2.05	52	1.26	32			
10	3/8	14x1,5	8	-0614		17	<b>T2670-0614</b>	1.38	35	2.36	60	1.38	35			
10	3/8	16x1,5	10	-0616	3/4	19	<b>T2670-0616</b>	1.38	35	2.36	60	1.38	35			
10	3/8	18x1,5	12	-0618	7/8	22	<b>T2670-0618</b>	1.38	35	2.36	60	1.38	35			
10	3/8	22x1,5	15	-0622	1.1/16	27	<b>T2670-0622</b>	1.38	35	2.36	60	1.46	37			
12	1/2	22x1,5	15	-0822	1.1/16	27	<b>T2670-0822</b>	1.57	40	2.56	65	1.73	44			
12	1/2	26x1,5	18	-0826	1.1/4	32	<b>T2670-0826</b>	1.50	38	2.48	63	1.97	50			
16	5/8	26x1,5	18	-1026	1.1/4	32	<b>T2670-1026</b>	1.77	45	2.99	76	2.09	53			
19	3/4	30x2,0	22	-1230		36	<b>T2670-1230</b>	2.32	59	3.50	89	2.52	64			
25	1	36x2,0	28	-1636	1.5/8	41	<b>T2670-1636</b>	2.83	72	4.06	103	2.87	73			

### METRIC - DKM

### T2610

DKM  
60° BALL SEAT

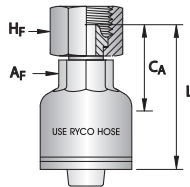

HOSE SIZE					THRD SIZE		TUBE SIZE		DASH SIZE		BACK UP A_F		FEMALE HEX		DKL FEMALE 60° BALL SEAT			
DN	inch	mm	mm		A_F-SPANNER		H_F-SPANNER		PART NO		C_A		L					
					inch	mm	inch	mm			inch	mm	inch	mm				
10	3/8	16x1,5	10	-0616	5/8	16	3/4	19	<b>T2610-0616</b>	1.14	29	2.13	54					
19	3/4	30x1,5	22	-1230	1.1/16	27		36	<b>T2610-1230</b>	1.22	31	2.40	61					
31	1.1/4	52x2,0	42	-2052	1.5/8	41	2.3/8	60	<b>T2610-2052</b>	1.77	45	3.70	94					
38	1.1/2	52x2,0	42	-2452	2	50	2.3/8	60	<b>T2610-2452</b>	1.85	47	3.90	99					

**NOTE:** Hose Compatibility for the **T2000** series can be found on page 187.

## T2000 SERIES ONE-PIECE CRIMP COUPLINGS

<b>METRIC - DKOL</b>	<b>T2501</b>	<b>T2510</b>
----------------------	--------------	--------------

**DKOL  
METRIC O RING (LIGHT)  
24° CONE**

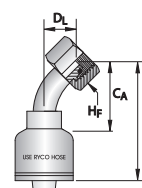
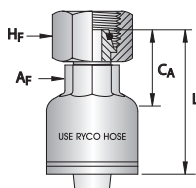

HOSE SIZE	THRD SIZE	TUBE SIZE	DASH SIZE	BACK UP AF		FEMALE HEX		DKOL FEMALE 24° CONE				DKOL FEMALE 24° CONE 45° TUBE BEND								
				inch	mm	inch	mm	PART NO	CA	L	PART NO	CA	L	DL						
DN	inch	mm	mm		AF-SPANNER	HF-SPANNER			inch	mm	inch	mm	inch	mm	inch	mm	inch	mm		
5	3/16	12x1,5	6	-0312		12		14	<b>T2501-0312</b>	0.83	21	1.61	41							
6	1/4	12x1,5	6	-0412		12		14	<b>T2501-0412</b>	1.02	26	2.05	52	<b>T2510-0412</b>	1.57	40	2.56	65	0.71	18
6	1/4	14x1,5	8	-0414		12		17	<b>T2501-0414</b>	1.02	26	2.05	52	<b>T2510-0414</b>	1.42	36	2.40	61	0.67	17
6	1/4	16x1,5	10	-0416		12	3/4	19	<b>T2501-0416</b>	1.10	28	2.13	54	<b>T2510-0416</b>	1.42	36	2.40	61	0.67	17
6	1/4	18x1,5	10	-0418			7/8	22						<b>T2510-0418</b>	1.46	37	2.44	62	0.79	20
8	5/16	14x1,5	8	-0514		14		17	<b>T2501-0514</b>	1.06	27	2.05	52							
8	5/16	16x1,5	10	-0516		14	3/4	19	<b>T2501-0516</b>	1.14	29	2.13	54	<b>T2510-0516</b>	1.77	45	2.76	70	0.79	20
8	5/16	18x1,5	12	-0518		14	7/8	22	<b>T2501-0518</b>	1.14	29	2.17	55	<b>T2510-0518</b>	1.77	45	2.76	70	0.79	20
10	3/8	12x1,5	6	-0612	5/8	16		14	<b>T2501-0612</b>	1.06	27	2.05	52	<b>T2510-0612</b>	1.77	45	2.76	70	0.71	18
10	3/8	14x1,5	8	-0614	5/8	16		17	<b>T2501-0614</b>	1.06	27	2.05	52							
10	3/8	16x1,5	10	-0616	5/8	16	3/4	19	<b>T2501-0616</b>	1.14	29	2.13	54	<b>T2510-0616</b>	1.77	45	2.76	70	0.75	19
10	3/8	18x1,5	12	-0618	5/8	16	7/8	22	<b>T2501-0618</b>	1.18	30	2.17	55	<b>T2510-0618</b>	1.77	45	2.76	70	0.79	20
10	3/8	22x1,5	15	-0622	5/8	16	1.1/16	27	<b>T2501-0622</b>	1.26	32	2.24	57	<b>T2510-0622</b>						
12	1/2	18x1,5	12	-0818	3/4	19	7/8	22	<b>T2501-0818</b>	1.14	29	2.13	54							
12	1/2	22x1,5	15	-0822	3/4	19	1.1/16	27	<b>T2501-0822</b>	1.26	32	2.24	57	<b>T2510-0822</b>	2.05	52	3.03	77	0.87	22
12	1/2	26x1,5	18	-0826	3/4	19	1.1/4	32	<b>T2501-0826</b>	1.30	33	2.28	58	<b>T2510-0826</b>	2.09	53	3.07	78	0.94	24
16	5/8	26x1,5	18	-1026	7/8	22	1.1/4	32	<b>T2501-1026</b>	1.34	34	2.56	65	<b>T2510-1026</b>	2.28	58	3.50	89	1.10	28
16	5/8	30x2,0	22	-1030	7/8	22		36	<b>T2501-1030</b>	1.42	36	2.60	66	<b>T2510-1030</b>	2.36	60	3.54	90	1.14	29
19	3/4	26x1,5	18	-1226	1.1/16	27	1.1/4	32	<b>T2501-1226</b>	1.54	39	2.68	68							
19	3/4	30x2,0	22	-1230	1.1/16	27		36	<b>T2501-1230</b>	1.50	38	2.68	68	<b>T2510-1230</b>	2.91	74	4.09	104	1.22	31
25	1	36x2,0	28	-1636	1.1/4	32	1.5/8	41	<b>T2501-1636</b>	1.69	43	2.91	74	<b>T2510-1636</b>	3.62	92	4.84	123	1.81	46
31	1.1/4	45x2,0	35	-2045	1.5/8	41	2	50	<b>T2501-2045</b>	1.85	47	3.82	97	<b>T2510-2045</b>	3.98	101	5.91	150	1.57	40
38	1.1/2	52x2,0	42	-2452	2	50	2.3/8	60	<b>T2501-2452</b>	1.97	50	4.02	102	<b>T2510-2452</b>	4.65	118	6.65	169	1.93	49

**NOTE:** Hose Compatibility for the **T2000** series can be found on page 187.

INTRODUCTION

HOSE

COUPLINGS

ADAPTORS

TECHNICAL



# COUPLINGS

## T2000 SERIES ONE-PIECE CRIMP COUPLINGS

**METRIC - DKOL**

**T2520**

**DKOL  
METRIC O RING (LIGHT)  
24° CONE**

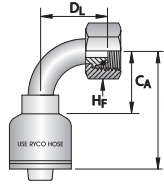

HOSE SIZE		THRD SIZE	TUBE SIZE	DASH SIZE	FEMALE HEX		DKOL FEMALE 24° CONE 90° TUBE BEND						
DN	inch	mm	mm		HF-SPANNER		PART NO	CA		L		DL	
					inch	mm		inch	mm	inch	mm	inch	mm
	1/4	12x1,5	6	-0412		14	<b>T2520-0412</b>	1.54	39	2.52	64	1.34	34
6	1/4	14x1,5	8	-0414		17	<b>T2520-0414</b>	1.30	33	2.28	58	1.22	31
6	1/4	16x1,5	10	-0416	3/4	19	<b>T2520-0416</b>	1.06	27	2.05	52	1.22	31
6	1/4	18x1,5	12	-0418	7/8	22	<b>T2520-0418</b>	1.30	33	2.28	58	1.34	34
8	5/16	16x1,5	10	-0516	3/4	19	<b>T2520-0516</b>	1.38	35	2.36	60	1.38	35
8	5/16	18x1,5	12	-0518	7/8	22	<b>T2520-0518</b>	1.38	35	2.36	60	1.38	35
10	3/8	16x1,5	10	-0616	3/4	19	<b>T2520-0616</b>	1.38	35	2.36	60	1.42	36
10	3/8	18x1,5	12	-0618	7/8	22	<b>T2520-0618</b>	1.38	35	2.36	60	1.38	35
10	3/8	22x1,5	15	-0622	1.1/16	27	<b>T2520-0622</b>	1.57	40	2.56	65	1.73	44
12	1/2	22x1,5	15	-0822	1.1/16	27	<b>T2520-0822</b>	1.61	41	2.60	66	1.73	44
12	1/2	26x1,5	18	-0826	1.1/4	32	<b>T2520-0826</b>	1.61	41	2.60	66	1.89	48
16	5/8	26x1,5	18	-1026	1.1/4	32	<b>T2520-1026</b>	1.77	45	2.99	76	2.13	54
19	3/4	30x2,0	22	-1230		36	<b>T2520-1230</b>	2.32	59	3.50	89	2.56	65
25	1	36x2,0	28	-1636	1.5/8	41	<b>T2520-1636</b>	2.72	69	3.94	100	3.11	79
31	1.1/4	45x2,0	35	-2045	2	50	<b>T2520-2045</b>	3.94	100	5.87	149	2.99	76
38	1.1/2	52x2,0	42	-2452	2.3/8	60	<b>T2520-2452</b>	4.17	106	6.22	158	4.02	102

**NOTE:** Hose Compatibility for the **T2000** series can be found on page 187.

## T2000 SERIES ONE-PIECE CRIMP COUPLINGS

<b>METRIC - DKS</b>	<b>T2630</b>
---------------------	--------------

**DKS  
METRIC (HEAVY)  
24° CONE**

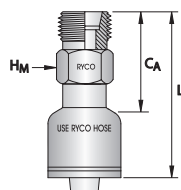

DN	HOSE SIZE		TUBE SIZE		DASH SIZE		MALE HEX		DKS MALE 24° CONE			
	inch	mm	mm		inch	mm	HM-SPANNER	PART NO	CA		L	
6	1/4	14x1,5	6	-0414		17		<b>T2630-0414</b>	1.18	30	2.17	55
6	1/4	16x1,5	8	-0416		17		<b>T2630-0416</b>	1.18	30	2.17	55
6	1/4	18x1,5	10	-0418	3/4	19		<b>T2630-0418</b>	1.22	31	2.20	56
6	1/4	20x1,5	12	-0420	7/8	22		<b>T2630-0420</b>	1.26	32	2.24	57
10	3/8	22x1,5	14	-0422	15/16	24		<b>T2630-0422</b>	1.38	35	2.36	60
6	1/4	22x1,5	14	-0520	15/16	24		<b>T2630-0520</b>	1.26	32	2.24	57
8	5/16	20x1,5	12	-0618	7/8	22		<b>T2630-0618</b>	1.30	33	2.28	58
10	3/8	18x1,5	10	-0620	3/4	19		<b>T2630-0620</b>	1.34	34	2.32	59
10	3/8	20x1,5	12	-0622	7/8	22		<b>T2630-0622</b>	1.46	37	2.44	62
12	1/2	24x1,5	16	-0824	1.1/16	27		<b>T2630-0824</b>	1.50	38	2.48	63
12	1/2	30x2,0	20	-0830	1.1/4	32		<b>T2630-0830</b>	1.65	42	2.64	67
16	5/8	30x2,0	20	-1030	1.1/4	32		<b>T2630-1030</b>	1.57	40	2.76	70
19	3/4	30x2,0	20	-1230	1.1/4	32		<b>T2630-1230</b>	1.73	44	2.87	73
19	3/4	36x2,0	25	-1236	1.5/8	41		<b>T2630-1236</b>	1.89	48	3.07	78
25	1	36x2,0	25	-1636	1.5/8	41		<b>T2630-1636</b>	1.89	48	3.11	79
25	1	42x2,0	30	-1642		46		<b>T2630-1642</b>	2.01	51	3.23	82
31	1.1/4	42x2,0	30	-2042		46		<b>T2630-2042</b>	2.17	55	4.09	104
31	1.1/4	52x2,0	38	-2052	2.3/16	55		<b>T2630-2052</b>	2.32	59	4.25	108
38	1.1/2	52x2,0	38	-2452	2.3/16	55		<b>T2630-2452</b>	2.13	54	4.13	105

INTRODUCTION

HOSE

COUPLINGS

ADAPTORS

TECHNICAL

# COUPLINGS

## T2000 SERIES ONE-PIECE CRIMP COUPLINGS

METRIC - DKOS

T2711

DKOS  
METRIC O RING (HEAVY)  
24° CONE

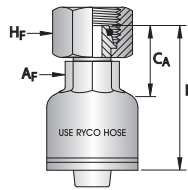

HOSE SIZE		THRD SIZE	TUBE SIZE	DASH SIZE	BACK UP Af		FEMALE HEX		DKOS FEMALE 24° CONE				
DN	inch	mm	mm		Af-SPANNER		Hf-SPANNER		PART NO	CA		L	
					inch	mm	inch	mm		inch	mm	inch	mm
6	1/4	14x1,5	6	-0414		12		17	<b>T2711-0414</b>	0.98	25	1.97	50
6	1/4	16x1,5	8	-0416		12	3/4	19	<b>T2711-0416</b>	1.06	27	2.09	53
6	1/4	18x1,5	10	-0418		12	7/8	22	<b>T2711-0418</b>	1.18	30	2.17	55
8	5/16	18x1,5	10	-0518		14			<b>T2711-0518</b>	1.22	31	2.20	56
8	5/16	20x1,5	12	-0520		14	15/16	24	<b>T2711-0520</b>	1.22	31	2.20	56
10	3/8	16x1,5	8	-0616	5/8	16			<b>T2711-0616</b>	1.10	28	2.09	53
10	3/8	18x1,5	10	-0618	5/8	16	7/8	22	<b>T2711-0618</b>	1.22	31	2.20	56
10	3/8	20x1,5	12	-0620	5/8	16	15/16	24	<b>T2711-0620</b>	1.22	31	2.20	56
10	3/8	22x1,5	14	-0622	5/8	16	1.1/16	27	<b>T2711-0622</b>	1.30	33	2.28	58
10	3/8	24x1,5	16	-0624	5/8	16	1.3/16	30	<b>T2711-0624</b>	1.30	33	2.28	58
12	1/2	20x1,5	12	-0820	3/4	19	15/16	24	<b>T2711-0820</b>	1.22	31	2.20	56
12	1/2	22x1,5	14	-0822	3/4	19	1.1/16	27	<b>T2711-0822</b>	1.30	33	2.28	58
12	1/2	24x1,5	16	-0824	3/4	19	1.3/16	30	<b>T2711-0824</b>	1.30	33	2.28	58
16	5/8	30x2,0	20	-1030	7/8	22		36	<b>T2711-1030</b>	1.57	40	2.80	71
19	3/4	30x2,0	20	-1230	1.1/16	27		36	<b>T2711-1230</b>	1.65	42	2.80	71
19	3/4	36x2,0	25	-1236	1.1/16	27		46	<b>T2711-1236</b>	1.81	46	2.99	76
25	1	36x2,0	25	-1636	1.1/4	32		46	<b>T2711-1636</b>	1.81	46	2.99	76
25	1	42x2,0	30	-1642	1.1/4	32	2	50	<b>T2711-1642</b>	1.81	46	3.03	77
31	1.1/4	42x2,0	30	-2042	1.5/8	41	2	50	<b>T2711-2042</b>	2.01	51	3.94	100
31	1.1/4	52x2,0	38	-2452	1.5/8	41	2.3/8	60	<b>T2711-2052</b>	2.24	57	4.21	107
38	1.1/2	52x2,0	38	-2052	2	50	2.3/8	60	<b>T2711-2452</b>	2.28	58	4.33	110

**NOTE:** Hose Compatibility for the **T2000** series can be found on page 187.

## T2000 SERIES ONE-PIECE CRIMP COUPLINGS

<b>METRIC - DKOS</b>	<b>T2720</b>
----------------------	--------------

**DKOS**  
**METRIC O RING (HEAVY)**  
**24° CONE**

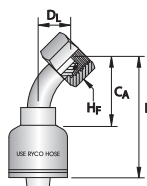

DN	HOSE SIZE		TUBE SIZE	DASH SIZE	FEMALE HEX		PART NO	CA		L		DL	
	inch	mm			inch	mm		inch	mm	inch	mm	inch	mm
6	1/4	14x1,5	6	-0414		17	<b>T2720-0414</b>	1.46	37	2.44	62	0.63	16
6	1/4	16x1,5	8	-0416	3/4	19	<b>T2720-0416</b>	1.42	36	2.40	61	0.67	17
6	1/4	18x1,5	10	-0418	7/8	22	<b>T2720-0418</b>	1.42	36	2.40	61	0.67	17
8	5/16	18x1,5	10	-0518	7/8	22	<b>T2720-0518</b>	1.81	46	2.80	71	0.67	17
8	5/16	20x1,5	12	-0520	15/16	24	<b>T2720-0520</b>	1.81	46	2.80	71	0.67	17
10	3/8	16x1,5	8	-0616			<b>T2720-0616</b>	1.77	45	2.76	70	0.67	17
10	3/8	18x1,5	10	-0618	7/8	22	<b>T2720-0618</b>	1.77	45	2.76	70	0.67	17
10	3/8	20x1,5	12	-0620	15/16	24	<b>T2720-0620</b>	1.81	46	2.80	71	0.79	20
10	3/8	22x1,5	14	-0622	1.1/16	27	<b>T2720-0622</b>	1.81	46	2.80	71	0.79	20
10	3/8	36x1,5	25	-0636			<b>T2720-0636</b>	2.36	60	3.35	85	1.38	35
12	1/2	22x1,5	14	-0822	1.1/16	27	<b>T2720-0822</b>	2.09	53	3.07	78	0.94	24
12	1/2	24x1,5	16	-0824	1.3/16	30	<b>T2720-0824</b>	2.09	53	3.07	78	0.94	24
16	5/8	30x2,0	20	-1030		36	<b>T2720-1030</b>	2.40	61	3.62	92	1.22	31
19	3/4	30x2,0	20	-1230		36	<b>T2720-1230</b>	2.91	74	4.09	104	1.38	35
19	3/4	36x2,0	25	-1236		46	<b>T2720-1236</b>	2.99	76	4.17	106	1.38	35
25	1	36x2,0	25	-1636		46	<b>T2720-1636</b>	3.54	90	4.76	121	1.38	35
25	1	42x2,0	30	-1642	2	50	<b>T2720-1642</b>	3.43	87	4.65	118	1.46	37
31	1.1/4	52x2,0	38	-2052	2.3/8	60	<b>T2720-2052</b>	4.17	106	6.10	155	1.89	48

**NOTE:** Hose Compatibility for the **T2000** series can be found on page 187.

INTRODUCTION  
 HOSE  
**COUPLINGS**  
 ADAPTORS  
 TECHNICAL

# COUPLINGS

## T2000 SERIES ONE-PIECE CRIMP COUPLINGS

METRIC - DKOS

T2730

DKOS  
METRIC O RING (HEAVY)  
24° CONE

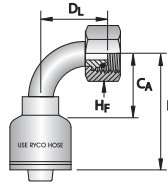

HOSE SIZE					THRD SIZE		TUBE SIZE		DASH SIZE		FEMALE HEX		DKOS FEMALE 24° CONE 90° TUBE BEND			
DN	inch	mm	mm		HF-SPANNER		PART NO		CA		L		DL			
					inch	mm			inch	mm	inch	mm	inch	mm		
6	1/4	14x1,5	6	-0414		17	<b>T2730-0414</b>	1.30	33	2.28	58	1.10	28			
6	1/4	16x1,5	8	-0416	3/4	19	<b>T2730-0416</b>	1.06	27	2.05	52	1.22	31			
6	1/4	18x1,5	10	-0418	7/8	22	<b>T2730-0418</b>	1.30	33	2.28	58	1.26	32			
8	5/16	20x1,5	12	-0520	15/16	24	<b>T2730-0520</b>	1.38	35	2.36	60	1.46	37			
10	3/8	16x1,5	8	-0616	3/4	19	<b>T2730-0616</b>	1.38	35	2.36	60	1.26	32			
10	3/8	18x1,5	10	-0618	7/8	22	<b>T2730-0618</b>	1.06	27	2.05	52	1.18	30			
10	3/8	20x1,5	12	-0620	15/16	24	<b>T2730-0620</b>	1.42	36	2.40	61	1.42	36			
10	3/8	22x1,5	14	-0622	1.1/16	27	<b>T2730-0622</b>	1.42	36	2.40	61	1.42	36			
12	1/2	22x1,5	14	-0822	1.1/16	27	<b>T2730-0822</b>	1.61	41	2.60	66	1.89	48			
12	1/2	24x1,5	16	-0824	1.3/16	30	<b>T2730-0824</b>	1.61	41	2.60	66	1.89	48			
16	5/8	30x2,0	20	-1030		36	<b>T2730-1030</b>	1.77	45	2.99	76	2.28	58			
19	3/4	30x2,0	20	-1230		36	<b>T2730-1230</b>	2.32	59	3.50	89	2.68	68			
19	3/4	36x2,0	25	-1236		46	<b>T2730-1236</b>	2.32	59	3.50	89	2.68	68			
25	1	36x2,0	25	-1636		46	<b>T2730-1636</b>	2.72	69	3.94	100	3.03	77			
25	1	42x2,0	30	-1642	2	50	<b>T2730-1642</b>	2.72	69	3.94	100	3.03	77			
31	1.1/4	52x2,0	38	-2052	2.3/8	60	<b>T2730-2052</b>	3.94	100	5.87	149	3.50	89			
38	1.1/2	52x2,0	38	-2452	2.3/8	60	<b>T2730-2452</b>	3.58	91	5.63	143	3.50	89			

**NOTE:** Hose Compatibility for the T2000 series can be found on page 187.



## T2000 SERIES ONE-PIECE CRIMP COUPLINGS

### METRIC - BANJO T2470

STRAIGHT

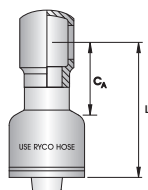

HOSE SIZE		THRD SIZE	DASH SIZE	METRIC BANJO				
DN	inch	mm		PART NO	CA		L	
					inch	mm	inch	mm
6	1/4	12	-0412	<b>T2470-0412</b>	1.14	29	2.17	55
6	1/4	14	-0414	<b>T2470-0414</b>	1.22	31	2.24	57
6	1/4	16	-0416	<b>T2470-0416</b>	1.30	33	2.32	59
8	5/16	12	-0512	<b>T2470-0512</b>	1.14	29	2.17	55
8	5/16	14	-0514	<b>T2470-0514</b>	1.22	31	2.24	57
8	5/16	16	-0516	<b>T2470-0516</b>	1.22	31	2.24	57
10	3/8	12	-0612	<b>T2470-0612</b>	1.30	33	2.28	58
10	3/8	14	-0614	<b>T2470-0614</b>	1.38	35	2.36	60
10	3/8	16	-0616	<b>T2470-0616</b>	1.38	35	2.36	60
10	3/8	18	-0618	<b>T2470-0618</b>	1.46	37	2.44	62
10	3/8	20	-0620	<b>T2470-0620</b>	1.57	40	2.56	65
10	3/8	22	-0622	<b>T2470-0622</b>	1.65	42	2.64	67
12	1/2	18	-0818	<b>T2470-0818</b>	1.50	38	2.48	63
12	1/2	22	-0822	<b>T2470-0822</b>	1.61	41	2.60	66
16	5/8	22	-1022	<b>T2470-1022</b>	2.48	63	3.70	94
16	5/8	26	-1026	<b>T2470-1026</b>	1.69	43	2.91	74
19	3/4	26	-1226	<b>T2470-1226</b>	1.85	47	3.03	77
19	3/4	30	-1230	<b>T2470-1230</b>	2.09	53	3.27	83
19	3/4	36	-1236	<b>T2470-1236</b>	2.28	58	3.46	88
25	1	30	-1630	<b>T2470-1630</b>	2.09	53	3.31	84
25	1	36	-1636	<b>T2470-1636</b>	2.28	58	3.50	89

**NOTE:** Other configurations available on request. For BBM Banjo Bolt and MBD Seal see RYCO Adaptor Catalogue

### METRIC BANJO BOLT BBM

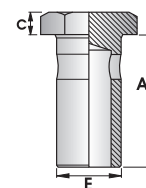

THREAD SIZE E	DIMENSIONS (MM)			METRIC BANJO BOLT
	A	C	A/F	
mm				PART NO
M10x1,0	19	6	14	<b>BBM-10</b>
M12x1,5	24	6	17	<b>BBM-12</b>
M14x1,5	26	6	19	<b>BBM-14</b>
M16x1,5	28	6	22	<b>BBM-16</b>
M18x1,5	32	6	24	<b>BBM-18</b>
M20x1,5	37	7	27	<b>BBM-20</b>
M22x1,5	39	7	27	<b>BBM-22</b>
M26x1,5	45	7	32	<b>BBM-26</b>
M30x1,5	51	7	36	<b>BBM-30</b>
M36x2,0	71	12	46	<b>BBM-36</b>

**NOTE:** MBD Seals for BBM Banjo Bolts can be found on page 432.

INTRODUCTION

HOSE

COUPLINGS

ADAPTORS

TECHNICAL

**NOTE:** Hose Compatibility for the T2000 series can be found on page 187.

# COUPLINGS

## T2000 SERIES ONE-PIECE CRIMP COUPLINGS

ORFS	T2840
------	-------

O RING  
FACE SEAL

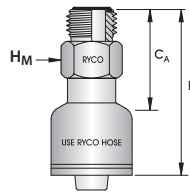

DN	HOSE SIZE		THRDS	TUBE SIZE	DASH SIZE	MALE HEX		PART NO	C <sub>A</sub>		L	
	inch	inch	inch	inch	inch	mm	inch		mm	inch	mm	
6	1/4	9/16	1/4	-0409	5/8	16	T2840-0409	1.22	31	2.24	57	
6	1/4	11/16	3/8	-0411	3/4	19	T2840-0411	1.30	33	2.28	58	
10	3/8	11/16	3/8	-0611	3/4	19	T2840-0611	1.34	34	2.32	59	
10	3/8	13/16	1/2	-0613	7/8	22	T2840-0613	1.46	37	2.44	62	
10	3/8	1	5/8	-0616	1.1/16	27	T2840-0616	1.54	39	2.52	64	
12	1/2	13/16	1/2	-0813	7/8	22	T2840-0813	1.50	38	2.48	63	
12	1/2	1	5/8	-0816	1.1/16	27	T2840-0816	1.65	42	2.64	67	
16	5/8	1	5/8	-1016	1.1/16	27	T2840-1016	1.57	40	2.76	70	
16	5/8	1.3/16	3/4	-1019	1.1/4	32	T2840-1019	1.69	43	2.91	74	
19	3/4	1.3/16	3/4	-1219	1.1/4	32	T2840-1219	1.85	47	3.03	77	
19	3/4	1.7/16	1	-1223	1.1/2	38	T2840-1223	2.05	52	3.19	81	
25	1	1.7/16	1	-1623	1.1/2	38	T2840-1623	2.01	51	3.23	82	
31	1.1/4	1.11/16	1.1/4	-2027	2	50	T2840-2027	2.28	58	4.21	107	

**NOTE:** Hose Compatibility for the T2000 series can be found on page 187.

## T2000 SERIES ONE-PIECE CRIMP COUPLINGS

<b>ORFS</b>	<b>T2800 - T2801</b>
-------------	----------------------

**O RING  
FACE SEAL**

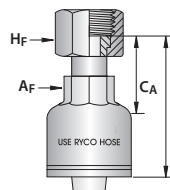

DN	HOSE SIZE		TUBE SIZE	DASH SIZE	BACK UP Af		FEMALE HEX		PART NO	ORFS FEMALE		L	
	inch	inch			inch	inch	mm	inch		mm	inch	mm	inch
6	1/4	9/16	1/4	-0409	1/2		11/16		<b>T2800-0409</b>	1.14	29	2.17	55
					12		3/4		<b>T2801-0409</b>				
6	1/4	11/16	3/8	-0411	1/2		7/8		<b>T2800-0411</b>	1.22	31	2.20	56
					12		22		<b>T2801-0411</b>				
8	5/16	11/16		-0511	14		7/8		<b>T2800-0511</b>	1.26	32	2.24	57
10	3/8	9/16	1/4	-0609	5/8		11/16		<b>T2800-0609</b>	1.22	31	2.20	56
					16		3/4		<b>T2801-0609</b>				
10	3/8	11/16	3/8	-0611	5/8		7/8		<b>T2800-0611</b>	1.26	32	2.24	57
10	3/8	13/16	1/2	-0613	5/8		15/16		<b>T2800-0613</b>	1.38	35	2.36	60
12	1/2	11/16	3/8	-0811	3/4		7/8		<b>T2800-0811</b>	1.30	33	2.28	58
12	1/2	13/16	1/2	-0813	3/4		15/16		<b>T2800-0813</b>	1.42	36	2.40	61
12	1/2	1	5/8	-0816	3/4		1.1/8		<b>T2800-0816</b>	1.50	38	2.48	63
					19		1.3/16		<b>T2801-0816</b>				
12	1/2	1.3/16	3/4	-0819	3/4		1.3/8		<b>T2800-0819</b>	1.65	42	2.60	66
					19		36		<b>T2801-0819</b>				
16	5/8	1	5/8	-1016	7/8		1.1/8		<b>T2800-1016</b>	1.38	35	2.60	66
					22		30		<b>T2801-1016</b>				
16	5/8	1.3/16	3/4	-1019	7/8		1.3/8		<b>T2800-1019</b>	1.50	38	2.72	69
					22		36		<b>T2801-1019</b>				
19	3/4	1	5/8	-1216	1.1/16		1.1/8		<b>T2800-1216</b>	1.54	39	2.68	68
					27		30		<b>T2801-1216</b>				
19	3/4	1.3/16	3/4	-1219	1.1/16		1.3/8		<b>T2800-1219</b>	1.65	42	2.83	72
					27		36		<b>T2801-1219</b>				
19	3/4	1.7/16	1	-1223	1.1/16		1.5/8		<b>T2800-1223</b>	1.65	42	2.80	71
					27		41		<b>T2801-1223</b>				
25	1	1.3/16	3/4	-1619	1.1/4		1.3/8		<b>T2800-1619</b>	1.61	41	2.83	72
					32		36		<b>T2801-1619</b>				
25	1	1.7/16	1	-1623	1.1/4		1.5/8		<b>T2800-1623</b>	1.61	41	2.83	72
31	1.1/4	1.11/16	1.1/4	-2027	1.5/8		2		<b>T2800-2027</b>	1.89	48	3.82	97
38	1.1/2	2	1.1/2	-2432	2		2.1/4		<b>T2800-2432</b>	2.32	59	4.33	110

**NOTE:** Hose Compatibility for the **T2000** series can be found on page 187.

INTRODUCTION

HOSE

COUPLINGS

ADAPTORS

TECHNICAL

# COUPLINGS

## T2000 SERIES ONE-PIECE CRIMP COUPLINGS

ORFS	T2810 - T2811	T2823 - T2824
------	---------------	---------------

O RING  
FACE SEAL

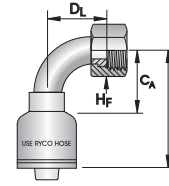
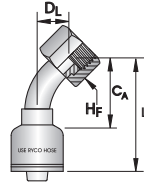

HOSE SIZE	THRD SIZE	TUBE SIZE	DASH SIZE	FEMALE HEX	ORFS FEMALE 45° TUBE BEND						ORFS FEMALE 90° SHORT BEND									
					HF-SPANNER	PART NO	CA	L	DL	PART NO	CA	L	DL							
DN	inch	inch	inch	inch	inch	mm	inch	mm	inch	mm	inch	mm	inch	mm	inch	mm	inch	mm		
6	1/4	9/16	1/4	-0409	11/16	T2810-0409	1.54	39	2.52	64	0.71	18	T2823-0409	1.06	27	2.05	52	0.83	21	
					3/4	T2811-0409							T2824-0409							
6	1/4	11/16	3/8	-0411	7/8	22	T2810-0411	1.54	39	2.52	64	0.71	18	T2823-0411	1.02	26	2.01	51	1.06	27
10	3/8	11/16	3/8	-0611	7/8	22	T2810-0611	1.77	45	2.76	70	0.79	20	T2823-0611	1.26	32	2.24	57	0.94	24
10	3/8	13/16	1/2	-0613	15/16	24	T2810-0613	1.57	40	2.56	65	0.67	17	T2823-0613	1.38	35	2.36	60	1.14	29
12	1/2	11/16	3/8	-0811	7/8	22	T2810-0811	2.13	54	3.11	79	0.87	22							
12	1/2	13/16	1/2	-0813	15/16	24	T2810-0813	1.93	49	2.87	73	0.75	19	T2823-0813	1.69	43	2.68	68	1.18	30
12	1/2	1	5/8	-0816	1.1/8	T2810-0816	1.89	48	2.87	73	0.75	19	T2823-0816	1.65	42	2.60	66	1.38	35	
					30	T2811-0816							T2824-0816							
12	1/2	1.3/16	3/4	-0819	1.3/8								T2823-0819	1.65	42	2.64	67	1.89	48	
					36					T2824-0819										
16	5/8	1	5/8	-1016	1.1/8	T2810-1016	2.32	59	3.54	90	0.79	20	T2823-1016	1.69	43	2.91	74	1.34	34	
					30	T2811-1016							T2824-1016							
16	5/8	1.3/16	3/4	-1019	1.3/8	T2810-1019	2.32	59	3.54	90	0.94	24	T2823-1019	1.77	45	2.99	76	1.89	48	
					36	T2811-1019							T2824-1019							
19	3/4	1.3/16	3/4	-1219	1.3/8	T2810-1219	3.11	79	4.25	108	1.14	29	T2823-1219	2.32	59	3.50	89	1.89	48	
					36	T2811-1219							T2824-1219							
19	3/4	1.7/16	1	-1223	1.5/8	41	T2810-1223	3.03	77	4.17	106	1.02	26	T2823-1223	2.32	59	3.50	89	2.20	56
25	1	1.7/16	1	-1623	1.5/8	41	T2810-1623	3.39	86	4.61	117	1.34	34	T2823-1623	3.19	81	4.41	112	2.20	56
31	1.1/4	1.11/16	1.1/4	-2027	2	50	T2810-2027	4.02	102	5.94	151	1.77	45	T2823-2027	3.94	100	5.87	149	2.52	64

**NOTE:** Hose Compatibility for the T2000 series can be found on page 187.

## T2000 SERIES ONE-PIECE CRIMP COUPLINGS

<b>ORFS</b>	<b>T2820 - T2821</b>	<b>T2830 - T2831</b>
-------------	----------------------	----------------------

**O RING  
FACE SEAL**

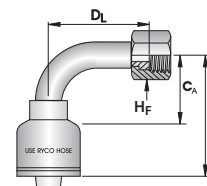
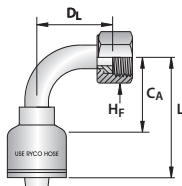

HOSE SIZE	THRD SIZE	TUBE SIZE	DASH SIZE	FEMALE HEX	ORFS FEMALE 90° MEDIUM BEND								ORFS FEMALE 90° LONG BEND							
					DN	inch	inch	inch	inch	mm	inch	mm	inch	mm	inch	mm	inch	mm	inch	mm
					HF-SPANNER	PART NO	CA	L	DL	PART NO	CA	L	DL							
					inch	mm	inch	mm	inch	mm	inch	mm	inch	mm	inch	mm	inch	mm		
6	1/4	9/16	1/4	-0409	11/16	<b>T2820-0409</b>	1.30	33	2.28	58	1.26	32	<b>T2830-0409</b>	1.30	33	2.28	58	1.85	47	
					3/4	17	<b>T2821-0409</b>						<b>T2831-0409</b>							
6	1/4	11/16	3/8	-0411	7/8	22	<b>T2820-0411</b>	1.30	33	2.28	58	1.50	38	<b>T2830-0411</b>	1.30	33	2.28	58	2.13	54
8	5/16	11/16	3/8	-0511	7/8	22	<b>T2820-0511</b>	1.38	35	2.36	60	1.50	38							
10	3/8	11/16	3/8	-0611	7/8	22	<b>T2820-0611</b>	1.38	35	2.36	60	1.50	38	<b>T2830-0611</b>	1.38	35	2.36	60	2.17	55
10	3/8	13/16	1/2	-0613	15/16	24	<b>T2820-0613</b>	1.50	38	2.48	63	1.34	34	<b>T2830-0613</b>	1.38	35	2.36	60	2.52	64
12	1/2	13/16	1/2	-0813	15/16	24	<b>T2820-0813</b>	1.61	41	2.60	66	1.61	41	<b>T2830-0813</b>	1.69	43	2.68	68	2.56	65
12	1/2	1	5/8	-0816	1.1/8		<b>T2820-0816</b>	1.61	41	2.60	66	1.85	47	<b>T2830-0816</b>	1.81	46	2.80	71	2.76	70
					30		<b>T2821-0816</b>						<b>T2831-0816</b>							
12	1/2	1.3/16	3/4	-0819	1.3/8		<b>T2820-0819</b>	1.61	41	2.60	66	2.28	58	<b>T2830-0819</b>	1.69	43	2.64	67	3.78	96
					36		<b>T2821-0819</b>						<b>T2831-0819</b>							
16	5/8	1	5/8	-1016	1.1/8		<b>T2820-1016</b>	1.77	45	2.99	76	1.85	47	<b>T2830-1016</b>	2.01	51	3.23	82	2.76	70
					30		<b>T2821-1016</b>						<b>T2831-1016</b>							
16	5/8	1.3/16	3/4	-1019	1.3/8		<b>T2820-1019</b>	1.77	45	2.99	76	2.28	58	<b>T2830-1019</b>	2.01	51	3.23	82	3.78	96
					36		<b>T2821-1019</b>						<b>T2831-1019</b>							
19	3/4	13/16	1/2	-1213	15/16	24	<b>T2820-1213</b>	2.17	55	3.35	85	1.61	41							
19	3/4	1	5/8	-1216	1.1/8		<b>T2820-1216</b>	2.17	55	3.35	85	1.85	47							
					30		<b>T2821-1216</b>													
19	3/4	1.3/16	3/4	-1219	1.3/8		<b>T2820-1219</b>	2.32	59	3.50	89	2.32	59	<b>T2830-1219</b>	2.32	59	3.50	89	3.78	96
					36		<b>T2821-1219</b>						<b>T2831-1219</b>							
19	3/4	1.7/16	1	-1223	1.5/8	41	<b>T2820-1223</b>	2.32	59	3.50	89	2.09	53	<b>T2830-1223</b>	2.32	59	3.50	89	4.49	114
25	1	1.7/16	1	-1623	1.5/8	41	<b>T2820-1623</b>	2.72	69	3.94	100	2.80	71	<b>T2830-1623</b>	2.91	74	4.13	105	4.45	113
31	1.1/4	1.11/16	1.1/4	-2027	2	50	<b>T2820-2027</b>	3.94	100	5.87	149	3.54	90	<b>T2830-2027</b>	3.94	100	5.87	149	5.08	129

<b>PW</b>	<b>T2940</b>
-----------	--------------

**PRESSURE WASHER  
SUITS KARCHER STYLE**

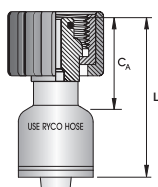

HOSE SIZE	THRD SIZE	DASH SIZE	PW FEMALE	PART NO	CA	L
DN	inch	mm	inch		inch	mm
6	1/4	22	-0422	<b>T2940-0422</b>	1.46	37
8	5/16	22	-0522	<b>T2940-0522</b>	1.46	37
10	3/8	22	-0622	<b>T2940-0622</b>	1.50	38

<b>PW</b>	<b>T2950</b>
-----------	--------------

**PRESSURE WASHER  
SUITS KARCHER STYLE**

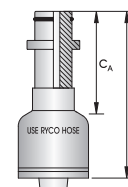

HOSE SIZE	TUBE OD	DASH SIZE	PW GUN HANDLE TUBE	PART NO	CA	L
DN	inch	mm			inch	mm
6	1/4	10	-0410	<b>T2950-0410</b>	1.81	46
8	5/16	10	-0510	<b>T2950-0510</b>	1.81	46

**NOTE:** Hose Compatibility for the **T2000** series can be found on page 187.



# COUPLINGS

## T2000 SERIES ONE-PIECE CRIMP COUPLINGS

<b>RYCOLOK</b>	<b>T2870</b>	<b>T2871</b>
----------------	--------------	--------------

STAPLE  
O RING & BACK UP  
RING SUPPLIED

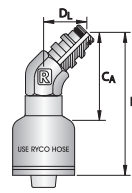
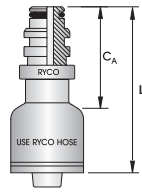

HOSE SIZE				STAPLE SIZE	DASH SIZE	RYCOLOK MALE				RYCOLOK MALE 45° ELBOW					
DN	inch	mm		PART NO	CA		L		PART NO	CA		L		DL	
					inch	mm	inch	mm		inch	mm	inch	mm	inch	mm
6	1/4	6	-0406	<b>T2870-0406</b>	1.81	46	2.80	71	<b>T2871-0406</b>	2.01	51	2.99	76	1.10	28
6	1/4	10	-0410	<b>T2870-0410</b>	1.85	47	2.83	72	<b>T2871-0410</b>	2.05	52	3.03	77	1.10	28
10	3/8	10	-0610	<b>T2870-0610</b>	1.81	46	2.80	71	<b>T2871-0610</b>	2.09	51	2.99	76	1.10	28
12	1/2	12	-0812	<b>T2870-0812</b>	1.93	49	2.91	74	<b>T2871-0812</b>		55	3.15	80	1.10	28
12	1/2	16	-0816	<b>T2870-0816</b>	1.93	49	2.91	74		53					
16	5/8	12	-1012	<b>T2870-1012</b>	1.81	46	3.03	77							
16	5/8	16	-1016	<b>T2870-1016</b>	1.73	44	2.95	75	<b>T2871-1016</b>	3.07					
19	3/4	20	-1220	<b>T2870-1220</b>	1.89	48	3.07	78	<b>T2871-1220</b>		66	3.74	95	1.30	33
25	1	25	-1625	<b>T2870-1625</b>	2.28	58	3.46	88	<b>T2871-1625</b>	78	70	3.98	101	1.46	37
31	1.1/4	32	-2032	<b>T2870-2032</b>	2.32	59	4.25	108	<b>T2871-2032</b>		75	4.88	124	1.46	37
38	1.1/2	40	-2440	<b>T2870-2440</b>	2.36	60	4.37	111	<b>T2871-2440</b>	1.06	82	5.28	134	1.73	44
51	2	50	-3250	<b>T2870-3250</b>	2.28	58	4.49	114	<b>T2871-3250</b>		87	5.63	143	1.81	46
63	2.1/2	63	-4063	<b>T2870-4063</b>	3.54	90	6.57	167	<b>T2871-4063</b>	27	114	7.52	191	2.87	73
76	3	75	-4875	<b>T2870-4875</b>	5.00	127	7.99	203							

<b>RYCOLOK</b>	<b>T2872</b>
----------------	--------------

STAPLE  
O RING & BACK UP  
RING SUPPLIED

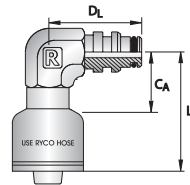

HOSE SIZE				STAPLE SIZE	DASH SIZE	RYCOLOK MALE 90° ELBOW					
DN	inch	mm		PART NO	CA		L		DL		
					inch	mm	inch	mm	inch	mm	
6	1/4	6	-0406	<b>T2872-0406</b>	1.10	28	2.13	54	1.81	46	
6	1/4	10	-0410	<b>T2872-0410</b>	1.14	29	2.13	54	1.81	46	
10	3/8	10	-0610	<b>T2872-0610</b>	1.22	31	2.20	56	1.81	46	
12	1/2	12	-0812	<b>T2872-0812</b>	1.54	39	2.52	64	1.97	50	
16	5/8	16	-1016	<b>T2872-1016</b>	2.76	70	3.98	101	2.05	52	
19	3/4	20	-1220	<b>T2872-1220</b>	1.73	44	2.87	73	2.20	56	
25	1	25	-1625	<b>T2872-1625</b>	2.05	52	3.27	83	2.68	68	
31	1.1/4	32	-2032	<b>T2872-2032</b>	2.36	60	4.29	109	2.68	68	
38	1.1/2	40	-2440	<b>T2872-2440</b>	2.40	61	4.45	113	3.35	85	
51	2	50	-3250	<b>T2872-3250</b>	2.60	66	4.80	122	3.94	100	
63	2.1/2	63	-4063	<b>T2872-4063</b>	3.15	80	6.18	157	5.51	140	

**NOTE:** Hose Compatibility for the **T2000** series can be found on page 187.

## T2000 SERIES ONE-PIECE CRIMP COUPLINGS

<b>RYCO WEO</b>	<b>T2480</b>	<b>T2482</b>
-----------------	--------------	--------------

RYCO WEO

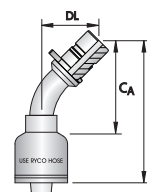
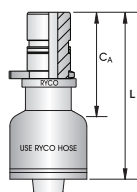

HOSE SIZE		PLUG-IN SIZE		MAX WORKING PRESSURE		RYCO WEO MALE				RYCO WEO MALE 45° TUBE BEND									
DN	Dash	inch	DN	inch	bar	psi	PART NO	CA		L		PART NO	CA		L		DL		
								inch	mm	inch	mm		inch	mm	inch	mm	inch	mm	
5	-0304	3/16	6	1/4	350	5100	<b>T2480-0304</b>	1.22	31	1.97	50								
6	-0404	1/4	6	1/4	350	5100	<b>T2480-0404</b>	1.46	37	2.48	63	<b>T2482-0404</b>	1.73	44	2.72	69	0.98	25	
6	-0406	1/4	10	3/8	350	5100	<b>T2480-0406</b>	1.61	41	2.64	67								
8	-0506	5/16	10	3/8	350	5100	<b>T2480-0506</b>	1.61	41	2.64	67	<b>T2482-0506</b>	2.13	54	3.11	79	1.06	27	
10	-0606	3/8	10	3/8	350	5100	<b>T2480-0606</b>	1.69	43	2.68	68	<b>T2482-0606</b>	2.17	55	3.15	80	1.06	27	
10	-0608	3/8	12	1/2	350	5100	<b>T2480-0608</b>	1.69	43	2.68	68								
12	-0808	1/2	12	1/2	350	5100	<b>T2480-0808</b>	1.73	44	2.72	69	<b>T2482-0808</b>	2.32	59	3.31	84	1.22	31	
12	-0812	1/2	19	3/4	350	5100	<b>T2480-0812</b>	2.17	55	3.15	80								
16	-1012	5/8	19	3/4	350	5100	<b>T2480-1012</b>	1.97	50	3.19	81	<b>T2482-1012</b>	2.83	72	4.06	103	1.57	40	
19	-1212	3/4	19	3/4	350	5100	<b>T2480-1212</b>	2.13	54	3.31	84	<b>T2482-1212</b>	3.23	82	4.41	112	1.69	43	
25	-1616	1	25	1	250	3600	<b>T2480-1616</b>	2.52	64	3.70	94	<b>T2482-1616</b>	4.13	105	5.35	136	2.09	53	

**NOTE:** RYCO WEO male and female couplings and adaptors do not contain a shut-off valve. When not in use, cap the RYCO WEO male using the appropriate size RW811 series stop cap and plug the RYCO WEO female/cartridge using the appropriate size RW723 series stop plug.

<b>RYCO WEO</b>	<b>T2483</b>
-----------------	--------------

RYCO WEO

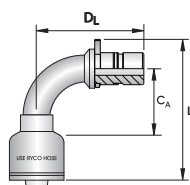

HOSE SIZE		PLUG-IN SIZE		MAX WORKING PRESSURE		RYCO WEO MALE 90° TUBE BEND						
DN	inch	DN	inch	bar	psi	PART NO	CA		L		DL	
							inch	mm	inch	mm	inch	mm
6	1/4	6	1/4	350	5100	<b>T2483-0404</b>	1.14	29	2.13	54	1.57	40
8	5/16	10	3/8	350	5100	<b>T2483-0506</b>	1.38	35	2.36	60	1.06	27
10	3/8	10	3/8	350	5100	<b>T2483-0606</b>	1.38	35	2.36	60	2.05	52
10	3/8	12	1/2	350	5100	<b>T2483-0608</b>	1.42	36	2.40	61	1.85	47
12	1/2	12	1/2	350	5100	<b>T2483-0808</b>	1.50	38	2.48	63	2.28	58
16	5/8	19	3/4	350	5100	<b>T2483-1012</b>	1.89	48	3.11	79	2.80	71
19	3/4	19	3/4	350	5100	<b>T2483-1212</b>	2.32	59	3.50	89	3.23	82
25	1	25	1	250	3600	<b>T2483-1616</b>	2.83	72	4.06	103	3.94	100

**NOTE:** RYCO WEO male and female couplings and adaptors do not contain a shut-off valve. When not in use, cap the RYCO WEO male using the appropriate size RW811 series stop cap and plug the RYCO WEO female/cartridge using the appropriate size RW723 series stop plug.

**NOTE:** Hose Compatibility for the T2000 series can be found on page 187.

INTRODUCTION

HOSE

COUPLINGS

ADAPTORS

TECHNICAL

# COUPLINGS

## T2000 SERIES ONE-PIECE CRIMP COUPLINGS

SAE	T2530
-----	-------

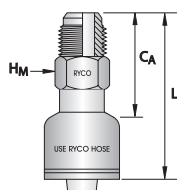

45° FLARE

HOSE SIZE	THRD SIZE	TUBE SIZE	DASH SIZE	MALE HEX	SAE MALE						
DN	inch	inch	inch	DASH	HM-SPANNER		PART NO	CA		L	
					inch	mm		inch	mm	inch	mm
6	1/4	5/8	3/8	-0410	5/8	16	T2530-0410	1.34	34	2.32	59
10	3/8	1/2	5/16	-0608	1/2		T2530-0608	1.34	34	2.32	59
10	3/8	5/8	3/8	-0610	5/8	16	T2530-0610	1.46	37	2.44	62

**NOTE:** Hose Compatibility for the **T2000** series can be found on page 187.

## T2000 SERIES ONE-PIECE CRIMP COUPLINGS

INTRODUCTION

HOSE

COUPLINGS

ADAPTORS

TECHNICAL

### SAE T2540

45° FLARE

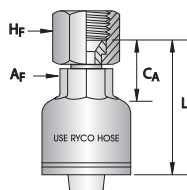

HOSE SIZE	THRD SIZE	TUBE SIZE	DASH SIZE	BACK UP AF	FEMALE HEX		SAE FEMALE						
DN	inch	inch	inch		AF-SPANNER		HF-SPANNER		PART NO	CA		L	
	inch	inch	inch		inch	mm	inch	mm		inch	mm	inch	mm
6	1/4	7/16	1/4	-0407	1/2		9/16		<b>T2540-0407</b>	1.02	26	2.05	52
6	1/4	5/8	3/8	-0410	1/2		3/4	19	<b>T2540-0410</b>	1.14	29	2.17	55
10	3/8	1/2	5/16	-0608	5/8	16	5/8	16	<b>T2540-0608</b>	1.10	28	2.09	53
10	3/8	5/8	3/8	-0610	5/8	16	3/4	19	<b>T2540-0610</b>	1.22	31	2.20	56
19	3/4	1.1/16	3/4	-1217	1.1/16	27	1.1/4	32	<b>T2540-1217</b>	1.22	31	2.40	61

### SAE T2580 T2570

45° FLARE

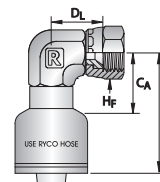
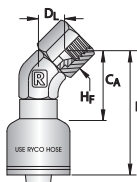

HOSE SIZE	THRD SIZE	TUBE SIZE	DASH SIZE	FEMALE HEX	SAE FEMALE 45° ELBOW						SAE FEMALE 90° ELBOW									
DN	inch	inch	inch		HF-SPANNER		PART NO	CA		L		DL		PART NO	CA		L		DL	
	inch	inch	inch		inch	mm		inch	mm	inch	mm	inch	mm		inch	mm	inch	mm	inch	mm
10	3/8	1/2	5/16	-0608	5/8	16	<b>T2580-0608</b>	1.57	40	2.56	65	0.59	15	<b>T2570-0608</b>	1.22	31	2.20	56	0.87	22
10	3/8	5/8	3/8	-0610	3/4	19	<b>T2580-0610</b>	1.57	40	2.56	65	0.59	15	<b>T2570-0610</b>	1.22	31	2.20	56	0.91	23

### SAE T2740

INVERTED MALE FLARE

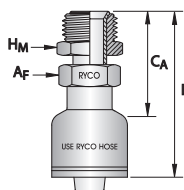

HOSE SIZE	THRD SIZE	TUBE SIZE	DASH SIZE	BACK UP AF	MALE HEX		SAE INVERTED MALE FLARE						
DN	inch	inch	inch		AF-SPANNER		HM-SPANNER		PART NO	CA		L	
	inch	inch	inch		inch	mm	inch	mm		inch	mm	inch	mm
6	1/4	7/16	1/4	-0407	1/2		1/2		<b>T2740-0407</b>	1.85	47	2.83	72
10	3/8	5/8	3/8	-0610	5/8	16	5/8	16	<b>T2740-0610</b>	1.61	41	2.60	66
10	3/8	11/16	7/16	-0611	5/8	16	5/8	16	<b>T2740-0611</b>	2.05	52	3.07	78

**NOTE:** Hose Compatibility for the T2000 series can be found on page 187.

# COUPLINGS

## T2000 SERIES ONE-PIECE CRIMP COUPLINGS

SAE	T2780
-----	-------

INVERTED  
MALE FLARE

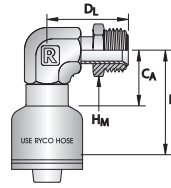

HOSE SIZE	THRD SIZE	TUBE SIZE	DASH SIZE	BACK UP AF	MALE HEX	SAE INVERTED MALE FLARE 90° ELBOW										
DN	inch	inch	inch		AF-SPANNER		HM-SPANNER		PART NO		CA		L		DL	
					inch	mm	inch	mm	inch	mm	inch	mm	inch	mm	inch	mm
10	3/8	5/8	3/8	-0610	3/4	19	3/4	19	T2780-0610		1.22	31	2.20	56	1.26	32
10	3/8	11/16	7/16	-0611	3/4	19	3/4	19	T2780-0611		1.02	26	2.01	51	1.42	36

SAE	T2790	T2750
-----	-------	-------

INVERTED  
MALE FLARE

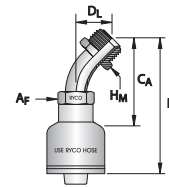
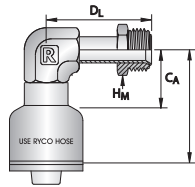

HOSE SIZE	THRD SIZE	TUBE SIZE	DASH SIZE	BACK UP AF	MALE HEX	SAE INVERTED MALE FLARE 90° EXTENDED ELBOW										SAE INVERTED MALE FLARE 45° TUBE BEND								
DN	inch	inch	inch		AF-SPANNER		HM-SPANNER		PART NO		CA		L		DL		PART NO		CA		L		DL	
					inch	mm	inch	mm	inch	mm	inch	mm	inch	mm	inch	mm	inch	mm	inch	mm	inch	mm	inch	mm
10	3/8	5/8	3/8	-0610	3/4	19	3/4	19	T2790-0610		1.02	26	2.01	51	2.36	60	T2750-0610		2.87	73	3.86	98	0.91	23

SAE	T2760	T2770
-----	-------	-------

INVERTED  
MALE FLARE

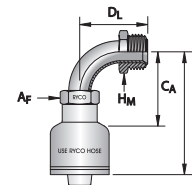
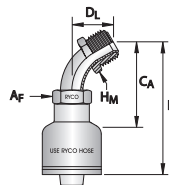

HOSE SIZE	THRD SIZE	TUBE SIZE	DASH SIZE	BACK UP AF	MALE HEX	SAE INVERTED MALE FLARE 60° TUBE BEND										SAE INVERTED MALE FLARE 90° TUBE BEND								
DN	inch	inch	inch		AF-SPANNER		HM-SPANNER		PART NO		CA		L		DL		PART NO		CA		L		DL	
					inch	mm	inch	mm	inch	mm	inch	mm	inch	mm	inch	mm	inch	mm	inch	mm	inch	mm	inch	mm
6	1/4	7/16	1/4	-0407	1/2		7/16		T2760-0407		2.72	69	3.74	95	1.14	29	T2770-0407		1.97	50	2.99	76	1.50	38
10	3/8	5/8	3/8	-0610	5/8	16	5/8	16	T2770-0610		2.48	63	3.50	89	1.97	50								

**NOTE:** Hose Compatibility for the T2000 series can be found on page 187.



## T2000 SERIES ONE-PIECE CRIMP COUPLINGS

### DIMENSIONS FOR SAE CODE 61 AND CODE 62 FLANGES, AND RYCO CODE 62C FLANGES

NOMINAL FLANGE	CODE 61				CODE 62				CODE 62C			
	B		T		B		T		B		T	
inch	mm	inch	mm	inch	mm	inch	mm	inch	mm	inch	mm	inch
1/2	30,2	1.19	6,73	0.265	31,8	1.25	7,75	0.305				
5/8	34,0	1.34	6,73	0.265								
3/4	38,1	1.50	6,73	0.265	41,3	1.63	8,76	0.345	41,3	1.63	14,20	0.559
1	44,5	1.75	8,00	0.315	47,6	1.88	9,53	0.375	47,6	1.88	14,20	0.559
1.1/4	50,8	2.00	8,00	0.315	54,0	2.12	10,29	0.405	54,0	2.12	14,20	0.559
1.1/2	60,3	2.38	8,00	0.315	63,5	2.50	12,57	0.495	63,5	2.50	14,20	0.559
2	71,4	2.81	9,53	0.375	79,4	3.13	12,57	0.495	79,4	3.13	14,20	0.559
2.1/2	84,1	3.31	9,53	0.375								
3	101,6	4.00	9,53	0.375								

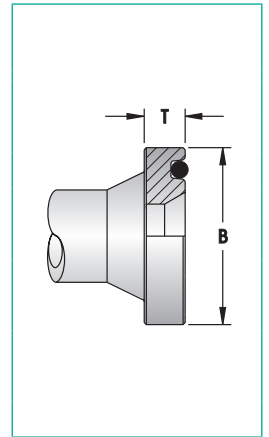

INTRODUCTION

HOSE

COUPLINGS

ADAPTORS

TECHNICAL

**NOTE:** RYCO Code 62C fittings conform to the flange OD and bolt hole patterns of SAE Code 62 but require special flange clamps. RYCO Code 62C flange heads are thicker than SAE Code 62 and measure T = 14,2 mm (0.559 inch) in all sizes.

SAE FLANGE	T2130	T2150
------------	-------	-------

RYCO  
CODE 61  
CLAMPS - SEE PAGES  
440 & 441  
O RING NOT SUPPLIED

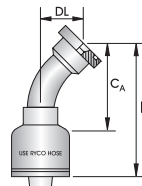
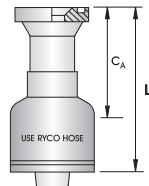

HOSE SIZE	NOM. FLANGE SIZE	DASH SIZE	CODE 61 FLANGE				CODE 61 FLANGE 45° TUBE BEND								
			PART NO	CA	L		PART NO	CA	L		DL				
DN	inch	inch	inch	inch	mm	inch	mm	inch	mm	inch	mm	inch	mm		
12	1/2	1/2	-0808	T2130-0808	1.77	45	2.76	70	T2150-0808	1.93	49	2.91	74	0.79	20
12	1/2	3/4	-0812	T2130-0812	1.89	48	2.83	72	T2150-0812	2.01	51	2.99	76	0.94	24
16	5/8	5/8	-1010	T2130-1010	1.73	44	2.95	75	T2150-1010	2.20	56	3.43	87	0.94	24
19	3/4	5/8	-1210	T2130-1210	1.77	45	2.95	75	T2150-1210	2.32	59	3.50	89	1.02	26
19	3/4	3/4	-1212	T2130-1212	1.81	46	2.99	76	T2150-1212	2.56	65	3.74	95	1.02	26
19	3/4	1	-1216	T2130-1216	1.97	50	3.15	80	T2150-1216	2.68	68	3.86	98	1.18	30
25	1	3/4	-1612	T2130-1612	1.89	48	3.11	79	T2150-1612	2.95	75	4.17	106	1.10	28
25	1	1	-1616	T2130-1616	2.05	52	3.23	82	T2150-1616	3.19	81	4.41	112	1.18	30
25	1	1.1/4	-1620	T2130-1620	2.24	57	3.46	88	T2150-1620	3.27	83	4.49	114	1.26	32
25	1	1.1/2	-1624	T2130-1624	3.31	84	4.53	115	T2150-1624	3.35	85	4.57	116	1.57	40
31	1.1/4	1	-2016	T2130-2016	2.13	54	4.06	103	T2150-2016	3.46	88	5.39	137	1.18	30
31	1.1/4	1.1/4	-2020	T2130-2020	2.32	59	4.25	108	T2150-2020	3.94	100	5.87	149	1.42	36
31	1.1/4	1.1/2	-2024	T2130-2024	3.35	85	5.28	134	T2150-2024	4.06	103	5.98	152	1.57	40
38	1.1/2	1.1/2	-2424	T2130-2424	3.35	85	5.39	137	T2150-2424	4.33	110	6.38	162	1.65	42
38	1.1/2	2	-2432	T2130-2432	3.74	95	5.79	147							
51	2	2	-3232	T2130-3232	3.78	96	5.98	152	T2150-3232	5.91	150	8.11	206	2.28	58
51	2	2.1/2	-3240	T2130-3240	3.98	101	6.18	157							
63	2.1/2	2.1/2	-4040	T2130-4040	3.11	79	6.14	156							
76	3	3	-4848	T2130-4848	3.15	80	6.14	156							

**NOTE:** Hose Compatibility for the T2000 series can be found on page 187.

# COUPLINGS

## T2000 SERIES ONE-PIECE CRIMP COUPLINGS

<b>SAE FLANGE</b>	<b>T2170</b>
-------------------	--------------

**RYCO  
CODE 61  
CLAMPS - SEE PAGES  
440 & 441  
O RING NOT SUPPLIED**

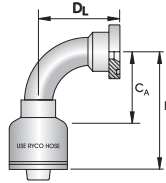

HOSE SIZE		NOM. FLANGE SIZE	DASH SIZE	CODE 61 FLANGE 90° TUBE BEND						
DN	inch	inch		PART NO	CA		L		DL	
					inch	mm	inch	mm	inch	mm
12	1/2	1/2	-0808	<b>T2170-0808</b>	1.57	40	2.56	65	1.61	41
12	1/2	3/4	-0812	<b>T2170-0812</b>	1.57	40	2.56	65	1.81	46
16	5/8	5/8	-1010	<b>T2170-1010</b>	1.89	48	3.07	78	1.89	48
19	3/4	3/4	-1212	<b>T2170-1212</b>	2.17	55	3.35	85	2.13	54
19	3/4	1	-1216	<b>T2170-1216</b>	2.17	55	3.35	85	2.36	60
25	1	3/4	-1612	<b>T2170-1612</b>	2.36	60	3.58	91	2.13	54
25	1	1	-1616	<b>T2170-1616</b>	2.83	72	4.06	103	2.68	68
25	1	1.1/4	-1620	<b>T2170-1620</b>	2.83	72	4.06	103	2.72	69
31	1.1/4	1	-2016	<b>T2170-2016</b>	3.15	80	5.08	129	2.68	68
31	1.1/4	1.1/4	-2020	<b>T2170-2020</b>	3.94	100	5.87	149	3.07	78
31	1.1/4	1.1/2	-2024	<b>T2170-2024</b>	3.94	100	5.87	149	3.19	81
38	1.1/2	1.1/2	-2424	<b>T2170-2424</b>	4.09	104	6.14	156	3.66	93
51	2	2	-3232	<b>T2170-3232</b>	5.39	137	7.60	193	5.12	130
51	2	2.1/2	-3240	<b>T2170-3240</b>	5.55	141	7.76	197	5.28	134

<b>SALVAGE</b>	<b>T2230</b>
----------------	--------------

**TUBE WELD**

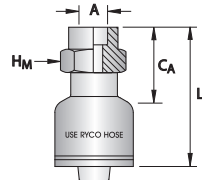

HOSE SIZE		A	DASH SIZE	MALE HEX		SALVAGE (LIFESAVER)				
DN	inch	inch		HM-SPANNER		PART NO	CA		L	
				inch	mm		inch	mm	inch	mm
6	1/4	1/4	-0404	1/2		<b>T2230-0404</b>	0.98	25	1.97	50
6	1/4	5/16	-0405	1/2		<b>T2230-0405</b>	0.98	25	1.97	50
6	1/4	3/8	-0406	5/8	16	<b>T2230-0406</b>	0.98	25	1.97	50
8	5/16	5/16	-0505	1/2		<b>T2230-0505</b>	0.98	25	1.97	50
10	3/8	3/8	-0606	5/8	16	<b>T2230-0606</b>	1.02	26	2.05	52
10	3/8	1/2	-0608	3/4	19	<b>T2230-0608</b>	1.02	26	2.05	52
12	1/2	1/2	-0808	3/4	19	<b>T2230-0808</b>	1.06	27	2.05	52
12	1/2	5/8	-0810	15/16	24	<b>T2230-0810</b>	1.14	29	2.13	54
16	5/8	5/8	-1010	15/16	24	<b>T2230-1010</b>	1.02	26	2.24	57
16	5/8	3/4	-1012	1.1/16	27	<b>T2230-1012</b>	1.02	26	2.24	57
19	3/4	3/4	-1212	1.1/16	27	<b>T2230-1212</b>	1.18	30	2.36	60
25	1	1	-1616	1.3/8		<b>T2230-1616</b>	1.38	35	2.56	65
31	1.1/4	1.1/4	-2020	1.5/8	41	<b>T2230-2020</b>	1.57	40	3.54	90
38	1.1/2	1.1/2	-2424	2	50	<b>T2230-2424</b>	1.34	34	3.39	86
51	2	2	-3232	2.1/2		<b>T2230-3232</b>	1.61	41	3.86	98

## T2000 SERIES ONE-PIECE CRIMP COUPLINGS

### STANDPIPE T2180

IMPERIAL

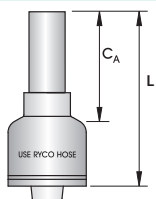

HOSE SIZE	TUBE SIZE	DASH SIZE	IMPERIAL STANDPIPE					
-----------	-----------	-----------	--------------------	--	--	--	--	--

DN	inch		PART NO	CA		L		
	inch	inch		inch	mm	inch	mm	
6	1/4	3/8	-0406	<b>T2180-0406</b>	1.42	36	2.44	62
10	3/8	3/8	-0606	<b>T2180-0606</b>	1.46	37	2.44	62
12	1/2	1/2	-0808	<b>T2180-0808</b>	1.50	38	2.48	63
12	1/2	5/8	-0810	<b>T2180-0810</b>	1.73	44	2.72	69
19	3/4	3/4	-1212	<b>T2180-1212</b>	2.09	53	3.27	83
25	1	1	-1616	<b>T2180-1616</b>	2.17	55	3.39	86

### STANDPIPE T2640 T2643

METRIC

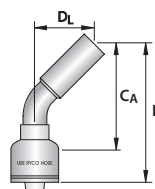
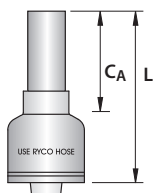

HOSE SIZE	TUBE SIZE	DASH SIZE	METRIC STANDPIPE						METRIC STANDPIPE 45° TUBE BEND							
			PART NO		CA		L		PART NO		CA		L		DL	
DN	inch	mm	inch	mm	inch	mm	inch	mm	inch	mm	inch	mm	inch	mm	inch	mm

5	3/16	6	-0306	<b>T2640-0306</b>	1.22	31	1.97	50								
6	1/4	6	-0406	<b>T2640-0406</b>	1.46	37	2.48	63	<b>T2643-0406</b>							
6	1/4	8	-0408	<b>T2640-0408</b>	1.34	34	2.36	60	<b>T2643-0408</b>							
6	1/4	10	-0410	<b>T2640-0410</b>	1.42	36	2.44	62	<b>T2643-0410</b>							
6	1/4	12	-0412	<b>T2640-0412</b>	1.42	36	2.44	62								
8	5/16	10	-0510	<b>T2640-0510</b>	1.42	36	2.44	62								
8	5/16	12	-0512	<b>T2640-0512</b>	1.42	36	2.44	62								
10	3/8	10	-0610	<b>T2640-0610</b>	1.46	37	2.44	62	<b>T2643-0610</b>							
10	3/8	12	-0612	<b>T2640-0612</b>	1.50	38	2.48	63	<b>T2643-0612</b>							
10	3/8	14	-0614	<b>T2640-0614</b>	1.77	45	2.76	70	<b>T2643-0614</b>							
12	1/2		-0812	<b>T2640-0812</b>	1.54	39	2.52	64								
12	1/2		-0814	<b>T2640-0814</b>	1.77	45	2.76	70								
12	1/2	15	-0815	<b>T2640-0815</b>	1.61	41	2.60	66	<b>T2643-0815</b>							
12	1/2	16	-0816	<b>T2640-0816</b>	1.81	46	2.80	71	<b>T2643-0816</b>							
16	5/8	16	-1016	<b>T2640-1016</b>	1.61	41	2.83	72								
16	5/8	18	-1018	<b>T2640-1018</b>	1.50	38	2.72	69	<b>T2643-1018</b>							
16	5/8	20	-1020	<b>T2640-1020</b>	1.97	50	3.19	81	<b>T2643-1020</b>							
16	5/8	22	-1022	<b>T2640-1022</b>	1.65	42	2.87	73								
19	3/4	15	-1215	<b>T2640-1215</b>	1.69	43	2.87	73								
19	3/4	20	-1220	<b>T2640-1220</b>	2.09	53	3.27	83	<b>T2643-1220</b>							
19	3/4	22	-1222	<b>T2640-1222</b>	1.73	44	2.91	74	<b>T2643-1222</b>							
19	3/4	25	-1225	<b>T2640-1225</b>	2.09	53	3.27	83	<b>T2643-1225</b>							
25	1	25	25	<b>T2640-1625</b>	2.17	55	3.39	86								
25	1	28	-1628	<b>T2640-1628</b>	2.05	52	3.27	83	<b>T2643-1628</b>							
25	1	30	-1630	<b>T2640-1630</b>	2.48	63	3.70	94	<b>T2643-1630</b>							

NOTE: See 432 for DKL and DKS Metric Nuts and olives for use with Metric Standpipe Fittings.

INTRODUCTION

HOSE

COUPLINGS

ADAPTORS

TECHNICAL

# COUPLINGS

## T2000 SERIES ONE-PIECE CRIMP COUPLINGS

STANDPIPE

T2646

METRIC

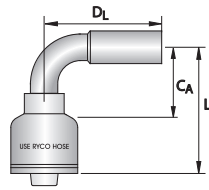

HOSE SIZE		TUBE SIZE	DASH SIZE	METRIC STANDPIPE 90° TUBE BEND						
DN	inch	mm		PART NO	CA		L		DL	
					inch	mm	inch	mm	inch	mm
6	1/4	6	-0406	<b>T2646-0406</b>						
6	1/4	8	-0408	<b>T2646-0408</b>						
6	1/4	10	-0410	<b>T2646-0410</b>						
6	1/4	12	-0412	<b>T2646-0412</b>						
10	13/32		-0610	<b>T2646-0610</b>						
10	3/8	12	-0612	<b>T2646-0612</b>						
10	3/8	14	-0614	<b>T2646-0614</b>						
12	1/2		-0812	<b>T2646-0812</b>						
12	1/2		-0814	<b>T2646-0814</b>						
				<b>T2646-0815</b>						
12	1/2	16	-0816	<b>T2646-0816</b>						
				<b>T2646-0818</b>						
16	5/8	18	-1018	<b>T2646-1018</b>						
16	5/8	22	-1022	<b>T2646-1022</b>						
19	3/4	20	-1220	<b>T2646-1220</b>						
19	3/4	22	-1222	<b>T2646-1222</b>						
19	3/4	25	-1225	<b>T2646-1225</b>						
25	1	25	-1625	<b>T2646-1625</b>						
				<b>T2646-1628</b>						
25	1	30	-1630	<b>T2646-1630</b>						
				<b>T2646-2035</b>						

**NOTE:** See page 432 for DKL and DKS Metric Nuts and olives for use with Metric Standpipe Fittings.

**NOTE:** Hose Compatibility for the **T2000** series can be found on page 187.

## T2000 SERIES ONE-PIECE CRIMP COUPLINGS

### TUBE BITE

T2850

COMPLETE WITH NUT AND FLARELESS OLIVE

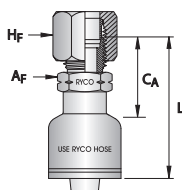

HOSE SIZE	TUBE SIZE	DASH SIZE	BACK UP AF	FEMALE HEX	TUBE BITE						
DN	inch	inch	inch	mm	AF-SPANNER	HF-SPANNER	PART NO	CA	L		
					inch	mm		inch	mm	inch	mm
6	1/4	7/16	-0404	1/2		9/16	<b>T2850-0404</b>	1.14	29	2.17	55
6	1/4	1/2	-0405	9/16		5/8	<b>T2850-0405</b>	1.18	30	2.20	56
8	5/16	1/2	-0505	9/16		5/8	<b>T2850-0505</b>	1.22	31	2.20	56
10	3/8	1/2	-0605	9/16		5/8	<b>T2850-0605</b>	1.26	32	2.24	57
10	3/8	9/16	-0606	5/8	16	11/16	<b>T2850-0606</b>	1.30	33	2.28	58
10	3/8	3/4	-0608	13/16		7/8	<b>T2850-0608</b>	1.42	36	2.40	61
12	1/2	3/4	-0808	13/16		7/8	<b>T2850-0808</b>	1.46	37	2.44	62
12	1/2	7/8	-0810	15/16	24	1	<b>T2850-0810</b>	1.54	39	2.52	64
19	3/4	1.1/16	-1212	1.1/8		1.1/4	<b>T2850-1212</b>	1.73	44	2.87	73
25	1	1.5/16	-1616	1.3/8		1.1/2	<b>T2850-1616</b>	1.81	46	3.03	77

### UNO (O RING BOSS)

T2200

T2380

O RING SUPPLIED

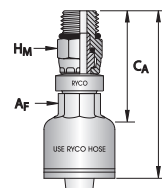
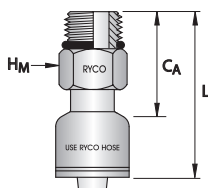

HOSE SIZE	THRD SIZE	TUBE SIZE	DASH SIZE	BACK UP AF	MALE HEX	UN O RING MALE				UN O RING MALE SWIVEL							
DN	inch	inch	inch	inch	mm	AF-SPANNER	HM-SPANNER	PART NO	CA	L		PART NO	CA	L			
						inch	mm		inch	mm	inch	mm	inch	mm	inch	mm	
6	1/4	7/16	1/4	-0407	9/16		9/16	<b>T2200-0407</b>	1.06	27	2.05	52					
6	1/4	1/2	5/16	-0408	5/8	16	5/8	<b>T2200-0408</b>	1.06	27	2.05	52					
6	1/4	9/16	3/8	-0409	11/16		11/16	<b>T2200-0409</b>	1.14	29	2.13	54					
10	3/8	9/16	3/8	-0609	11/16		11/16	<b>T2200-0609</b>	1.18	30	2.20	56	<b>T2380-0609</b>	1.61	41	2.60	66
10	3/8	3/4	1/2	-0612	7/8	22	7/8	<b>T2200-0612</b>	1.34	34	2.32	59	<b>T2380-0612</b>	1.73	44	2.72	69
10	3/8	7/8	5/8	-0614	1.1/16	27	1.1/16	<b>T2200-0614</b>	1.42	36	2.40	61					
12	1/2	3/4	1/2	-0812	7/8	22	7/8	<b>T2200-0812</b>	1.34	34	2.32	59	<b>T2380-0812</b>	1.77	45	2.76	70
12	1/2	7/8	5/8	-0814	1.1/16	27	1.1/16	<b>T2200-0814</b>	1.46	37	2.44	62	<b>T2380-0814</b>	1.81	46	2.80	71
12	1/2	1.1/16	3/4	-0817	1.1/4	32	1.1/4	<b>T2200-0817</b>	1.61	41	2.60	66	<b>T2380-0817</b>	1.93	49	2.91	74
16	5/8	7/8	5/8	-1014	1.1/16	27	1.1/16	<b>T2200-1014</b>	1.34	34	2.56	65	<b>T2380-1014</b>	1.69	43	2.91	74
16	5/8	1.1/16	3/4	-1017	1.1/4	32	1.1/4	<b>T2200-1017</b>	1.57	40	2.80	71					
19	3/4	1.1/16	3/4	-1217	1.1/4	32	1.1/4	<b>T2200-1217</b>	1.73	44	2.87	73	<b>T2380-1217</b>	2.01	51	3.15	80
19	3/4	1.5/16	1	-1221	1.1/2	38	1.1/2	<b>T2200-1221</b>	1.73	44	2.91	74					
25	1	1.5/16	1	-1621	1.1/2	38	1.1/2	<b>T2200-1621</b>	1.73	44	2.95	75					
31	1.1/4	1.5/8	1.1/4	-2026	2	50	2	<b>T2200-2026</b>	2.01	51	3.94	100					

**NOTE:** The "Live Swivel" T2380 Series Insert is for Maximum Working Pressure: 350 bar (5100 psi): -09 & -12 Thread Size, 280 bar (4100 psi): -14 & -17 Thread Size. Their swivel capability is to allow easy installation and orientation and avoid twisting of hose. They are not designed for continuous rotation or continuous movement.

**NOTE:** Hose Compatibility for the T2000 series can be found on page 187.

INTRODUCTION

HOSE

COUPLINGS

ADAPTORS

TECHNICAL



# COUPLINGS

## T2000 SERIES ONE-PIECE CRIMP COUPLINGS

UNO (O RING BOSS)

T2390

O RING SUPPLIED

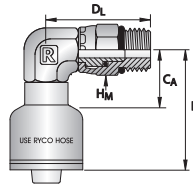

HOSE SIZE					MALE HEX		UN O RING MALE SWIVEL 90° ELBOW						
DN	inch	inch	inch	DASH SIZE	inch	mm	PART NO	CA		L		DL	
								inch	mm	inch	mm	inch	mm
10	3/8	9/16	3/8	-0609	3/4	19	<b>T2390-0609</b>	1.77	45	2.76	70	0.91	23
10	3/8	3/4	1/2	-0612	3/4	19	<b>T2390-0612</b>	1.97	50	2.95	75	0.91	23
10	3/8	7/8	5/8	-0614	3/4	19	<b>T2390-0614</b>	2.01	51	2.99	76	0.91	23
12	1/2	3/4	1/2	-0812	7/8	22	<b>T2390-0812</b>	2.05	52	3.03	77	1.14	29
12	1/2	7/8	5/8	-0814	7/8	22	<b>T2390-0814</b>	2.09	53	3.07	78	1.14	29
19	3/4	1.1/16	3/4	-1217	1.1/16	27	<b>T2390-1217</b>	2.36	60	3.50	89	1.18	30

**NOTE:** The "Live Swivel" T2390 Series Insert is for Maximum Working Pressure: 350 bar (5100 psi): -09 & -12 Thread Size, 280 bar (4100 psi): -14 & -17 Thread Size. Their swivel capability is to allow easy installation and orientation and avoid twisting of hose. They are not designed for continuous rotation or continuous movement.

**NOTE:** Hose Compatibility for the T2000 series can be found on page 187.

## T4000 SERIES ONE-PIECE CRIMP COUPLINGS

### HOSE COMPATIBILITY FOR T4000 SERIES

#### NON-SKIVE

For RYCO Hose Series SRF, SRX (sizes -12 to -48).  
 For RYCO Hose Series RT7/T/7N/7TN (sizes -02 to -12).  
 For RYCO Hose Series T5, RQP5 (sizes -04 to -32).  
 For RYCO Hose Series MP1 (sizes -04 to -20).  
 For RYCO Hose Series RST (sizes -08 to -48).  
 For RYCO Hose Series PCM (sizes -08 to -16).  
 For RYCO Hose Series M2/G, PL1/D (sizes -04 to -12).

#### NON-SKIVE

For RYCO Hose Series TP7, TP7N, TP7T, TP7TN, TP3000, PL1, PL1D, PL1PV, RQP6, CS1000, MS1000.

### BSP

### T4010

### T4013

60° SEAT

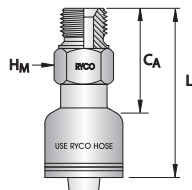
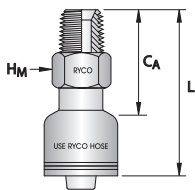

HOSE SIZE		THRD SIZE	DASH SIZE	MALE HEX	BSPT MALE				BSPP MALE						
DN	inch	inch		H <sub>M</sub> -SPANNER inch mm	PART NO	C <sub>A</sub> inch mm		L inch mm		PART NO	C <sub>A</sub> inch mm		L inch mm		
5	3/16	1/4	-0304	14	<b>T4010-0304</b>	1.14	29	1.93	49						
6	1/4	1/4	-0404	14	<b>T4010-0404</b>	1.26	32	2.24	57	<b>T4013-0404</b>	1.34	34	2.32	59	
8	5/16	1/4	-0504	14	<b>T4010-0504</b>	1.38	35	2.36	60						
10	3/8	1/4	-0604	14	<b>T4010-0604</b>	1.42	36	2.40	61						
10	3/8	3/8	-0606	3/4 19	<b>T4010-0606</b>	1.38	35	2.36	60	<b>T4013-0606</b>	1.46	37	2.44	62	
10	3/8	1/2	-0608	7/8 22	<b>T4010-0608</b>	1.61	41	2.60	66						
12	1/2	3/8	-0806	3/4 19	<b>T4010-0806</b>	1.50	38	2.48	63						
12	1/2	1/2	-0808	7/8 22	<b>T4010-0808</b>	1.65	42	2.64	67	<b>T4013-0808</b>	1.61	41	2.60	66	
16	5/8	3/4	-1012	1.1/16 27	<b>T4010-1012</b>	1.61	41	2.87	73						
19	3/4	3/4	-1212	1.1/16 27	<b>T4010-1212</b>	1.85	47	3.07	78	<b>T4013-1212</b>	1.85	47	3.07	78	
25	1	1	-1616	36	<b>T4010-1616</b>	2.09	53	3.39	86	<b>T4013-1616</b>	2.01	51	3.31	84	
31	1.1/4	1.1/4	-2020	46	<b>T4010-2020</b>	2.36	60	4.29	109	<b>T4013-2020</b>	2.36	60	4.29	109	
38	1.1/2	1.1/2	-2424	2 50	<b>T4010-2424</b>	2.17	55	4.13	105						
51	2	2	-3232	65	<b>T4010-3232</b>	2.60	66	4.69	119						

### BSPT

### T4320

60° SEAT

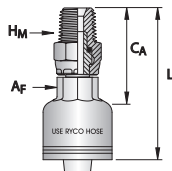

HOSE SIZE		THRD SIZE	DASH SIZE	BACK UP A <sub>F</sub>	MALE HEX	BSPT MALE SWIVEL				
DN	inch	inch		A <sub>F</sub> -SPANNER inch mm	H <sub>M</sub> -SPANNER inch mm	PART NO	C <sub>A</sub> inch mm		L inch mm	
4	1/8	1/8	-0202	1/2	14	<b>T4320-0202</b>	1.34	34	1.89	48

**NOTE:** This "Live Swivel" T4320 Series Insert is for Maximum Working Pressure: 420 bar (6100 psi): -02 Thread Size. Its swivel capability is to allow easy installation and orientation and avoid twisting of hose. It is not designed for continuous rotation or continuous movement.

INTRODUCTION

HOSE

COUPLINGS

ADAPTORS

TECHNICAL

# COUPLINGS

## T4000 SERIES ONE-PIECE CRIMP COUPLINGS

<b>BSPP</b>	<b>T4020</b>
-------------	--------------

60° SEAT

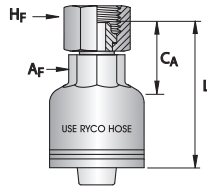

HOSE SIZE		THRD SIZE	DASH SIZE	BACK UP Af	FEMALE HEX		BSPP FEMALE					
DN	inch	inch		Af-SPANNER		Hf-SPANNER		PART NO	CA		L	
				inch	mm	inch	mm		inch	mm	inch	mm
5	3/16	1/4	-0304		12	3/4	19	<b>T4020-0304</b>	0.87	22	1.61	41
6	1/4	1/4	-0404		12	3/4	19	<b>T4020-0404</b>	0.91	23	1.89	48
8	5/16	1/4	-0504		14	3/4	19	<b>T4020-0504</b>	0.94	24	1.93	49
10	3/8	1/4	-0604	5/8	16	3/4	19	<b>T4020-0604</b>	0.94	24	1.93	49
10	3/8	3/8	-0606	5/8	16	7/8	22	<b>T4020-0606</b>	1.02	26	2.01	51
10	3/8	1/2	-0608	5/8	16	1.1/16	27	<b>T4020-0608</b>	1.18	30	2.13	54
12	1/2	1/2	-0808	3/4	19	1.1/16	27	<b>T4020-0808</b>	1.10	28	2.09	53
12	1/2	3/4	-0812	3/4	19	1.1/4	32	<b>T4020-0812</b>	1.26	32	2.28	58
16	5/8	5/8	-1010	7/8	22	1.3/16	30	<b>T4020-1010</b>	1.14	29	2.36	60
16	5/8	3/4	-1012	7/8	22	1.1/4	32	<b>T4020-1012</b>	1.30	33	2.52	64
19	3/4	3/4	-1212	1.1/16	27	1.1/4	32	<b>T4020-1212</b>	1.30	33	2.48	63
25	1	1	-1616	1.1/4	32	1.1/2	38	<b>T4020-1616</b>	1.50	38	2.80	71
31	1.1/4	1.1/4	-2020	1.5/8	41	2	50	<b>T4020-2020</b>	1.77	45	3.70	94
38	1.1/2	1.1/2	-2424	2	50	2.3/16	55	<b>T4020-2424</b>	1.85	47	3.78	96
51	2	2	-3232		65	2.3/4	70	<b>T4020-3232</b>	2.17	55	4.25	108

<b>BSPT</b>	<b>T4340</b>
-------------	--------------

60° SEAT

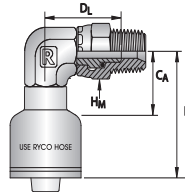

HOSE SIZE		THRD SIZE	DASH SIZE	MALE HEX	BSPT MALE SWIVEL 90° ELBOW							
DN	inch	inch		HM-SPANNER		PART NO	CA		L		DL	
				inch	mm		inch	mm	inch	mm	inch	mm
12	1/2	1/2	-0808	7/8	22	<b>T4340-0808</b>	1.46	37	2.48	63	2.05	52

**NOTE:** The "Live Swivel" T4340 Series Couplings is for Maximum Working Pressure: 420 bar (6100 psi): -04 & -06 Thread Size, 350 bar (5100 psi): -08 Thread Size, 280 bar (4100 psi): -12 Thread Size, 215 bar (3100 psi): -16 Thread Size. Their swivel capability is to allow easy installation and orientation and avoid twisting of hose. They are not designed for continuous rotation or continuous movement.

**NOTE:** Hose Compatibility for the T4000 series can be found on page 233.

## T4000 SERIES ONE-PIECE CRIMP COUPLINGS

<b>BSPP</b>	<b>T4050</b>	<b>T4260</b>
-------------	--------------	--------------

60° SEAT

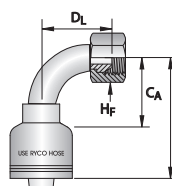
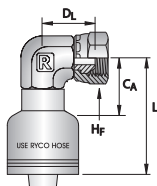

HOSE SIZE		THRD SIZE	DASH SIZE	FEMALE HEX		BSPP FEMALE 90° ELBOW						BSPP FEMALE 90° TUBE BEND							
DN	inch	inch		HF-SPANNER		PART NO	CA		L		DL		PART NO	CA		L		DL	
				inch	mm		inch	mm	inch	mm	inch	mm		inch	mm	inch	mm	inch	mm
6	1/4	1/4	-0404	3/4	19								<b>T4260-0404</b>	1.26	32	2.24	57	1.14	29
10	3/8	3/8	-0606	7/8	22								<b>T4260-0606</b>	1.38	35	2.32	59	1.30	33
10	3/8	1/2	-0608	1.1/16	27								<b>T4260-0608</b>	1.38	35	2.32	59	1.30	33
12	1/2	1/2	-0808	1.1/16	27	<b>T4050-0808</b>	1.46	37	2.48	63	1.22	31	<b>T4260-0808</b>	1.61	41	2.60	66	1.77	45
16	5/8	5/8	-1010	1.3/16	30								<b>T4260-1010</b>	1.77	45	3.03	77	1.97	50
19	3/4	3/4	-1212	1.1/4	32								<b>T4260-1212</b>	2.32	59	3.54	90	2.32	59
25	1	1	-1616	1.1/2	38								<b>T4260-1616</b>	2.68	68	4.02	102	3.07	78
31	1.1/4	1.1/4	-2020	2	50	<b>T4050-2020</b>	2.05	52	3.98	101	2.05	52							

INTRODUCTION

HOSE

COUPLINGS

ADAPTORS

TECHNICAL

**NOTE:** Hose Compatibility for the **T4000** series can be found on page 233.

# COUPLINGS

## T4000 SERIES ONE-PIECE CRIMP COUPLINGS

NPT	T4090	T4320N
-----	-------	--------

60° SEAT

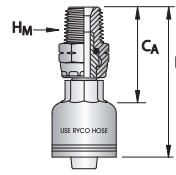
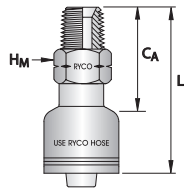

DN	HOSE SIZE		THRD SIZE	DASH SIZE	MALE HEX	NPT MALE				NPTF MALE SWIVEL						
	inch	inch			inch	mm	CA	L	Part No	CA	L	Part No	CA	L		
4	1/8	1/8	-0202		1/2		T4090-0202	0.79	20	1.34	34	T4320N-0202	1.34	34	1.89	48
5	3/16	1/8	-0302		1/2		T4090-0302	0.91	23	1.69	43					
5	3/16	1/4	-0304		9/16		T4090-0304	1.14	29	1.93	49					
6	1/4	1/8	-0402		1/2		T4090-0402	1.10	28	2.13	54					
6	1/4	1/4	-0404		9/16		T4090-0404	1.26	32	2.24	57					
8	5/16	1/4	-0504		9/16		T4090-0504	1.34	34	2.32	59					
8	5/16	3/8	-0506		3/4	19	T4090-0506	1.34	34	2.32	59					
10	3/8	1/4	-0604		9/16		T4090-0604	1.38	35	2.36	60					
10	3/8	3/8	-0606		3/4	19	T4090-0606	1.38	35	2.36	60					
10	3/8	1/2	-0608		7/8	22	T4090-0608	1.61	41	2.60	66					
12	1/2	3/8	-0806		3/4	19	T4090-0806	1.50	38	2.48	63	T4320N-0806	1.97	50	2.95	75
12	1/2	1/2	-0808		7/8	22	T4090-0808	1.65	42	2.64	67					
12	1/2	3/4	-0812		1.1/16	27	T4090-0812	1.73	44	2.72	69					
16	5/8	3/4	-1012		1.1/16	27	T4090-1012	1.61	41	2.87	73					
19	3/4	3/4	-1212		1.1/16	27	T4090-1212	1.85	47	3.07	78					
22	7/8	1	-1416		1.3/8		T4090-1416	1.69	43	2.91	74					
25	1	1	-1616		1.3/8		T4090-1616	2.09	53	3.39	86					
28	1.1/8	1.1/4	-1820		1.3/4		T4090-1820	1.81	46	3.11	79					
31	1.1/4	1	-2016		1.3/8		T4090-2016	2.28	58	4.21	107					
31	1.1/4	1.1/4	-2020		1.3/4		T4090-2020	2.36	60	4.29	109					
35	1.3/8	1.1/2	-2224		2	50	T4090-2224	2.13	54	3.98	101					
38	1.1/2	1.1/2	-2424		2	50	T4090-2424	2.17	55	4.13	105					
46	1.13/16	2	-2932		2.1/2		T4090-2932	2.32	59	4.41	112					
51	2	2	-3232		2.1/2		T4090-3232	2.60	66	4.69	119					

**NOTE:** The "Live Swivel" T4320N Series Coupling is for Maximum Working Pressure: 420 bar (6100 psi): -04 & -06 Thread Size, 350 bar (5100 psi): -08 Thread Size, 280 bar (4100 psi): -12 Thread Size, 215 bar (3100 psi): -16 Thread Size. Their swivel capability is to allow easy installation and orientation and avoid twisting of hose. They are not designed for continuous rotation or continuous movement.

NPT	T4020N
-----	--------

60° SEAT

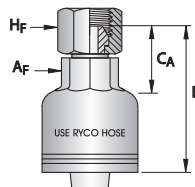

DN	HOSE SIZE		THRD SIZE	DASH SIZE	BACK UP A <sub>F</sub>	FEMALE HEX	NPSM FEMALE						
	inch	inch			inch	mm	A <sub>F</sub> -SPANNER	H <sub>F</sub> -SPANNER	Part No	CA	L		
6	1/4	1/4	-0404		1/2		11/16		T4020N-0404	0.91	23	1.89	48
10	3/8	3/8	-0606		5/8	16	7/8	22	T4020N-0606	1.02	26	2.01	51
12	1/2	1/2	-0808		3/4	19	1.1/16	27	T4020N-0808	1.10	28	2.09	53



## T4000 SERIES ONE-PIECE CRIMP COUPLINGS

JIC - MALE	T4030 - T4031
------------	---------------

37° FLARE

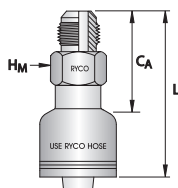

DN	HOSE SIZE		THRD SIZE	TUBE SIZE	DASH SIZE	MALE HEX		JIC MALE					
	inch	inch	inch	inch	inch	inch	mm	HM-SPANNER	PART NO	CA		L	
	inch	inch	inch	inch	inch	inch	mm	inch	mm	inch	mm	inch	mm
5	3/16	7/16	1/4	-0307	1/2				<b>T4030-0307</b>	1.06	27	1.85	47
6	1/4	7/16	1/4	-0407	1/2				<b>T4030-0407</b>	1.26	32	2.28	58
						12		<b>T4031-0407</b>					
6	1/4	1/2	5/16	-0408	9/16				<b>T4030-0408</b>	1.22	31	2.24	57
6	1/4	9/16	3/8	-0409	5/8	16			<b>T4030-0409</b>	1.26	32	2.24	57
10	3/8	9/16	3/8	-0609	5/8	16			<b>T4030-0609</b>	1.42	36	2.40	61
10	3/8	3/4	1/2	-0612	3/4	19			<b>T4030-0612</b>	1.46	37	2.44	62
12	1/2	3/4	1/2	-0812	3/4	19			<b>T4030-0812</b>	1.57	40	2.56	65
12	1/2	7/8	5/8	-0814	15/16	24			<b>T4030-0814</b>	1.69	43	2.68	68
16	5/8	7/8	5/8	-1014	15/16	24			<b>T4030-1014</b>	1.69	43	2.95	75
16	5/8	1.1/16	3/4	-1017	1.1/16	27			<b>T4030-1017</b>	1.69	43	2.95	75
19	3/4	1.1/16	3/4	-1217	1.1/16	27			<b>T4030-1217</b>	1.97	50	3.19	81
38	1.1/2	1.7/8	1.1/2	-2430	2	50			<b>T4030-2430</b>	2.24	57	4.17	106

**NOTE:** Hose Compatibility for the **T4000** series can be found on page 233.

INTRODUCTION

HOSE

COUPLINGS

ADAPTORS

TECHNICAL

# COUPLINGS

## T4000 SERIES ONE-PIECE CRIMP COUPLINGS

JSEAL™ / JIC

T4040 - T4041

CONVEX SEAT

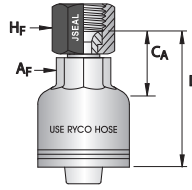

DN	HOSE SIZE	THRD SIZE	TUBE SIZE	DASH SIZE	BACK UP Af		FEMALE HEX		PART NO	JSEAL™ / JIC FEMALE CA		L	
					inch	mm	inch	mm		inch	mm	inch	mm
5	3/16	7/16	1/4	-0307	1/2		9/16		T4040-0307	0.87	22	1.61	41
							14		T4041-0307				
5	3/16	1/2	5/16	-0308	1/2		5/8	16	T4040-0308	0.87	22	1.61	41
							9/16		T4040-0309				
5	3/16	9/16	3/8	-0309			11/16		T4040-0309	0.87	22	1.65	42
							3/4	19	T4041-0309				
6	1/4	3/8	3/16	-0406	1/2		1/2		T4040-0406	0.87	22	1.85	47
6	1/4	7/16	1/4	-0407	1/2		9/16		T4040-0407	0.75	19	1.73	44
							12	14	T4041-0407				
6	1/4	1/2	5/16	-0408	1/2		5/8	16	T4040-0408	0.83	21	1.81	46
							11/16		T4040-0409				
6	1/4	9/16	3/8	-0409			11/16		T4040-0409	0.87	22	1.89	48
							12	3/4	19				
8	5/16	1/2	5/16	-0508		14	5/8	16	T4040-0508	0.87	22	1.85	47
							14	11/16					
8	5/16	9/16	3/8	-0509		14	3/4	19	T4041-0509	0.87	22	1.89	48
							14	3/4	19				
8	5/16	3/4	1/2	-0512		14	7/8	22	T4040-0512	0.87	22	1.85	47
							14	7/8	22				
10	3/8	7/16	1/4	-0607	5/8	16	9/16		T4040-0607	0.87	22	1.85	47
							5/8	16	14				
10	3/8	9/16	3/8	-0609	5/8	16	11/16		T4040-0609	1.69	43	2.68	68
							5/8	16	3/4				
10	3/8	3/4	1/2	-0612	5/8	16	7/8	22	T4040-0612	1.06	27	2.05	52
							5/8	16	7/8				
12	1/2	9/16	3/8	-0809	3/4	19	11/16		T4040-0809	1.22	31	2.20	56
							19	3/4	19				
12	1/2	3/4	1/2	-0812	3/4	19	7/8	22	T4040-0812	1.18	30	2.44	62
12	1/2	7/8	5/8	-0814	3/4	19	1.1/16	27	T4040-0814	1.34	34	2.52	64
12	1/2	1.1/16	3/4	-0817	3/4	19	1.1/4	32	T4040-0817	1.22	31	2.44	62
16	5/8	7/8	5/8	-1014	7/8	22	1.1/16	27	T4040-1014	1.34	34	2.56	65
							7/8	22	1.1/4				
19	3/4	7/8	5/8	-1214	1.1/16	27	1.1/16	27	T4040-1214	1.38	35	2.72	69
							1.1/16	27	1.1/4				
22	7/8	1.5/16	1	-1421	1.1/4	32	1.1/2	38	T4040-1421	1.69	43	3.62	92
25	1	1.1/16	3/4	-1617	1.1/4	32	1.1/4	32	T4040-1617	1.69	43	3.62	92
25	1	1.5/16	1	-1621	1.1/4	32	1.1/2	38	T4040-1621	1.73	44	3.58	91
28	1.1/18	1.5/8	1.1/4	-1826	1.5/8	41	2	50	T4040-1826	2.09	53	4.06	103
31	1.1/4	1.5/16	1	-2021	1.5/8	41	1.1/2	38	T4040-2021	2.36	60	4.45	113
31	1.1/4	1.5/8	1.1/4	-2026	1.5/8	41	2	50	T4040-2026	2.44	62	4.49	114
35	1.3/8	1.7/8	1.1/2	-2230	2		2.1/4	57	T4040-2230	1.73	44	3.58	91
38	1.1/2	1.7/8	1.1/2	-2430	2	50	2.1/4	57	T4040-2430	2.09	53	4.06	103
46	1.13/16	2.1/2	2	-2940	2.1/2		2.7/8	73	T4040-2940	2.36	60	4.45	113
51	2	2.1/2	2	-3240		65	2.7/8	73	T4040-3240	2.44	62	4.49	114

**NOTE:** Hose Compatibility for the T4000 series can be found on page 233.

## T4000 SERIES ONE-PIECE CRIMP COUPLINGS

JSEAL™ / JIC	T4250 - T4251
--------------	---------------

CONVEX SEAT

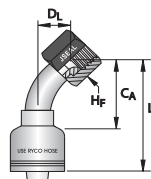

DN	HOSE SIZE				FEMALE HEX		PART NO	CA		L		DL	
	inch	inch	inch	DASH SIZE	inch	mm		inch	mm	inch	mm	inch	mm
5	3/16	7/16	1/4	-0307	9/16		T4250-0307	1.22	31	1.97	50	0.39	10
						14	T4251-0307						
6	1/4	7/16	1/4	-0407	9/16		T4250-0407	1.57	40	2.56	65	0.59	15
						14	T4251-0407						
6	1/4	1/2	5/16	-0408	5/8	16	T4250-0408	1.30	33	2.28	58	0.59	15
6	1/4	9/16	3/8	-0409	11/16		T4250-0409	1.30	33	2.28	58	0.59	15
						19	T4251-0409						
8	5/16	9/16	3/8	-0509	11/16		T4250-0509	1.57	40	2.56	65	0.63	16
						19	T4251-0509						
16	5/8	1.1/16	3/4	-1017	1.1/4	32	T4250-1017	2.13	54	3.39	86	0.94	24
19	3/4	1.1/16	3/4	-1217	1.1/4	32	T4250-1217	3.11	79	4.29	109	1.10	28
25	1	1.5/16	1	-1621	1.1/2	38	T4250-1621	3.31	84	4.65	118	1.38	35
31	1.1/4	1.5/8	1.1/4	-2026	2	50	T4250-2026	3.94	100	5.87	149	1.54	39

**NOTE:** Hose Compatibility for the T4000 series can be found on page 233.

INTRODUCTION

HOSE

COUPLINGS

ADAPTORS

TECHNICAL

# COUPLINGS

## T4000 SERIES ONE-PIECE CRIMP COUPLINGS

JSEAL™ / JIC	T4243	T4240 - T4241
--------------	-------	---------------

CONVEX SEAT

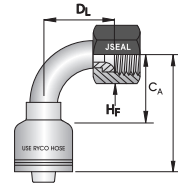
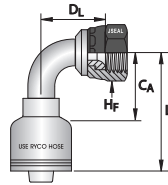

HOSE SIZE	THRD SIZE	TUBE SIZE	DASH SIZE	FEMALE HEX	JSEAL™ / JIC FEMALE 90° SHORT BEND						JSEAL™ JIC FEMALE 90° MEDIUM BEND									
					HF-SPANNER	PART NO	CA	L	DL	PART NO	CA	L	DL							
DN	inch	inch	inch		inch	mm	inch	mm	inch	mm	inch	mm	inch	mm	inch	mm				
5	3/16	7/16	1/4		9/16								<b>T4240-0307</b>	1.06	27	1.85	47	0.98	25	
6	1/4	7/16	1/4	-0407	9/16		<b>T4243-0407</b>	1.46	37	2.44	62	0.83	21	<b>T4240-0407</b>	1.54	39	2.52	64	1.26	32
					14	<b>T4241-0407</b>														
6	1/4	1/2	5/16	-0408	5/8	16							<b>T4240-0408</b>	1.26	32	2.24	57	1.26	32	
6	1/4	9/16	3/8	-0409	11/16		<b>T4243-0409</b>	1.06	27	2.05	52	0.87	22	<b>T4240-0409</b>	1.30	33	2.28	58	1.50	38
					3/4	<b>T4241-0409</b>														
8	5/16	9/16	3/8	-0509	11/16		<b>T4243-0609</b>	1.22	31	2.20	56	0.91	23	<b>T4240-0509</b>	1.38	35	2.36	60	1.18	30
					3/4	<b>T4241-0509</b>														
10	3/8	9/16	3/8	-0609	11/16		<b>T4243-0609</b>	1.22	31	2.20	56	0.91	23	<b>T4240-0609</b>	1.34	34	2.32	59	1.02	26
					3/4	<b>T4241-0609</b>														
10	3/8	3/4	1/2	-0612	7/8	22								<b>T4240-0612</b>	1.38	35	2.36	60	1.18	30
12	1/2	3/4	1/2	-0812	7/8	22	<b>T4243-0812</b>	1.69	43	2.68	68	1.14	29	<b>T4240-0812</b>	1.61	41	2.60	66	1.50	38
12	1/2	7/8	5/8	-0814	1.1/16	27								<b>T4240-0814</b>	1.61	41	2.60	66	1.61	41
16	5/8	1.1/16	3/4	-1017	1.1/4	32								<b>T4240-1017</b>	1.77	45	3.03	77	1.89	48
19	3/4	1.1/16	3/4	-1217	1.1/4	32								<b>T4240-1217</b>	2.32	59	3.54	90	2.24	57
25	1	1.5/16	1	-1621	1.1/2	38								<b>T4240-1621</b>	2.68	68	3.98	101	2.83	72
28	1.1/18	1.5/8	1.1/4	-1826	2	50								<b>T4240-1826</b>	2.68	68	4.02	102	3.07	78
31	1.1/4	1.5/16	1	-2021	1.1/2	38								<b>T4240-2021</b>	3.54	90	5.47	139	2.83	72
31	1.1/4	1.5/8	1.1/4	-2026	2	50								<b>T4240-2026</b>	3.94	100	5.87	149	3.19	81
38	1.1/2	1.7/8	1.1/2	-2430	2.1/4	57								<b>T4240-2430</b>	4.17	106	6.10	155	4.17	106
51	2	2.1/2	2	-3240	2.7/8	73								<b>T4240-3240</b>	5.83	148	7.91	201	5.20	132

JSEAL™ / JIC	T4280 - T4281
--------------	---------------

CONVEX SEAT

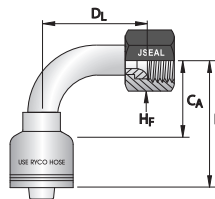

HOSE SIZE	THRD SIZE	TUBE SIZE	DASH SIZE	FEMALE HEX	JSEAL™ / JIC FEMALE 90° LONG BEND								
					HF-SPANNER	PART NO	CA	L	DL				
DN	inch	inch	inch		inch	mm	inch	mm	inch	mm			
8	5/16	9/16	3/8	-0509	11/16		<b>T4280-0509</b>	2.05	52	3.03	77	2.17	55
					3/4	19							
10	3/8	9/16	3/8	-0609	11/16		<b>T4280-0609</b>	2.05	52	2.99	76	2.17	55
					3/4	19							
10	3/8	3/4	1/2	-0612	7/8	22	<b>T4280-0612</b>	2.05	52	2.99	76	2.52	64

**NOTE:** Hose Compatibility for the T4000 series can be found on page 233.

## T4000 SERIES ONE-PIECE CRIMP COUPLINGS

### JIS - BSP T4122

**JAPANESE INDUSTRIAL  
STANDARD (JIS)  
BSPP THREAD FORM  
60° CONCAVE SEAT**

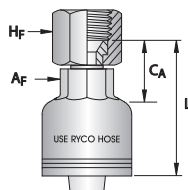

HOSE SIZE		THRD SIZE	DASH SIZE	BACK UP Af	FEMALE HEX		BSPP FEMALE 60° CONCAVE (JIS)					
DN	inch	inch		Af-SPANNER		Hf-SPANNER		PART NO	CA		L	
				inch	mm	inch	mm		inch	mm	inch	mm
6	1/4	1/4	-0404		12	3/4	19	<b>T4122-0404</b>	0.79	20	1.77	45
10	3/8	3/8	-0606	5/8	16	7/8	22	<b>T4122-0606</b>	0.98	25	1.97	50
10	3/8	1/2	-0608	5/8	16	1.1/16	27	<b>T4122-0608</b>	1.06	27	2.05	52
12	1/2	1/2	-0808	3/4	19	1.1/16	27	<b>T4122-0808</b>	0.98	25	1.97	50
19	3/4	3/4	-1212	1.1/16	27		36	<b>T4122-1212</b>	1.22	31	2.44	62
25	1	1	-1616	1.1/4	32	1.5/8	41	<b>T4122-1616</b>	1.38	35	2.72	69

### METRIC - DKL T4600 T4660

**DKL  
METRIC (LIGHT)  
RYCO DKL FEMALE SWIVELS  
UP TO M26 SIZE HAVE MULTISEAL DKL 24° AND  
DKM 60° CONE. M30 AND OVER HAVE DKL 24°  
CONE ONLY.**

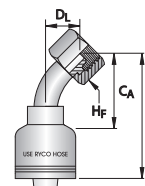
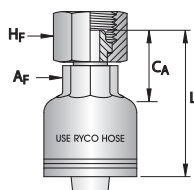

HOSE SIZE		THRD SIZE	TUBE SIZE	DASH SIZE	BACK UP Af	FEMALE HEX		DKL FEMALE 24°/60° CONE				DKL FEMALE 24°/60° CONE 45° TUBE BEND								
DN	inch	mm	mm		Af-SPANNER		Hf-SPANNER		PART NO	CA		L		PART NO	CA		L		DL	
					inch	mm	inch	mm		inch	mm	inch	mm		inch	mm	inch	mm	inch	mm
10	3/8	16x1,5	10	-0616	5/8	16	3/4	19	<b>T4600-0616</b>	1.14	29	2.13	54	<b>T4660-0616</b>	1.77	45	2.76	70	0.79	20
10	3/8	18x1,5	12	-0618	5/8	16	7/8	22	<b>T4600-0618</b>	1.18	30	2.17	55	<b>T4660-0618</b>	1.77	45	2.76	70	0.79	20
10	3/8	22x1,5	15	-0622	5/8	16	1.1/16	27	<b>T4600-0622</b>	1.26	32	2.24	57	<b>T4660-0622</b>	1.81	46	2.80	71	0.83	21
19	3/4	30x2,0	22	-1230	1.1/16	27		36	<b>T4600-1230</b>	1.50	38	2.72	69	<b>T4660-1230</b>	2.87	73	4.09	104	1.26	32

**NOTE:** Hose Compatibility for the **T4000** series can be found on page 233.



# COUPLINGS

## T4000 SERIES ONE-PIECE CRIMP COUPLINGS

### METRIC - DKL

### T4670

DKL  
METRIC (LIGHT)  
RYCO DKL FEMALE SWIVELS  
UP TO M26 SIZE HAVE MULTISEAL DKL  
24° AND DKM 60° CONE. M30 AND OVER  
HAVE DKL 24° CONE ONLY.

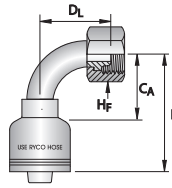

HOSE SIZE		THRD SIZE	TUBE SIZE	DASH SIZE	FEMALE HEX		PART NO	DKL FEMALE 24°/60° CONE		90° TUBE BEND		D_L	
DN	inch	mm	mm		inch	mm		inch	mm	inch	mm	inch	mm
10	3/8	16x1,5	10	-0616	3/4	19	<b>T4670-0616</b>	1.38	35	2.36	60	1.38	35
10	3/8	18x1,5	12	-0618	7/8	22	<b>T4670-0618</b>	1.38	35	2.36	60	1.38	35
10	3/8	22x1,5	15	-0622	1.1/16	27	<b>T4670-0622</b>	1.38	35	2.36	60	1.46	37
19	3/4	30x2,0	22	-1230		36	<b>T4670-1230</b>	2.32	59	3.54	90	2.52	64

### METRIC - DKOL

### T4501

DKOL  
24° CONE

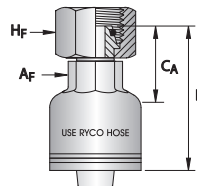

HOSE SIZE		THRD SIZE	TUBE SIZE	DASH SIZE	BACK UP A_F		FEMALE HEX		PART NO	DKOL FEMALE 24° CONE		L	
DN	inch	mm	mm		inch	mm	inch	mm		inch	mm	inch	mm
12	1/2	22x1,5	15	-0822	3/4	19	1.1/16	27	<b>T4501-0822</b>	1.26	32	2.24	57
16	5/8	18x1,5	12	-1018	7/8	22	7/8	22	<b>T4501-1018</b>	2.68	68	3.90	99
16	5/8	30x2,0	22	-1030	7/8	22		36	<b>T4501-1030</b>	1.42	36	2.64	67

**NOTE:** Hose Compatibility for the **T4000** series can be found on page 233.

## T4000 SERIES ONE-PIECE CRIMP COUPLINGS

### ORFS T4840

O RING  
FACE SEAL

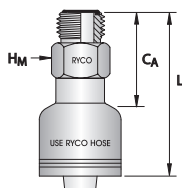

DN	HOSE SIZE		THRD SIZE	TUBE SIZE	DASH SIZE	MALE HEX		PART NO	CA		L	
	inch	inch	inch	inch	inch	inch	mm		inch	mm	inch	mm
6	1/4	9/16	1/4	-0409	5/8	16		<b>T4840-0409</b>	1.22	31	2.24	57
6	1/4	11/16	3/8	-0411	3/4	19		<b>T4840-0411</b>	1.30	33	2.28	58
8	5/16	13/16	1/2	-0513	7/8	22		<b>T4840-0513</b>	1.38	35	2.40	61
10	3/8	11/16	3/8	-0611	3/4	19		<b>T4840-0611</b>	1.34	34	2.32	59
10	3/8	13/16	1/2	-0613	7/8	22		<b>T4840-0613</b>	1.46	37	2.44	62
12	1/2	13/16	1/2	-0813	7/8	22		<b>T4840-0813</b>	1.50	38	2.48	63
16	5/8	1	5/8	-1016	1.1/16	27		<b>T4840-1016</b>	1.57	40	2.80	71
19	3/4	1.3/16	3/4	-1219	1.1/4	32		<b>T4840-1219</b>	1.85	47	3.07	78
19	3/4	1.7/16	1	-1223	1.1/2	38		<b>T4840-1223</b>	2.05	52	3.23	82
25	1	1.7/16	1	-1623	1.1/2	38		<b>T4840-1623</b>	2.01	51	3.35	85
28	1.1/8	1.3/16	3/4	-1819	1.3/8			<b>T4840-1819</b>	1.26	32	2.60	66
31	1.1/4	1.11/16	1.1/4	-2027	2	50		<b>T4840-2027</b>	2.28	58	4.21	107

### ORFS T4800 - T4801

O RING  
FACE SEAL

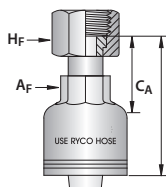

DN	HOSE SIZE		THRD SIZE	DASH SIZE	BACK UP Af		FEMALE HEX		PART NO	CA		L	
	inch	inch	inch	inch	inch	mm	inch	mm		inch	mm	inch	mm
6	1/4	9/16	-0409	1/2	12	17	11/16	17	<b>T4800-0409</b>	1.14	29	2.17	55
									<b>T4801-0409</b>				
6	1/4	11/16	-0411	1/2	12	22	7/8	22	<b>T4800-0411</b>	1.22	31	2.20	56
									<b>T4801-0411</b>				
10	3/8	11/16	-0611	5/8	16	7/8	22		<b>T4800-0611</b>	1.26	32	2.24	57
10	3/8	13/16	-0613	5/8	16	15/16	24		<b>T4800-0613</b>	1.38	35	2.36	60
12	1/2	13/16	-0813	3/4	19	15/16	24		<b>T4800-0813</b>	1.42	36	2.40	61
19	3/4	1.3/16	-1219	1.1/16	27	1.3/8			<b>T4800-1219</b>	1.65	42	2.87	73
									<b>T4801-1219</b>				
19	3/4	1.7/16	-1223	1.1/16	27	1.5/8	41		<b>T4800-1223</b>	1.65	42	2.83	72
25	1	1.3/16	-1619	1.1/4	32	1.3/8			<b>T4800-1619</b>	1.61	41	2.95	75
									<b>T4801-1619</b>				
25	1	1.7/16	-1623	1.1/4	32	1.5/8	41		<b>T4800-1623</b>	1.61	41	2.95	75
31	1.1/4	1.11/16	-2027	1.5/8	41	2	50		<b>T4800-2027</b>	1.89	48	3.82	97

**NOTE:** Hose Compatibility for the T4000 series can be found on page 233.

# COUPLINGS

## T4000 SERIES ONE-PIECE CRIMP COUPLINGS

<b>ORFS</b>	<b>T4810 - T4811</b>	<b>T4820 - T4821</b>
-------------	----------------------	----------------------

O RING  
FACE SEAL

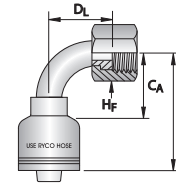
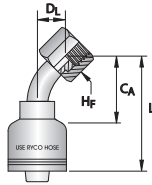

HOSE SIZE		THRD SIZE	DASH SIZE	FEMALE HEX		ORFS FEMALE 45° TUBE BEND						ORFS FEMALE 90° MEDIUM BEND							
DN	inch	inch		HF-SPANNER		PART NO	CA		L		DL		PART NO	CA		L		DL	
				inch	mm		inch	mm	inch	mm	inch	mm		inch	mm	inch	mm	inch	mm
6	1/4	9/16	-0409	11/16		<b>T4810-0409</b>	1.54	39	2.52	64	0.71	18	<b>T4820-0409</b>	1.30	33	2.28	58	1.26	32
					17	<b>T4811-0409</b>							<b>T4821-0409</b>						
6	1/4	11/16	-0411	7/8	22								<b>T4820-0411</b>	1.30	33	2.28	58	1.50	38
10	3/8	11/16	-0611	7/8	22	<b>T4810-0611</b>	1.77	45	2.72	69	0.79	20	<b>T4820-0611</b>	1.38	35	2.36	60	1.50	38
10	3/8	13/16	-0613	15/16	24	<b>T4810-0613</b>	1.57	40	2.56	65	0.67	17	<b>T4820-0613</b>	1.50	38	2.48	63	1.34	34
12	1/2	13/16	-0813	15/16	24	<b>T4810-0813</b>	1.93	49	2.91	74	0.75	19	<b>T4820-0813</b>	1.61	41	2.60	66	1.61	41
16	5/8	1	-1016	1.1/8		<b>T4810-1016</b>	2.32	59	3.58	91	0.79	20	<b>T4821-1016</b>						
				1.3/16	30	<b>T4811-1016</b>							<b>T4821-1016</b>						
19	3/4	1.3/16	-1219	1.3/8		<b>T4810-1219</b>	3.11	79	4.29	109	1.14	29	<b>T4820-1219</b>	2.32	59	3.54	90	2.32	59
					36	<b>T4811-1219</b>							<b>T4821-1219</b>						
25	1	1.3/16	-1619	1.3/8									<b>T4820-1619</b>	2.72	69	4.06	103	2.32	59
25	1	1.7/16	-1623	1.5/8	41	<b>T4810-1623</b>	3.39	86	4.72	120	1.34	34	<b>T4820-1623</b>	2.72	69	4.06	103	2.80	71
31	1.1/4	1.11/16	-2027	2	50	<b>T4810-2027</b>	4.02	102	5.94	151	1.77	45	<b>T4820-2027</b>	3.94	100	5.87	149	3.54	90
38	1.1/2	2	-2432	2.1/4	57								<b>T4820-2432</b>	4.17	106	6.10	155	4.21	107

<b>ORFS</b>	<b>T4830</b>
-------------	--------------

O RING  
FACE SEAL

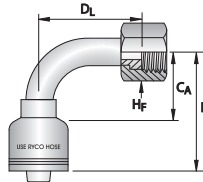

HOSE SIZE		THRD SIZE	TUBE SIZE	DASH SIZE	FEMALE HEX		ORFS FEMALE 90° LONG BEND						
DN	inch	inch	inch		HF-SPANNER		PART NO	CA		L		DL	
					inch	mm		inch	mm	inch	mm	inch	mm
25	1	1.7/16	1	-1623	1.5/8	41	<b>T4830-1623</b>	2.91	74	4.25	108	4.45	113

**NOTE:** Hose Compatibility for the **T4000** series can be found on page 233.

## T4000 SERIES ONE-PIECE CRIMP COUPLINGS

### SAE T4530

45° FLARE

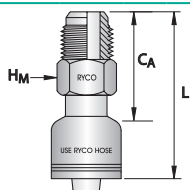

HOSE SIZE		THRD SIZE	TUBE SIZE	DASH SIZE	MALE HEX		SAE MALE					
DN	inch	inch	inch		HM-SPANNER		PART NO		CA		L	
	inch	inch	inch		inch	mm			inch	mm	inch	mm
8	5/16	5/8	3/8	-0510	5/8	16	<b>T4530-0510</b>		1.34	34	2.32	59
10	3/8	5/8	3/8	-0610	5/8	16	<b>T4530-0610</b>		1.46	37	2.44	62

### SAE T4540

45° FLARE

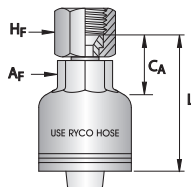

HOSE SIZE		THRD SIZE	TUBE SIZE	DASH SIZE	BACK UP Af		FEMALE HEX		SAE FEMALE					
DN	inch	inch	inch		Af-SPANNER		Hf-SPANNER		PART NO		CA		L	
	inch	inch	inch		inch	mm	inch	mm			inch	mm	inch	mm
6	1/4	5/8	3/8	-0410		12	3/4	19	<b>T4540-0410</b>		1.14	29	2.17	55
8	5/16	5/8	3/8	-0510		14	3/4	19	<b>T4540-0510</b>		1.14	29	2.17	55
10	3/8	5/8	3/8	-0610	5/8	16	3/4	19	<b>T4540-0610</b>		1.22	31	2.20	56

### SAE T4570 T4550

45° FLARE

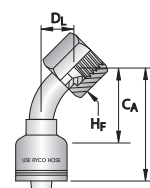
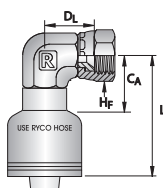

HOSE SIZE		THRD SIZE	TUBE SIZE	DASH SIZE	FEMALE HEX		SAE FEMALE 90° ELBOW						SAE FEMALE 45° TUBE BEND									
DN	inch	inch	inch		Hf-SPANNER		PART NO		CA		L		DL		PART NO		CA		L		DL	
	inch	inch	inch		inch	mm			inch	mm	inch	mm	inch	mm	inch	mm	inch	mm	inch	mm	inch	mm
8	5/16	5/8	3/8	-0510	3/4	19										<b>T4550-0510</b>	1.54	39	2.52	64	0.59	15
10	3/8	5/8	3/8	-0610	3/4	19	<b>T4570-0610</b>		1.22	31	2.20	56	0.91	23	<b>T4550-0610</b>	1.54	39	2.52	64	0.67	17	

**NOTE:** Hose Compatibility for the T4000 series can be found on page 233.

INTRODUCTION

HOSE

COUPLINGS

ADAPTORS

TECHNICAL

# COUPLINGS

## T4000 SERIES ONE-PIECE CRIMP COUPLINGS

SAE	T4560
-----	-------

45° FLARE

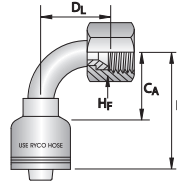

HOSE SIZE	THRD SIZE	TUBE SIZE	DASH SIZE	FEMALE HEX		SAE FEMALE 90° TUBE BEND							
				HF-SPANNER	PART NO	CA		L		DL			
DN	inch	inch	inch	inch	mm	inch	mm	inch	mm	inch	mm	inch	mm
10	3/8	5/8	3/8	-0610	3/4	19	<b>T4560-0610</b>	1.38	35	2.36	60	1.26	32

SAE	T4740	T4750
-----	-------	-------

INVERTED MALE FLARE

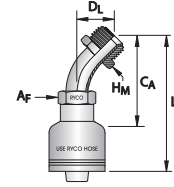
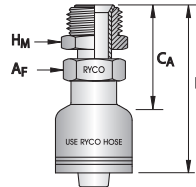

HOSE SIZE	THRD SIZE	TUBE SIZE	DASH SIZE	BACK UP AF	MALE HEX		SAE INVERTED MALE FLARE				SAE INVERTED MALE FLARE 45° TUBE BEND									
					AF-SPANNER	HM-SPANNER	PART NO		CA		L		PART NO		CA		L		DL	
DN	inch	inch	inch	inch	inch	mm	inch	mm	inch	mm	inch	mm	inch	mm	inch	mm	inch	mm		
8	5/16	5/8	3/8	-0510	5/8	16	5/8	16						<b>T4750-0510</b>	3.15	80	4.13	105	0.91	23
10	3/8	5/8	3/8	-0610	5/8	16	5/8	16	<b>T4740-0610</b>	1.61	41	2.60	66	<b>T4750-0610</b>	3.19	81	4.17	106	0.91	23
10	3/8	11/16	7/16	-0611	5/8	16	11/16		<b>T4740-0611</b>	2.05	52	3.03	77							

SAE	T4770
-----	-------

INVERTED MALE FLARE

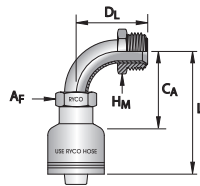

HOSE SIZE	THRD SIZE	TUBE SIZE	DASH SIZE	BACK UP AF	MALE HEX		SAE INVERTED MALE FLARE 90° TUBE BEND								
					AF-SPANNER	HM-SPANNER	PART NO		CA		L		DL		
DN	inch	inch	inch	inch	inch	mm	inch	mm	inch	mm	inch	mm	inch	mm	
8	5/16	5/8	3/8	-0510	5/8	16	5/8	16	<b>T4770-0510</b>	2.48	63	3.50	89	1.97	50
10	3/8	5/8	3/8	-0610	5/8	16	5/8	16	<b>T4770-0610</b>	2.48	63	3.46	88	1.97	50

**NOTE:** Hose Compatibility for the **T4000** series can be found on page 233.

## T4000 SERIES ONE-PIECE CRIMP COUPLINGS

### DIMENSIONS FOR SAE CODE 61 AND CODE 62 FLANGES, AND RYCO CODE 62C FLANGES

NOMINAL FLANGE	CODE 61				CODE 62				CODE 62C			
	B		T		B		T		B		T	
inch	mm	inch	mm	inch	mm	inch	mm	inch	mm	inch	mm	inch
1/2	30,2	1.19	6,73	0.265	31,8	1.25	7,75	0.305				
5/8	34,0	1.34	6,73	0.265								
3/4	38,1	1.50	6,73	0.265	41,3	1.63	8,76	0.345	41,3	1.63	14,20	0.559
1	44,5	1.75	8,00	0.315	47,6	1.88	9,53	0.375	47,6	1.88	14,20	0.559
1.1/4	50,8	2.00	8,00	0.315	54,0	2.12	10,29	0.405	54,0	2.12	14,20	0.559
1.1/2	60,3	2.38	8,00	0.315	63,5	2.50	12,57	0.495	63,5	2.50	14,20	0.559
2	71,4	2.81	9,53	0.375	79,4	3.13	12,57	0.495	79,4	3.13	14,20	0.559
2.1/2	84,1	3.31	9,53	0.375								
3	101,6	4.00	9,53	0.375								

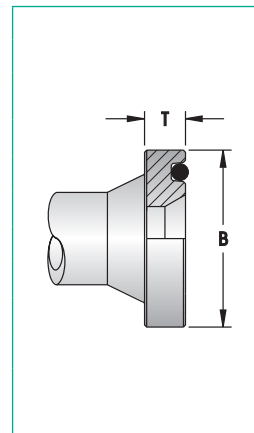

INTRODUCTION

HOSE

COUPLINGS

ADAPTORS

TECHNICAL

**NOTE:** RYCO Code 62C fittings conform to the flange OD and bolt hole patterns of SAE Code 62 but require special flange clamps. RYCO Code 62C flange heads are thicker than SAE Code 62 and measure T = 14,2 mm (0.559 inch) in all sizes.

#### RYCOLOK MALE

#### T4870

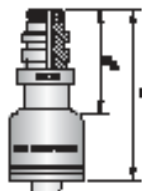

HOSE SIZE		TUBE SIZE	DASH SIZE	RYCOLOK MALE				
DN	inch	inch		PART NO	CA		L	
					inch	mm	inch	mm
51	2	50	-3250	<b>T4870-3250</b>	2.28	58	4.33	110

**NOTE:** Hose Compatibility for the **T4000** series can be found on page 233.



# COUPLINGS

## T4000 SERIES ONE-PIECE CRIMP COUPLINGS

SAE FLANGE	T4130	T4150
------------	-------	-------

RYCO  
CODE 61  
CLAMPS - SEE PAGES  
440 & 441  
O RING NOT SUPPLIED

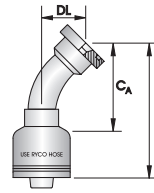
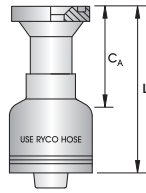

HOSE SIZE	NOM. FLANGE SIZE	DASH SIZE	CODE 61 FLANGE						CODE 61 FLANGE 45° TUBE BEND						
			PART NO		CA		L		PART NO		CA		L		DL
DN	inch	inch		inch	mm	inch	mm	inch	mm	inch	mm	inch	mm	inch	mm
19	3/4	3/4	-1212	<b>p2481212</b>	1.81	46	3.03	77	<b>T4150-1212</b>	2.56	65	3.78	96	1.02	26
19	3/4	1	-1216	<b>T4130-1216</b>	1.97	50	3.19	81							
25	1	1	-1616	<b>T4130-1616</b>	2.05	52	3.35	85	<b>T4150-1616</b>	3.19	81	4.53	115	1.18	30
25	1	1.1/4	-1620	<b>T4130-1620</b>	2.24	57	3.54	90							
31	1.1/4	1.1/4	-2020	<b>T4130-2020</b>	2.32	59	4.25	108	<b>T4150-2020</b>	3.94	100	5.87	149	1.42	36
31	1.1/4	1.1/2	-2024	<b>T4130-2024</b>	3.35	85	5.28	134							
38	1.1/2	1.1/4	-2420						<b>T4150-2420</b>	4.06	103	5.98	152	1.50	38
38	1.1/2	1.1/2	-2424	<b>T4130-2424</b>	3.35	85	5.31	135	<b>T4150-2424</b>	4.33	110	6.26	159	1.65	42
38	1.1/2	2	-2432	<b>T4130-2432</b>	3.74	95	5.71	145	<b>T4150-2432</b>	4.72	120	6.65	169	1.85	47
51	2	2	-3232	<b>T4130-3232</b>	3.78	96	5.87	149	<b>T4150-3232</b>	5.91	150	7.99	203	2.28	58
63	2.1/2	2.1/2	-4040	<b>T4130-4040</b>	3.11	79	5.75	146							

SAE FLANGE	T4170	T4173
------------	-------	-------

RYCO  
CODE 61  
CLAMPS - SEE PAGES  
440 & 441  
O RING NOT SUPPLIED

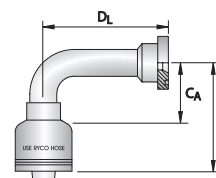
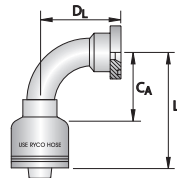

HOSE SIZE	NOM. FLANGE SIZE	DASH SIZE	CODE 61 FLANGE 90° TUBE BEND						CODE 61 FLANGE 90° LONG BEND								
			PART NO		CA		L		DL		PART NO		CA		L		DL
DN	inch	inch		inch	mm	inch	mm	inch	mm		inch	mm	inch	mm	inch	mm	
19	3/4	3/4	-1212	<b>T4170-1212</b>	2.17	55	3.39	86	2.13	54							
25	1	1	-1616	<b>T4170-1616</b>	2.83	72	4.17	106	2.68	68							
25	1	1.1/4	-1620								<b>T4173-1620</b>	2.83	72	4.17	106	3.66	93
31	1.1/4	1.1/4	-2020	<b>T4170-2020</b>	3.94	100	5.87	149	3.07	78							
38	1.1/2	1.1/2	-2424	<b>T4170-2424</b>	4.09	104	6.02	153	3.66	93							
38	1.1/2	2	-2432	<b>T4170-2432</b>	3.82	97	5.75	146	3.90	99							
51	2	2	-3232	<b>T4170-3232</b>	5.39	137	7.48	190	5.12	130							
51	2	2.1/2	-3240	<b>T4170-3240</b>	5.55	141	7.64	194	5.28	134							

**NOTE:** Hose Compatibility for the **T4000** series can be found on page 233.

## T4000 SERIES ONE-PIECE CRIMP COUPLINGS

### UN O RING MALE T4200

O RING SUPPLIED

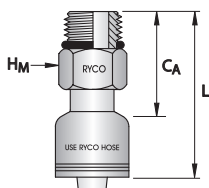

HOSE SIZE		TUBE SIZE	DASH SIZE	MALE HEX		UN O RING MALE				
DN	inch	inch		HM-SPANNER		PART NO	CA		L	
				inch	mm		inch	mm	inch	mm
6	1/4	7/16	-0407	9/16		<b>T4200-0407</b>	1.06	27	2.05	52
25	1	1.5/16	-1621	1.1/2	38	<b>T4200-1621</b>	1.73	44	3.03	77

### SALVAGE T4230

TUBE WELD

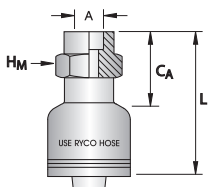

HOSE SIZE		A	DASH SIZE	MALE HEX		SALVAGE (LIFESAVER)				
DN	inch	inch		HM-SPANNER		PART NO	CA		L	
				inch	mm		inch	mm	inch	mm
8	5/16	3/8	-0506	5/8	16	<b>T4230-0506</b>	0.98	25	1.97	50
10	3/8	3/8	-0606	5/8	16	<b>T4230-0606</b>	1.02	26	2.01	51
12	1/2	1/2	-0808	3/4	19	<b>T4230-0808</b>	1.06	27	2.05	52
16	5/8	3/4	-1012	1.1/16	27	<b>T4230-1012</b>	1.02	26	2.28	58
19	3/4	3/4	-1212	1.1/16	27	<b>T4230-1212</b>	1.18	30	2.40	61
25	1	1	-1616	1.3/8		<b>T4230-1616</b>	1.38	35	2.68	68
31	1.1/4	1.1/4	-2020	1.5/8	41	<b>T4230-2020</b>	1.57	40	3.54	90
38	1.1/2	1.1/2	-2424	2	50	<b>T4230-2424</b>	1.34	34	3.31	84
51	2	2	-3232	2,1/2		<b>T4230-3232</b>	1.61	41	3.70	94

### TUBE BITE T4850

COMPLETE WITH NUT AND FLARELESS OLIVE

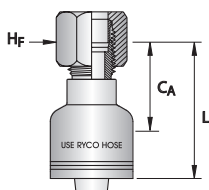

HOSE SIZE		TUBE SIZE	DASH SIZE	FEMALE HEX		TUBE BITE				
DN	inch	inch		HF-SPANNER		PART NO	CA		L	
				inch	mm		inch	mm	inch	mm
10	3/8	9/16	-0606	11/16		<b>T4850-0606</b>	1.30	33	2.28	58

**NOTE:** Hose Compatibility for the **T4000** series can be found on page 233.

INTRODUCTION

HOSE

COUPLINGS

ADAPTORS

TECHNICAL

# COUPLINGS

## T6000 SERIES ONE-PIECE CRIMP COUPLINGS

### HOSE COMPATIBILITY FOR T6000 SERIES

#### NON-SKIVE

For RYCO Hose Series H5000 (sizes -24 to -32).  
For RYCO Hose Series H6000 (sizes -12 to -32).

#### NON-SKIVE

### BSPT - MALE

### T6010

60° SEAT

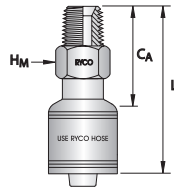

HOSE SIZE		THRD SIZE	DASH SIZE	MALE HEX		BSPT MALE				
DN	inch	inch		HM-SPANNER		PART NO	CA		L	
				inch	mm		inch	mm	inch	mm
19	3/4	3/4	-1212	1.1/16	27	<b>T6010-1212</b>	1.89	48	3.94	100
25	1	1	-1616		36	<b>T6010-1616</b>	2.09	53	4.65	118
31	1.1/4	1.1/4	-2020		46	<b>T6010-2020</b>	2.32	59	5.00	127
38	1.1/2	1.1/2	-2424	2	50	<b>T6010-2424</b>	2.20	56	5.67	144
51	2	2	-3232		65	<b>T6010-3232</b>	2.80	71	6.97	177

### BSPP - MALE

### T6013

60° SEAT

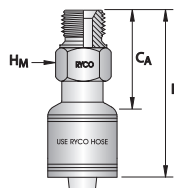

HOSE SIZE		THRD SIZE	DASH SIZE	MALE HEX		BSPP MALE				
DN	inch	inch		HM-SPANNER		PART NO	CA		L	
				inch	mm		inch	mm	inch	mm
19	3/4	3/4	-1212	1.1/4	32	<b>T6013-1212</b>	1.85	47	3.90	99
25	1	1	-1616	1.5/8	41	<b>T6013-1616</b>	2.01	51	4.61	117
31	1.1/4	1.1/4	-2020	2	50	<b>T6013-2020</b>	2.36	60	5.04	128
38	1.1/2	1.1/2	-2424	2.3/16	55	<b>T6013-2424</b>	2.20	56	5.63	143
51	2	2	-3232	2.3/4	70	<b>T6013-3232</b>	2.83	72	7.01	178

**NOTE:** Hose Compatibility for the **T6000** series can be found on page 250

## T6000 SERIES ONE-PIECE CRIMP COUPLINGS

INTRODUCTION

HOSE

COUPLINGS

ADAPTORS

TECHNICAL

<b>BSPP</b>	<b>T6020</b>	<b>T6022</b>
-------------	--------------	--------------

60° SEAT

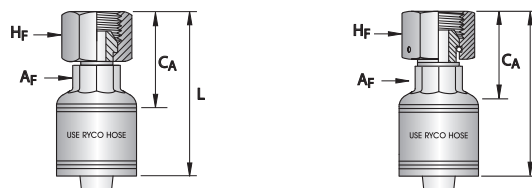

HOSE SIZE		THRD SIZE	DASH SIZE	BACK UP Af		FEMALE HEX		BSPP FEMALE				BSPP FEMALE HEAVY					
DN	inch	inch		inch	mm	inch	mm	PART NO		CA	L		PART NO		CA	L	
								inch	mm	inch	mm	inch	mm	inch	mm	inch	mm
19	3/4	3/4	-1212	1.1/16	27	1.1/4	32	<b>T6020-1212</b>	1.22	31	3.27	83	<b>T6022-1212</b>	1.22	31	3.27	83
25	1	1	-1616	1.1/4	32	1.1/2	38	<b>T6020-1616</b>	1.50	38	4.09	104	<b>T6022-1616</b>	1.50	38	4.09	104
31	1.1/4	1	-2016	1.11/16		1.1/2	38	<b>T6020-2016</b>	1.69	43	4.37	111					
31	1.1/4	1.1/4	-2020	1.11/16		2	50	<b>T6020-2020</b>	1.73	44	4.41	112	<b>T6022-2020</b>	1.73	44	4.41	112
38	1.1/2	1.1/2	-2424	2.3/16	55	2.3/16	55	<b>T6020-2424</b>	1.89	48	5.31	135					
51	2	2	-3232	2.5/8		2.3/4	70	<b>T6020-3232</b>	2.36	60	6.50	165					

<b>BSPP</b>	<b>T6270</b>	<b>T6260</b>
-------------	--------------	--------------

60° SEAT



HOSE SIZE		THRD SIZE	DASH SIZE	FEMALE HEX		BSPP FEMALE 45° BEND					BSPP FEMALE 90° BEND										
DN	inch	inch		Hf-SPANNER		PART NO		CA		L		DL		PART NO		CA		L		DL	
				inch	mm	inch	mm	inch	mm	inch	mm	inch	mm	inch	mm	inch	mm	inch	mm	inch	mm
19	3/4	3/4	-1212	1.1/4	32	<b>T6270-1212</b>	2.83	72	4.88	124	1.14	29	<b>T6260-1212</b>	2.32	59	4.37	111	2.28	58		
25	1	1	-1616	1.1/2	38	<b>T6270-1616</b>	3.62	92	6.22	158	1.54	39	<b>T6260-1616</b>	2.87	73	5.47	139	3.15	80		
31	1.1/4	1.1/4	-2020	2	50	<b>T6270-2020</b>	4.29	109	6.97	177	1.81	46	<b>T6260-2020</b>	3.94	100	6.61	168	3.58	91		
38	1.1/2	1.1/2	-2424	2.3/16	55	<b>T6270-2424</b>	4.69	119	8.15	207	2.05	52	<b>T6260-2424</b>	4.09	104	7.56	192	4.13	105		
51	2	2	-3232	2.3/4	70	<b>T6270-3232</b>	5.83	148	9.96	253	2.56	65	<b>T6260-3232</b>	5.31	135	9.45	240	5.20	132		

**NOTE:** Hose Compatibility for the **T6000** series can be found on page 250

# COUPLINGS

## T6000 SERIES ONE-PIECE CRIMP COUPLINGS

<b>NPT</b>	<b>T6090</b>	<b>T6091</b>
------------	--------------	--------------

60° SEAT

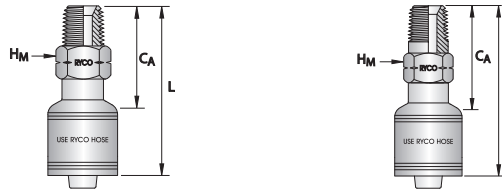

HOSE SIZE		THRD SIZE	DASH SIZE	MALE HEX	NPT MALE				NPT MALE EXTENDED							
DN	inch	inch		H <sub>M</sub> -SPANNER inch mm	PART NO		C <sub>A</sub> inch mm		L inch mm		PART NO		C <sub>A</sub> inch mm		L inch mm	
19	3/4	3/4	-1212	1.1/16	27	<b>T6090-1212</b>	1.85	47	3.90	99						
25	1	1	-1616	1.3/8		<b>T6090-1616</b>	2.09	53	4.65	118						
31	1.1/4	1.1/4	-2020	1.3/4		<b>T6090-2020</b>	2.32	59	5.00	127						
38	1.1/2	1.1/2	-2424	2	50	<b>T6090-2424</b>	2.20	56	5.67	144						
51	2	2	-3232	2.1/2		<b>T6090-3232</b>	2.80	71	6.97	177	<b>T6091-3232</b>	4.45	113	8.58	218	

<b>NPT</b>	<b>T6020N</b>
------------	---------------

60° SEAT

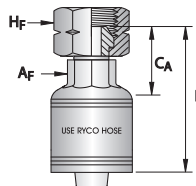

HOSE SIZE		THRD SIZE	DASH SIZE	BACK UP A <sub>F</sub>	FEMALE HEX	NPSM FEMALE						
DN	inch	inch		A <sub>F</sub> -SPANNER inch mm	H <sub>F</sub> -SPANNER inch mm	PART NO		C <sub>A</sub> inch mm		L inch mm		
19	3/4	3/4	-1212	1.1/16	27	1.1/4	32	<b>T6020N-1212</b>	1.22	31	3.27	83
25	1	1	-1616	1.1/4	32	1.1/2	38	<b>T6020N-1616</b>	1.50	38	4.09	104
31	1.1/4	1.1/4	-2020	1.1.16		2	50	<b>T6020N-2020</b>	1.73	44	4.41	112
38	1.1/2	1.1/2	-2424	2.3/16	55	2.1/4	58	<b>T6020N-2424</b>	1.89	48	5.31	135
51	2	2	-3232	2.5/8		2.3/4	70	<b>T6020N-3232</b>	2.36	60	6.50	165

<b>JIC - MALE</b>	<b>T6030 - T6031</b>
-------------------	----------------------

37° FLARE

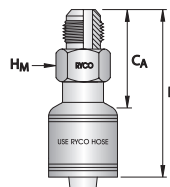

HOSE SIZE		THRD SIZE	TUBE SIZE	DASH SIZE	MALE HEX	JIC MALE					
DN	inch	inch	inch		H <sub>M</sub> -SPANNER inch mm	PART NO		C <sub>A</sub> inch mm		L inch mm	
19	3/4	1.1/16	3/4	-1217	1.1/16	27	<b>T6030-1217</b>	1.97	50	4.02	102
25	1	1.5/16	1	-1621	1.3/8		<b>T6030-1621</b>	2.05	52	4.61	117
						36	<b>T6031-1621</b>				
31	1.1/4	1.5/8	1.1/4	-2026	1.3/4		<b>T6030-2026</b>	2.32	59	5.00	127
38	1.1/2	1.7/8	1.1/2	-2430	2	50	<b>T6030-2430</b>	2.28	58	5.75	146
51	2	2.1/2	2	-3240	2.1/2		<b>T6030-3240</b>	3.11	79	7.24	184

**NOTE:** Hose Compatibility for the **T6000** series can be found on page 250

## T6000 SERIES ONE-PIECE CRIMP COUPLINGS

INTRODUCTION

HOSE

COUPLINGS

ADAPTORS

TECHNICAL

<b>JSEAL™ / JIC</b>	<b>T6040</b>
---------------------	--------------

**CONVEX SEAT**

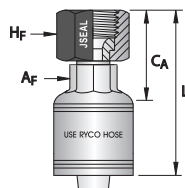

HOSE SIZE		THRD SIZE	TUBE SIZE	DASH SIZE	BACK UP Af		FEMALE HEX		JSEAL™ JIC FEMALE				
DN	inch	inch	inch		Af-SPANNER		Hf-SPANNER		PART NO	Ca		L	
	inch	inch	inch		inch	mm	inch	mm		inch	mm	inch	mm
19	3/4	1.1/16	3/4	-1217	1.1/16	27	1.1/4	32	<b>T6040-1217</b>	1.22	31	3.27	83
19	3/4	1.5/16	1	-1221	1.1/16	27	1.1/2	38	<b>T6040-1221</b>	1.34	34	3.39	86
25	1	1.5/16	1	-1621	1.1/4	32	1.1/2	38	<b>T6040-1621</b>	1.38	35	3.98	101
25	1	1.5/8	1.1/4	-1626	1.1/4	32	2	50	<b>T6040-1626</b>	1.65	42	4.21	107
31	1.1/4	1.5/8	1.1/4	-2026	1.11/16		2	50	<b>T6040-2026</b>	1.65	42	4.33	110
31	1.1/4	1.7/8	1.1/2	-2030	1.11/16		2.1/4	57	<b>T6040-2030</b>	2.01	51	4.69	119
38	1.1/2	1.7/8	1.1/2	-2430	2.3/16	55	2.1/4	57	<b>T6040-2430</b>	2.13	54	5.59	142
51	2	2.1/2	2	-3240	2.5/8		2.7/8	73	<b>T6040-3240</b>	2.64	67	6.77	172

<b>JIC - HEAVY DUTY</b>	<b>T6045</b>
-------------------------	--------------

**37° FLARE**

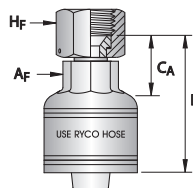

HOSE SIZE		THRD SIZE	TUBE SIZE	DASH SIZE	BACK UP Af		FEMALE HEX		JIC FEMALE HIGH PRESSURE				
DN	inch	inch	inch		Af-SPANNER		Hf-SPANNER		PART NO	Ca		L	
	inch	inch	inch		inch	mm	inch	mm		inch	mm	inch	mm
25	1	1.5/16	1	-1621	1.3/8		1.5/8	41	<b>T6045-1621</b>	1.38	35	3.98	101

<b>JSEAL™ / JIC</b>	<b>T6250</b>
---------------------	--------------

**CONVEX SEAT**

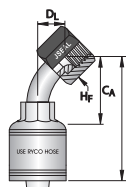

HOSE SIZE		THRD SIZE	TUBE SIZE	DASH SIZE	FEMALE HEX		JSEAL™ / JIC FEMALE 45° BEND						
DN	inch	inch	inch		Hf-SPANNER		PART NO	Ca		L		Df	
	inch	inch	inch		inch	mm		inch	mm	inch	mm	inch	mm
19	3/4	1.1/16	3/4	-1217	1.1/4	32	<b>T6250-1217</b>	2.76	70	4.80	122	1.10	28
25	1	1.5/16	1	-1621	1.1/2	38	<b>T6250-1621</b>	3.31	84	5.91	150	1.38	35
31	1.1/4	1.5/8	1.1/4	-2026	2	50	<b>T6250-2026</b>	4.02	102	6.69	170	1.54	39
38	1.1/2	1.7/8	1.1/2	-2430	2.1/4	57	<b>T6250-2430</b>	5.04	128	8.50	216	1.97	50
51	2	2.1/2	2	-3240	2.7/8	73	<b>T6250-3240</b>	6.46	164	10.59	269	2.48	63

**NOTE:** Hose Compatibility for the **T6000** series can be found on page 250



# COUPLINGS

## T6000 SERIES ONE-PIECE CRIMP COUPLINGS

JSEAL™ / JIC

T6280

CONVEX SEAT

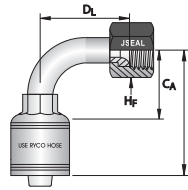

HOSE SIZE	THRD SIZE	TUBE SIZE	DASH SIZE	FEMALE HEX	JSEAL™ / JIC FEMALE 90° BEND								
DN	inch	inch			HF-SPANNER		PART NO	CA		L		DL	
					inch	mm		inch	mm	inch	mm	inch	mm
19	3/4	1.1/16	3/4	-1217	1.1/4	32	<b>T6280-1217</b>	2.32	59	4.37	111	3.78	96
25	1	1.5/16	1	-1621	1.1/2	38	<b>T6280-1621</b>	2.95	75	5.55	141	4.49	114
31	1.1/4	1.5/8	1.1/4	-2026	2	50	<b>T6280-2026</b>	3.94	100	6.61	168	5.08	129

JSEAL™ / JIC

T6240

CONVEX SEAT

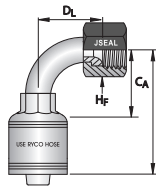

HOSE SIZE	THRD SIZE	TUBE SIZE	DASH SIZE	FEMALE HEX	JSEAL™ / JIC FEMALE 90° MEDIUM BEND								
DN	inch	inch	inch		HF-SPANNER		PART NO	CA		L		DL	
					inch	mm		inch	mm	inch	mm	inch	mm
19	3/4	1.1/16	3/4	-1217	1.1/4	32	<b>T6240-1217</b>	2.32	59	4.37	111	2.24	57
19	3/4	1.5/16	1	-1221	1.1/2	38	<b>T6240-1221</b>	2.32	59	4.37	111	2.80	71
25	1	1.5/16	1	-1621	1.1/2	38	<b>T6240-1621</b>	2.87	73	5.47	139	2.83	72
31	1.1/4	1.5/8	1.1/4	-2026	2	50	<b>T6240-2026</b>	3.94	100	6.61	168	3.19	81
38	1.1/2	1.7/8	1.1/2	-2430	2.1/4	57	<b>T6240-2430</b>	4.17	106	7.64	194	4.17	106
51	2	2.1/2	2	-3240	2.7/8	73	<b>T6240-3240</b>	5.83	148	9.96	253	5.20	132

JOINER

T6900

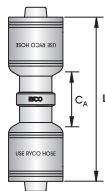

HOSE SIZE	DASH SIZE	BSPP FEMALE					
DN	inch		PART NO	CA		L	
				inch	mm	inch	mm
19	3/4	-1212	<b>T6900-1212</b>	0.98	25	3.03	77
25	1	-1616	<b>T6900-1616</b>	1.26	32	3.82	97
31	1.1/4	-2020	<b>T6900-2020</b>	1.57	40	4.25	108
38	1.1/2	-2424	<b>T6900-2424</b>	1.06	27	4.53	115
51	2	-3232	<b>T6900-3232</b>	1.42	36	5.59	142

**NOTE:** Hose Compatibility for the T6000 series can be found on page 250

## T6000 SERIES ONE-PIECE CRIMP COUPLINGS

### METRIC - DKS T6630

**DKS**  
METRIC (HEAVY)  
24° CONE

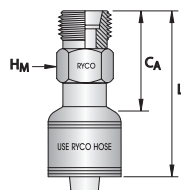

HOSE SIZE	THRD SIZE	TUBE SIZE	DASH SIZE	MALE HEX	DKS MALE 24° CONE						
DN	inch	inch	inch	inch	HM-SPANNER		PART NO	CA		L	
					inch	mm		inch	mm	inch	mm
19	3/4	30	20	-1230	1.1/4	32	<b>T6630-1230</b>	1.73	44	3.78	96
19	3/4	36	25	-1236	1.5/8	41	<b>T6630-1236</b>	1.89	48	3.94	100
25	1	36	25	-1636	1.5/8	41	<b>T6630-1636</b>	1.89	48	4.49	114
25	1	42	30	-1642		46	<b>T6630-1642</b>	2.01	51	4.61	117
31	1.1/4	52	38	-2052	2.3/16	55	<b>T6630-2052</b>	2.32	59	5.00	127
38	1.1/2	52	38	-2452	2.3/16	55	<b>T6630-2452</b>	2.17	55	5.63	143

### METRIC - DKOS T6711 T6720

**DKOS**  
METRIC O RING (HEAVY)  
24° CONE

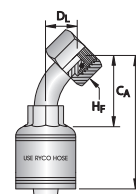
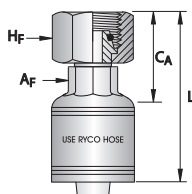

HOSE SIZE	THRD SIZE	TUBE SIZE	DASH SIZE	BACK UP AF	FEMALE HEX	DKOS FEMALE 24° CONE						DKOS FEMALE 24° CONE/45° BEND								
DN	inch	inch	inch	inch	inch	AF-SPANNER		HF-SPANNER	PART NO	CA		L		PART NO	CA		L		DL	
						inch	mm			inch	mm	inch	mm		inch	mm	inch	mm	inch	mm
19	3/4	30	20	-1230	1.1/16	27		36	<b>T6711-1230</b>	1.50	38	3.54	90	<b>T6720-1230</b>	2.99	76	5.04	128	1.38	35
19	3/4	36	25	-1236	1.1/16	27		46	<b>T6711-1236</b>	1.61	41	3.66	93	<b>T6720-1236</b>	2.99	76	5.04	128	1.38	35
25	1	36	25	-1636	1.1/4	32		46	<b>T6711-1636</b>	1.81	46	4.37	111							
25	1	42	30	-1642	1.1/4	32	2	50	<b>T6711-1642</b>	1.85	47	4.41	112	<b>T6720-1642</b>	3.50	89	6.10	155	1.46	37
31	1.1/4	52	38	-2052	1.11/16		2.3/8	60	<b>T6711-2052</b>	2.24	57	4.92	125	<b>T6720-2052</b>	5.04	128	7.72	196	1.89	48
38	1.1/2	52	38	-2452	2.3/16	55	2.3/8	60	<b>T6711-2452</b>	2.32	59	5.79	147	<b>T6720-2452</b>	5.08	129	8.54	217	1.89	48

### METRIC - DKOS T6730

**DKOS**  
METRIC O RING (HEAVY)  
24° CONE

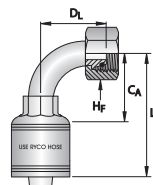

HOSE SIZE	THRD SIZE	TUBE SIZE	DASH SIZE	FEMALE HEX	DKOS FEMALE 24° CONE/90° BEND								
DN	inch	inch	inch	inch	HF-SPANNER		PART NO	CA		L		DL	
					inch	mm		inch	mm	inch	mm	inch	mm
19	3/4	30	20	-1230		36	<b>T6730-1230</b>	2.32	59	4.37	111	2.68	68
19	3/4	36	25	-1236		46	<b>T6730-1236</b>	2.32	59	4.37	111	2.68	68
25	1	42	30	-1642	2	50	<b>T6730-1642</b>	2.87	73	5.47	139	3.03	77
31	1.1/4	52	38	-2052	2.3/8	60	<b>T6730-2052</b>	3.94	100	6.61	168	3.50	89
38	1.1/2	52	38	-2452	2.3/8	60	<b>T6730-2452</b>	3.58	91	7.05	179	3.50	89

INTRODUCTION

HOSE

COUPLINGS

ADAPTORS

TECHNICAL

# COUPLINGS

## T6000 SERIES ONE-PIECE CRIMP COUPLINGS

ORFS	T6840
------	-------

O RING  
FACE SEAL

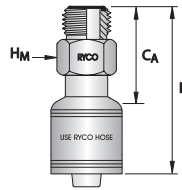

HOSE SIZE		THRD SIZE	TUBE SIZE	DASH SIZE	MALE HEX		PART NO	C <sub>A</sub>		L	
DN	inch	inch	inch		inch	mm		inch	mm	inch	mm
19	3/4	1.3/16	3/4	-1219	1.1/4	32	<b>T6840-1219</b>	1.85	47	3.90	99
25	1	1.7/16	1	-1623	1.1/2	38	<b>T6840-1623</b>	2.05	52	4.61	117
31	1.1/4	1.11/16	1.1/4	-2027	2	50	<b>T6840-2027</b>	2.24	57	4.92	125
38	1.1/2	2	1.1/2	-2432	2.3/16	55	<b>T6840-2432</b>	2.01	51	5.47	139

ORFS	T6800 - T6801	T6810 - T6811
------	---------------	---------------

O RING  
FACE SEAL

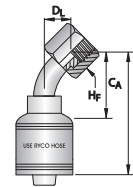
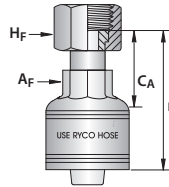

HOSE SIZE		THRD SIZE	TUBE SIZE	DASH SIZE	BACK UP A <sub>F</sub>		FEMALE HEX		ORFS FEMALE				ORFS FEMALE 45° BEND							
DN	inch	inch	inch		A <sub>F</sub> -SPANNER		H <sub>F</sub> -SPANNER		PART NO	C <sub>A</sub>		L		PART NO	C <sub>A</sub>		L		D <sub>L</sub>	
					inch	mm	inch	mm		inch	mm	inch	mm		inch	mm	inch	mm	inch	mm
19	3/4	1.3/16	3/4	-1219	1.1/16	27	1.3/8	36	<b>T6800-1219</b>	1.73	44	3.78	96	<b>T6810-1219</b>	2.76	70	4.80	122	1.14	29
									<b>T6801-1219</b>					<b>T6811-1219</b>						
19	3/4	1.7/16	1	-1223	1.1/16	27	1.5/8	41	<b>T6800-1223</b>	1.69	43	3.74	95							
25	1	1.7/16	1	-1623	1.1/4	32	1.5/8	41	<b>T6800-1623</b>	1.65	42	4.21	107	<b>T6810-1623</b>	3.43	87	6.02	153	1.34	34
25	1	1.11/16	1.1/4	-1627	1.1/4	32	2	50	<b>T6800-1627</b>	1.73	44	4.29	109							
31	1.1/4	1.11/16	1.1/4	-2027	1.11/16	2	50	50	<b>T6800-2027</b>	1.85	47	4.53	115	<b>T6810-2027</b>	4.29	109	6.97	177	1.77	45
38	1.1/2	2	1.1/2	-2432	2.3/16	55	2.1/4	57	<b>T6800-2432</b>	2.52	64	5.98	152	<b>T6810-2432</b>	5.00	127	8.46	215	2.09	53

**NOTE:** Hose Compatibility for the **T6000** series can be found on page 250

## T6000 SERIES ONE-PIECE CRIMP COUPLINGS

### ORFS T6820 - T6821

O RING  
FACE SEAL

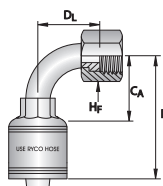

HOSE SIZE					FEMALE HEX		ORFS FEMALE 90° BEND					
DN	inch	inch	inch	DASH SIZE	HF-SPANNER	PART NO	CA		L		DL	
					inch	mm	inch	mm	inch	mm	inch	mm
19	3/4	1.3/16	3/4	-1219	1.3/8	<b>T6820-1219</b>	2.32	59	4.37	111	2.32	59
					36	<b>T6821-1219</b>						
19	3/4	1.7/16	1	-1223	1.5/8	<b>T6820-1223</b>	2.32	59	4.37	111	2.09	53
25	1	1.7/16	1	-1623	1.5/8	<b>T6820-1623</b>	2.87	73	5.47	139	2.80	71
31	1.1/4	1.11/16	1.1/4	-2027	2	<b>T6820-2027</b>	3.94	100	6.61	168	3.54	90
38	1.1/2	2	1.1/2	-2432	2.1/4	<b>T6820-2432</b>	4.17	106	7.64	194	4.21	107

### RYCOLOK T6871 T6872

STAPLE  
O RING & BACK UP RING  
SUPPLIED

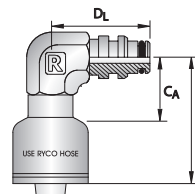
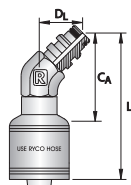

HOSE SIZE				RYCOLOK MALE 45° ELBOW						RYCOLOK MALE 90° ELBOW									
DN	inch	DN	DASH SIZE	PART NO		CA		L		DL		PART NO		CA		L		DL	
						inch	mm	inch	mm	inch	mm			inch	mm	inch	mm	inch	mm
19	3/4	20	-1220									<b>T6872-1220</b>	2.09	53	4.13	105	2.20	56	
25	1	25	-1625									<b>T6872-1625</b>	2.05	52	4.65	118	2.68	68	
51	2	50	-3250	<b>T6871-3250</b>	3.43	87	7.56	192	1.81	46									

### RYCOLOK T6870

STAPLE  
O RING & BACK UP RING  
SUPPLIED

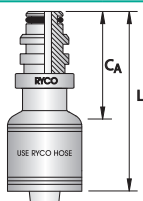

### SUPERLOK T6876

SUPERSTAPLE  
O RING & BACK UP RING  
SUPPLIED

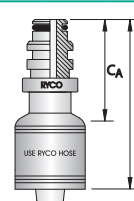

HOSE SIZE				RYCOLOK MALE					
DN	inch	DN	DASH SIZE	PART NO		CA		L	
						inch	mm	inch	mm
19	3/4	20	-1220	<b>T6870-1220</b>	1.89	48	3.94	100	
25	1	25	-1625	<b>T6870-1625</b>	2.28	58	4.84	123	
31	1.1/4	32	-2032	<b>T6870-2032</b>	2.32	59	5.00	127	
38	1.1/2	40	-2440	<b>T6870-2440</b>	2.40	61	5.83	148	
51	2	50	-3250	<b>T6870-3250</b>	2.48	63	6.61	168	

HOSE SIZE				SUPERLOK MALE					
DN	inch	DN	DASH SIZE	PART NO		CA		L	
						inch	mm	inch	mm
19	3/4	20	-1220	<b>T6876-1220</b>	2.24	57	4.29	109	
25	1	25	-1625	<b>T6876-1625</b>	2.95	75	5.55	141	
31	1.1/4	32	-2032	<b>T6876-2032</b>	3.15	80	5.83	148	
38	1.1/2	40	-2440	<b>T6876-2440</b>	3.11	79	6.57	167	
51	2	50	-3250	<b>T6876-3250</b>	3.31	84	7.44	189	

**NOTE:** Hose Compatibility for the **T6000** series can be found on page 250

INTRODUCTION

HOSE

COUPLINGS

ADAPTORS

TECHNICAL

# COUPLINGS

## T6000 SERIES ONE-PIECE CRIMP COUPLINGS

### DIMENSIONS FOR SAE CODE 61 AND CODE 62 FLANGES, AND RYCO CODE 62C FLANGES

NOMINAL FLANGE	CODE 61				CODE 62				CODE 62C			
	B		T		B		T		B		T	
inch	mm	inch	mm	inch	mm	inch	mm	inch	mm	inch	mm	inch
1/2	30,2	1.19	6,73	0.265	31,8	1.25	7,75	0.305				
5/8	34,0	1.34	6,73	0.265								
3/4	38,1	1.50	6,73	0.265	41,3	1.63	8,76	0.345	41,3	1.63	14,20	0.559
1	44,5	1.75	8,00	0.315	47,6	1.88	9,53	0.375	47,6	1.88	14,20	0.559
1.1/4	50,8	2.00	8,00	0.315	54,0	2.12	10,29	0.405	54,0	2.12	14,20	0.559
1.1/2	60,3	2.38	8,00	0.315	63,5	2.50	12,57	0.495	63,5	2.50	14,20	0.559
2	71,4	2.81	9,53	0.375	79,4	3.13	12,57	0.495	79,4	3.13	14,20	0.559
2.1/2	84,1	3.31	9,53	0.375								
3	101,6	4.00	9,53	0.375								

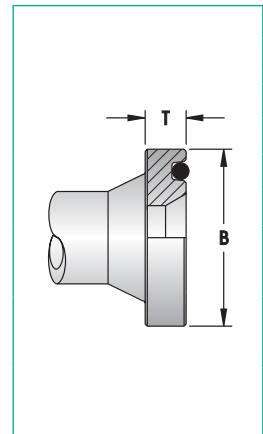

**NOTE:** RYCO Code 62C fittings conform to the flange OD and bolt hole patterns of SAE Code 62 but require special flange clamps. RYCO Code 62C flange heads are thicker than SAE Code 62 and measure T = 14,2 mm (0.559 inch) in all sizes.

SAE FLANGE	T6130	T6140
------------	-------	-------

**RYCO  
CODE 61  
CLAMPS - SEE PAGES  
440 & 441  
O RING NOT SUPPLIED**

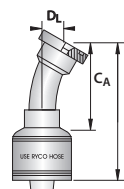
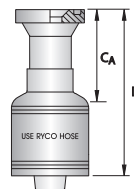

HOSE SIZE	NOM. FLANGE SIZE	DASH SIZE	CODE 61 FLANGE						CODE 61 FLANGE 22.5° TUBE BEND					
			PART NO		CA		L		PART NO		CA		L	
DN	inch	inch		inch	mm	inch	mm		inch	mm	inch	mm	inch	mm
19	3/4	3/4	-1212	<b>T6130-1212</b>	1.89	48	3.94	100						
19	3/4	1	-1216	<b>T6130-1216</b>	2.05	52	4.09	104						
25	1	1	-1616	<b>T6130-1616</b>	2.09	53	4.69	119						
25	1	1.1/4	-1620	<b>T6130-1620</b>	2.28	58	4.88	124						
31	1.1/4	1.1/4	-2020	<b>T6130-2020</b>	2.40	61	5.08	129						
38	1.1/2	1.1/2	-2424	<b>T6130-2424</b>	3.43	87	6.85	174						
51	2	2	-3232	<b>T6130-3232</b>	3.98	101	8.11	206						

**NOTE:** Hose Compatibility for the **T6000** series can be found on page 250

## T6000 SERIES ONE-PIECE CRIMP COUPLINGS

### SAE FLANGE T6290

RYCO  
CODE 61  
CLAMPS - SEE PAGES  
440 & 441  
O RING NOT SUPPLIED

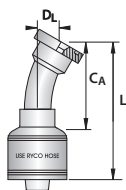

HOSE SIZE		NOM. FLANGE SIZE	DASH SIZE	CODE 61 FLANGE 30° TUBE BEND						
DN	inch	inch		PART NO	CA		L		DL	
					inch	mm	inch	mm	inch	mm
19	3/4	3/4	-1212	<b>T6290-1212</b>	2.83	72	4.88	124	0.71	18
25	1	1	-1616	<b>T6290-1616</b>	3.70	94	6.30	160	0.87	22
31	1.1/4	1.1/4	-2020	<b>T6290-2020</b>	4.17	106	6.85	174	0.79	20
31	1.1/4	1.1/2	-2024	<b>T6290-2024</b>	4.37	111	7.05	179	0.94	24
38	1.1/2	1.1/2	-2424	<b>T6290-2424</b>	4.65	118	8.11	206	1.02	26
38	1.1/2	2	-2432	<b>T6290-2432</b>	5.12	130	8.58	218	1.26	32
51	2	2	-3232	<b>T6290-3232</b>	6.06	154	10.20	259	1.18	30

### SAE FLANGE T6150 T6300

RYCO  
CODE 61  
CLAMPS - SEE PAGES  
O RING NOT SUPPLIED

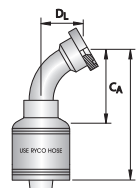
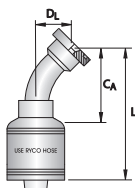

HOSE SIZE		NOM. FLANGE SIZE	DASH SIZE	CODE 61 FLANGE 45° BEND							CODE 61 FLANGE 60° TUBE BEND						
DN	inch	inch		PART NO	CA		L		DL		PART NO	CA		L		DL	
					inch	mm	inch	mm	inch	mm		inch	mm	inch	mm	inch	mm
19	3/4	3/4	-1212	<b>T6150-1212</b>	2.68	68	4.72	120	1.02	26	<b>T6300-1212</b>	3.15	80	5.20	132	1.46	37
19	3/4	1	-1216	<b>T6150-1216</b>	2.76	70	4.80	122	1.18	30	<b>T6300-1216</b>	3.23	82	5.28	134	1.61	41
25	1	1	-1616	<b>T6150-1616</b>	3.27	83	5.87	149	1.18	30	<b>T6300-1616</b>	3.90	99	6.50	165	1.81	46
25	1	1.1/4	-1620	<b>T6150-1620</b>	3.35	85	5.94	151	1.26	32	<b>T6300-1620</b>	3.82	97	6.42	163	1.77	45
31	1.1/4	1.1/4	-2020	<b>T6150-2020</b>	4.02	102	6.69	170	1.50	38	<b>T6300-2020</b>	4.69	119	7.36	187	2.01	51
31	1.1/4	1.1/2	-2024								<b>T6300-2024</b>	4.76	121	7.44	189	2.13	54
38	1.1/2	1.1/2	-2424	<b>T6150-2424</b>	4.57	116	8.03	204	1.65	42	<b>T6300-2424</b>	5.67	144	9.13	232	2.36	60
38	1.1/2	2	-2432								<b>T6300-2432</b>	5.79	147	9.25	235	2.68	68
51	2	2	-3232	<b>T6150-3232</b>	5.91	150	10.04	255	2.28	58	<b>T6300-3232</b>	7.32	186	11.46	291	3.23	82

**NOTE:** Hose Compatibility for the **T6000** series can be found on page 250

INTRODUCTION

HOSE

COUPLINGS

ADAPTORS

TECHNICAL



# COUPLINGS

## T6000 SERIES ONE-PIECE CRIMP COUPLINGS

<b>SAE FLANGE</b>	<b>T6170</b>
-------------------	--------------

RYCO  
CODE 61  
CLAMPS - SEE PAGES  
440 & 441  
O RING NOT SUPPLIED

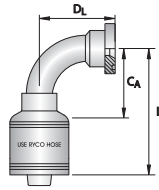

HOSE SIZE		NOM. FLANGE SIZE	DASH SIZE	CODE 61 FLANGE 90° TUBE BEND							
DN	inch	inch		PART NO	CA		L		DL		
					inch	mm	inch	mm	inch	mm	
19	3/4	3/4	-1212	<b>T6170-1212</b>	2.32	59	4.37	111	2.13	54	
19	3/4	1	-1216	<b>T6170-1216</b>	2.32	59	4.37	111	2.36	60	
25	1	1	-1616	<b>T6170-1616</b>	2.87	73	5.47	139	2.68	68	
25	1	1.1/4	-1620	<b>T6170-1620</b>	2.87	73	5.47	139	2.72	69	
31	1.1/4	1.1/4	-2020	<b>T6170-2020</b>	3.94	100	6.61	168	3.07	78	
38	1.1/2	1.1/2	-2424	<b>T6170-2424</b>	4.09	104	7.56	192	3.66	93	
51	2	2	-3232	<b>T6170-3232</b>	5.39	137	9.53	242	5.12	130	

**NOTE:** Hose Compatibility for the **T6000** series can be found on page 250

## T6000 SERIES ONE-PIECE CRIMP COUPLINGS

INTRODUCTION

HOSE

COUPLINGS

ADAPTORS

TECHNICAL

SAE FLANGE	T6330	T6333	T6334
------------	-------	-------	-------

RYCO  
CODE 62  
CLAMPS - SEE RYCO  
ADAPTOR CATALOGUE  
O RING NOT SUPPLIED

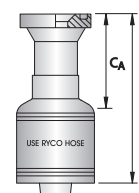
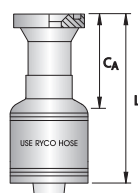
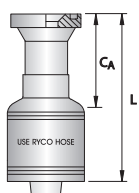

DN	HOSE SIZE			DASH SIZE	RYCO CODE 62 FLANGE				RYCO CODE 62C FLANGE				CODE 62C D-RING FLANGE					
	inch	inch	inch		PART NO	CA	L		PART NO	CA	L		PART NO	CA	L			
	inch	inch			inch	mm	inch	mm	inch	mm	inch	mm	inch	mm	inch	mm		
19	3/4	3/4	-1212	<b>T6330-1212</b>	2.09	53	4.13	105	<b>T6333-1212</b>	3.46	88	5.51	140	<b>T6334-1212</b>	2.52	64	4.57	116
19	3/4	1	-1216	<b>T6330-1216</b>	2.20	56	4.25	108	<b>T6333-1216</b>	3.46	88	5.51	140	<b>T6334-1216</b>	2.52	64	4.57	116
25	1	3/4	-1612	<b>T6330-1612</b>	2.13	54	4.72	120										
25	1	1	-1616	<b>T6330-1616</b>	2.24	57	4.84	123	<b>T6333-1616</b>	3.54	90	6.14	156	<b>T6334-1616</b>	2.56	65	5.16	131
25	1	1.1/4	-1620	<b>T6330-1620</b>	2.72	69	5.28	134	<b>T6333-1620</b>	3.54	90	6.14	156	<b>T6334-1620</b>	2.87	73	5.47	139
31	1.1/4	1	-2016	<b>T6330-2016</b>	2.80	71	5.47	139										
31	1.1/4	1.1/4	-2020	<b>T6330-2020</b>	2.80	71	5.47	139	<b>T6333-2020</b>	3.50	89	6.18	157	<b>T6334-2020</b>	3.66	93	6.34	161
31	1.1/4	1.1/2	-2024	<b>T6330-2024</b>	2.76	70	6.22	158	<b>T6333-2024</b>	3.43	87	6.10	155	<b>T6334-2024</b>	3.50	89	6.18	157
38	1.1/2	1.1/4	-2420	<b>T6330-2420</b>	2.76	70	6.22	158										
38	1.1/2	1.1/2	-2424	<b>T6330-2424</b>	3.98	101	7.40	188	<b>T6333-2424</b>	3.43	87	6.89	175	<b>T6334-2424</b>	3.31	84	6.77	172
38	1.1/2	2	-2432	<b>T6330-2432</b>	4.69	119	8.11	206	<b>T6333-2432</b>									
51	2	1.1/2	-3224	<b>T6330-3224</b>	4.21	107	8.35	212	<b>T6333-3232</b>	4.37	111	8.50	216	<b>T6334-3232</b>	4.92	125	9.02	229
51	2	2	-3232	<b>T6330-3232</b>	4.84	123	8.98	228										

SAE FLANGE	T6335	T6912
------------	-------	-------

RYCO  
CODE 62  
CLAMPS - SEE RYCO  
ADAPTOR CATALOGUE  
O RING NOT SUPPLIED

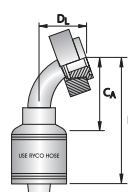
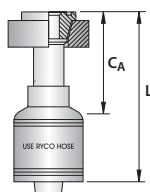

DN	HOSE SIZE			DASH SIZE	RYCO CODE 62K FLANGE				CODE 62 FLANGE 15° BEND				DL		
	inch	inch	inch		PART NO	CA	L		PART NO	CA	L		inch	mm	
	inch	inch			inch	mm	inch	mm	inch	mm	inch	mm	inch	mm	
25	1		-1616	<b>T6335-1616</b>	2.64	67	5.24	133	<b>T6912-1616</b>	4.92	125	7.52	191	0.67	17
25	1	1.1/4	-1620	<b>T6335-1620</b>	2.40	61	5.00	127							
31	1.1/4		-2016	<b>T6335-2016</b>	4.53	115	7.20	183							
31	1.1/4	1.1/4	-2020	<b>T6335-2020</b>	3.74	95	6.42	163							
31	1.1/4	1.1/2	-2024	<b>T6335-2024</b>	3.43	87	6.10	155	<b>T6912-2024</b>	6.54	166	9.21	234	0.71	18
38	1.1/2	1.1/2	-2424	<b>T6335-2424</b>	4.21	107	7.68	195	<b>T6912-2424</b>	7.64	194	11.06	281	0.94	24
38	1.1/2	2	-2432	<b>T6335-2432</b>	3.62	92	7.05	179	<b>T6912-2432</b>	7.68	195	11.10	282	1.06	27
51	2	1.1/2	-3224	<b>T6335-3224</b>	5.79	147	9.92	252							
51	2	2	-3232	<b>T6335-3232</b>	4.80	122	8.94	227							

**NOTE:** Hose Compatibility for the **T6000** series can be found on page 250

# COUPLINGS

## T6000 SERIES ONE-PIECE CRIMP COUPLINGS

<b>SAE FLANGE</b>	<b>T6440</b>
-------------------	--------------

RYCO  
CODE 62  
CLAMPS - SEE RYCO  
ADAPTOR CATALOGUE  
O RING NOT SUPPLIED

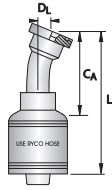

HOSE SIZE		NOM. FLANGE SIZE	DASH SIZE	CODE 62 FLANGE 22.5° BEND						
DN	inch	inch		PART NO	CA		L		DL	
					inch	mm	inch	mm	inch	mm
19	3/4	3/4	-1212	<b>T6440-1212</b>	3.15	80	5.20	132	0.63	16
19	3/4	1	-1216	<b>T6440-1216</b>	3.11	79	5.16	131	0.55	14
25	1	1	-1616	<b>T6440-1616</b>	3.58	91	6.18	157	0.63	16
31	1.1/4	1.1/4	-2020	<b>T6440-2020</b>	4.33	110	7.01	178	0.67	17
31	1.1/4	1.1/2	-2024	<b>T6440-2024</b>	4.65	118	7.32	186	0.87	22
38	1.1/2	1.1/2	-2424	<b>T6440-2424</b>	5.00	127	8.46	215	0.94	24
51	2	2	-3232	<b>T6440-3232</b>	6.57	167	10.71	272	1.10	28

<b>SAE FLANGE</b>	<b>T6445</b>	<b>T6443</b>
-------------------	--------------	--------------

RYCO  
CODE 62  
CLAMPS - SEE RYCO  
ADAPTOR CATALOGUE  
O RING NOT SUPPLIED

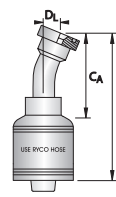
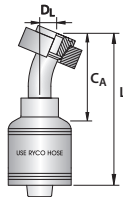

HOSE SIZE		NOM. FLANGE SIZE	DASH SIZE	RYCO CODE 62C FLANGE 22.5° BEND						RYCO CODE 62C FLANGE 22.5° BEND							
DN	inch	inch		PART NO	CA		L		DL		PART NO	CA		L		DL	
					inch	mm	inch	mm	inch	mm		inch	mm	inch	mm	inch	mm
19	3/4	3/4	-1212								<b>T6443-1212</b>	3.23	82	5.28	134	0.71	18
19	3/4	1	-1216								<b>T6443-1216</b>	3.35	85	5.39	137	0.79	20
25	1	1	-1616								<b>T6443-1616</b>	3.74	95	6.34	161	0.63	16
25	1	1.1/4	-1620								<b>T6443-1620</b>	3.78	96	6.38	162	0.75	19
31	1.1/4	1.1/4	-2020								<b>T6443-2020</b>	4.49	114	7.17	182	0.75	19
31	1.1/4	1.1/2	-2024								<b>T6443-2024</b>	4.65	118	7.32	186	0.87	22
38	1.1/2	1.1/2	-2424								<b>T6443-2424</b>	5.00	127	8.46	215	0.94	24
51	2	2	-3232	<b>T6445-3232</b>	8.62	219	12.76	324	1.77	45							

**NOTE:** Hose Compatibility for the **T6000** series can be found on page 250

## T6000 SERIES ONE-PIECE CRIMP COUPLINGS

<b>SAE FLANGE</b>	<b>T6444</b>	<b>T6450</b>
-------------------	--------------	--------------

RYCO  
CODE 62  
CLAMPS - SEE RYCO  
ADAPTOR CATALOGUE  
O RING NOT SUPPLIED

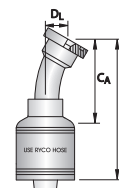
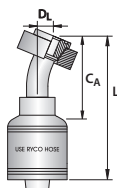

HOSE SIZE				NOM. FLANGE SIZE	DASH SIZE	CODE 62C D-RING FLANGE 22.5° BEND						CODE 62 FLANGE 30° BEND					
DN	inch	inch		PART NO	CA		L		DL		PART NO	CA		L		DL	
					inch	mm	inch	mm	inch	mm		inch	mm	inch	mm	inch	mm
19	3/4	3/4	-1212	<b>T6444-1212</b>	3.19	81	5.24	133	0.59	15	<b>T6450-1212</b>	2.87	73	4.92	125	0.75	19
25	1	1	-1616	<b>T6444-1616</b>	3.50	89	6.10	155	0.63	16	<b>T6450-1616</b>	3.54	90	6.14	156	0.87	22
25	1	1.1/4	-1620	<b>T6444-1620</b>	3.66	93	6.26	159	0.63	16	<b>T6450-1620</b>	3.54	90	6.14	156	0.98	25
31	1.1/4	1.1/4	-2020	<b>T6444-2020</b>	4.49	114	7.17	182	0.75	19	<b>T6450-2020</b>	4.33	110	7.01	178	0.87	22
31	1.1/4	1.1/2	-2024								<b>T6450-2024</b>	4.53	115	7.20	183	0.98	25
38	1.1/2	1.1/2	-2424								<b>T6450-2424</b>	5.31	135	8.78	223	1.30	33
51	2	2	-3232								<b>T6450-3232</b>	6.54	166	10.67	271	1.57	40

<b>SPECIAL FLANGE</b>	<b>T6453</b>	<b>T6454</b>
-----------------------	--------------	--------------

RYCO  
CODE 62  
CLAMPS - SEE RYCO  
ADAPTOR CATALOGUE  
O RING NOT SUPPLIED

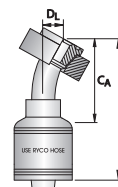
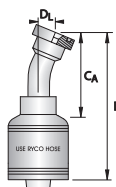

HOSE SIZE				NOM. FLANGE SIZE	DASH SIZE	CODE 62C D-RING FLANGE 30° BEND						RYCO CODE 62K FLANGE 30° BEND					
DN	inch	inch		PART NO	CA		L		DL		PART NO	CA		L		DL	
					inch	mm	inch	mm	inch	mm		inch	mm	inch	mm	inch	mm
19	3/4	3/4	-1212	<b>T6453-1212</b>	3.11	79	5.16	131	0.91	23	<b>T6454-1212</b>	3.23	82	5.28	134	0.91	23
25	1	1	-1616	<b>T6453-1616</b>	4.37	111	6.97	177	0.94	24	<b>T6454-1616</b>	4.25	108	6.85	174	0.94	24
25	1	1.1/4	-1620	<b>T6453-1620</b>	4.49	114	7.09	180	0.98	25							
31	1.1/4	1.1/4	-2020	<b>T6453-2020</b>	4.65	118	7.32	186	0.98	25	<b>T6454-2020</b>	4.61	117	7.28	185	0.98	25
31	1.1/4	1.1/2	-2024	<b>T6453-2024</b>	4.61	117	7.28	185	1.02	26	<b>T6454-2024</b>	4.61	117	7.28	185	1.02	26
38	1.1/2	1.1/2	-2424	<b>T6453-2424</b>	5.00	127	8.46	215	1.18	30							

**NOTE:** Hose Compatibility for the **T6000** series can be found on page 250

# COUPLINGS

## T6000 SERIES ONE-PIECE CRIMP COUPLINGS

<b>SPECIAL FLANGE</b>	<b>T6455</b>
-----------------------	--------------

RYCO  
CODE 62  
CLAMPS - SEE RYCO  
ADAPTOR CATALOGUE  
O RING NOT SUPPLIED

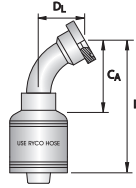

HOSE SIZE				NOM. FLANGE SIZE	DASH SIZE	CODE 62 FLANGE 60° BEND					
DN	inch	inch		PART NO	CA		L		DL		
					inch	mm	inch	mm	inch	mm	
31	1.1/4	1.1/4	-2020	<b>T6455-2020</b>	6.73	171	9.41	239	1.57	40	
31	1.1/4	1.1/2	-2024	<b>T6455-2024</b>	6.54	166	9.21	234	1.50	38	
38	1.1/2	1.1/2	-2424	<b>T6455-2424</b>	7.24	184	10.67	271	1.97	50	
51	2	2	-3232	<b>T6455-3232</b>	8.39	213	12.52	318	2.17	55	

<b>SPECIAL FLANGE</b>	<b>T6350</b>	<b>T6353</b>
-----------------------	--------------	--------------

RYCO  
CODE 62  
CLAMPS - SEE RYCO  
ADAPTOR CATALOGUE  
O RING NOT SUPPLIED

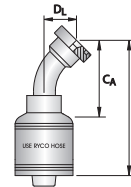
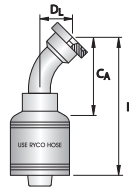

HOSE SIZE				NOM. FLANGE SIZE	DASH SIZE	CODE 62 FLANGE 45° BEND					RYCO CODE 62C FLANGE 45° BEND						
DN	inch	inch		PART NO	CA		L		DL		PART NO	CA		L		DL	
					inch	mm	inch	mm	inch	mm		inch	mm	inch	mm	inch	mm
19	3/4	3/4	-1212	<b>T6350-1212</b>	2.72	69	4.76	121	1.10	28	<b>T6353-1212</b>	2.83	72	4.88	124	1.22	31
19	3/4	1	-1216	<b>T6350-1216</b>	2.87	73	4.92	125	1.22	31	<b>T6353-1216</b>	2.83	72	4.88	124	1.30	33
25	1	3/4	-1612	<b>T6350-1612</b>	2.83	72	5.43	138	1.10	28							
25	1	1	-1616	<b>T6350-1616</b>	3.31	84	5.91	150	1.22	31	<b>T6353-1616</b>	3.43	87	6.02	153	1.38	35
25	1	1.1/4	-1620	<b>T6350-1620</b>	3.35	85	5.94	151	1.34	34	<b>T6353-1620</b>	3.31	84	5.91	150	1.46	37
31	1.1/4	1.1/4	-2020	<b>T6350-2020</b>	4.06	103	6.73	171	1.50	38	<b>T6353-2020</b>	4.17	106	6.85	174	1.61	41
31	1.1/4	1.1/2	-2024	<b>T6350-2024</b>	4.17	106	6.85	174	1.61	41	<b>T6353-2024</b>	4.33	110	7.01	178	1.65	42
38	1.1/2	1.1/2	-2424	<b>T6350-2424</b>	4.45	113	7.91	201	1.77	45	<b>T6353-2424</b>	4.53	115	7.99	203	1.81	46
38	1.1/2	2	-2432	<b>T6350-2432</b>	4.76	121	8.23	209	1.97	50							
51	2	2	-3232	<b>T6350-3232</b>	6.10	155	10.24	260	2.36	60	<b>T6353-3232</b>	6.34	161	10.47	266	2.40	61

**NOTE:** Hose Compatibility for the **T6000** series can be found on page 250

## T6000 SERIES ONE-PIECE CRIMP COUPLINGS

INTRODUCTION

HOSE

COUPLINGS

ADAPTORS

TECHNICAL

<b>SPECIAL FLANGE</b>	<b>T6354</b>	<b>T6355</b>
-----------------------	--------------	--------------

RYCO  
CODE 62  
CLAMPS - SEE RYCO  
ADAPTOR CATALOGUE  
O RING NOT SUPPLIED

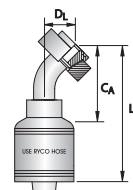
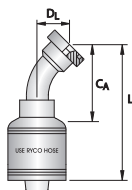

HOSE SIZE				NOM. FLANGE SIZE	DASH SIZE	RYCO CODE 62C D-RING FLANGE 45° BEND						RYCO CODE 62K FLANGE 45° BEND										
DN	inch	inch				PART NO		CA		L		DL		PART NO		CA		L		DL		
						inch	mm	inch	mm	inch	mm	inch	mm	inch	mm	inch	mm	inch	mm	inch	mm	
19	3/4	3/4	-1212	<b>T6354-1212</b>	2.80	71	4.84	123	1.22	31												
19	3/4	1	-1216	<b>T6354-1216</b>	2.91	74	4.96	126	1.30	33												
25	1	1	-1616	<b>T6354-1616</b>	3.58	91	6.18	157	1.38	35	<b>T6355-1616</b>	4.25	108	6.85	174	1.97	50					
25	1	1.1/4	-1620	<b>T6354-1620</b>	3.23	82	5.83	148	1.46	37	<b>T6355-1620</b>	4.21	107	6.81	173	1.97	50					
31	1.1/4	1	-2016								<b>T6355-2016</b>	6.02	153	8.70	221	2.17	55					
31	1.1/4	1.1/4	-2020	<b>T6354-2020</b>	4.17	106	6.85	174	1.73	44	<b>T6355-2020</b>	6.22	158	8.90	226	2.36	60					
31	1.1/4	1.1/2	-2024	<b>T6354-2024</b>	4.33	110	7.01	178	1.69	43	<b>T6355-2024</b>	6.61	168	9.29	236	2.36	60					
38	1.1/2	1.1/4	-2420								<b>T6355-2420</b>	6.34	161	9.80	249	2.87	73					
38	1.1/2	1.1/2	-2424								<b>T6355-2424</b>	6.57	167	10.00	254	3.15	80					
38	1.1/2	2	-2432								<b>T6355-2432</b>	6.22	158	9.65	245	3.74	95					
51	2	1.1/2	-3224								<b>T6355-3224</b>	5.79	147	9.92	252	3.35	85					
51	2	2	-3232								<b>T6355-3232</b>	7.60	193	11.73	298	3.54	90					

<b>SPECIAL FLANGE</b>	<b>T6359</b>	<b>T6465</b>
-----------------------	--------------	--------------

RYCO  
CODE 62  
CLAMPS - SEE PAGES  
440 & 441  
O RING NOT SUPPLIED

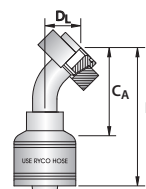
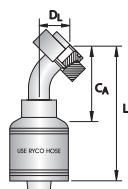

HOSE SIZE				NOM. FLANGE SIZE	DASH SIZE	RYCO CODE 62K D-RING FLANGE 45° TUBE BEND						RYCO CODE 62K FLANGE 90° TUBE BEND										
DN	inch	inch				PART NO		CA		L		DL		PART NO		CA		L		DL		
						inch	mm	inch	mm	inch	mm	inch	mm	inch	mm	inch	mm	inch	mm	inch	mm	
38	1.1/2	1.1/2	-2424											<b>T6465-2424</b>	7.87	200	11.30	287	3.70	94		
51	2	2	-3232	<b>T6359-3232</b>	9.76	248	13.90	353	5.31	135	<b>T6465-3232</b>	9.49	241	13.62	346	4.72	120					

**NOTE:** Hose Compatibility for the **T6000** series can be found on page 250



# COUPLINGS

## T6000 SERIES ONE-PIECE CRIMP COUPLINGS

### SPECIAL FLANGE

### T6360

RYCO  
CODE 62  
CLAMPS - SEE PAGES  
440 & 441  
O RING NOT SUPPLIED

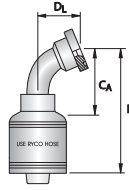

HOSE SIZE		NOM. FLANGE SIZE	DASH SIZE	CODE 62 FLANGE 67.5° BEND						
DN	inch	inch		PART NO	CA		L		DL	
					inch	mm	inch	mm	inch	mm
19	3/4	3/4	-1212	<b>T6360-1212</b>	2.91	74	4.96	126	1.85	47
19	3/4	1	-1216	<b>T6360-1216</b>	3.03	77	5.08	129	1.73	44
25	1	1	-1616	<b>T6360-1616</b>	3.58	91	6.18	157	2.01	51
25	1	1.1/4	-1620	<b>T6360-1620</b>	3.74	95	6.34	161	2.83	72
31	1.1/4	1.1/4	-2020	<b>T6360-2020</b>	5.28	134	7.95	202	2.83	72
31	1.1/4	1.1/2	-2024	<b>T6360-2024</b>	5.43	138	8.11	206	2.91	74

### SPECIAL FLANGE

### T6914

### T6916

RYCO  
CODE 62C  
CLAMPS - SEE PAGES  
440 & 441  
O RING NOT SUPPLIED

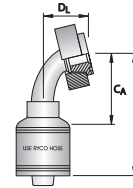
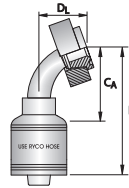

HOSE SIZE		NOM. FLANGE SIZE	DASH SIZE	RYCO CODE 62K FLANGE 70° BEND							RYCO CODE 62K F FLANGE 75° BEND						
DN	inch	inch		PART NO	CA		L		DL		PART NO	CA		L		DL	
					inch	mm	inch	mm	inch	mm		inch	mm	inch	mm	inch	mm
25	1	1	-1616	<b>T6914-1616</b>	4.53	115	7.13	181	2.76	70							
31	1.1/4	1.1/4	-2020	<b>T6914-2020</b>	6.65	169	9.33	237	3.78	96							
38	1.1/2	2	-2432								<b>T6916-2432</b>	6.97	177	10.39	264	5.43	138

**NOTE:** Hose Compatibility for the **T6000** series can be found on page 250

## T6000 SERIES ONE-PIECE CRIMP COUPLINGS

<b>SPECIAL FLANGE</b>	<b>T6918</b>	<b>T6363</b>
-----------------------	--------------	--------------

RYCO  
CODE 62C  
CLAMPS - SEE PAGES  
440 & 441  
O RING NOT SUPPLIED

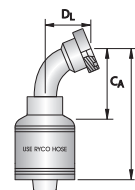
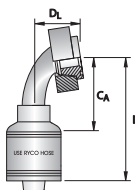

HOSE SIZE				NOM. FLANGE SIZE	DASH SIZE	RYCO CODE 62K FLANGE 80° BEND					RYCO CODE 62C FLANGE 67.5° BEND						
DN	inch	inch		PART NO	CA		L		DL		PART NO	CA		L		DL	
					inch	mm	inch	mm	inch	mm		inch	mm	inch	mm	inch	mm
19	3/4	3/4	-1212								<b>T6363-1212</b>	2.95	75	5.00	127	2.05	52
19	3/4	1	-1216								<b>T6363-1216</b>	2.99	76	5.04	128	2.09	53
25	1	1	-1616								<b>T6363-1616</b>	3.58	91	6.18	157	2.09	53
25	1	1.1/4	-1620								<b>T6363-1620</b>	3.62	92	6.22	158	2.20	56
31	1.1/4	1.1/4	-2020								<b>T6363-2020</b>	4.57	116	7.24	184	2.64	67
31	1.1/4	1.1/2	-2024								<b>T6363-2024</b>	4.25	108	6.93	176	2.99	76
38	1.1/2	1.1/2	-2424								<b>T6363-2424</b>	5.39	137	8.86	225	3.03	77
51	2	2	-3232	<b>T6918-3232</b>	7.56	192	11.69	297	6.30	160							

<b>SPECIAL FLANGE</b>	<b>T6364</b>
-----------------------	--------------

RYCO  
CODE 62C  
CLAMPS - SEE PAGES  
440 & 441  
O RING NOT SUPPLIED

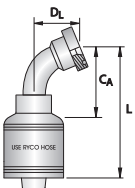

HOSE SIZE				NOM. FLANGE SIZE	DASH SIZE	CODE 62C D-RING FLANGE 67.5° BEND				
DN	inch	inch		PART NO	CA		L		DL	
					inch	mm	inch	mm	inch	mm
19	3/4	3/4	-1212	<b>T6364-1212</b>	2.95	75	5.00	127	2.05	52
19	3/4	1	-1216	<b>T6364-1216</b>	3.11	79	5.16	131	2.09	53
25	1	1	-1616	<b>T6364-1616</b>	3.58	91	6.18	157	2.09	53
25	1	1.1/4	-1620	<b>T6364-1620</b>	3.62	92	6.22	158	2.20	56
31	1.1/4	1.1/4	-2020	<b>T6364-2020</b>	4.45	113	7.13	181	2.64	67
31	1.1/4	1.1/2	-2024	<b>T6364-2024</b>	4.25	108	6.93	176	2.99	76

**NOTE:** Hose Compatibility for the **T6000** series can be found on page 271

# COUPLINGS

## T6000 SERIES ONE-PIECE CRIMP COUPLINGS

<b>SPECIAL FLANGE</b>	<b>T6374</b>	<b>T6460</b>
-----------------------	--------------	--------------

RYCO  
CODE 62C  
CLAMPS - SEE PAGES  
440 & 441  
O RING NOT SUPPLIED

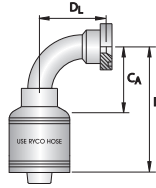

HOSE SIZE	NOM. FLANGE SIZE	DASH SIZE	CODE 62C D-RING FLANGE 90° BEND								RYCO CODE 62C FLANGE 60° BEND							
			PART NO		CA		L		DL		PART NO		CA		L		DL	
DN	inch	inch			inch	mm	inch	mm	inch	mm			inch	mm	inch	mm		
19	3/4	3/4	-1212	<b>T6374-1212</b>	2.32	59	4.37	111	2.44	62	<b>T6460-1212</b>	3.23	82	5.28	134	1.42	36	
19	3/4	1	-1216	<b>T6374-1216</b>	2.32	59	4.37	111	2.60	66	<b>T6460-1216</b>	3.23	82	5.28	134	1.50	38	
25	1	1	-1616	<b>T6374-1616</b>	2.87	73	5.47	139	2.83	72	<b>T6460-1616</b>	3.86	98	6.46	164	1.73	44	
25	1	1.1/4	-1620	<b>T6374-1620</b>	2.87	73	5.47	139	2.95	75	<b>T6460-1620</b>	3.90	99	6.50	165	1.81	46	
31	1.1/4	1.1/4	-2020	<b>T6374-2020</b>	3.94	100	6.61	168	3.27	83	<b>T6460-2020</b>	4.02	102	6.69	170	1.97	50	
31	1.1/4	1.1/2	-2024	<b>T6374-2024</b>	3.94	100	6.61	168	3.35	85	<b>T6460-2024</b>	4.92	125	7.60	193	2.28	58	
38	1.1/2	1.1/2	-2424								<b>T6460-2424</b>	6.14	156	9.61	244	2.80	71	
38	1.1/2	2	-2432								<b>T6460-2432</b>	6.30	160	9.76	248	3.11	79	
51	2	2	-3232								<b>T6460-3232</b>	8.70	221	12.83	326	3.98	101	

<b>SPECIAL FLANGE</b>	<b>T6463</b>	<b>T6464</b>
-----------------------	--------------	--------------

RYCO  
CODE 62C  
CLAMPS - SEE PAGES  
440 & 441  
O RING NOT SUPPLIED

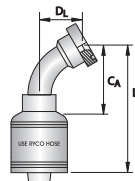
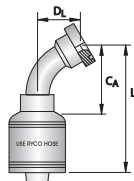

HOSE SIZE	NOM. FLANGE SIZE	DASH SIZE	CODE 62C FLANGE 60° BEND								RYCO CODE 62C FLANGE 90° BEND							
			PART NO		CA		L		DL		PART NO		CA		L		DL	
DN	inch	inch			inch	mm	inch	mm	inch	mm			inch	mm	inch	mm		
19	3/4	3/4	-1212	<b>T6463-1212</b>	3.23	82	5.28	134	1.81	46	<b>T6464-1212</b>	3.31	84	5.35	136	1.65	42	
19	3/4	1	-1216	<b>T6463-1216</b>	3.46	88	5.51	140	1.65	42	<b>T6464-1216</b>	3.31	84	5.35	136	1.65	42	
25	1	1	-1616	<b>T6463-1616</b>	3.90	99	6.50	165	1.85	47	<b>T6464-1616</b>	3.82	97	6.42	163	1.85	47	
25	1	1.1/4	-1620	<b>T6463-1620</b>	4.09	104	6.69	170	1.93	49	<b>T6464-1620</b>	3.98	101	6.57	167	1.93	49	
31	1.1/4	1.1/4	-2020	<b>T6463-2020</b>	4.84	123	7.52	191	2.20	56	<b>T6464-2020</b>	4.80	122	7.48	190	2.20	56	
31	1.1/4	1.1/2	-2024	<b>T6463-2024</b>	5.83	148	8.50	216	2.60	66	<b>T6464-2024</b>	5.75	146	8.43	214	2.60	66	
38	1.1/2	1.1/2	-2424	<b>T6463-2424</b>	5.71	145	9.17	233	2.68	68								

**NOTE:** Hose Compatibility for the **T6000** series can be found on page 271

## T6000 SERIES ONE-PIECE CRIMP COUPLINGS

<b>SPECIAL FLANGE</b>	<b>T6375</b>	<b>T6370</b>
-----------------------	--------------	--------------

RYCO  
CODE 62C  
CLAMPS - SEE RYCO  
ADAPTOR CATALOGUE  
O RING NOT SUPPLIED

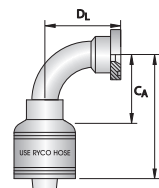
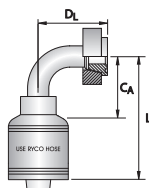

HOSE SIZE				NOM. FLANGE SIZE	DASH SIZE	RYCO CODE 62K FLANGE 90° BEND					CODE 62 FLANGE 90° BEND						
DN	inch	inch		PART NO	CA		L		DL		PART NO	CA		L		DL	
					inch	mm	inch	mm	inch	mm		inch	mm	inch	mm	inch	mm
19	3/4	3/4	-1212								<b>T6370-1212</b>	2.32	59	4.37	111	2.20	56
19	3/4	1	-1216								<b>T6370-1216</b>	2.32	59	4.37	111	2.40	61
25	1	3/4	-1612								<b>T6370-1612</b>	2.36	60	4.96	126	2.20	56
25	1	1	-1616	<b>T6375-1616</b>	3.43	87	6.02	153	3.54	90	<b>T6370-1616</b>	2.87	73	5.47	139	2.76	70
25	1	1.1/4	-1620	<b>T6375-1620</b>	3.43	87	6.02	153	3.94	100	<b>T6370-1620</b>	2.87	73	5.47	139	2.80	71
31	1.1/4	1	-2016	<b>T6375-2016</b>	5.08	129	7.76	197	4.53	115	<b>T6370-2016</b>	3.11	79	5.79	147	2.76	70
31	1.1/4	1.1/4	-2020	<b>T6375-2020</b>	5.16	131	7.83	199	4.72	120	<b>T6370-2020</b>	3.94	100	6.61	168	3.15	80
31	1.1/4	1.1/2	-2024	<b>T6375-2024</b>	5.16	131	7.83	199	4.72	120	<b>T6370-2024</b>	3.94	100	6.61	168	3.39	86
38	1.1/2	1.1/4	-2420	<b>T6375-2420</b>	5.28	134	8.74	222	4.72	120							
38	1.1/2	1.1/2	-2424	<b>T6375-2424</b>	5.43	138	8.86	225	5.51	140	<b>T6370-2424</b>	3.90	99	7.36	187	3.86	98
38	1.1/2	2	-2432	<b>T6375-2432</b>	5.43	138	8.86	225	6.30	160	<b>T6370-2432</b>	4.09	104	7.56	192	4.09	104
51	2	1.1/2	-3224	<b>T6375-3224</b>	5.75	146	9.88	251	5.51	140							
51	2	2	-3232	<b>T6375-3232</b>	6.38	162	10.51	267	7.09	180	<b>T6370-3232</b>	6.50	165	10.63	270	5.16	131

<b>SPECIAL FLANGE</b>	<b>T6373</b>	<b>T6375</b>
-----------------------	--------------	--------------

RYCO  
CODE 62C  
CLAMPS - SEE RYCO  
ADAPTOR CATALOGUE  
O RING NOT SUPPLIED

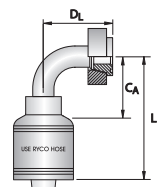
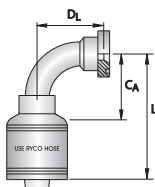

HOSE SIZE				NOM. FLANGE SIZE	DASH SIZE	RYCO CODE 62C FLANGE 90° BEND					RYCO CODE 62K FLANGE 90° BEND						
DN	inch	inch		PART NO	CA		L		DL		PART NO	CA		L		DL	
					inch	mm	inch	mm	inch	mm		inch	mm	inch	mm	inch	mm
19	3/4	3/4	-1212	<b>T6373-1212</b>	2.32	59	4.37	111	2.44	62							
19	3/4	1	-1216	<b>T6373-1216</b>	2.32	59	4.37	111	2.56	65							
25	1	1	-1616	<b>T6373-1616</b>	2.87	73	5.47	139	2.91	74	<b>T6375-1616</b>	3.43	87	6.02	153	3.54	90
25	1	1.1/4	-1620	<b>T6373-1620</b>	2.87	73	5.47	139	2.95	75	<b>T6375-1620</b>	3.43	87	6.02	153	3.94	100
31	1.1/4	1	-2016								<b>T6375-2016</b>	5.08	129	7.76	197	4.53	115
31	1.1/4	1.1/4	-2020	<b>T6373-2020</b>	3.94	100	6.61	168	3.27	83	<b>T6375-2020</b>	5.16	131	7.83	199	4.72	120
31	1.1/4	1.1/2	-2024	<b>T6373-2024</b>	3.94	100	6.61	168	3.35	85	<b>T6375-2024</b>	5.16	131	7.83	199	4.72	120
38	1.1/2	1.1/4	-2420								<b>T6375-2420</b>	5.28	134	8.74	222	4.72	120
38	1.1/2	1.1/2	-2424	<b>T6373-2424</b>	4.21	107	7.68	195	3.94	100	<b>T6375-2424</b>	5.43	138	8.86	225	5.51	140
38	1.1/2	2	-2432								<b>T6375-2432</b>	5.43	138	8.86	225	6.30	160
51	2	1.1/2	-3224								<b>T6375-3224</b>	5.75	146	9.88	251	5.51	140
51	2	2	-3232	<b>T6373-3232</b>	5.59	142	9.72	247	5.24	133	<b>T6375-3232</b>	6.38	162	10.51	267	7.09	180

**NOTE:** Hose Compatibility for the **T6000** series can be found on page 271

INTRODUCTION

HOSE

COUPLINGS

ADAPTORS

TECHNICAL

# COUPLINGS

## T6000 SERIES ONE-PIECE CRIMP COUPLINGS

<b>SPECIAL FLANGE</b>	<b>T6936</b>	<b>T6932</b>
-----------------------	--------------	--------------

RYCO  
CODE 62C  
CLAMPS - SEE RYCO  
ADAPTOR CATALOGUE  
O RING NOT SUPPLIED

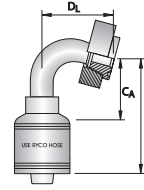
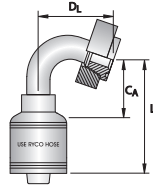

HOSE SIZE		NOM. FLANGE SIZE	DASH SIZE	RYCO CODE 62K FLANGE 100° BEND						RYCO CODE 62K FLANGE 100° BEND									
DN	inch	inch		PART NO		CA		L		DL		PART NO		CA		L		DL	
				inch	mm	inch	mm	inch	mm	inch	mm	inch	mm	inch	mm	inch	mm	inch	mm
31	1.1/4	1.1/4	-2020	<b>T6936-2020</b>	4.72	120	7.40	188	4.92	125									
51	2	2	-3232	<b>T6936-3232</b>	5.08	129	9.21	234	7.87	200									
38	1.1/2	1.1/2	-2424								<b>T6932-2424</b>	3.90	99	7.32	186	6.18	157		

<b>SPECIAL FLANGE</b>	<b>T6930</b>	<b>T6933</b>
-----------------------	--------------	--------------

RYCO  
CODE 62C  
CLAMPS - SEE RYCO  
ADAPTOR CATALOGUE  
O RING NOT SUPPLIED

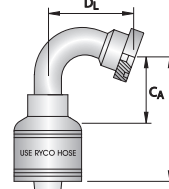
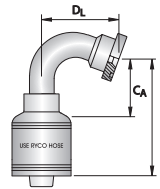

HOSE SIZE		NOM. FLANGE SIZE	DASH SIZE	CODE 62 FLANGE 110° BEND						RYCO CODE 62C FLANGE 110° BEND									
DN	inch	inch		PART NO		CA		L		DL		PART NO		CA		L		DL	
				inch	mm	inch	mm	inch	mm	inch	mm	inch	mm	inch	mm	inch	mm	inch	mm
38	1.1/2	1.1/2	-2424	<b>T6930-2424</b>	5.59	142	9.02	229	4.69	119	<b>T6933-2424</b>	5.55	141	9.02	229	4.72	120		
38	1.1/2	2	-2432	<b>T6930-2432</b>	5.63	143	9.09	231	4.80	122									
51	2	2	-3232	<b>T6930-3232</b>	6.14	156	10.28	261	5.63	143	<b>T6933-3232</b>	4.57	116	8.70	221	5.35	136		

**NOTE:** Hose Compatibility for the **T6000** series can be found on page 271

## T6000 SERIES ONE-PIECE CRIMP COUPLINGS

<b>HAMMER UNION</b>	<b>T61502</b>	<b>T61501</b>
---------------------	---------------	---------------

**FIGURE 1502  
STANDARD SERVICE**

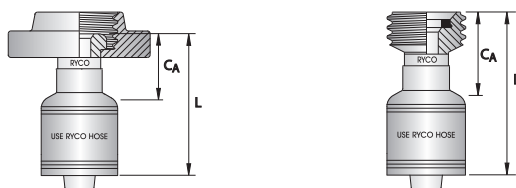

HOSE SIZE		NOM. FLANGE SIZE	DASH SIZE	FIGURE 1502 HAMMER/WING FEMALE STANDARD SERVICE				FIGURE 1502 HAMMER/WING MALE STANDARD SERVICE					
DN	inch	inch		PART NO	CA		L		PART NO	CA		L	
					inch	mm	inch	mm		inch	mm	inch	mm
38	1.1/2	2	-2432	<b>T61502-2432</b>	4.41	112	7.83	199	<b>T61501-2432</b>	3.62	92	7.09	180
51	2	2	-3232	<b>T61502-3232</b>	4.57	116	8.70	221	<b>T61501-3232</b>	3.82	97	7.95	202

INTRODUCTION

HOSE

COUPLINGS

ADAPTORS

TECHNICAL

**NOTE:** Hose Compatibility for the **T6000** series can be found on page 271



# COUPLINGS

## T7000 SERIES ONE-PIECE CRIMP COUPLINGS

### HOSE COMPATIBILITY FOR T7000 SERIES

#### NON-SKIVE

For RYCO Hose Series H3000D/S (sizes -20 to -32).  
 For RYCO Hose Series H4000D/S (sizes -06 to -32).  
 For RYCO Hose Series H5000D/S (sizes -06 to -24).  
 For RYCO Hose Series H6000D/S (sizes -06 to -20).  
 For RYCO Hose Series T2D/S/C (sizes -06 to -32).  
 For RYCO Hose Series E2, HSPD (sizes -06 to -16).  
 For RYCO Hose Series H12D/S (sizes -06 to -20).  
 For RYCO Hose Series R45H, HSHD (sizes -20 to -32).  
 For RYCO Hose Series T2, TXA2D, RQP2 (sizes -06 to -32).  
 For RYCO Hose Series D2B (sizes -24 to -32).  
 For RYCO Hose Series R45P (cover must be skived) (all sizes).

#### SKIVE

For RYCO Hose Series R4SPD (cover must be skived) all sizes.

BSPT	T7010	T7014
------	-------	-------

60° SEAT

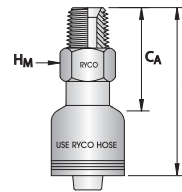
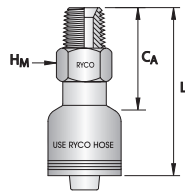

HOSE SIZE		THRD SIZE	DASH SIZE	MALE HEX	BSPT MALE				BSPT MALE HEAVY DUTY						
DN	inch	inch		HM-SPANNER	PART NO	CA		L		PART NO	CA		L		
				inch	mm	inch	mm	inch	mm		inch	mm	inch	mm	
10	3/8	3/8	-0606	3/4	19	<b>T7010-0606</b>	1.38	35	2.56	65					
12	1/2	1/2	-0808	7/8	22	<b>T7010-0808</b>	1.65	42	2.72	69					
19	3/4	3/4	-1212	1.1/16	27	<b>T7010-1212</b>	1.85	47	3.07	78					
25	1	1	-1616		36	<b>T7010-1616</b>	2.09	53	3.78	96	<b>T7014-1616</b>	1.89	48	3.58	91
31	1.1/4	1.1/4	-2020		46	<b>T7010-2020</b>	2.36	60	4.37	111					
38	1.1/2	1.1/2	-2424	2	50	<b>T7010-2424</b>	2.17	55	4.37	111					
51	2	2	-3232		65	<b>T7010-3232</b>	2.60	66	5.08	129					

**NOTE:** Hose Compatibility for the **T7000** series can be found on page 272.

## T7000 SERIES ONE-PIECE CRIMP COUPLINGS

INTRODUCTION

HOSE

COUPLINGS

ADAPTORS

TECHNICAL

### BSPP T7013

60° SEAT

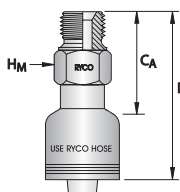

HOSE SIZE		THRD SIZE	DASH SIZE	MALE HEX		BSPP MALE					
DN	inch	inch		HM-SPANNER		PART NO	CA		L		
				inch	mm		inch	mm	inch	mm	
10	3/8	3/8	-0606	7/8	22	<b>T7013-0606</b>	1.46	37	2.60	66	
12	1/2	1/2	-0808	1.1/16	27	<b>T7013-0808</b>	1.61	41	2.72	69	
12	1/2	5/8	-0810	1.1/4	32	<b>T7013-0810</b>	1.73	44	2.80	71	
19	3/4	3/4	-1212	1.1/4	32	<b>T7013-1212</b>	1.85	47	3.07	78	
19	3/4	3/4	-1216	1.5/8	41	<b>T7013-1216</b>	2.01	51	3.23	82	
25	1	1	-1616	1.5/8	41	<b>T7013-1616</b>	2.01	51	3.70	94	
31	1.1/4	1.1/4	-2020	2	50	<b>T7013-2020</b>	2.36	60	4.37	111	
38	1.1/2	1.1/2	-2424	2.3/16	55	<b>T7013-2424</b>	2.17	55	4.37	111	
51	2	2	-3232	2.3/4	70	<b>T7013-3232</b>	2.64	67	5.12	130	

### BSPP T7020 T7022

60° SEAT

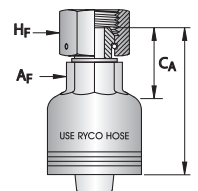
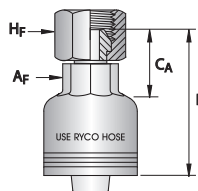

HOSE SIZE		THRD SIZE	DASH SIZE	BACK UP Af		FEMALE HEX		BSPP FEMALE				BSPP FEMALE HEAVY DUTY					
DN	inch	inch		Af-SPANNER		Hf-SPANNER		PART NO	CA		L		PART NO	CA		L	
				inch	mm	inch	mm		inch	mm	inch	mm		inch	mm	inch	mm
10	3/8	3/8	-0606	5/8	16	7/8	22	<b>T7020-0606</b>	1.02	26	2.20	56					
12	1/2	1/2	-0808	3/4	19	1.1/16	27	<b>T7020-0808</b>	1.10	28	2.20	56	<b>T7022-0808</b>	1.10	28	2.20	56
16	5/8	5/8	-1010	15/16	24	1.3/16	30	<b>T7020-1010</b>	1.14	29	2.40	61					
19	3/4	3/4	-1212	1.1/16	27	1.1/4	32	<b>T7020-1212</b>	1.30	33	2.52	64	<b>T7022-1212</b>	1.30	33	2.52	64
19	3/4	1	-1612					<b>T7020-1216</b>	1.54	39	2.76	70					
25	1	1	-1616	1.1/4	32	1.1/2	38	<b>T7020-1616</b>	1.50	38	3.19	81	<b>T7022-1616</b>	1.50	38	3.19	81
31	1.1/4	1	-2016	1.5/8	41	1.1/2	38	<b>T7020-2016</b>	1.73	44	3.74	95					
31	1.1/4	1.1/4	-2020	1.5/8	41	2	50	<b>T7020-2020</b>	1.77	45	3.78	96	<b>T7022-2020</b>	1.77	45	3.78	96
38	1.1/2	1.1/2	-2424	2	50	2.3/16	55	<b>T7020-2424</b>	1.85	47	4.06	103					
51	2	2	-3232		65	2.3/4	70	<b>T7020-3232</b>	2.17	55	4.61	117					

**NOTE:** T7000 BSPP, JIC, JIS and Metric Swivel Nut Couplings are shown as "Crimp Nut". Larger sizes are "Wire Nut" or "Slip Nut". See note on page 168.

**NOTE:** Hose Compatibility for the T7000 series can be found on page 272.

# COUPLINGS

## T7000 SERIES ONE-PIECE CRIMP COUPLINGS

<b>BSPP</b>	<b>T7060</b>	<b>T7050</b>
-------------	--------------	--------------

60° SEAT

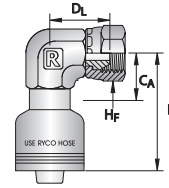
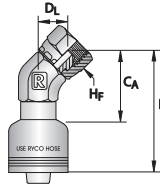

HOSE SIZE	THRD SIZE	DASH SIZE	FEMALE HEX	BSPP FEMALE 45° ELBOW								BSPP FEMALE 90° ELBOW									
				HF-SPANNER		PART NO	CA		L		DL		PART NO	CA		L		DL			
DN	inch	inch		inch	mm			inch	mm	inch	mm	inch		mm	inch	mm	inch	mm	inch	mm	
10	3/8	3/8	-0606	7/8	22										<b>T7050-0606</b>	1.22	31	2.36	60	1.10	28
12	1/2	1/2	-0808	1.1/16	27	<b>T7060-0808</b>	1.14	29	2.24	57	0.71	18	<b>T7050-0808</b>	1.46	37	2.56	65	1.22	31		
19	3/4	3/4	-1212	1.1/4	32	<b>T7060-1212</b>	1.34	34	2.52	64	0.79	20	<b>T7050-1212</b>	1.57	40	2.80	71	1.42	36		
25	1	1	-1616	1.1/2	38	<b>T7060-1616</b>	1.38	35	3.07	78	1.02	26	<b>T7050-1616</b>	1.54	39	3.23	82	1.77	45		
31	1.1/4	1.1/4	-2020	2	50	<b>T7060-2020</b>	1.46	37	3.46	88	1.14	29	<b>T7050-2020</b>	2.05	52	4.06	103	2.05	52		
38	1.1/2	1.1/2	-2424	2.3/16	55								<b>T7050-2424</b>	2.36	60	4.61	117	2.32	59		
51	2	2	-3232	2.3/4	70								<b>T7050-3232</b>	2.20	56	4.69	119	2.44	62		

**NOTE:** T7000 BSPP, JIC, JIS and Metric Swivel Nut Couplings are shown as "Crimp Nut". Larger sizes are "Wire Nut" or "Slip Nut". See note on page 168.

<b>BSPP</b>	<b>T7270</b>	<b>T7260</b>
-------------	--------------	--------------

60° SEAT

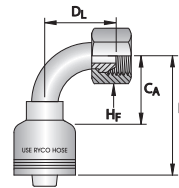
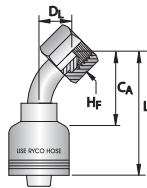

HOSE SIZE	THRD SIZE	DASH SIZE	FEMALE HEX	BSPP FEMALE 45° TUBE BEND								BSPP FEMALE 90° TUBE BEND							
				HF-SPANNER		PART NO	CA		L		DL		PART NO	CA		L		DL	
DN	inch	inch		inch	mm			inch	mm	inch	mm	inch		mm	inch	mm	inch	mm	inch
10	3/8	3/8	-0606	7/8	22	<b>T7270-0606</b>	1.61	41	2.80	71	0.71	18	<b>T7260-0606</b>	1.38	35	2.52	64	1.30	33
12	1/2	1/2	-0808	1.1/16	27	<b>T7270-0808</b>	1.97	50	3.07	78	0.87	22	<b>T7260-0808</b>	1.61	41	2.72	69	1.77	45
19	3/4	3/4	-1212	1.1/4	32	<b>T7270-1212</b>	3.11	79	4.33	110	1.14	29	<b>T7260-1212</b>	2.32	59	3.54	90	2.32	59
25	1	1	-1616	1.1/2	38	<b>T7270-1616</b>	3.35	85	5.04	128	1.65	42	<b>T7260-1616</b>	2.68	68	4.37	111	3.07	78
31	1.1/4	1	-2016	1.1/2	38								<b>T7260-2016</b>	3.54	90	5.55	141	3.03	77
31	1.1/4	1.1/4	-2020	2	50	<b>T7270-2020</b>	6.50	165	8.50	216	1.81	46	<b>T7260-2020</b>	3.94	100	5.94	151	3.58	91
38	1.1/2	1.1/2	-2424	2.3/16	55	<b>T7270-2424</b>	5.04	128	7.24	184	2.05	52	<b>T7260-2424</b>	4.17	106	6.38	162	4.13	105
51	2	2	-3232	2.3/4	70	<b>T7270-3232</b>	5.91	150	8.39	213	2.56	65	<b>T7260-3232</b>	5.39	137	7.87	200	5.20	132

**NOTE:** Hose Compatibility for the **T7000** series can be found on page 272.

## T7000 SERIES ONE-PIECE CRIMP COUPLINGS

### BSPP T7210

60° SEAT

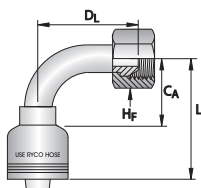

HOSE SIZE		THRD SIZE	DASH SIZE	FEMALE HEX		BSPP FEMALE 90° LONG BEND						
DN	inch	inch		inch	mm	PART NO	CA		L		DL	
							inch	mm	inch	mm	inch	mm
19	3/4	3/4	-1212	1.1/4	32	<b>T7210-1212</b>	2.32	59	3.54	90	3.74	95
25	1	1	-1616	1.1/2	38	<b>T7210-1616</b>	2.56	65	4.25	108	4.57	116
31	1.1/4	1.1/4	-2020	2	50	<b>T7210-2020</b>	4.21	107	6.22	158	1.81	46

### BSPO T7027

60° SEAT  
O RING

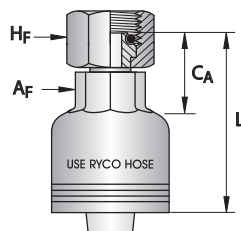

HOSE SIZE		THRD SIZE	DASH SIZE	BACK UP AF	FEMALE HEX		BSPO FEMALE					
DN	inch	inch		inch	mm	inch	mm	PART NO	CA		L	
									inch	mm	inch	mm
19	3/4	3/4	-1212	1.1/16	27	1.1/4	32	<b>T7027-1212</b>	1.30	33	2.52	64
25	1	1	-1616	1.1/4	32	1.1/2	38	<b>T7027-1616</b>	1.50	38	3.19	81

**NOTE:** T7000 BSPP, JIC, JIS and Metric Swivel Nut Couplings are shown as "Crimp Nut". Larger sizes are "Wire Nut" or "Slip Nut".

### BSPO T7057

60° SEAT  
O RING

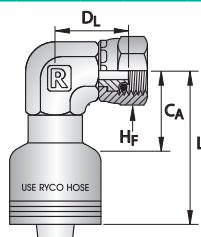

HOSE SIZE		THRD SIZE	DASH SIZE	FEMALE HEX		BSPO FEMALE 90° ELBOW						
DN	inch	inch		inch	mm	PART NO	CA		L		DL	
							inch	mm	inch	mm	inch	mm
19	3/4	3/4	-1212	1.1/4	32	<b>T7057-1212</b>	1.54	39	2.76	70	1.50	38

INTRODUCTION

HOSE

COUPLINGS

ADAPTORS

TECHNICAL

# COUPLINGS

## T7000 SERIES ONE-PIECE CRIMP COUPLINGS

<b>BSP0</b>	<b>T7277</b>
-------------	--------------

60° SEAT  
O RING

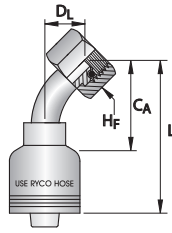

HOSE SIZE		THRD SIZE	DASH SIZE	FEMALE HEX		BSPO FEMALE 45° TUBE BEND						
DN	inch	inch		inch	mm	PART NO	CA		L		DL	
							inch	mm	inch	mm	inch	mm
12	1/2	1/2	-0808	1.1/16	27	<b>T7277-0808</b>	1.97	50	3.03	77	0.83	21
19	3/4	3/4	-1212	1.1/4	32	<b>T7277-1212</b>	2.76	70	3.98	101	1.26	32
25	1	1	-1616	1.1/2	38	<b>T7277-1616</b>	3.35	85	5.04	128	1.65	42

<b>BSP0</b>	<b>T7267</b>
-------------	--------------

60° SEAT  
O RING

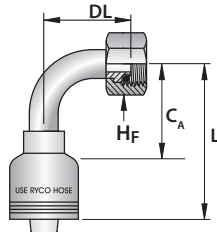

HOSE SIZE		THRD SIZE	DASH SIZE	FEMALE HEX		BSPO FEMALE 90° TUBE BEND						
DN	inch	inch		inch	mm	PART NO	CA		L		DL	
							inch	mm	inch	mm	inch	mm
12	1/2	1/2	-0808	1.1/16	27	<b>T7267-0808</b>	1.57	40	2.68	68	1.73	44
19	3/4	3/4	-1212	1.1/4	32	<b>T7267-1212</b>	2.17	55	3.39	86	2.32	59
25	1	1	-1616	1.1/2	38	<b>T7267-1616</b>	2.83	72	4.53	115	2.95	75

**NOTE:** Hose Compatibility for the **T7000** series can be found on page 272.

## T7000 SERIES ONE-PIECE CRIMP COUPLINGS

<b>NPT</b>	<b>T7090</b>	<b>T7091</b>
------------	--------------	--------------

60° SEAT

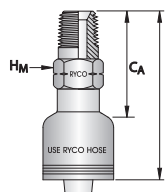
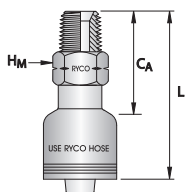

HOSE SIZE		THRD SIZE	DASH SIZE	MALE HEX	NPT MALE				NPT MALE EXTENDED (API)						
DN	inch	inch		HM-SPANNER		PART NO	CA		L		PART NO	CA		L	
				inch	mm		inch	mm	inch	mm		inch	mm	inch	mm
10	3/8	1/4	-0604	9/16		<b>T7090-0604</b>	1.38	35	2.56	65					
10	3/8	3/8	-0606	3/4	19	<b>T7090-0606</b>	1.38	35	2.56	65					
12	1/2	3/8	-0806	3/4	19	<b>T7090-0806</b>	1.50	38	2.60	66					
12	1/2	1/2	-0808	7/8	22	<b>T7090-0808</b>	1.65	42	2.72	69					
19	3/4	3/4	-1212	1.1/16	27	<b>T7090-1212</b>	1.85	47	3.07	78					
25	1	3/4	-1612	1.1/16	27	<b>T7090-1612</b>	1.85	47	3.54	90					
25	1	1	-1616	1.3/8		<b>T7090-1616</b>	2.09	53	3.78	96					
31	1.1/4	1	-2016	1.3/8		<b>T7090-2016</b>	2.28	58	4.29	109					
31	1.1/4	1.1/4	-2020	1.3/4		<b>T7090-2020</b>	2.36	60	4.37	111					
38	1.1/2	1.1/2	-2424	2		<b>T7090-2424</b>	2.17	55	4.37	111					
51	2	2	-3232	2.1/2		<b>T7090-3232</b>	2.60	66	5.08	129	<b>T7091-3232</b>	4.21	107	6.69	170

**NOTE:** Hose Compatibility for the **T7000** series can be found on page 272.



# COUPLINGS

## T7000 SERIES ONE-PIECE CRIMP COUPLINGS

<b>NPT</b>	<b>T7020N</b>
------------	---------------

60° SEAT

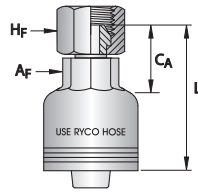

HOSE SIZE		THRD SIZE	DASH SIZE	BACK UP Af		FEMALE HEX		NPSM FEMALE					
DN	inch	inch		Af-SPANNER		Hf-SPANNER		PART NO		CA		L	
				inch	mm	inch	mm			inch	mm	inch	mm
31	1.1/4	1.1/4	-2020	1.5/8	41	2	50	<b>T7020N-2020</b>	1.77	45	3.78	96	
38	1.1/2	1.1/2	-2424	2	50	2.3/8	60	<b>T7020N-2424</b>	1.85	47	4.06	103	
51	2	2	-3232	64	2.3/4	70		<b>T7020N-3232</b>	2.13	55	4.61	117	

<b>JIC - MALE</b>	<b>T7030 - T7031</b>
-------------------	----------------------

37° FLARE

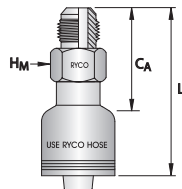

HOSE SIZE		THRD SIZE	TUBE SIZE	DASH SIZE	MALE HEX		JIC MALE					
DN	inch	inch	inch		Hm-SPANNER		PART NO		CA		L	
					inch	mm			inch	mm	inch	mm
10	3/8	9/16	3/8	-0609	5/8	16	<b>T7030-0609</b>	1.42	36	2.56	65	
12	1/2	3/4	1/2	-0812	3/4	19	<b>T7030-0812</b>	1.57	40	2.68	68	
12	1/2	7/8	5/8	-0814	15/16	24	<b>T7030-0814</b>	1.69	43	2.76	70	
16	5/8	7/8	5/8	-1014	15/16	24	<b>T7030-1014</b>	1.69	43	2.99	76	
19	3/4	1.1/16	3/4	-1217	1.1/16	27	<b>T7030-1217</b>	1.97	50	3.19	81	
19	3/4	1.3/16	7/8	-1219	1.1/4	32	<b>T7030-1219</b>	2.01	51	3.23	82	
19	3/4	1.5/16	1	-1221	1.3/8		<b>T7030-1221</b>	2.05	52	3.27	83	
						36	<b>T7031-1221</b>					
25	1	1.5/16	1	-1621	1.3/8		<b>T7030-1621</b>	2.01	51	3.70	94	
						36	<b>T7031-1621</b>					
31	1.1/4	1.5/8	1.1/4	-2026	1.3/4		<b>T7030-2026</b>	2.32	59	4.33	110	
38	1.1/2	1.7/8	1.1/2	-2430	2	50	<b>T7030-2430</b>	2.24	57	4.45	113	
51	2	2.1/2	2	-3240	2.1/2		<b>T7030-3240</b>	2.87	73	5.35	136	

**NOTE:** Hose Compatibility for the **T7000** series can be found on page 272.

## T7000 SERIES ONE-PIECE CRIMP COUPLINGS

### JSEAL™ / JIC T7040 - T7041

CONVEX SEAT

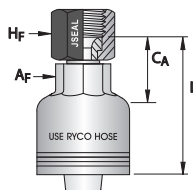

DN	HOSE SIZE		DASH SIZE	BACK UP Af		FEMALE HEX		PART NO	JSEAL™ / JIC FEMALE CA		L	
	inch	inch		inch	mm	inch	mm		inch	mm	inch	mm
10	3/8	9/16	-0609	5/8	16	11/16		<b>T7040-0609</b>	0.87	22	2.01	51
				5/8	16	3/4	19	<b>T7041-0609</b>				
10	3/8	3/4	-0612	5/8	16	7/8	22	<b>T7040-0612</b>	1.02	26	2.17	55
12	1/2	3/4	-0812	3/4	19	7/8	22	<b>T7040-0812</b>	0.94	24	2.01	51
12	1/2	7/8	-0814	3/4	19	1.1/16	27	<b>T7040-0814</b>	1.06	27	2.17	55
12	1/2	1.1/16	-0817	3/4	19	1.1/4	32	<b>T7040-0817</b>	1.22	31	2.32	59
16	5/8	3/4	-1012	15/16	24	7/8	22	<b>T7040-1012</b>	0.98	25	2.28	58
16	5/8	7/8	-1014	15/16	24	1.1/16	27	<b>T7040-1014</b>	1.06	27	2.32	59
16	5/8	1.1/16	-1017	15/16	24	1.1/4	32	<b>T7040-1017</b>	1.18	30	2.48	63
19	3/4	3/4	-1212	1.1/16	27	7/8	22	<b>T7040-1212</b>	1.18	30	2.40	61
19	3/4	7/8	-1214	1.1/16	27	1.1/16	27	<b>T7040-1214</b>	1.34	34	2.56	65
19	3/4	1.1/16	-1217	1.1/16	27	1.1/4	32	<b>T7040-1217</b>	1.22	31	2.44	62
19	3/4	1.3/16	-1219	1.1/16	27	1.3/8		<b>T7040-1219</b>	1.22	31	2.44	62
19	3/4	1.5/16	-1221	1.1/16	27	1.1/2	38	<b>T7040-1221</b>	1.50	38	2.72	69
25	1	1.1/16	-1617	1.1/4	32	1.1/4	32	<b>T7040-1617</b>	1.34	34	3.03	77
25	1	1.5/16	-1621	1.1/4	32	1.1/2	38	<b>T7040-1621</b>	1.38	35	3.07	78
25	1	1.5/8	-1626	1.1/4	32	2	50	<b>T7040-1626</b>	1.61	41	3.31	84
31	1.1/4	1.5/16	-2021	1.5/8	41	1.1/2	38	<b>T7040-2021</b>	1.69	43	3.70	94
31	1.1/4	1.5/8	-2026	1.5/8	41	2	50	<b>T7040-2026</b>	1.69	43	3.70	94
31	1.1/4	1.7/8	-2030	1.5/8	41	2.1/4	57	<b>T7040-2030</b>	2.05	52	4.06	103
38	1.1/2	1.7/8	-2430	2	50	2.1/4	57	<b>T7040-2430</b>	2.09	53	4.29	109
51	2	2.1/2	-3240		65	2.7/8	73	<b>T7040-3240</b>	2.44	62	4.88	124

### JIC - HEAVY DUTY T7045

37° FLARE

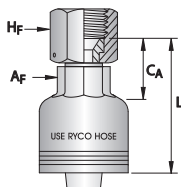

DN	HOSE SIZE		DASH SIZE	BACK UP Af		FEMALE HEX		PART NO	JIC FEMALE HIGH PRESSURE CA		L	
	inch	inch		inch	mm	inch	mm		inch	mm	inch	mm
25	1	1.5/16	-1621	1.1/4	32	1.5/8	41	<b>T7045-1621</b>	1.30	33	2.99	76
31	1.1/4	1.5/8	-2026	1.3/4		2.1/4	57	<b>T7045-2026</b>	1.57	40	3.62	92
38	1.1/2	1.7/8	-2430	2		2.1/4	57	<b>T7045-2430</b>	2.20	56	4.45	113

**NOTE:** Hose Compatibility for the **T7000** series can be found on page 272.

INTRODUCTION

HOSE

COUPLINGS

ADAPTORS

TECHNICAL

# COUPLINGS

## T7000 SERIES ONE-PIECE CRIMP COUPLINGS

JSEAL™ / JIC	T7080
--------------	-------

CONVEX SEAT

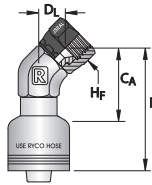

DN	HOSE SIZE	THRD SIZE	DASH SIZE	BACK UP AF		FEMALE HEX		PART NO	JSEAL™ / JIC FEMALE 45° ELBOW CA		L		DL	
				inch	mm	inch	mm		inch	mm	inch	mm	inch	mm
12	1/2	3/4	-0812	7/8	22	7/8	22	<b>T7080-0812</b>	1.14	29	2.24	57	0.63	16
12	1/2	7/8	-0814	7/8	22	1.1/16	27	<b>T7080-0814</b>	1.14	29	2.24	57	0.67	17
19	3/4	1.1/16	-1217	1.1/16	27	1.1/4	32	<b>T7080-1217</b>	1.34	34	2.52	64	0.67	17
25	1	1.5/16	-1621	1.5/16		1.1/2	38	<b>T7080-1621</b>	1.38	35	3.07	78	0.83	21

JSEAL™ / JIC	T7070	T7250 - T7251
--------------	-------	---------------

CONVEX SEAT

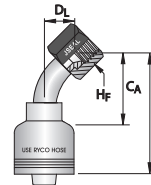
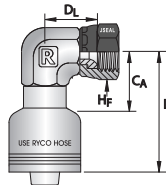

DN	HOSE SIZE	THRD SIZE	TUBE SIZE	DASH SIZE	HF-SPANNER		PART NO	JSEAL™ / JIC FEMALE 90° ELBOW CA			DL	JSEAL™ / JIC FEMALE 45° TUBE BEND CA								
					inch	mm		inch	mm	inch		mm	inch	mm	inch	mm	inch	mm		
10	3/8	9/16	3/8	-0609	11/16							<b>T7250-0609</b>	1.50	38	2.68	68	0.55	14		
					3/4	19						<b>T7251-0609</b>								
12	1/2	3/4	1/2	-0812	7/8	22						<b>T7250-0812</b>	3.03	77	4.09	104	0.83	21		
12	1/2	7/8	5/8	-0814	1.1/16	27	<b>T7070-0814</b>	1.46	37	2.56	65	1.22	31	<b>T7250-0814</b>	1.85	47	2.95	75	0.87	22
16	5/8	7/8	5/8	-1014	1.1/16	27						<b>T7250-1014</b>	2.44	62	3.70	94	0.94	24		
16	5/8	1.1/16	3/4	-1017	1.1/4	32						<b>T7250-1017</b>	2.13	54	3.43	87	0.94	24		
19	3/4	1.1/16	3/4	-1217	1.1/4	32	<b>T7070-1217</b>	1.57	40	2.80	71	1.26	32	<b>T7250-1217</b>	3.11	79	4.33	110	1.10	28
19	3/4	1.5/16	1	-1221	1.1/2	38						<b>T7250-1221</b>	3.50	89	4.72	120	1.50	38		
25	1	1.5/16	1	-1621	1.1/2	38	<b>T7070-1621</b>	1.54	39	3.23	82	1.50	38	<b>T7250-1621</b>	3.31	84	5.00	127	1.38	35
31	1.1/4	1.5/8	1.1/4	-2026	2	50						<b>T7250-2026</b>	3.94	100	5.94	151	1.54	39		
38	1.1/2	1.7/8	1.1/2	-2430	2.1/4	57						<b>T7250-2430</b>	5.04	128	7.24	184	1.97	50		
51	2	2.1/2	2	-3240	2.7/8	73						<b>T7250-3240</b>	6.46	164	8.94	227	2.48	63		

**NOTE:** Hose Compatibility for the T7000 series can be found on page 272.

## T7000 SERIES ONE-PIECE CRIMP COUPLINGS

<b>JSEAL™ / JIC</b>	<b>T7243 - T7244</b>	<b>T7240 - T7241</b>
---------------------	----------------------	----------------------

**CONVEX SEAT**

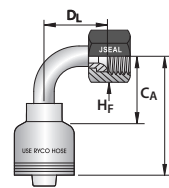
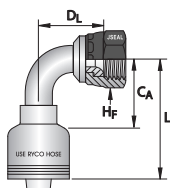

HOSE SIZE		THRD SIZE	DASH SIZE	FEMALE HEX		JSEAL™ / JIC FEMALE 90° SHORT TUBE BEND						JSEAL™ / JIC FEMALE 90° TUBE BEND							
DN	inch	inch		HF-SPANNER		PART NO	CA		L		DL		PART NO	CA		L		DL	
				inch	mm		inch	mm	inch	mm	inch	mm		inch	mm	inch	mm	inch	mm
10	3/8	9/16	-0609	11/16		<b>T7243-0609</b>	1.22	31	2.40	61	0.91	23	<b>T7240-0609</b>	1.34	34	2.52	64	1.02	26
				3/4	19	<b>T7244-0609</b>							<b>T7241-0609</b>						
10	3/8	3/4	-0612	7/8	22								<b>T7240-0612</b>	1.38	35	2.56	65	1.18	30
12	1/2	3/4	-0812	7/8	22	<b>T7243-0812</b>	1.69	43	2.80	71	1.14	29	<b>T7240-0812</b>	1.61	41	2.72	69	1.50	38
12	1/2	7/8	-0814	1.1/16	27								<b>T7240-0814</b>	1.61	41	2.72	69	1.61	41
16	5/8	7/8	-1014	1.1/16	27	<b>T7243-1014</b>	2.09	53	3.39	86	1.34	34	<b>T7240-1014</b>	1.77	45	3.07	78	1.85	47
16	5/8	1.1/16	-1017	1.1/4	32								<b>T7240-1017</b>	1.77	45	3.07	78	1.89	48
19	3/4	1.1/16	-1217	1.1/4	32	<b>T7243-1217</b>	2.60	66	3.82	97	1.85	47	<b>T7240-1217</b>	2.32	59	3.54	90	2.24	57
19	3/4	1.5/16	-1221	1.1/2	38								<b>T7240-1221</b>	2.32	59	3.54	90	2.80	71
25	1	1.5/16	-1621	1.1/2	38	<b>T7243-1621</b>	3.19	81	4.88	124	2.28	58	<b>T7240-1621</b>	2.68	68	4.37	111	2.83	72
31	1.1/4	1.5/8	-2026	2	50								<b>T7240-2026</b>	3.94	100	5.94	151	3.19	81
38	1.1/2	1.7/8	-2430	2.1/4	57								<b>T7240-2430</b>	4.17	106	6.38	162	4.17	106
51	2	2.1/2	-3240	2.7/8	73								<b>T7240-3240</b>	5.83	148	8.31	211	5.20	132

<b>JSEAL™ / JIC</b>	<b>T7245</b>
---------------------	--------------

**CONVEX SEAT**

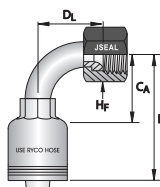

HOSE SIZE		THRD SIZE	DASH SIZE	FEMALE HEX		JSEAL™ / JIC FEMALE HIGH PRESSURE 90° TUBE BEND						
DN	inch	inch		HF-SPANNER		PART NO	CA		L		DL	
				inch	mm		inch	mm	inch	mm	inch	mm
25	1	1.5/16	-1621	1.1/2	38	<b>T7245-1621</b>	2.68	68	4.37	111	2.83	72
31	1.1/4	1.5/8	-2026	2	50	<b>T7245-2026</b>	3.46	88	5.51	140	3.07	78
38	1.1/2	1.7/8	-2430	2.1/4	57	<b>T7245-2430</b>	4.06	103	6.26	159	4.17	106

**NOTE:** Hose Compatibility for the **T7000** series can be found on page 272.

# COUPLINGS

## T7000 SERIES ONE-PIECE CRIMP COUPLINGS

JSEAL™ / JIC

T7280

CONVEX SEAT

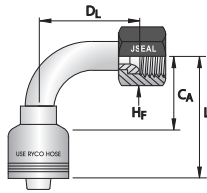

HOSE SIZE		THRD SIZE	DASH SIZE	FEMALE HEX		JSEAL™ / JIC FEMALE 90° LONG BEND						
DN	inch	inch		HF-SPANNER		PART NO	CA		L		DL	
				inch	mm		inch	mm	inch	mm	inch	mm
19	3/4	1.1/16	-1217	1.1/4	32	<b>T7280-1217</b>	2.32	59	3.54	90	3.78	96
25	1	1.5/16	-1621	1.1/2	38	<b>T7280-1621</b>	2.95	75	4.65	118	4.49	114
31	1.1/4	1.5/8	-2026	2	50	<b>T7280-2026</b>	3.94	100	5.94	151	5.08	129

JIS - BSP

T7122

60° CONCAVE SEAT

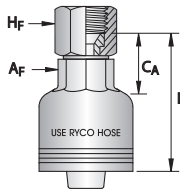

HOSE SIZE		THRD SIZE	DASH SIZE	BACK UP AF	FEMALE HEX		METRIC FEMALE 60° CONCAVE SEAT (JIS)					
DN	inch	inch	inch	AF-SPANNER		HF-SPANNER	PART NO	CA		L		
				inch	mm	inch	mm	inch	mm	inch	mm	
12	1/2	1/2	-0808	3/4	19	1.1/16	27	<b>T7122-0808</b>	0.98	25	2.09	53
16	5/8	3/4	-1012	15/16	24		36	<b>T7122-1012</b>	1.18	30	2.48	63
19	3/4	3/4	-1212	1.1/16	27		36	<b>T7122-1212</b>	1.22	31	2.44	62
25	1	1	-1616	1.1/4	32	1.5/8	41	<b>T7122-1616</b>	1.38	35	3.07	78

**NOTE:** Hose Compatibility for the **T7000** series can be found on page 272.

## T7000 SERIES ONE-PIECE CRIMP COUPLINGS

### JIS - METRIC T7680

JAPANESE INDUSTRIAL  
STANDARD  
METRIC THREAD FORM  
60° CONCAVE SEAT

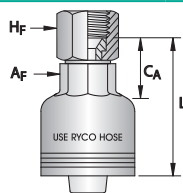

### JOINER T7900



HOSE SIZE	THRD SIZE	DASH SIZE	BACK UP Af	FEMALE HEX	METRIC FEMALE 60° CONCAVE SEAT (JIS)							
-----------	-----------	-----------	------------	------------	--------------------------------------	--	--	--	--	--	--	--

DN	inch	inch	inch	Af-SPANNER		Hf-SPANNER		PART NO	CA		L	
				inch	mm	inch	mm		inch	mm	inch	mm
10	3/8	18x1,5	-0618	5/8	16	7/8	22	<b>T7680-0618</b>	1.02	26	2.20	56
12	1/2	22x1,5	-0822	3/4	19	1.1/16	27	<b>T7680-0822</b>	1.06	27	2.17	55
12	1/2	24x1,5	-0824	3/4	19	1.3/16	30	<b>T7680-0824</b>	1.14	29	2.24	57
16	5/8	24x1,5	-1024	15/16	24	1.3/16	30	<b>T7680-1024</b>	1.18	30	2.48	63
19	3/4	24x1,5	-1224	1.1/16	27	1.3/16	30	<b>T7680-1224</b>	1.22	31	2.44	62
19	3/4	30x1,5	-1230	1.1/16	27		36	<b>T7680-1230</b>	1.50	38	2.72	69
25	1	33x1,5	-1633	1.1/4	32	1.1/2	38	<b>T7680-1633</b>	1.38	35	3.07	78
25	1	36x1,5	-1636	1.1/4	32		46	<b>T7680-1636</b>	1.38	35	3.07	78
31	1.1/4	36x1,5	-2036	1.5/8	41		46	<b>T7680-2036</b>	1.50	38	3.50	89
31	1.1/4	42x1,5	-2042	1.5/8	41	2	50	<b>T7680-2042</b>	1.69	43	3.70	94
38	1.1/2	42x1,5	-2442	2	50	2	50	<b>T7680-2442</b>	1.77	45	3.98	101

HOSE SIZE	DASH SIZE	JOINER							
-----------	-----------	--------	--	--	--	--	--	--	--

DN	inch	inch	PART NO	CA		L	
				inch	mm	inch	mm
10	3/8	-0606	<b>T7900-0606</b>	1.10	28	2.28	58
12	1/2	-0808	<b>T7900-0808</b>	1.18	30	2.24	57
19	3/4	-1212	<b>T7900-1212</b>	1.26	32	2.48	63
25	1	-1616	<b>T7900-1616</b>	1.26	32	2.95	75
31	1.1/4	-2020	<b>T7900-2020</b>	1.57	40	3.58	91
38	1.1/2	-2424	<b>T7900-2424</b>	0.98	25	3.23	82
51	2	-3232	<b>T7900-3232</b>	1.02	26	3.50	89

### METRIC - DKOL T7501 T7510

DKOL  
METRIC O RING (LIGHT)  
24° CONE

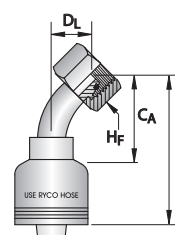
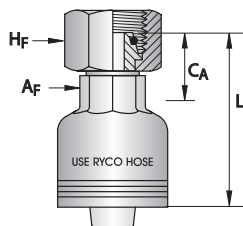

HOSE SIZE	THRD SIZE	TUBE SIZE	DASH SIZE	BACK UP Af	FEMALE HEX	METRIC DKOL FEMALE 24° CONE							METRIC DKOL FEMALE 45° TUBE BEND				
-----------	-----------	-----------	-----------	------------	------------	-----------------------------	--	--	--	--	--	--	----------------------------------	--	--	--	--

DN	inch	mm	mm	inch	mm	Af-SPANNER		PART NO	CA		L		PART NO	CA		L		DL		
						inch	mm		inch	mm	inch	mm		inch	mm	inch	mm			
19	3/4	30x2,0	22	-1230	1.1/16	27		36	<b>T7501-1230</b>	1.50	38	2.72	69							
25	1	36x2,0	28	-1636	1.1/4	32	1.5/8	41	<b>T7501-1636</b>	1.69	43	3.39	86							
31	1.1/4	45x2,0	35	-2045	1.5/8	41	2	50	<b>T7501-2045</b>	1.85	47	3.86	98							
38	1.1/2	52x2,0	42	-2452	2	50	2.3/8	60	<b>T7501-2452</b>	1.97	50	4.17	106	<b>T7510-2452</b>	4.65	118	6.85	174	1.93	49

INTRODUCTION

HOSE

COUPLINGS

ADAPTORS

TECHNICAL



# COUPLINGS

## T7000 SERIES ONE-PIECE CRIMP COUPLINGS

### METRIC - DKOL

### T7250

DKOL  
METRIC O RING (LIGHT)  
24° CONE

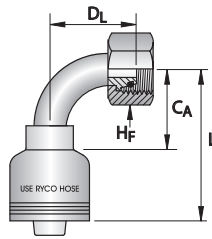

					METRIC DKOL FEMALE 24° CONE 90° TUBE BEND								
HOSE SIZE	THRD SIZE	TUBE SIZE	DASH SIZE	FEMALE HEX	HF-SPANNER		PART NO	CA		L		DL	
DN	inch	mm	mm		inch	mm		inch	mm	inch	mm	inch	mm
38	1.1/2	52	42	-2452	2.3/8	60	<b>T7520-2452</b>	4.17	106	6.38	162	4.02	102

### METRIC - DKS

### T7630

DKS MALE (HEAVY)  
24° CONE

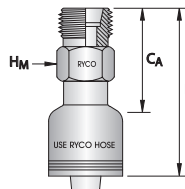

					DKS MALE 24° CONE								
HOSE SIZE	THRD SIZE	TUBE SIZE	DASH SIZE	MALE HEX	HM-SPANNER		PART NO	CA		L			
DN	inch	mm	mm		inch	mm		inch	mm	inch	mm		
12	1/2	24x1,5	16	-0824	1.1/16	27	<b>T7630-0824</b>	1.50	38	2.60	66		
19	3/4	30x2,0	20	-1230	1.1/4	32	<b>T7630-1230</b>	1.73	44	2.95	75		
19	3/4	36x2,0	25	-1236	1.5/8	41	<b>T7630-1236</b>	1.89	48	3.11	79		
25	1	36x2,0	25	-1636	1.5/8	41	<b>T7630-1636</b>	1.89	48	3.58	91		
25	1	42x2,0	30	-1642		46	<b>T7630-1642</b>	2.01	51	3.70	94		
31	1.1/4	42x2,0	30	-2042		46	<b>T7630-2042</b>	2.17	55	4.17	106		
31	1.1/4	52x2,0	38	-2052	2.3/16	55	<b>T7630-2052</b>	2.32	59	4.33	110		

**NOTE:** Hose Compatibility for the **T7000** series can be found on page 272.

## T7000 SERIES ONE-PIECE CRIMP COUPLINGS

### METRIC - DKOS T7711

**DKOS  
METRIC O RING (HEAVY)  
24° CONE**

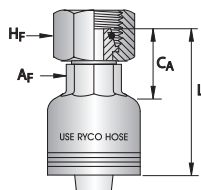

DN	HOSE SIZE	THRD SIZE	TUBE SIZE	DASH SIZE	BACK UP AF		FEMALE HEX		PART NO	DKOS FEMALE 24° CONE		L	
					inch	mm	inch	mm		inch	mm		inch
10	3/8	18x1,5	10	-0618	5/8	16	7/8	22	<b>T7711-0618</b>	1.22	31	2.36	60
10	3/8	20x1,5	12	-0620	5/8	16	15/16	24	<b>T7711-0620</b>	1.22	31	2.40	61
10	3/8	22x1,5	14	-0622	5/8	16	1.1/16	27	<b>T7711-0622</b>	1.30	33	2.48	63
12	1/2	24x1,5	16	-0824	3/4	19	1.3/16	30	<b>T7711-0824</b>	1.30	33	2.40	61
16	5/8	30x2,0	20	-1030	15/16	24		36	<b>T7711-1030</b>	1.57	40	2.83	72
16	5/8	36x2,0	25	-1036	15/16	24	1.5/8	41	<b>T7711-1036</b>	1.73	44	2.99	76
19	3/4	30x2,0	20	-1230	1.1/16	27		36	<b>T7711-1230</b>	1.65	42	2.87	73
19	3/4	36x2,0	25	-1236	1.1/16	27		46	<b>T7711-1236</b>	1.81	46	3.03	77
19	3/4	42x2,0	30	-1242	1.1/16	27	2	50	<b>T7711-1242</b>	1.85	47	3.07	78
25	1	30x2,0	20	-1630	1.1/4	32		36	<b>T7711-1630</b>	1.65	42	3.35	85
25	1	36x2,0	25	-1636	1.1/4	32		46	<b>T7711-1636</b>	1.81	46	3.50	89
25	1	42x2,0	30	-1642	1.1/4	32	2	50	<b>T7711-1642</b>	1.81	46	3.50	89
31	1.1/4	42x2,0	30	-2042	1.5/8	41	2	50	<b>T7711-2042</b>	2.01	51	4.02	102
31	1.1/4	52x2,0	38	-2052	1.5/8	41	2.3/8	60	<b>T7711-2052</b>	2.24	57	4.25	108
38	1.1/2	52x2,0	38	-2452	2	50	2.3/8	60	<b>T7711-2452</b>	2.28	58	4.53	115

### METRIC - DKOS T7720 T7730

**DKOS  
METRIC O RING (HEAVY)  
24° CONE**

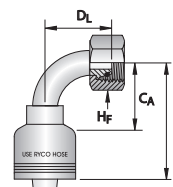
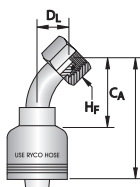

DN	HOSE SIZE	THRD SIZE	TUBE SIZE	DASH SIZE	FEMALE HEX		DKOS FEMALE 24° CONE 45° TUBE BEND					DKOS FEMALE 24° CONE 90° TUBE BEND								
					inch	mm	inch	mm	CA	L	DL	PART NO	CA	L	DL	PART NO	CA	L	DL	
10	3/8	18x1,5	10	-0618	7/8	22							<b>T7730-0618</b>	1.06	27	2.24	57	1.18	30	
12	1/2	24x1,5	16	-0824	1.3/16	30	<b>T7720-0824</b>	2.09	53	3.19	81	0.94	24	<b>T7730-0824</b>	1.61	41	2.72	69	1.89	48
16	5/8	24x1,5	16	-1024	1.3/16	30							<b>T7730-1024</b>	1.77	45	3.07	78	1.89	48	
19	3/4	30x2,0	20	-1230		36	<b>T7720-1230</b>	2.91	74	4.13	105	1.38	35	<b>T7730-1230</b>	2.32	59	3.54	90	2.68	68
19	3/4	36x2,0	25	-1236		46	<b>T7720-1236</b>	2.99	76	4.21	107	1.38	35	<b>T7730-1236</b>	2.32	59	3.54	90	2.68	68
25	1	42x2,0	30	-1642	2	50	<b>T7720-1642</b>	3.43	87	5.12	130	1.46	37	<b>T7730-1642</b>	2.72	69	4.41	112	3.03	77
31	1.1/4	42x2,0	30	-2042	2	50							<b>T7730-2042</b>	2.76	70	4.76	121	3.03	77	
31	1.1/4	52x2,0	38	-2052	2.3/8	60							<b>T7730-2052</b>	3.94	100	5.94	151	3.50	89	
38	1.1/2	52x2,0	38	-2452	2.3/8	60							<b>T7730-2452</b>	3.58	91	5.79	147	3.50	89	
31	1.1/4	52x2,0	38	-2052	2.3/8	60	<b>T7720-2052</b>	4.17	106	6.18	157	1.89	48							

**NOTE:** Hose Compatibility for the **T7000** series can be found on page 272.

INTRODUCTION

HOSE

COUPLINGS

ADAPTORS

TECHNICAL

# COUPLINGS

## T7000 SERIES ONE-PIECE CRIMP COUPLINGS

ORFS	T7840
------	-------

O RING  
FACE SEAL

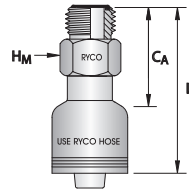

DN	HOSE SIZE	THRD SIZE	TUBE SIZE	DASH SIZE	HM-SPANNER		PART NO	CA		L	
					inch	mm		inch	mm	inch	mm
10	3/8	11/16	3/8	-0611	3/4	19	<b>T7840-0611</b>	1.34	34	2.52	64
12	1/2	13/16	1/2	-0813	7/8	22	<b>T7840-0813</b>	1.50	38	2.56	65
19	3/4	1.3/16	3/4	-1219	1.1/4	32	<b>T7840-1219</b>	1.85	47	3.07	78
25	1	1.7/16	1	-1623	1.1/2	38	<b>T7840-1623</b>	2.01	51	3.70	94
31	1.1/4	1.11/16	1.1/4	-2027	2	50	<b>T7840-2027</b>	2.28	58	4.29	109

ORFS	T7800 - T7801
------	---------------

O RING  
FACE SEAL

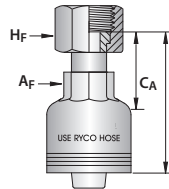

DN	HOSE SIZE	THRD SIZE	DASH SIZE	AF-SPANNER		HF-SPANNER		PART NO	CA		L	
				inch	mm	inch	mm		inch	mm	inch	mm
10	3/8	11/16	-0611	5/8	16	7/8	22	<b>T7800-0611</b>	1.26	32	2.44	62
				5/8	16	7/8	22	<b>T7801-0611</b>				
10	3/8	13/16	-0613	5/8	16	15/16	24	<b>T7800-0613</b>	1.38	35	2.56	65
12	1/2	13/16	-0813	3/4	19	15/16	24	<b>T7800-0813</b>	1.42	36	2.52	64
				3/4	19	1.1/8		<b>T7800-0816</b>				
12	1/2	1	-0816	3/4	19	1.3/16	30	<b>T7801-0816</b>	1.50	38	2.60	66
				3/4	19	1.3/8		<b>T7800-0819</b>				
12	1/2	1.3/16	-0819	3/4	19		36	<b>T7801-0819</b>	1.65	42	2.72	69
				3/4	19			<b>T7800-1016</b>				
16	5/8	1	-1016	15/16	24	1.1/8		<b>T7800-1016</b>	1.38	35	2.64	67
				15/16	24	1.3/16	30	<b>T7801-1016</b>				
19	3/4	1	-1216	1.1/16	27	1.1/8		<b>T7800-1216</b>	1.54	39	2.76	70
				1.1/16	27	1.3/16	30	<b>T7801-1216</b>				
19	3/4	1.3/16	-1219	1.1/16	27	1.3/8		<b>T7800-1219</b>	1.65	42	2.87	73
				1.1/16	27		36	<b>T7801-1219</b>				
19	3/4	1.7/16	-1223	1.1/16	27	1.5/8	41	<b>T7800-1223</b>	1.65	42	2.87	73
25	1	1.7/16	-1623	1.1/4	32	1.5/8	41	<b>T7800-1623</b>	1.61	41	3.31	84
25	1	1.11/16	-1627	1.1/4	32	2	50	<b>T7800-1627</b>	1.73	44	3.43	87
31	1.1/4	1.7/16	-2023	1.5/8	41	1.5/8	41	<b>T7800-2023</b>	2.13	54	4.13	105
31	1.1/4	1.11/16	-2027	1.5/8	41	2	50	<b>T7800-2027</b>	1.89	48	3.90	99
38	1.1/2	2	-2432	2	50	2.1/4	57	<b>T7800-2432</b>	2.32	59	4.53	115

**NOTE:** Hose Compatibility for the T7000 series can be found on page 272.

## T7000 SERIES ONE-PIECE CRIMP COUPLINGS

<b>ORFS</b>	<b>T7810 - T7811</b>	<b>T7823 - T7824</b>
-------------	----------------------	----------------------

**O RING  
FACE SEAL**

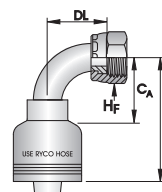
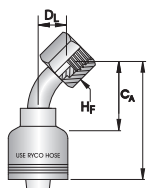

HOSE SIZE			THRD SIZE	DASH SIZE	FEMALE HEX	ORFS FEMALE 45° TUBE BEND						ORFS FEMALE 90° SHORT BEND							
DN	inch	inch		HF-SPANNER	PART NO	CA		L		DL		PART NO	CA		L		DL		
				inch	mm	inch	mm	inch	mm	inch	mm		inch	mm	inch	mm	inch	mm	
10	3/8	11/16	-0611	7/8	22	<b>T7810-0611</b>	1.77	45	2.91	74	0.79	20							
10	3/8	13/16	-0613	15/16	24	<b>T7810-0613</b>	1.57	40	2.76	70	0.67	17							
12	1/2	13/16	-0813	15/16	24	<b>T7810-0813</b>	1.93	49	2.99	76	0.75	19							
12	1/2	1	-0816	1.1/8		<b>T7810-0816</b>	1.89	48	2.99	76	0.75	19							
				1.3/16	30	<b>T7811-0816</b>													
16	5/8	1	-1016	1.1/8		<b>T7810-1016</b>	2.32	59	3.62	92	0.79	20							
				1.3/16	30	<b>T7811-1016</b>													
19	3/4	1.3/16	-1219	1.3/8		<b>T7810-1219</b>	3.11	79	4.33	110	1.14	29	<b>T7823-1219</b>	2.32	59	3.54	90	1.89	48
					36	<b>T7810-1219</b>							<b>T7824-1219</b>						
19	3/4	1.7/16	-1223	1.5/8	41	<b>T7810-1223</b>	3.03	77	4.25	108	1.02	26							
25	1	1.7/16	-1623	1.5/8	41	<b>T7810-1623</b>	3.39	86	5.08	129	1.34	34	<b>T7823-1623</b>	3.19	81	4.88	124	2.20	56
25	1	1.11/16	-1627	2	50	<b>T7810-1627</b>	3.39	86	5.08	129	1.26	32							
31	1.1/4	1.11/16	-2027	2	50	<b>T7810-2027</b>	4.02	102	6.02	153	1.77	45	<b>T7823-2027</b>	3.94	100	5.94	151	2.52	64
38	1.1/2	2	-2432	2.1/4	57	<b>T7810-2432</b>	5.16	131	7.36	187	2.09	53							

<b>ORFS</b>	<b>T7820 - T7821</b>	<b>T7830 - T7831</b>
-------------	----------------------	----------------------

**O RING  
FACE SEAL**

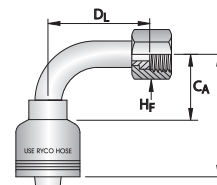
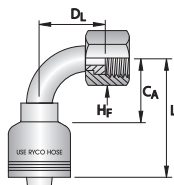

HOSE SIZE			THRD SIZE	DASH SIZE	FEMALE HEX	ORFS FEMALE 90° MEDIUM BEND						ORFS FEMALE 90° LONG BEND							
DN	inch	inch		HF-SPANNER	PART NO	CA		L		DL		PART NO	CA		L		DL		
				inch	mm	inch	mm	inch	mm	inch	mm		inch	mm	inch	mm	inch	mm	
10	3/8	11/16	-0611	7/8	22	<b>T7820-0611</b>	1.38	35	2.56	65	1.50	38	<b>T7830-0611</b>	1.38	35	2.56	65	2.17	55
10	3/8	13/16	-0613	15/16	24	<b>T7820-0613</b>	1.50	38	2.68	68	1.34	34							
12	1/2	13/16	-0813	15/16	24	<b>T7820-0813</b>	1.61	41	2.72	69	1.61	41	<b>T7830-0813</b>	1.69	43	2.80	71	2.56	65
12	1/2	1	-0816	1.1/8		<b>T7820-0816</b>	1.61	41	2.72	69	1.85	47							
				1.3/16	30	<b>T7821-0816</b>													
12	1/2	1.3/16	-0819	1.3/8		<b>T7820-0819</b>	1.61	41	2.72	69	2.28	58							
					36	<b>T7821-0819</b>													
16	5/8	1	-1016	1.1/8		<b>T7820-1016</b>	1.77	45	3.07	78	1.85	47							
				1.3/16	30	<b>T7821-1016</b>													
19	3/4	1	-1216	1.1/8		<b>T7820-1216</b>	2.17	55	3.39	86	1.85	47							
				1.3/16	30	<b>T7821-1216</b>													
19	3/4	1.3/16	-1219	1.3/8		<b>T7820-1219</b>	2.32	59	3.54	90	2.32	59	<b>T7830-1219</b>	2.32	59	3.54	90	3.78	96
					36	<b>T7821-1219</b>							<b>T7831-1219</b>						
19	3/4	1.7/16	-1223	1.5/8	41	<b>T7820-1223</b>	2.32	59	3.54	90	2.09	53							
25	1	1.7/16	-1623	1.5/8	41	<b>T7820-1623</b>	2.72	69	4.41	112	2.80	71	<b>T7830-1623</b>	2.91	74	4.61	117	4.45	113
31	1.1/4	1.11/16	-2027	2	50	<b>T7820-2027</b>	3.94	100	5.94	151	3.54	90	<b>T7830-2027</b>	3.94	100	5.94	151	5.08	129
38	1.1/2	2	-2432	2.1/4	57	<b>T7820-2432</b>	4.17	106	6.38	162	4.21	107							

INTRODUCTION

HOSE

COUPLINGS

ADAPTORS

TECHNICAL

# COUPLINGS

## T7000 SERIES ONE-PIECE CRIMP COUPLINGS

<b>RYCOLOK</b>	<b>T7870</b>	<b>T7871</b>
----------------	--------------	--------------

STAPLE  
O RING & BACK UP  
RING SUPPLIED

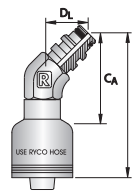
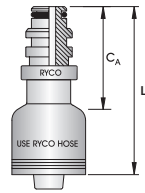

HOSE SIZE		STAPLE SIZE	DASH SIZE	RYCOLOK MALE				RYCOLOK MALE 45° ELBOW									
DN	inch	mm		PART NO		CA		L		PART NO		CA		L		DL	
				inch	mm	inch	mm	inch	mm	inch	mm	inch	mm	inch	mm	inch	mm
10	3/8	10	-0610	<b>T7870-0610</b>	1.81	46	2.99	76		<b>T7871-0610</b>	2.09	53	3.07	78	1.06	27	
12	1/2	12	-0812	<b>T7870-0812</b>	1.93	49	2.99	76		<b>T7871-0812</b>	2.17	55	3.27	83	1.10	28	
16	5/8	16	-1016	<b>T7870-1016</b>	1.73	44	3.03	77									
19	3/4	20	-1220	<b>T7870-1220</b>	1.89	48	3.11	79		<b>T7871-1220</b>	2.60	66	3.82	97	1.30	33	
25	1	25	-1625	<b>T7870-1625</b>	2.28	58	3.98	101		<b>T7871-1625</b>	2.76	70	4.45	113	1.46	37	
31	1.1/4	32	-2032	<b>T7870-2032</b>	2.32	59	4.33	110		<b>T7871-2032</b>	2.95	75	4.96	126	1.46	37	
38	1.1/2	40	-2440	<b>T7870-2440</b>	2.36	60	4.57	116		<b>T7871-2440</b>	3.23	82	5.43	138	1.73	44	
51	2	50	-3250	<b>T7870-3250</b>	2.28	58	4.72	120		<b>T7871-3250</b>	3.43	87	5.91	150	1.81	46	
63	2.1/2	63	-4063	<b>T7870-4063</b>	3.54	90	6.57	167									

<b>RYCOLOK</b>	<b>T7872</b>
----------------	--------------

STAPLE  
O RING & BACK UP  
RING SUPPLIED

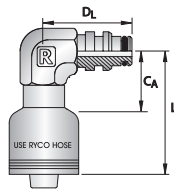

HOSE SIZE		STAPLE SIZE	DASH SIZE	RYCOLOK MALE 90° ELBOW							
DN	inch	mm		PART NO		CA		L		DL	
				inch	mm	inch	mm	inch	mm	inch	mm
10	3/8	10	-0610	<b>T7872-0610</b>	1.22	31	2.36	60	1.81	46	
12	1/2	12	-0812	<b>T7872-0812</b>	1.54	39	2.64	67	1.97	50	
16	5/8	16	-1016	<b>T7872-1016</b>	2.76	70	4.06	103	2.05	52	
19	3/4	20	-1220	<b>T7872-1220</b>	1.73	44	2.95	75	2.20	56	
25	1	25	-1625	<b>T7872-1625</b>	2.05	52	3.74	95	2.68	68	
31	1.1/4	32	-2032	<b>T7872-2032</b>	2.36	60	4.37	111	2.68	68	
38	1.1/2	40	-2440	<b>T7872-2440</b>	2.40	61	4.61	117	3.35	85	

<b>SUPERLOK</b>	<b>T7876</b>
-----------------	--------------

SUPERSTAPLE  
O RING & BACK UP  
RING SUPPLIED

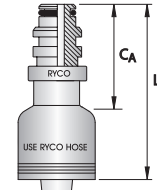

HOSE SIZE		STAPLE SIZE	DASH SIZE	SUPERLOK MALE					
DN	inch	mm		PART NO		CA		L	
				inch	mm	inch	mm	inch	mm
12	1/2	12	-0812	<b>T7876-0812</b>	2.09	53	3.19	81	
19	3/4	20	-1220	<b>T7876-1220</b>	2.24	57	3.46	88	
25	1	25	-1625	<b>T7876-1625</b>	2.95	75	4.65	118	
31	1.1/4	32	-2032	<b>T7876-2032</b>	3.15	80	5.16	131	
38	1.1/2	40	-2440	<b>T7876-2440</b>	3.07	78	5.31	135	
51	2	50	-3250	<b>T7876-3250</b>	3.11	79	5.55	141	

**NOTE:** Hose Compatibility for the **T7000** series can be found on page 272.

## T7000 SERIES ONE-PIECE CRIMP COUPLINGS

<b>RYCO WEO</b>	<b>T7480</b>	<b>T7482</b>
-----------------	--------------	--------------

WEO

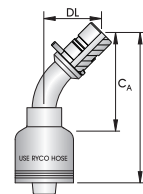
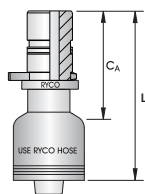

HOSE SIZE		PLUG-IN SIZE		MAX WORKING PRESSURE		RYCO WEO MALE						RYCO WEO MALE 45° TUBE BEND						
DN	dash	inch	DN	inch	bar	psi	PART NO	CA		L		PART NO	CA		L		DL	
								inch	mm	inch	mm		inch	mm	inch	mm	inch	mm
10	-06	3/8	10	3/8	350	5100	<b>T7480-0606</b>	1.69	43	2.83	72	<b>T7482-0606</b>	2.17	55	3.35	85	1.06	27
12	-08	1/2	12	1/2	350	5100	<b>T7480-0808</b>	1.73	44	2.80	71	<b>T7482-0808</b>	2.32	59	3.43	87	1.22	31
16	-12	5/8	16	3/4	350	5100	<b>T7480-1012</b>	1.97	50	3.27	83	<b>T7482-1012</b>	2.83	72	4.13	105	1.57	40
19	-12	3/4	19	3/4	350	5100	<b>T7480-1212</b>	2.13	54	3.35	85	<b>T7482-1212</b>	3.23	82	4.45	113	1.69	43
25	-16	1	25	1	250	3600	<b>T7480-1616</b>	2.52	64	4.21	107	<b>T7482-1616</b>	4.13	105	5.83	148	2.09	53

**NOTE:** RYCO WEO male and female couplings and adaptors do not contain a shut-off valve. When not in use, cap the RYCO WEO male using the appropriate size RW811 series stop cap and plug the RYCO WEO female/cartridge using the appropriate size RW723 series stop plug.

<b>RYCO WEO</b>	<b>T7483</b>
-----------------	--------------

WEO

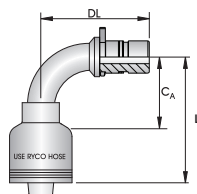

HOSE SIZE		PLUG-IN SIZE		MAX WORKING PRESSURE		RYCO WEO MALE 90° TUBE BEND							
DN	dash	inch	DN	inch	mm	bar	PART NO	CA		L		DL	
								inch	mm	inch	mm	inch	mm
10	-06	3/8	10	3/8	350	5100	<b>T7483-0606</b>	1.38	35	2.56	65	2.05	52
12	-08	1/2	12	1/2	350	5100	<b>T7483-0808</b>	1.50	38	2.60	66	2.28	58
16	-12	3/4	19	3/4	350	5100	<b>T7483-1012</b>	1.89	48	3.19	81	2.80	71
19	-12	3/4	19	3/4	350	5100	<b>T7483-1212</b>	2.32	59	3.54	90	3.23	82
25	-16	1	25	1	250	3600	<b>T7483-1616</b>	2.83	72	4.53	115	3.94	100

**NOTE:** RYCO WEO male and female couplings and adaptors do not contain a shut-off valve. When not in use, cap the RYCO WEO male using the appropriate size RW811 series stop cap and plug the RYCO WEO female/cartridge using the appropriate size RW723 series stop plug.

**NOTE:** Hose Compatibility for the **T7000** series can be found on page 272.

INTRODUCTION

HOSE

COUPLINGS

ADAPTORS

TECHNICAL



# COUPLINGS

## T7000 SERIES ONE-PIECE CRIMP COUPLINGS

### DIMENSIONS FOR SAE CODE 61 AND CODE 62 FLANGES, AND RYCO CODE 62C FLANGES

NOMINAL FLANGE	CODE 61				CODE 62				CODE 62C				
	B		T		B		T		B		T		
inch	mm	inch	mm	inch	mm	inch	mm	inch	mm	inch	mm	inch	mm
1/2	30,2	1.19	6,73	0.265	31,8	1.25	7,75	0.305					
5/8	34,0	1.34	6,73	0.265									
3/4	38,1	1.50	6,73	0.265	41,3	1.63	8,76	0.345	41,3	1.63	14,20	0.559	
1	44,5	1.75	8,00	0.315	47,6	1.88	9,53	0.375	47,6	1.88	14,20	0.559	
1.1/4	50,8	2.00	8,00	0.315	54,0	2.12	10,29	0.405	54,0	2.12	14,20	0.559	
1.1/2	60,3	2.38	8,00	0.315	63,5	2.50	12,57	0.495	63,5	2.50	14,20	0.559	
2	71,4	2.81	9,53	0.375	79,4	3.13	12,57	0.495	79,4	3.13	14,20	0.559	
2.1/2	84,1	3.31	9,53	0.375									
3	101,6	4.00	9,53	0.375									

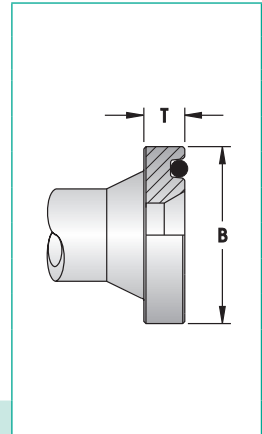

**NOTE:** RYCO Code 62C fittings conform to the flange OD and bolt hole patterns of SAE Code 62 but require special flange clamps. RYCO Code 62C flange heads are thicker than SAE Code 62 and measure T = 14,2 mm (0.559 inch) in all sizes.

SAE FLANGE	T7130	T7140
------------	-------	-------

**RYCO CODE 61 CLAMPS - SEE PAGES 440 & 441**  
O RING NOT SUPPLIED

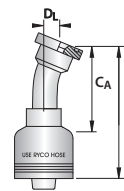
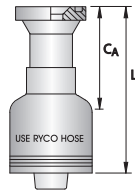

HOSE SIZE	NOM. FLANGE SIZE	DASH SIZE	CODE 61 FLANGE						CODE 61 FLANGE 22.5° TUBE BEND						
			PART NO		CA		L		PART NO		CA		L		DL
DN	inch	inch		inch	mm	inch	mm	inch	mm	inch	mm	inch	mm	inch	mm
12	1/2	1/2	-0808	<b>T7130-0808</b>	1.77	45	2.83	72							
12	1/2	3/4	-0812	<b>T7130-0812</b>	1.89	48	2.95	75							
19	3/4	5/8	-1210	<b>T7130-1210</b>	1.77	45	2.99	76							
19	3/4	3/4	-1212	<b>T7130-1212</b>	1.81	46	3.03	77	<b>T7140-1212</b>	2.83	72	4.06	103	0.47	12
19	3/4	1	-1216	<b>T7130-1216</b>	1.97	50	3.19	81	<b>T7140-1216</b>	2.95	75	4.17	106	0.59	15
19	3/4	1.1/4	-1220	<b>T7130-1220</b>	2.24	57	3.46	88							
25	1	1	-1616	<b>T7130-1616</b>	2.05	52	3.74	95	<b>T7140-1616</b>	3.43	87	5.12	130	0.55	14
25	1	1.1/4	-1620	<b>T7130-1620</b>	2.24	57	3.94	100	<b>T7140-1620</b>	3.43	87	5.12	130	0.51	13
25	1	1.1/2	-1624	<b>T7130-1624</b>	3.31	84	5.00	127							
31	1.1/4	1	-2016	<b>T7130-2016</b>	2.13	54	4.13	105							
31	1.1/4	1.1/4	-2020	<b>T7130-2020</b>	2.32	59	4.33	110	<b>T7140-2020</b>	4.17	106	6.18	157	0.63	16
31	1.1/4	1.1/2	-2024	<b>T7130-2024</b>	3.35	85	5.35	136	<b>T7140-2024</b>	4.29	109	6.30	160	0.79	20
38	1.1/2	1.1/4	-2420	<b>T7130-2420</b>	2.36	60	4.57	116							
38	1.1/2	1.1/2	-2424	<b>T7130-2424</b>	3.35	85	5.59	142	<b>T7140-2424</b>	4.65	118	6.85	174	0.94	24
38	1.1/2	2	-2432	<b>T7130-2432</b>	3.74	95	5.98	152	<b>T7140-2432</b>	5.28	134	7.48	190	1.06	27
51	2	2	-3232	<b>T7130-3232</b>	3.78	96	6.22	158	<b>T7140-3232</b>	6.38	162	8.86	225	0.98	25
51	2	2.1/2	-3240	<b>T7130-3240</b>	3.98	101	6.42	163							
63	2.1/2	2.1/2	-4040	<b>T7130-4040</b>	3.11	79	6.14	156							

**NOTE:** Hose Compatibility for the **T7000** series can be found on page 272.

## T7000 SERIES ONE-PIECE CRIMP COUPLINGS

SAE FLANGE	T7150	T7300
------------	-------	-------

RYCO  
CODE 61  
CLAMPS - SEE PAGES  
440 & 441  
O RING NOT SUPPLIED

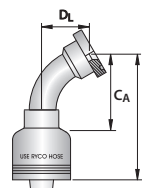
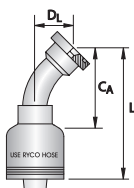

HOSE SIZE	DN	NOM. FLANGE SIZE	DASH SIZE	CODE 61 FLANGE 45° TUBE BEND							CODE 61 FLANGE 60° TUBE BEND							
				PART NO	CA		L		DL		PART NO	CA		L		DL		
	inch	inch			inch	mm	inch	mm	inch	mm		inch	mm	inch	mm	inch	mm	
	12	1/2	1/2	-0808	<b>T7150-0808</b>	1.93	49	3.03	77	0.79	20							
	12	1/2	3/4	-0812	<b>T7150-0812</b>	2.01	51	3.07	78	0.94	24							
	19	3/4	5/8	-1210	<b>T7150-1210</b>	2.32	59	3.54	90	1.02	26							
	19	3/4	3/4	-1212	<b>T7150-1212</b>	2.56	65	3.78	96	1.02	26	<b>T7300-1212</b>	3.07	78	4.29	109	1.46	37
	19	3/4	1	-1216	<b>T7150-1216</b>	2.68	68	3.90	99	1.18	30	<b>T7300-1216</b>	3.15	80	4.37	111	1.61	41
	25	1	1	-1616	<b>T7150-1616</b>	3.19	81	4.88	124	1.18	30	<b>T7300-1616</b>	3.74	95	5.43	138	1.77	45
	25	1	1.1/4	-1620	<b>T7150-1620</b>	3.27	83	4.96	126	1.26	32	<b>T7300-1620</b>	3.82	97	5.51	140	1.77	45
	31	1.1/4	1	-2016	<b>T7150-2016</b>	3.46	88	5.47	139	1.18	30							
	31	1.1/4	1.1/4	-2020	<b>T7150-2020</b>	3.94	100	5.94	151	1.42	36	<b>T7300-2020</b>	4.45	113	6.50	165	2.01	51
	31	1.1/4	1.1/2	-2024	<b>T7150-2024</b>	4.06	103	6.06	154	1.57	40	<b>T7300-2024</b>	4.76	121	6.81	173	2.13	54
	38	1.1/2	1.1/2	-2424	<b>T7150-2424</b>	4.33	110	6.54	166	1.65	42	<b>T7300-2424</b>	5.67	144	7.87	200	2.36	60
	38	1.1/2	2	-2432	<b>T7150-2432</b>	4.72	120	6.93	176	1.85	47	<b>T7300-2432</b>	5.79	147	7.99	203	2.68	68
	51	2	2	-3232	<b>T7150-3232</b>	5.91	150	8.39	213	2.28	58	<b>T7300-3232</b>	6.65	169	9.13	232	3.66	93

**NOTE:** Hose Compatibility for the **T7000** series can be found on page 272.

INTRODUCTION

HOSE

COUPLINGS

ADAPTORS

TECHNICAL

# COUPLINGS

## T7000 SERIES ONE-PIECE CRIMP COUPLINGS

SAE FLANGE	T7290	T7160
------------	-------	-------

RYCO  
CODE 61  
CLAMPS - SEE PAGES  
440 & 441  
O RING NOT SUPPLIED

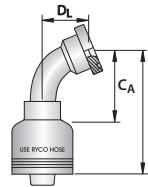
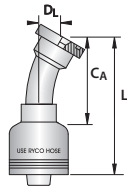

HOSE SIZE	DN	NOM. FLANGE SIZE	DASH SIZE	CODE 61 FLANGE 30° TUBE BEND							CODE 61 FLANGE 67.5° TUBE BEND							
				PART NO	CA		L		DL		PART NO	CA		L		DL		
	inch	inch		inch	mm	inch	mm	inch	mm	inch	mm	inch	mm	inch	mm			
	19	3/4	3/4	-1212	<b>T7290-1212</b>	2.76	70	3.98	101	0.71	18	<b>T7160-1212</b>	2.83	72	4.06	103	1.77	45
	19	3/4	1	-1216								<b>T7160-1216</b>	2.87	73	4.09	104	1.93	49
	25	1	1	-1616	<b>T7290-1616</b>	3.35	85	5.04	128	0.71	18	<b>T7160-1616</b>	3.46	88	5.16	131	1.93	49
	25	1	1.1/4	-1620								<b>T7160-1620</b>	3.46	88	5.16	131	2.05	52
	31	1.1/4	1.1/4	-2020	<b>T7290-2020</b>	4.09	104	6.14	156	0.79	20	<b>T7160-2020</b>	3.98	101	5.98	152	2.64	67
	31	1.1/4	1.1/2	-2024	<b>T7290-2024</b>	4.37	111	6.38	162	0.94	24	<b>T7160-2024</b>	4.29	109	6.30	160	2.52	64
	38	1.1/2	1.1/2	-2424	<b>T7290-2424</b>	4.65	118	6.85	174	1.02	26	<b>T7160-2424</b>	5.28	134	7.48	190	2.76	70
	38	1.1/2	2	-2432	<b>T7290-2432</b>	5.12	130	7.32	186	1.26	32	<b>T7160-2432</b>	5.28	134	7.48	190	3.11	79
	51	2	2	-3232	<b>T7290-3232</b>	6.14	156	8.62	219	1.57	40	<b>T7160-3232</b>	6.61	168	9.09	231	3.74	95

**NOTE:** For SAE Code 61/62 and RYCO Code 62C Flange dimensions, see page 290.

**NOTE:** Hose Compatibility for the **T7000** series can be found on page 272.

## T7000 SERIES ONE-PIECE CRIMP COUPLINGS

<b>SAE FLANGE</b>	<b>T7170</b>	<b>T7171</b>
-------------------	--------------	--------------

RYCO  
CODE 61  
CLAMPS - SEE PAGES  
440 & 441  
O RING NOT SUPPLIED

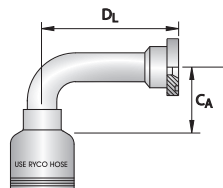
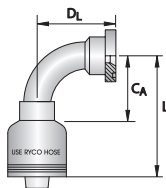

HOSE SIZE	NOM. FLANGE SIZE	DASH SIZE	CODE 61 FLANGE 90° TUBE BEND								CODE 61 FLANGE 90° SPECIAL TUBE BEND							
			PART NO		CA		L		DL		PART NO		CA		L		DL	
DN	inch	inch			inch	mm	inch	mm	inch	mm			inch	mm	inch	mm	inch	mm

12	1/2	1/2	-0808	<b>T7170-0808</b>	1.57	40	2.68	68	1.61	41									
12	1/2	3/4	-0812	<b>T7170-0812</b>	1.57	40	2.64	67	1.81	46	<b>T7171-0812</b>	2.01	51	3.11	79	2.87	73		
19	3/4	5/8	-1210	<b>T7170-1210</b>	2.01	51	3.23	82	1.89	48									
19	3/4	3/4	-1212	<b>T7170-1212</b>	2.17	55	3.39	86	2.13	54									
19	3/4	1	-1216	<b>T7170-1216</b>	2.17	55	3.39	86	2.36	60	<b>T7171-1216</b>	2.32	59	3.54	90	3.11	79		
25	1	3/4	-1612	<b>T7170-1612</b>	2.36	60	4.06	103	2.13	54									
25	1	1	-1616	<b>T7170-1616</b>	2.83	72	4.53	115	2.68	68									
25	1	1.1/4	-1620	<b>T7170-1620</b>	2.83	72	4.53	115	2.72	69									
25	1	1.1/2	-1624	<b>T7170-1624</b>	2.83	72	4.53	115	2.87	73									
31	1.1/4	1	-2016	<b>T7170-2016</b>	3.15	80	5.16	131	2.68	68									
31	1.1/4	1.1/4	-2020	<b>T7170-2020</b>	3.94	100	5.94	151	3.07	78									
31	1.1/4	1.1/2	-2024	<b>T7170-2024</b>	3.94	100	5.94	151	3.19	81	<b>T7171-2024</b>	3.94	100	5.94	151	3.19	81		
38	1.1/2	1.1/2	-2424	<b>T7170-2424</b>	4.09	104	6.30	160	3.66	93									
38	1.1/2	2	-2432	<b>T7170-2432</b>	3.82	97	6.02	153	3.90	99	<b>T7171-2432</b>	4.06	103	6.26	159	4.49	114		
51	2	2	-3232	<b>T7170-3232</b>	5.39	137	7.87	200	5.12	130	<b>T7171-3232</b>	5.43	138	7.91	201	6.50	165		
51	2	2.1/2	-3240	<b>T7170-3240</b>	5.55	141	8.03	204	5.28	134	<b>T7171-3240</b>	5.55	141	8.03	204	4.49	114		

**NOTE:** For SAE Code 61/62 and RYCO Code 62C Flange dimensions, see page 290.

<b>SAE FLANGE</b>	<b>T7172</b>	<b>T7173</b>
-------------------	--------------	--------------

RYCO  
CODE 61  
CLAMPS - SEE RYCO  
ADAPTOR CATALOGUE  
O RING NOT SUPPLIED

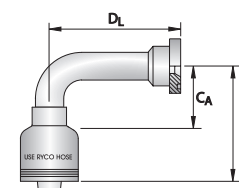
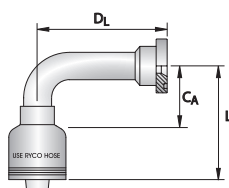

HOSE SIZE	NOM. FLANGE SIZE	DASH SIZE	CODE 61 FLANGE 90° SPECIAL TUBE BEND								CODE 61 FLANGE 90° LONG TUBE BEND							
			PART NO		CA		L		DL		PART NO		CA		L		DL	
DN	inch	inch			inch	mm	inch	mm	inch	mm			inch	mm	inch	mm	inch	mm

19	3/4	3/4	-1212	<b>T7172-1212</b>	2.32	59	3.54	90	3.74	95	<b>T7173-1212</b>	2.32	59	3.54	90	3.07	78		
25	1	1	-1616	<b>T7172-1616</b>	2.83	72	4.53	115	2.64	67	<b>T7173-1616</b>	2.83	72	4.53	115	3.70	94		
25	1	1.1/4	-1620								<b>T7173-1620</b>	2.83	72	4.53	115	3.66	93		
25	1	1.1/2	-1624	<b>T7172-1624</b>	2.83	72	4.53	115	4.25	108									
31	1.1/4	1.1/4	-2020	<b>T7172-2020</b>	3.94	100	5.94	151	3.62	92	<b>T7173-2020</b>	3.94	100	5.94	151	4.25	108		
31	1.1/4	1.1/2	-2024	<b>T7172-2024</b>	3.94	100	5.94	151	4.65	118									
38	1.1/2	1.1/2	-2424	<b>T7172-2424</b>	4.06	103	6.26	159	5.83	148									

**NOTE:** For SAE Code 61/62 and RYCO Code 62C Flange dimensions, see page 290.

**NOTE:** Hose Compatibility for the **T7000** series can be found on page 272.

INTRODUCTION

HOSE

COUPLINGS

ADAPTORS

TECHNICAL

# COUPLINGS

## T7000 SERIES ONE-PIECE CRIMP COUPLINGS

<b>SAE FLANGE</b>	<b>T7174</b>	<b>T7910</b>
-------------------	--------------	--------------

**RYCO  
CODE 61  
CLAMPS - SEE RYCO  
ADAPTOR CATALOGUE  
O RING NOT SUPPLIED**

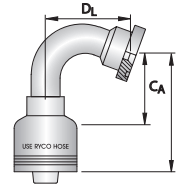
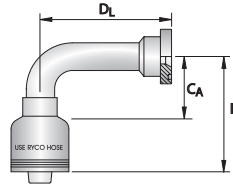

HOSE SIZE	NOM. FLANGE SIZE	DASH SIZE	CODE 61 FLANGE 90° SPECIAL TUBE BEND						CODE 61 FLANGE 110° TUBE BEND								
			PART NO		CA		L		DL		PART NO		CA		L		DL
DN	inch	inch		inch	mm	inch	mm	inch	mm		inch	mm	inch	mm	inch	mm	
19	3/4	3/4	-1212	<b>T7174-1212</b>	2.32	59	3.54	90	3.78	96	<b>T7910-1212</b>	2.87	73	4.06	103	2.64	67
25	1	1	-1616	<b>T7174-1616</b>	2.83	72	4.53	115	4.65	118	<b>T7910-1616</b>	3.23	82	4.92	125	3.15	80
25	1	1.1/4	-1620	<b>T7174-1620</b>	2.83	72	4.53	115	4.65	118	<b>T7910-1620</b>	3.23	82	4.92	125	3.35	85
31	1.1/4	1.1/4	-2020	<b>T7174-2020</b>	3.94	100	5.94	151	5.12	130	<b>T7910-2020</b>	3.54	90	5.55	141	3.74	95
31	1.1/4	1.1/2	-2024								<b>T7910-2024</b>	3.54	90	5.55	141	3.86	98
38	1.1/2	1.1/2	-2424	<b>T7174-2424</b>	3.86	98	6.06	154	5.83	148	<b>T7910-2424</b>	5.83	148	8.03	204	4.57	116
38	1.1/2	2	-2432	<b>T7174-2432</b>	4.09	104	6.30	160	6.77	172	<b>T7910-2432</b>	5.87	149	8.07	205	4.84	123
51	2	2	-3232	<b>T7174-3232</b>	5.55	141	8.03	204	7.99	203	<b>T7910-3232</b>	5.28	134	7.76	197	5.98	152

**NOTE:** For SAE Code 61/62 and RYCO Code 62C Flange dimensions, see page 290.

<b>SAE FLANGE</b>	<b>T7330</b>	<b>T7440</b>
-------------------	--------------	--------------

**RYCO  
CODE 62  
CLAMPS - SEE RYCO  
ADAPTOR CATALOGUE  
O RING NOT SUPPLIED**

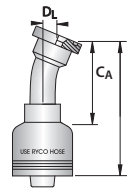
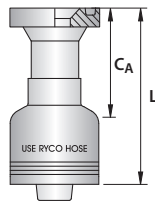

HOSE SIZE	NOM. FLANGE SIZE	DASH SIZE	CODE 62 FLANGE						CODE 62 FLANGE 22.5° TUBE BEND						
			PART NO		CA		L		PART NO		CA		L		DL
DN	inch	inch		inch	mm	inch	mm		inch	mm	inch	mm	inch	mm	
12	1/2	1/2	-0808	<b>T7330-0808</b>	1.81	46	2.87	73							
12	1/2	3/4	-0812	<b>T7330-0812</b>	2.24	57	3.31	84							
16	5/8	1/2	-1008	<b>T7330-1008</b>	1.77	45	3.07	78							
16	5/8	3/4	-1012	<b>T7330-1012</b>	2.20	56	3.50	89							
19	3/4	3/4	-1212	<b>T7330-1212</b>	2.01	51	3.23	82	<b>T7440-1212</b>	2.76	70	3.98	101	0.47	12
19	3/4	1	-1216	<b>T7330-1216</b>	2.13	54	3.35	85	<b>T7440-1216</b>	3.07	78	4.29	109	0.55	14
25	1	3/4	-1612	<b>T7330-1612</b>	2.09	53	3.78	96							
25	1	1	-1616	<b>T7330-1616</b>	2.20	56	3.90	99	<b>T7440-1616</b>	3.50	89	5.20	132	0.63	16
25	1	1.1/4	-1620	<b>T7330-1620</b>	2.64	67	4.33	110							
31	1.1/4	1	-2016	<b>T7330-2016</b>	2.76	70	4.76	121							
31	1.1/4	1.1/4	-2020	<b>T7330-2020</b>	2.76	70	4.76	121	<b>T7440-2020</b>	4.21	107	6.26	159	0.67	17
31	1.1/4	1.1/2	-2024	<b>T7330-2024</b>	3.90	99	5.91	150	<b>T7440-2024</b>	4.57	116	6.57	167	0.87	22
38	1.1/2	1.1/2	-2424	<b>T7330-2424</b>	3.90	99	6.14	156	<b>T7440-2424</b>	4.96	126	7.17	182	0.94	24
38	1.1/2	2	-2432	<b>T7330-2432</b>	4.61	117	6.85	174							
51	2	2	-3232	<b>T7330-3232</b>	4.65	118	7.09	180	<b>T7440-3232</b>	6.38	162	8.86	225	1.10	28

**NOTE:** For SAE Code 61/62 and RYCO Code 62C Flange dimensions, see page 290.

**NOTE:** Hose Compatibility for the **T7000** series can be found on page 272.

## T7000 SERIES ONE-PIECE CRIMP COUPLINGS

<b>SAE FLANGE</b>	<b>T7450</b>	<b>T7350</b>
-------------------	--------------	--------------

**RYCO  
CODE 62  
CLAMPS - SEE RYCO  
ADAPTOR CATALOGUE  
O RING NOT SUPPLIED**

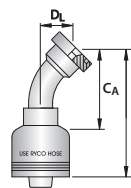
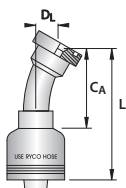

HOSE SIZE	NOM. FLANGE SIZE	DASH SIZE	CODE 62 FLANGE 30° TUBE BEND							CODE 62 FLANGE 45° TUBE BEND							
			DN	inch	inch	DASH	PART NO	CA	L	DL	PART NO	CA	L	DL			
					inch	mm	inch	mm	inch	mm	inch	mm	inch	mm			
12	1/2	1/2	-0808								<b>T7350-0808</b>	1.93	49	3.03	77	0.79	20
19	3/4	3/4	-1212	<b>T7450-1212</b>	2.87	73	4.09	104	0.75	19	<b>T7350-1212</b>	2.60	66	3.82	97	1.10	28
19	3/4	1	-1216								<b>T7350-1216</b>	2.76	70	3.98	101	1.22	31
25	1	3/4	-1612								<b>T7350-1612</b>	2.95	75	4.65	118	1.10	28
25	1	1	-1616	<b>T7450-1616</b>	3.46	88	5.16	131	0.87	22	<b>T7350-1616</b>	3.23	82	4.92	125	1.22	31
25	1	1.1/4	-1620	<b>T7450-1620</b>	3.54	90	5.24	133	0.87	22	<b>T7350-1620</b>	3.35	85	5.04	128	1.34	34
31	1.1/4	1	-2016								<b>T7350-2016</b>	3.50	89	5.51	140	1.26	32
31	1.1/4	1.1/4	-2020	<b>T7450-2020</b>	4.25	108	6.26	159	0.87	22	<b>T7350-2020</b>	3.86	98	5.87	149	1.50	38
31	1.1/4	1.1/2	-2024	<b>T7450-2024</b>	4.41	112	6.42	163	0.98	25	<b>T7350-2024</b>	4.02	102	6.02	153	1.61	41
38	1.1/2	1.1/2	-2424	<b>T7450-2424</b>	4.88	124	7.09	180	1.30	33	<b>T7350-2424</b>	4.45	113	6.65	169	1.73	44
38	1.1/2	2	-2432								<b>T7350-2432</b>	4.72	120	6.93	176	2.13	54
51	2	2	-3232								<b>T7350-3232</b>	5.98	152	8.46	215	2.36	60

**NOTE:** For SAE Code 61/62 and RYCO Code 62C Flange dimensions, see page 290.

<b>SAE FLANGE</b>	<b>T7460</b>	<b>T7360</b>
-------------------	--------------	--------------

**RYCO  
CODE 62  
CLAMPS - SEE RYCO  
ADAPTOR CATALOGUE  
O RING NOT SUPPLIED**

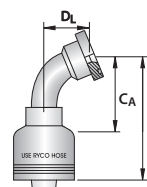
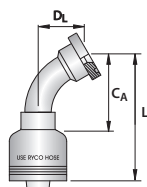

HOSE SIZE	NOM. FLANGE SIZE	DASH SIZE	CODE 62 FLANGE 60° TUBE BEND							CODE 62 FLANGE 67.5° TUBE BEND							
			DN	inch	inch	DASH	PART NO	CA	L	DL	PART NO	CA	L	DL			
					inch	mm	inch	mm	inch	mm	inch	mm	inch	mm			
19	3/4	3/4	-1212	<b>T7460-1212</b>	3.15	80	4.37	111	1.42	36	<b>T7360-1212</b>	2.87	73	4.09	104	1.85	47
19	3/4	1	-1216	<b>T7460-1216</b>	3.23	82	4.45	113	1.65	42	<b>T7360-1216</b>	2.91	74	4.13	105	1.89	48
25	1	1	-1616	<b>T7460-1616</b>	3.78	96	5.47	139	1.73	44	<b>T7360-1616</b>	3.43	87	5.12	130	2.01	51
25	1	1.1/4	-1620	<b>T7460-1620</b>	3.82	97	5.51	140	1.81	46	<b>T7360-1620</b>	3.62	92	5.31	135	2.52	64
31	1.1/4	1.1/4	-2020	<b>T7460-2020</b>	4.61	117	6.61	168	2.01	51	<b>T7360-2020</b>	4.45	113	6.46	164	2.83	72
31	1.1/4	1.1/2	-2024	<b>T7460-2024</b>	4.80	122	6.81	173	2.28	58	<b>T7360-2024</b>	4.45	113	6.46	164	2.91	74
38	1.1/2	1.1/2	-2424	<b>T7460-2424</b>	5.51	140	7.72	196	2.52	64							

**NOTE:** For SAE Code 61/62 and RYCO Code 62C Flange dimensions, see page 290.

**NOTE:** Hose Compatibility for the **T7000** series can be found on page 272.

INTRODUCTION

HOSE

COUPLINGS

ADAPTORS

TECHNICAL



# COUPLINGS

## T7000 SERIES ONE-PIECE CRIMP COUPLINGS

<b>SAE FLANGE</b>	<b>T7370</b>	<b>T7930</b>
-------------------	--------------	--------------

**RYCO  
CODE 62  
CLAMPS - SEE RYCO  
ADAPTOR CATALOGUE  
O RING NOT SUPPLIED**

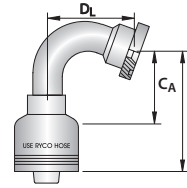
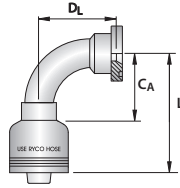

HOSE SIZE	NOM. FLANGE SIZE	DASH SIZE	CODE 62 FLANGE 90° TUBE BEND							CODE 62 FLANGE 110° TUBE BEND									
			PART NO		CA		L		DL		PART NO		CA		L		DL		
DN	inch	inch			inch	mm	inch	mm	inch	mm			inch	mm	inch	mm	inch	mm	
12	1/2	1/2	-0808	<b>T7370-0808</b>	1.65	42	2.76	70	1.61	41									
12	1/2	3/4	-0812	<b>T7370-0812</b>	1.65	42	2.76	70	1.81	46									
16	5/8	1/2	-1008	<b>T7370-1008</b>	1.77	45	3.07	78	1.65	42									
16	5/8	3/4	-1012	<b>T7370-1012</b>	1.89	48	3.19	81	2.20	56									
19	3/4	3/4	-1212	<b>T7370-1212</b>	2.32	59	3.54	90	2.20	56									
19	3/4	1	-1216	<b>T7370-1216</b>	2.32	59	3.54	90	2.40	61									
25	1	3/4	-1612	<b>T7370-1612</b>	2.36	60	4.06	103	2.20	56									
25	1	1	-1616	<b>T7370-1616</b>	2.83	72	4.53	115	2.76	70									
25	1	1.1/4	-1620	<b>T7370-1620</b>	2.83	72	4.53	115	2.80	71									
31	1.1/4	1	-2016	<b>T7370-2016</b>	3.15	80	5.16	131	2.76	70									
31	1.1/4	1.1/4	-2020	<b>T7370-2020</b>	3.94	100	5.94	151	3.15	80									
31	1.1/4	1.1/2	-2024	<b>T7370-2024</b>	3.94	100	5.94	151	3.39	86									
38	1.1/2	1.1/4	-2420	<b>T7370-2420</b>	3.50	89	5.71	145	3.15	80									
38	1.1/2	1.1/2	-2424	<b>T7370-2424</b>	3.86	98	6.06	154	3.86	98	<b>T7930-2424</b>	5.59	142	7.80	198	4.69	119		
38	1.1/2	2	-2432	<b>T7370-2432</b>	4.09	104	6.30	160	4.09	104	<b>T7930-2432</b>	5.91	150	8.11	206	4.96	126		
51	2	2	-3232	<b>T7370-3232</b>	5.39	137	7.87	200	5.16	131	<b>T7930-3232</b>	5.28	134	7.76	197	6.02	153		

**NOTE:** For SAE Code 61/62 and RYCO Code 62C Flange dimensions, see page 290.

<b>SPECIAL FLANGE</b>	<b>T7333</b>	<b>T7443</b>
-----------------------	--------------	--------------

**RYCO  
CODE 62C  
O RING NOT SUPPLIED**

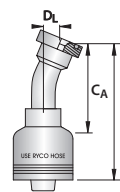
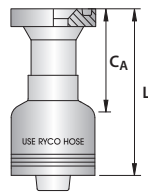

HOSE SIZE	NOM. FLANGE SIZE	DASH SIZE	RYCO CODE 62C FLANGE							RYCO CODE 62C FLANGE 22.5° TUBE BEND									
			PART NO		CA		L		DL		PART NO		CA		L		DL		
DN	inch	inch			inch	mm	inch	mm	inch	mm			inch	mm	inch	mm	inch	mm	
19	3/4	3/4	-1212	<b>T7333-1212</b>	2.44	62	3.66	93			<b>T7443-1212</b>	3.11	79	4.33	110	0.59	15		
19	3/4	1	-1216	<b>T7333-1216</b>	2.44	62	3.66	93			<b>T7443-1216</b>	3.35	85	4.57	116	0.79	20		
25	1	1	-1616	<b>T7333-1616</b>	2.52	64	4.21	107			<b>T7443-1616</b>	3.50	89	5.20	132	0.63	16		
25	1	1.1/4	-1620	<b>T7333-1620</b>	2.80	71	4.49	114			<b>T7443-1620</b>	3.66	93	5.35	136	0.63	16		
31	1.1/4	1.1/4	-2020	<b>T7333-2020</b>	3.43	87	5.43	138			<b>T7443-2020</b>	4.21	107	6.22	158	0.67	17		
31	1.1/4	1.1/2	-2024	<b>T7333-2024</b>	3.43	87	5.43	138			<b>T7443-2024</b>	5.39	137	7.40	188	0.87	22		
38	1.1/2	1.1/2	-2424	<b>T7333-2424</b>	3.98	101	6.18	157			<b>T7443-2424</b>	4.96	126	7.17	182	0.94	24		
51	2	2	-3232	<b>T7333-3232</b>	4.17	106	6.61	168											

**NOTE:** These **T7000** fittings have similar end styles to Caterpillar® XT-3 range of Flanged Hose Couplings. Cat™ Caterpillar®, XT-3™ Caterpillar®  
For SAE Code 61/62 and RYCO Code 62C Flange dimensions, see page 290.

**NOTE:** Hose Compatibility for the **T7000** series can be found on page 272.

## T7000 SERIES ONE-PIECE CRIMP COUPLINGS

<b>SPECIAL FLANGE</b>	<b>T7444</b>	<b>T7453</b>
-----------------------	--------------	--------------

**RYCO  
CODE 62C  
O RING NOT SUPPLIED**

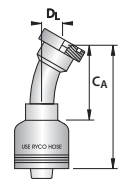
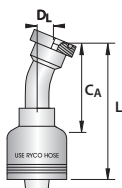

HOSE SIZE				NOM. FLANGE SIZE	DASH SIZE	RYCO CODE 62C D-RING FLANGE 22.5° TUBE BEND						RYCO CODE 62C FLANGE 30° TUBE BEND					
DN	inch	inch		PART NO	CA		L		DL		PART NO	CA		L		DL	
					inch	mm	inch	mm	inch	mm		inch	mm	inch	mm	inch	mm
19	3/4	3/4	-1212	<b>T7444-1212</b>	3.11	79	4.33	110	0.59	15	<b>T7453-1212</b>	3.23	82	4.45	113	0.91	23
25	1	1	-1616	<b>T7444-1616</b>	3.50	89	5.20	132	0.63	16	<b>T7453-1616</b>	4.25	108	5.94	151	0.94	24
25	1	1.1/4	-1620	<b>T7444-1620</b>	3.66	93	5.35	136	0.63	16	<b>T7453-1620</b>	4.37	111	6.06	154	0.98	25
31	1.1/4	1.1/4	-2020	<b>T7444-2020</b>	4.21	107	6.22	158	0.67	17	<b>T7453-2020</b>	4.53	115	6.54	166	0.98	25
31	1.1/4	1.1/2									<b>T7453-2024</b>	4.49	114	6.50	165	1.02	26
38	1.1/2	1.1/2									<b>T7453-2424</b>	5.00	127	7.20	183	1.18	30

**NOTE:** These **T7000** fittings have similar end styles to Caterpillar® XT-3 range of Flanged Hose Couplings. Cat™ Caterpillar®, XT-3™ Caterpillar® For SAE Code 61/62 and RYCO Code 62C Flange dimensions, see page 290.

<b>SPECIAL FLANGE</b>	<b>T7454</b>	<b>T7353</b>
-----------------------	--------------	--------------

**RYCO  
CODE 62C  
O RING NOT SUPPLIED**

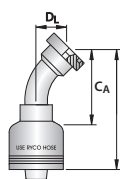
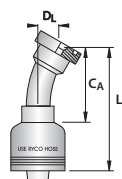

HOSE SIZE				NOM. FLANGE SIZE	DASH SIZE	RYCO CODE 62C D-RING FLANGE 30° TUBE BEND						RYCO CODE 62C FLANGE 45° TUBE BEND					
DN	inch	inch		PART NO	CA		L		DL		PART NO	CA		L		DL	
					inch	mm	inch	mm	inch	mm		inch	mm	inch	mm	inch	mm
19	3/4	3/4	-1212	<b>T7454-1212</b>	3.23	82	4.45	113	0.91	23	<b>T7353-1212</b>	2.72	69	3.94	100	1.22	31
19	3/4	1	-1216								<b>T7353-1216</b>	2.83	72	4.06	103	1.30	33
25	1	1	-1616	<b>T7454-1616</b>	3.46	88	5.16	131	0.94	24	<b>T7353-1616</b>	3.54	90	5.24	133	1.38	35
25	1	1.1/4	-1620								<b>T7353-1620</b>	3.43	87	5.12	130	1.46	37
31	1.1/4	1.1/4	-2020	<b>T7454-2020</b>	4.53	115	6.54	166	0.98	25	<b>T7353-2020</b>	4.17	106	6.18	157	1.61	41
31	1.1/4	1.1/2	-2024	<b>T7454-2024</b>	4.53	115	6.54	166	1.02	26	<b>T7353-2024</b>	4.25	108	6.26	159	1.69	43
38	1.1/2	1.1/2	-2424								<b>T7353-2424</b>	4.53	115	6.73	171	1.81	46
51	2	2	-3232								<b>T7353-3232</b>	6.14	156	8.62	219	2.40	61

**NOTE:** These **T7000** fittings have similar end styles to Caterpillar® XT-3 range of Flanged Hose Couplings. Cat™ Caterpillar®, XT-3™ Caterpillar® For SAE Code 61/62 and RYCO Code 62C Flange dimensions, see page 290.

**NOTE:** Hose Compatibility for the **T7000** series can be found on page 272.

INTRODUCTION

HOSE

COUPLINGS

ADAPTORS

TECHNICAL

# COUPLINGS

## T7000 SERIES ONE-PIECE CRIMP COUPLINGS

<b>SPECIAL FLANGE</b>	<b>T7354</b>	<b>T7463</b>
-----------------------	--------------	--------------

**RYCO  
CODE 62C  
O RING NOT SUPPLIED**

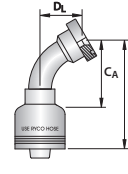
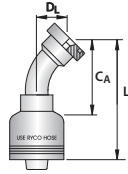

HOSE SIZE	NOM. FLANGE SIZE	DASH SIZE	RYCO CODE 62C D-RING FLANGE 45° TUBE BEND								RYCO CODE 62C FLANGE 60° TUBE BEND								
			PART NO		CA		L		DL		PART NO		CA		L		DL		
DN	inch	inch			inch	mm	inch	mm	inch	mm			inch	mm	inch	mm	inch	mm	
19	3/4	3/4	-1212	<b>T7354-1212</b>	2.72	69	3.94	100	1.22	31	<b>T7463-1212</b>	3.23	82	4.45	113	1.65	42		
19	3/4	1	-1216	<b>T7354-1216</b>	1.22	31	2.44	62	1.30	33	<b>T7463-1216</b>	3.27	83	4.49	114	1.85	47		
25	1	1	-1616	<b>T7354-1616</b>	3.54	90	5.24	133	1.38	35	<b>T7463-1616</b>	3.78	96	5.47	139	1.85	47		
25	1	1.1/4	-1620	<b>T7354-1620</b>	3.23	82	4.92	125	1.46	37	<b>T7463-1620</b>	4.02	102	5.71	145	1.93	49		
31	1.1/4	1.1/4	-2020	<b>T7354-2020</b>	4.09	104	6.10	155	1.61	41	<b>T7463-2020</b>	4.72	120	6.73	171	2.20	56		
31	1.1/4	1.1/2	-2024	<b>T7354-2024</b>	4.09	104	6.10	155	1.69	43	<b>T7463-2024</b>	4.53	115	6.54	166	2.60	66		
38	1.1/2	1.1/2	-2424								<b>T7463-2424</b>	5.67	144	7.87	200	2.68	68		

**NOTE:** These **T7000** fittings have similar end styles to Caterpillar® XT-3 range of Flanged Hose Couplings. Cat™ Caterpillar®, XT-3™ Caterpillar® For SAE Code 61/62 and RYCO Code 62C Flange dimensions, see page 290.

<b>SPECIAL FLANGE</b>	<b>T7464</b>	<b>T7363</b>
-----------------------	--------------	--------------

**RYCO  
CODE 62C  
O RING NOT SUPPLIED**

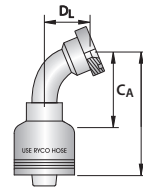
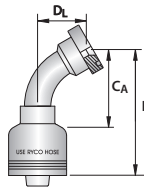

HOSE SIZE	NOM. FLANGE SIZE	DASH SIZE	RYCO CODE 62C D-RING FLANGE 60° TUBE BEND								RYCO CODE 62C FLANGE 67.5° TUBE BEND								
			PART NO		CA		L		DL		PART NO		CA		L		DL		
DN	inch	inch			inch	mm	inch	mm	inch	mm			inch	mm	inch	mm	inch	mm	
19	3/4	3/4	-1212	<b>T7464-1212</b>	3.23	82	4.45	113	1.65	42	<b>T7363-1212</b>	2.95	75	4.17	106	2.05	52		
19	3/4	1	-1216	<b>T7464-1216</b>	1.22	31	2.44	62	1.65	42	<b>T7363-1216</b>	3.11	79	4.33	110	2.09	53		
25	1	1	-1616	<b>T7464-1616</b>	3.78	96	5.47	139	1.85	47	<b>T7363-1616</b>	3.58	91	5.28	134	2.09	53		
25	1	1.1/4	-1620	<b>T7464-1620</b>	3.98	101	5.67	144	1.93	49	<b>T7363-1620</b>	3.62	92	5.31	135	2.20	56		
31	1.1/4	1.1/4	-2020	<b>T7464-2020</b>	4.72	120	6.73	171	2.20	56	<b>T7363-2020</b>	4.45	113	6.46	164	2.64	67		
31	1.1/4	1.1/2	-2024	<b>T7464-2024</b>	4.57	116	6.57	167	2.60	66	<b>T7363-2024</b>	5.35	136	7.36	187	2.99	76		
38	1.1/2	1.1/2	-2424								<b>T7363-2424</b>	5.35	136	7.56	192	3.03	77		

**NOTE:** These **T7000** fittings have similar end styles to Caterpillar® XT-3 range of Flanged Hose Couplings. Cat™ Caterpillar®, XT-3™ Caterpillar®. For SAE Code 61/62 and RYCO Code 62C Flange dimensions, see page 290.

**NOTE:** Hose Compatibility for the **T7000** series can be found on page 272.

## T7000 SERIES ONE-PIECE CRIMP COUPLINGS

### SPECIAL FLANGE T7364

RYCO  
CODE 62C  
O RING NOT SUPPLIED

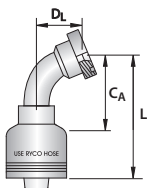

HOSE SIZE	NOM. FLANGE SIZE	DASH SIZE	RYCO CODE 62C D-RING FLANGE 67.5° TUBE BEND							
-----------	------------------	-----------	---	--	--	--	--	--	--	--

DN	inch	inch		PART NO	CA		L		DL	
					inch	mm	inch	mm	inch	mm
19	3/4	3/4	-1212	<b>T7364-1212</b>	3.11	79	4.33	110	2.05	52
19	3/4	1	-1216	<b>T7364-1216</b>	1.22	31	2.44	62	2.09	53
25	1	1	-1616	<b>T7364-1616</b>	3.58	91	5.28	134	2.09	53
25	1	1.1/4	-1620	<b>T7364-1620</b>	3.62	92	5.31	135	2.20	56
31	1.1/4	1.1/4	-2020	<b>T7364-2020</b>	4.45	113	6.46	164	2.64	67
31	1.1/4	1.1/2	-2024	<b>T7364-2024</b>	4.17	106	6.18	157	2.99	76

**NOTE:** These **T7000** fittings have similar end styles to Caterpillar® XT-3 range of Flanged Hose Couplings. Cat™ Caterpillar®, XT-3™ Caterpillar®. For SAE Code 61/62 and RYCO Code 62C Flange dimensions, see page 290.

### SPECIAL FLANGE T7373 T7378

RYCO  
CODE 62C  
O RING NOT SUPPLIED

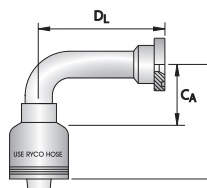
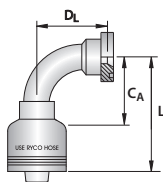

HOSE SIZE	NOM. FLANGE SIZE	DASH SIZE	RYCO CODE 62C FLANGE 90° TUBE BEND							RYCO CODE 62C FLANGE 90° TUBE BEND						
-----------	------------------	-----------	------------------------------------	--	--	--	--	--	--	------------------------------------	--	--	--	--	--	--

DN	inch	inch		PART NO	CA		L		DL		PART NO	CA		L		DL	
					inch	mm	inch	mm	inch	mm		inch	mm	inch	mm		
19	3/4	3/4	-1212	<b>T7373-1212</b>	2.32	59	3.54	90	2.44	62							
19	3/4	1	-1216	<b>T7373-1216</b>	2.32	59	3.54	90	2.60	66							
25	1	1	-1616	<b>T7373-1616</b>	2.83	72	4.53	115	2.83	72							
25	1	1.1/4	-1620	<b>T7373-1620</b>	2.83	72	4.53	115	2.95	75							
31	1.1/4	1.1/4	-2020	<b>T7373-2020</b>	3.94	100	5.94	151	3.27	83	<b>T7378-2020</b>	3.94	100	5.94	151	5.91	150
31	1.1/4	1.1/2	-2024	<b>T7373-2024</b>	3.94	100	5.94	151	3.35	85	<b>T7378-2024</b>	3.94	100	5.94	151	5.31	135
38	1.1/2	1.1/2	-2424	<b>T7373-2424</b>	3.86	98	6.06	154	3.78	96							
51	2	2	-3232	<b>T7373-3232</b>	5.39	137	7.87	200	5.24	133							

**NOTE:** These **T7000** fittings have similar end styles to Caterpillar® XT-3 range of Flanged Hose Couplings. Cat™ Caterpillar®, XT-3™ Caterpillar®. For SAE Code 61/62 and RYCO Code 62C Flange dimensions, see page 290.

**NOTE:** Hose Compatibility for the **T7000** series can be found on page 272.

INTRODUCTION

HOSE

COUPLINGS

ADAPTORS

TECHNICAL

# COUPLINGS

## T7000 SERIES ONE-PIECE CRIMP COUPLINGS

<b>SPECIAL FLANGE</b>	<b>T7374</b>	<b>T7933</b>
-----------------------	--------------	--------------

**RYCO  
CODE 62C  
O RING NOT SUPPLIED**

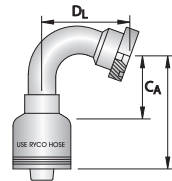
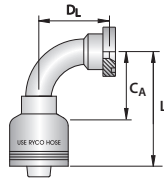

HOSE SIZE				NOM. FLANGE SIZE	DASH SIZE	RYCO CODE 62C D-RING FLANGE 110° TUBE BEND						RYCO CODE 62C FLANGE 110° TUBE BEND						
DN	inch	inch		PART NO	CA		L		DL		PART NO	CA		L		DL		
					inch	mm	inch	mm	inch	mm		inch	mm	inch	mm	inch	mm	
19	3/4	3/4	-1212	<b>T7374-1212</b>	2.32	59	3.54	90	2.44	62								
19	3/4	1	-1216	<b>T7374-1216</b>	2.32	59	3.54	90	2.60	66								
25	1	1	-1616	<b>T7374-1616</b>	2.83	72	4.53	115	2.83	72								
25	1	1.1/4	-1620	<b>T7374-1620</b>	2.83	72	4.53	115	2.95	75								
31	1.1/4	1.1/4	-2020	<b>T7374-2020</b>	3.94	100	5.94	151	3.27	83								
31	1.1/4	1.1/2	-2024	<b>T7374-2024</b>	3.94	100	5.94	151	3.35	85								
38	1.1/2	1.1/2	-2424								<b>T7933-2424</b>	5.55	141	7.76	197	4.72	120	

**NOTE:** These **T7000** fittings have similar end styles to Caterpillar® XT-3 range of Flanged Hose Couplings. Cat™ Caterpillar®, XT-3™ Caterpillar®. For SAE Code 61/62 and RYCO Code 62C Flange dimensions, see page 290.

<b>STANDPIPE</b>	<b>T7640</b>	<b>T7643</b>
------------------	--------------	--------------

**METRIC**

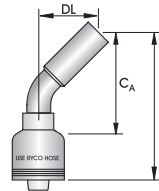
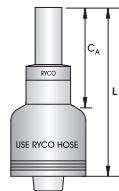

HOSE SIZE				TUBE SIZE	DASH SIZE	METRIC STANDPIPE				METRIC STANDPIPE 45° TUBE BEND					
DN	inch	mm		PART NO	CA		L		PART NO	CA		L		DL	
					inch	mm	inch	mm		inch	mm	inch	mm	inch	mm
12	1/2	14	-0814	<b>T7640-0814</b>	1.77	45	2.83	72							
19	3/4	20	-1220	<b>T7640-1220</b>	2.09	53	3.31	84							
31	1.1/4	30	-2030	<b>T7640-2030</b>	2.64	67	4.65	118							

**NOTE:** See RYCO Adaptor Catalogue for DKL and DKS Metric Nuts and Olives for use with Metric Standpipe Fittings.

**NOTE:** Hose Compatibility for the **T7000** series can be found on page 272.

## T7000 SERIES ONE-PIECE CRIMP COUPLINGS

<b>SALVAGE</b>	<b>T7230</b>
----------------	--------------

**TUBE WELD**

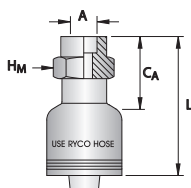

HOSE SIZE		A		DASH SIZE	MALE HEX		SALVAGE (LIFESAVER)						
DN	inch	inch	mm		inch	mm	HM-SPANNER	PART NO		CA		L	
								inch	mm	inch	mm	inch	mm
12	1/2	1/2	12.7	-0808	3/4	19		<b>T7230-0808</b>	1.06	27	2.17	55	
12	1/2	5/8	15.9	-0810	15/16	24		<b>T7230-0810</b>	1.14	29	2.20	56	
19	3/4	5/8	15.9	-1210	15/16	24		<b>T7230-1210</b>	1.18	30	2.40	61	
19	3/4	3/4	19.1	-1212	1.1/16	27		<b>T7230-1212</b>	1.18	30	2.40	61	
19	3/4	1	25.4	-1216	1.3/8			<b>T7230-1216</b>	1.38	35	2.60	66	
25	1	3/4	19.1	-1612	1.1/16	27		<b>T7230-1612</b>	1.18	30	2.87	73	
25	1	1	25.4	-1616	1.3/8			<b>T7230-1616</b>	1.38	35	3.07	78	
25	1	1.1/4	31.8	-1620	1.5/8	41		<b>T7230-1620</b>	1.42	36	3.11	79	
31	1.1/4	1	25.4	-2016	1.3/8			<b>T7230-2016</b>	1.54	39	3.54	90	
31	1.1/4	1.1/4	31.8	-2020	1.5/8	41		<b>T7230-2020</b>	1.57	40	3.58	91	
38	1.1/2	1.1/2	38.1	-2424	2	50		<b>T7230-2424</b>	1.34	34	3.54	90	
51	2	2	50.8	-3232	2.1/2			<b>T7230-3232</b>	1.61	41	4.09	104	

**WARNING:** Due to high pressures involved, special care must be taken when using **T7230** Salvage Couplings. See Clause 8 of the Terms & Conditions of Sale.

**NOTE:** Hose Compatibility for the **T7000** series can be found on page 272.

INTRODUCTION

HOSE

COUPLINGS

ADAPTORS

TECHNICAL



# COUPLINGS

## T7000 SERIES ONE-PIECE CRIMP COUPLINGS

<b>UNO (O RING BOSS)</b>	<b>T7200</b>
--------------------------	--------------

O RING SUPPLIED

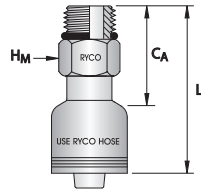

HOSE SIZE		THRD SIZE	TUBE SIZE	DASH SIZE	MALE HEX		UN O RING MALE					
DN	inch	inch	inch		HM-SPANNER		PART NO	CA		L		
	inch	inch	inch		inch	mm		inch	mm	inch	mm	
19	3/4	1.1/16	3/4	-1217	1.1/4	32	<b>T7200-1217</b>	1.73	44	2.95	75	
25	1	1.5/16	1	-1621	1.1/2	38	<b>T7200-1621</b>	1.73	44	3.43	87	

<b>HAMMER UNION</b>	<b>T71502</b>	<b>T71501</b>
---------------------	---------------	---------------

FIGURE 1502  
STANDARD SERVICE

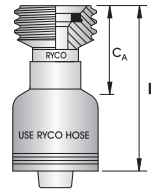
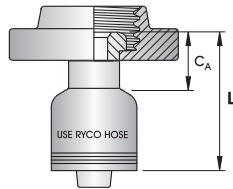

HOSE SIZE		THRD SIZE	DASH SIZE	FIG 1502 MALE (WITH NUT)				FIG 1502 FEMALE (WITH SEAL)							
DN	inch	inch		PART NO		CA		L		PART NO		CA		L	
	inch	inch		inch	mm	inch	mm	inch	mm	inch	mm	inch	mm	inch	mm
38	1.1/2	4.1/8	-2432	<b>T71502-2432</b>	4.33	110	6.57	167	<b>T71501-2432</b>	3.58	91	5.83	148		
51	2	4.1/8	-3232	<b>T71502-3232</b>	4.37	111	6.81	173	<b>T71501-3232</b>	3.62	92	6.06	154		

**NOTE:** Nut must be installed onto hose before coupling is installed and crimped. Replacement parts **RF1502N-32** nut and **RF1502W-32** Nitrile seal are available.

**NOTE:** Hose Compatibility for the **T7000** series can be found on page 272.

## TP000 SERIES ONE-PIECE CRIMP COUPLINGS

### HOSE COMPATIBILITY FOR TP000 SERIES

#### NON-SKIVE

For RYCO Hose Series TP7, TP7N, TP7T, TP7TN, TP8, TP8N, TP8T, TP8TN, TP3000 (all sizes).

#### BSPT

#### TP010

60° SEAT

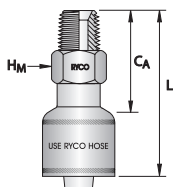

HOSE SIZE		THRD SIZE	DASH SIZE	BACK UP AF		BSPT MALE				
DN	inch	inch		AF-SPANNER		PART NO	C <sub>A</sub>		L	
				inch	mm		inch	mm	inch	mm
6	1/4	1/4	-0404		14	<b>TP010-0404</b>	1.10	28	2.17	55
6	1/4	3/8	-0406	3/4	19	<b>TP010-0406</b>	1.14	29	2.17	55
8	5/16	3/8	-0506	3/4	19	<b>TP010-0506</b>	1.14	29	2.17	55
10	3/8	1/4	-0604		14	<b>TP010-0604</b>	1.10	28	2.17	55
10	3/8	3/8	-0606	3/4	19	<b>TP010-0606</b>	1.14	29	2.20	56
10	3/8	1/2	-0608	7/8	22	<b>TP010-0608</b>	1.38	35	2.48	63
12	1/2	3/8	-0806	3/4	19	<b>TP010-0806</b>	1.18	30	2.36	60
12	1/2	1/2	-0808	7/8	22	<b>TP010-0808</b>	1.38	35	2.60	66
16	5/8	3/4	-1012	#N/A	#N/A	<b>TP010-1012</b>				
19	3/4	3/4	-1212	1.1/16	27	<b>TP010-1212</b>	0.71	18	2.17	55
25	1	1	-1616		36	<b>TP010-1616</b>	1.81	46	3.31	84

**NOTE:** Hose Compatibility for the **TP000** series can be found on page 303.

# COUPLINGS

<b>BSPP</b>	<b>TP020</b>	<b>TP050</b>
-------------	--------------	--------------

60° SEAT

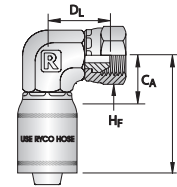
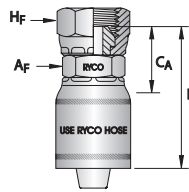

HOSE SIZE		THRD SIZE	DASH SIZE	BACK UP Af		FEMALE HEX		BSPP FEMALE				BSPP FEMALE 90° ELBOW										
DN	inch	inch		Af-SPANNER		Hf-SPANNER		PART NO		CA		L		PART NO		CA		L		DL		
				inch	mm	inch	mm			inch	mm	inch	mm			inch	mm	inch	mm	inch	mm	
5	3/16	1/4	-0304		12	3/4	19	<b>TP020-0304</b>	0.91	23	1.89	48										
6	1/4	1/8	-0402		12		14	<b>TP020-0402</b>	0.91	23	1.93	49										
6	1/4	1/4	-0404		12	3/4	19	<b>TP020-0404</b>	0.91	23	1.97	50	<b>TP050-0404</b>	0.87	22	1.93	49	0.94	24			
6	1/4	3/8	-0406	5/8	16	7/8	22	<b>TP020-0406</b>	1.02	26	2.09	53										
8	5/16	1/4	-0504		12	3/4	19	<b>TP020-0504</b>	0.91	23	1.97	50										
8	5/16	3/8	-0506	5/8	16	7/8	22	<b>TP020-0506</b>	1.02	26	2.09	53										
10	3/8	1/4	-0604		12	3/4	19	<b>TP020-0604</b>	0.91	23	1.97	50										
10	3/8	3/8	-0606	5/8	16	7/8	22	<b>TP020-0606</b>	1.02	26	2.13	54	<b>TP050-0606</b>	0.91	23	1.97	50	1.10	28			
10	3/8	1/2	-0608	3/4	19	1.1/16	27	<b>TP020-0608</b>	1.14	29	2.20	56										
12	1/2	1/2	-0808	3/4	19	1.1/16	27	<b>TP020-0808</b>	1.14	29	2.32	59	<b>TP050-0808</b>	1.14	29	2.32	59	1.22	31			
12	1/2	5/8	-0810	7/8	22	1.3/16	30	<b>TP020-0810</b>	1.10	28	2.28	58										
12	1/2	3/4	-0812	1.1/16	27	1.1/4	32	<b>TP020-0812</b>	1.26	32	2.44	62										
16	5/8	5/8	-1010			1.3/16	30	<b>TP020-1010</b>														
19	3/4	3/4	-1212	1.1/16	27	1.1/4	32	<b>TP020-1212</b>	1.26	32	2.68	68										
25	1	1	-1616	1.1/4	32	1.1/2	38	<b>TP020-1616</b>	1.61	41	3.11	79										

<b>BSPP</b>	<b>TP122</b>	<b>TP260</b>
-------------	--------------	--------------

60° SEAT

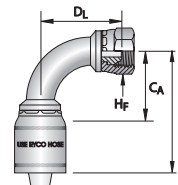
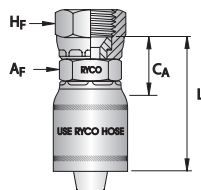

HOSE SIZE		THRD SIZE	DASH SIZE	BACK UP Af		FEMALE HEX		BSPP FEMALE 60° CONCAVE SEAT (JIS)				BSPP FEMALE 90° TUBE BEND										
DN	inch	inch		Af-SPANNER		Hf-SPANNER		PART NO		CA		L		PART NO		CA		L		DL		
				inch	mm	inch	mm			inch	mm	inch	mm			inch	mm	inch	mm	inch	mm	
6	1/4	1/4	-0404		14	3/4	19	<b>TP122-0404</b>	0.91	23	1.97	50	<b>TP260-0404</b>	1.10	28	2.13	54	1.14	29			
6	1/4	3/8	-0406			7/8	22						<b>TP260-0406</b>	1.10	28	2.13	54	1.10	28			
10	3/8	3/8	-0606	5/8	16	7/8	22	<b>TP122-0606</b>	0.94	24	2.01	51	<b>TP260-0606</b>	1.38	35	2.44	62	1.30	33			
10	3/8	1/2	-0608	7/8	22	1.1/16	27	<b>TP122-0608</b>	1.06	27	2.17	55	<b>TP260-0608</b>	1.38	35	2.44	62	1.30	33			
12	1/2	1/2	-0808	7/8	22	1.1/16	27	<b>TP122-0808</b>	1.06	27	2.28	58	<b>TP260-0808</b>	1.50	38	2.68	68	1.77	45			
12	1/2	5/8	-0810			1.3/16	30						<b>TP260-0810</b>	1.57	40	2.76	70	1.77	45			
19	3/4	3/4	-1212	1.1/16	27		36	<b>TP122-1212</b>	1.18	30	2.60	66	<b>TP260-1212</b>	2.17	55	3.50	89	2.32	59			
25	1	1	-1616			1.1/2	38						<b>TP260-1616</b>	2.68	68	4.09	104	3.07	78			

## TP000 SERIES ONE-PIECE CRIMP COUPLINGS

<b>BSPP</b>	<b>TP270</b>
-------------	--------------

**60° SEAT**

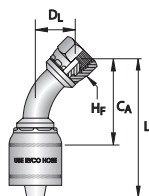

HOSE SIZE		THRD SIZE	DASH SIZE	FEMALE HEX		BSPP FEMALE 45° TUBE BEND						
DN	inch	inch		HF-SPANNER		PART NO	CA		L		DL	
	inch	inch		inch	mm		inch	mm	inch	mm	inch	mm
6	1/4	1/4	-0404	3/4	19	<b>TP270-0404</b>	1.42	36	2.44	62	0.67	17
10	3/8	3/8	-0606	7/8	22	<b>TP270-0606</b>	1.73	44	2.80	71	0.71	18
12	1/2	1/2	-0808	1.1/16	27	<b>TP270-0808</b>	1.97	50	3.15	80	0.87	22
19	3/4	3/4	-1212	1.1/4	32	<b>TP270-1212</b>	2.76	70	4.09	104	1.14	29
25	1	1	-1616	1.1/2	38	<b>TP270-1616</b>	3.35	85	4.76	121	1.65	42

<b>BSP - BANJO</b>	<b>TP475</b>
--------------------	--------------

**STRAIGHT**

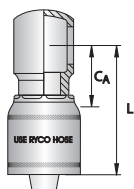

HOSE SIZE		THRD SIZE	DASH SIZE	BSP BANJO					
DN	inch	inch		PART NO		CA		L	
	inch	inch		inch	mm	inch	mm	inch	mm
6	1/4	1/4	-0404	<b>TP475-0404</b>	0.98	25	2.05	52	
6	1/4	3/8	-0406						
8	5/16	3/8	-0506	<b>TP475-0506</b>	1.06	27	2.13	54	
10	3/8	1/4	-0604						
10	3/8	3/8	-0606	<b>TP475-0606</b>	1.06	27	2.17	55	
10	3/8	1/2	-0608	<b>TP475-0608</b>	1.10	28	2.20	56	
12	1/2	1/2	-0808	<b>TP475-0808</b>	1.10	28	2.32	59	
19	3/4	3/4	-1212	<b>TP475-1212</b>	1.22	31	2.68	68	
25	1	1	-1616	<b>TP475-1616</b>	1.57	40	3.03	77	

**NOTE:** Hose Compatibility for the **TP000** series can be found on page 303.

INTRODUCTION

HOSE

COUPLINGS

ADAPTORS

TECHNICAL

# COUPLINGS

## TP000 SERIES ONE-PIECE CRIMP COUPLINGS

<b>BSP BANJO BOLT</b>	<b>BBB</b>
-----------------------	------------

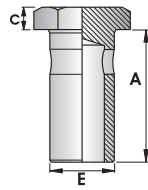

THREAD SIZE E	DIMENSIONS (MM)			BSP BANJO BOLT
	A	C	A/F	
inch				PART NO
G1/4"-19	28,5	6,0	19	<b>BBB-04</b>
G3/8"-19	38,5	7,0	22	<b>BBB-06</b>
G1/2"-14	44,0	8,5	27	<b>BBB-08</b>
G5/8"-14	48,5	10,0	30	<b>BBB-10</b>
G3/4"-14	56,0	10,0	32	<b>BBB-12</b>
G1"-11	68,5	13,0	41	<b>BBB-16</b>

**NOTE:** RL21D Seals for BBB Banjo Bolts can be found on page 402.

<b>NPT</b>	<b>TP090</b>	<b>TP340N</b>
------------	--------------	---------------

60° SEAT

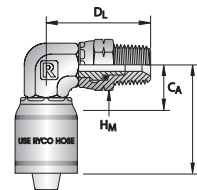
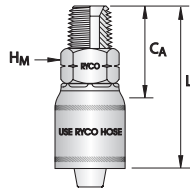

HOSE SIZE	THRD SIZE	DASH SIZE	MALE HEX	NPT MALE				NPT MALE SWIVEL 90° ELBOW										
				HM-SPANNER		PART NO		CA		L		PART NO		CA		L		DL
DN	inch	inch		inch	mm	inch	mm	inch	mm	inch	mm	inch	mm	inch	mm	inch	mm	
5	3/16	1/8	-0302	1/2		<b>TP090-0302</b>	0.91	23	1.93	49								
5	3/16	1/4	-0304	9/16		<b>TP090-0304</b>	1.10	28	2.13	54	<b>TP340N-0304</b>	0.87	22	1.85	47	1.61	41	
6	1/4	1/8	-0402	1/2		<b>TP090-0402</b>	0.94	24	1.97	50								
6	1/4	1/4	-0404	9/16		<b>TP090-0404</b>	1.10	28	2.17	55	<b>TP340N-0404</b>	0.87	22	1.93	49	1.61	41	
6	1/4	3/8	-0406	3/4	19	<b>TP090-0406</b>	1.18	30	2.24	57								
8	5/16	3/8	-0506	3/4	19	<b>TP090-0506</b>	1.18	30	2.24	57	<b>TP340N-0506</b>	0.91	23	1.97	50	1.77	45	
10	3/8	1/4	-0604	9/16		<b>TP090-0604</b>	1.10	28	2.17	55								
10	3/8	3/8	-0606	3/4	19	<b>TP090-0606</b>	1.18	30	2.24	57	<b>TP340N-0606</b>	0.91	23	1.97	50	1.77	45	
10	3/8	1/2	-0608	7/8	22	<b>TP090-0608</b>	1.38	35	2.48	63								
12	1/2	3/8	-0806	3/4	19	<b>TP090-0806</b>	1.18	30	2.36	60								
12	1/2	1/2	-0808	7/8	22	<b>TP090-0808</b>	1.38	35	2.60	66	<b>TP340N-0808</b>	1.14	29	2.32	59	2.01	51	
19	3/4	3/4	-1212	1.1/16	27	<b>TP090-1212</b>	1.50	38	2.91	74								
25	1	1	-1616	1.3/8		<b>TP090-1616</b>	1.81	46	3.31	84								

**NOTE:** Hose Compatibility for the TP000 series can be found on page 303.

## TP000 SERIES ONE-PIECE CRIMP COUPLINGS

<b>NPSM</b>	<b>TP020N</b>
-------------	---------------

60° SEAT

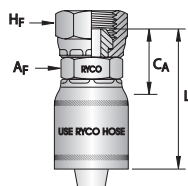

HOSE SIZE		THRD SIZE	DASH SIZE	BACK UP Af		FEMALE HEX		NPSM FEMALE					
DN	inch	inch		Af-SPANNER		Hf-SPANNER		PART NO		CA		L	
	inch	inch		inch	mm	inch	mm	inch	mm	inch	mm	inch	mm
6	1/4	1/4	-0404	1/2		11/16		<b>TP020N-0404</b>	0.94	24	1.97	50	

<b>JIC - MALE</b>	<b>TP030 - TP031</b>
-------------------	----------------------

37° FLARE

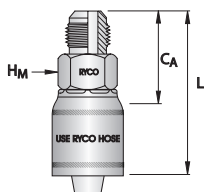

HOSE SIZE		THRD SIZE	DASH SIZE	MALE HEX		JIC MALE					
DN	inch	inch		Hm-SPANNER		PART NO		CA		L	
	inch	inch		inch	mm	inch	mm	inch	mm	inch	mm
5	3/16	7/16	-0307	1/2		<b>TP030-0307</b>	1.06	27	2.09	53	
						<b>TP031-0307</b>					
6	1/4	7/16	-0407	1/2		<b>TP030-0407</b>	1.06	27	2.13	54	
						<b>TP031-0407</b>					
6	1/4	1/2	-0408	9/16		<b>TP030-0408</b>	1.10	28	2.13	54	
						<b>TP031-0408</b>					
6	1/4	9/16	-0409	5/8	16	<b>TP030-0409</b>	1.10	28	2.17	55	
8	5/16	1/2	-0508	9/16		<b>TP030-0508</b>	1.10	28	2.13	54	
8	5/16	9/16	-0509	5/8	16	<b>TP030-0509</b>	1.10	28	2.17	55	
10	3/8	9/16	-0609	5/8	16	<b>TP030-0609</b>	1.10	28	2.17	55	
10	3/8	3/4	-0612	3/4	19	<b>TP030-0612</b>	1.26	32	2.32	59	
12	1/2	3/4	-0812	3/4	19	<b>TP030-0812</b>	1.26	32	2.44	62	
12	1/2	7/8	-0814	15/16	24	<b>TP030-0814</b>	1.42	36	2.64	67	
19	3/4	1.1/16	-1217	1.1/16	27	<b>TP030-1217</b>	1.57	40	3.03	77	
25	1	1.5/16	-1621	1.3/8	35	<b>TP030-1621</b>	1.77	45	3.27	83	
						<b>TP031-1621</b>					

**NOTE:** Hose Compatibility for the **TP000** series can be found on page 303.



# COUPLINGS

## TP000 SERIES ONE-PIECE CRIMP COUPLINGS

JSEAL™ / JIC

TP040 - TP041

CONVEX SEAT

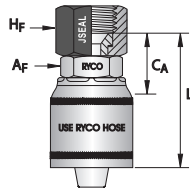

HOSE SIZE		THRD SIZE	TUBE SIZE	DASH SIZE	BACK UP AF		FEMALE HEX		JSEAL™ / JIC FEMALE				
DN	inch	inch	inch		AF-SPANNER		HF-SPANNER		PART NO	CA		L	
					inch	mm	inch	mm		inch	mm	inch	mm
5	3/16	7/16	1/4	-0307	1/2		9/16		<b>TP040-0307</b>	0.83	21	1.85	47
								14	<b>TP041-0307</b>				
5	3/16	1/2	5/16	-0308	1/2		5/8	16	<b>TP040-0308</b>	0.83	21	1.85	47
6	1/4	7/16	1/4	-0407	1/2		9/16		<b>TP040-0407</b>	0.87	22	1.89	48
								14	<b>TP041-0407</b>				
6	1/4	1/2	5/16	-0408	1/2		5/8	16	<b>TP040-0408</b>	0.87	22	1.89	48
6	1/4	9/16	3/8	-0409	9/16		11/16		<b>TP040-0409</b>	0.91	23	1.93	49
							3/4	19	<b>TP041-0409</b>				
8	5/16	9/16	3/8	-0509	9/16		11/16		<b>TP040-0509</b>	0.91	23	1.93	49
							3/4	19	<b>TP041-0509</b>				
10	3/8	7/16	1/4	-0607	1/2		9/16		<b>TP040-0607</b>	0.87	22	1.93	49
								14	<b>TP041-0607</b>				
10	3/8	9/16	3/8	-0609	9/16		11/16		<b>TP040-0609</b>	0.91	23	1.97	50
							3/4	19	<b>TP041-0609</b>				
10	3/8	3/4	1/2	-0612	11/16		7/8	22	<b>TP040-0612</b>	0.98	25	2.05	52
12	1/2	9/16	3/8	-0809	11/16		11/16		<b>TP040-0809</b>	0.91	23	2.09	53
							3/4	19	<b>TP041-0809</b>				
12	1/2	3/4	1/2	-0812	11/16		7/8	22	<b>TP040-0812</b>	0.94	24	2.17	55
12	1/2	7/8	5/8	-0814	13/16		1.1/16	27	<b>TP040-0814</b>	1.18	30	2.36	60
19	3/4	7/8	5/8	-1214	15/16	24	1.1/16	27	<b>TP040-1214</b>	1.22	31	2.68	68
19	3/4	1.1/16	3/4	-1217	1		1.1/4	32	<b>TP040-1217</b>	1.26	32	2.68	68
25	1	1.5/16	1	-1621	1.1/4	32	1.1/2	38	<b>TP040-1621</b>	1.42	36	2.91	74

<b>JSEAL™ / JIC</b>	<b>TP250 - TP251</b>	<b>TP240- TP241</b>
---------------------	----------------------	---------------------

**CONVEX SEAT**

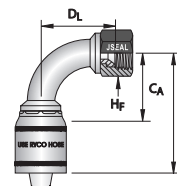
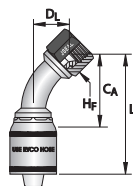

DN	HOSE SIZE		DASH SIZE	FEMALE HEX		JSEAL™ / JIC FEMALE 45° MEDIUM BEND						JSEAL™ / JIC FEMALE 90° MEDIUM BEND								
	inch	inch		inch	inch	mm	PART NO		CA	L	DL	inch	mm	PART NO		CA	L	DL	inch	mm
5	3/16	7/16	-0307	9/16										<b>TP240-0307</b>	1.02	26	2.09	53	1.26	32
6	1/4	7/16	-0407	9/16		<b>TP250-0407</b>	1.34	34	2.36	60	0.59	15	<b>TP240-0407</b>	1.02	26	2.09	53	1.26	32	
				14	<b>TP251-0407</b>	<b>TP241-0407</b>														
6	1/4	1/2	-0408	5/8	16								<b>TP240-0408</b>	1.02	26	2.09	53	1.26	32	
6	1/4	9/16	-0409	11/16		<b>TP250-0409</b>	1.34	34	2.36	60	0.59	15	<b>TP240-0409</b>	1.02	26	2.09	53	1.50	38	
				3/4	19	<b>TP251-0409</b>							<b>TP241-0409</b>							
8	5/16	9/16	-0509	11/16									<b>TP240-0509</b>	1.02	26	2.09	53	1.50	38	
				19				<b>TP241-0509</b>												
10	3/8	9/16	-0609	11/16		<b>TP250-0609</b>	1.50	38	2.56	65	0.55	14	<b>TP240-0609</b>	1.38	35	2.44	62	0.98	25	
				3/4	19	<b>TP251-0609</b>							<b>TP241-0609</b>							
10	3/8	3/4	-0612	7/8	22	<b>TP250-0612</b>	1.54	39	2.60	66	0.67	17	<b>TP240-0612</b>	1.38	35	2.44	62	1.18	30	
12	1/2	9/16	-0809	11/16									<b>TP240-0809</b>	1.38	35	2.56	65	0.98	25	
				3/4	19			<b>TP241-0809</b>												
12	1/2	3/4	-0812	7/8	22	<b>TP250-0812</b>	1.81	46	2.99	76	0.83	21	<b>TP240-0812</b>	1.57	40	2.76	70	1.61	41	
12	1/2	7/8	-0814	1.1/16	27	<b>TP250-0814</b>	1.85	47	3.11	79	0.87	22	<b>TP240-0814</b>	1.57	40	2.76	70	1.61	41	
19	3/4	1.1/16	-1217	1.1/4	32	<b>TP250-1217</b>	2.80	71	4.13	105	1.10	28	<b>TP240-1217</b>	2.20	56	3.54	90	2.24	57	
25	1	1.5/16	-1621	1.1/2	38								<b>TP240-1621</b>	2.68	68	4.09	104	2.83	72	

INTRODUCTION

HOSE

COUPLINGS

ADAPTORS

TECHNICAL

# COUPLINGS

## TP000 SERIES ONE-PIECE CRIMP COUPLINGS

JSEAL™ / JIC

TP280 - TP281

CONVEX SEAT

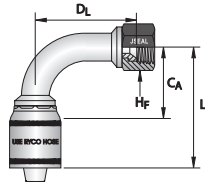

HOSE SIZE		THRD SIZE	DASH SIZE	FEMALE HEX		JSEAL™ / JIC FEMALE 90° LONG BEND						
DN	inch	inch		HF-SPANNER		PART NO	CA		L		DL	
				inch	mm		inch	mm	inch	mm	inch	mm
10	3/8	9/16	-0609	11/16		TP280-0609	2.05	52	3.11	79	2.17	55
				3/4	19	TP281-0609						
10	3/8	3/4	-0612	7/8	22	TP280-0612	2.32	59	3.39	86	2.52	64

METRIC - DKL

TP650

DKS  
METRIC (HEAVY)  
24° CONE

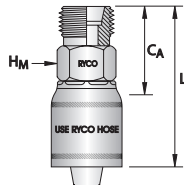

HOSE SIZE		THRD SIZE	DASH SIZE	MALE HEX		DKL MALE 24° CONE						
DN	inch	inch		HM-SPANNER		PART NO	CA		L			
				inch	mm		inch	mm	inch	mm		
6	1/4	12x1,5	-0412		14	TP650-0412	0.55	14	1.61	41		
6	1/4	14x1,5	-0414		17	TP650-0414	0.59	15	1.61	41		
6	1/4	16x1,5	-0416		17	TP650-0416	1.02	26	2.05	52		
8	5/16	16x1,5	-0516		17	TP650-0516	1.02	26	2.05	52		
8	5/16	18x1,5	-0518	3/4	19	TP650-0518	1.06	27	2.09	53		
10	3/8	16x1,5	-0616		17	TP650-0616	1.02	26	2.09	53		
10	3/8	18x1,5	-0618	3/4	19	TP650-0618	1.06	27	2.13	54		
10	3/8	22x1,5	-0622	15/16	24	TP650-0622	0.71	18	1.77	45		
12	1/2	22x1,5	-0822	15/16	24	TP650-0822	0.67	17	1.89	48		
12	1/2	26x1,5	-0826	1.1/16	27	TP650-0826	0.71	18	1.89	48		
19	3/4	30x2,0	-1230	1.1/4	32	TP650-1230	0.75	19	2.20	56		
25	1	36x2,0	-1636	1.5/8	41	TP650-1636	0.94	24	2.44	62		

**NOTE:** Hose Compatibility for the TP000 series can be found on page 303.

## TP000 SERIES ONE-PIECE CRIMP COUPLINGS

<b>METRIC - DKOL</b>	<b>TP501</b>	<b>TP510</b>
----------------------	--------------	--------------

**DKOL**  
24° CONE

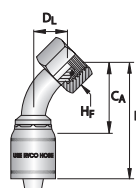
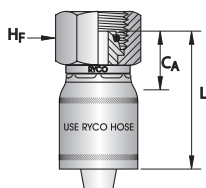

HOSE SIZE		THRD SIZE	DASH SIZE	FEMALE HEX	DKOL FEMALE 24° CONE					DKOL FEMALE 24° CONE 45° TUBE BEND							
DN	inch	inch		HF-SPANNER	PART NO	CA		L		PART NO	CA		L		DL		
				inch mm		inch mm	inch mm	inch mm			inch mm	inch mm	inch mm	inch mm	inch mm		
6	1/4	12	-0412		14	TP501-0412	0.87	22	1.89	48	TP510-0412	1.42	36	2.44	62	0.71	18
6	1/4	14	-0414		17	TP501-0414	0.87	22	1.93	49	TP510-0414	1.38	35	2.44	62	0.67	17
6	1/4	16	-0416	3/4	19	TP501-0416	0.94	24	1.97	50							
8	5/16	14	-0514		17	TP501-0514	0.87	22	1.93	49							
8	5/16	16	-0516	3/4	19	TP501-0516	1.02	26	2.09	53	TP510-0516	1.06	27	2.13	54	1.22	31
8	5/16	18	-0518	7/8	22	TP501-0518	1.02	26	2.05	52	TP510-0518	1.46	37	2.52	64	0.79	20
10	3/8	16	-0616	3/4	19	TP501-0616	0.91	23	1.97	50	TP510-0616	1.77	45	2.83	72	0.75	19
10	3/8	18	-0618	7/8	22	TP501-0618	0.94	24	2.01	51	TP510-0618	1.77	45	2.83	72	0.79	20
12	1/2	22	-0822	1.1/16	27	TP501-0822	0.98	25	2.20	56	TP510-0822	2.01	51	3.19	81	0.87	22
12	1/2	26	-0826	1.1/4	32	TP501-0826	1.10	28	2.28	58							
19	3/4	26	-1226	1.1/4	32	TP501-1226	1.18	30	2.52	64							
19	3/4	30	-1230		36	TP501-1230	1.14	29	2.44	62	TP510-1230	2.87	73	4.21	107	1.22	31
25	1	36	-1636	1.5/8	41	TP501-1636	1.34	34	2.83	72	TP510-1636	3.58	91	5.00	127	1.81	46

<b>METRIC - DKOL</b>	<b>TP520</b>
----------------------	--------------

**DKOL**  
METRIC O RING  
24° CONE

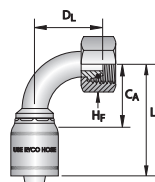

HOSE SIZE		THRD SIZE	DASH SIZE	FEMALE HEX	DKOL FEMALE 24° CONE 90° TUBE BEND							
DN	inch	inch		HF-SPANNER	PART NO	CA		L		DL		
				inch mm		inch mm	inch mm	inch mm	inch mm	inch mm		
6	1/4	12	-0412		14	TP520-0412	1.06	27	2.20	56	1.22	31
6	1/4	14	-0414		17	TP520-0414	1.02	26	2.17	55	1.22	31
6	1/4	16	-0416	3/4	19	TP520-0416	1.06	27	2.20	56	1.22	31
8	5/16	16	-0516	3/4	19	TP520-0516	1.06	27	2.13	54	1.22	31
8	5/16	18	-0518	7/8	22	TP520-0518	1.06	27	2.13	54	1.42	36
10	3/8	16	-0616	3/4	19	TP520-0616	1.34	34	2.40	61	1.38	35
10	3/8	18	-0618	7/8	22	TP520-0618	1.42	36	2.48	63	1.38	35
12	1/2	22	-0822	1.1/16	27	TP520-0822	1.57	40	2.76	70	1.73	44
12	1/2	26	-0826	1.1/4	32	TP520-0826	1.57	40	2.76	70	1.89	48
16	5/8	26	-1026	1.1/4	32	TP520-1026						
19	3/4	30	-1230		36	TP520-1230	2.20	56	3.54	90	2.56	65
25	1	36	-1636	1.5/8	41	TP520-1636	2.72	69	4.13	105	3.11	79

INTRODUCTION

HOSE

COUPLINGS

ADAPTORS

TECHNICAL

# COUPLINGS

## TP000 SERIES ONE-PIECE CRIMP COUPLINGS

### METRIC - DKS

### TP630

**DKS**  
**METRIC (HEAVY)**  
**24° CONE**

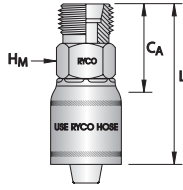

HOSE SIZE		THRD SIZE	DASH SIZE	MALE HEX		DKS MALE 24° CONE				
DN	inch	inch		HM-SPANNER		PART NO	C <sub>A</sub>		L	
				inch	mm		inch	mm	inch	mm
6	1/4	16X1,5	-0416		17	<b>TP630-0416</b>	1.06	27	2.09	53
6	1/4	18X1,5	-0418	3/4	19	<b>TP630-0418</b>	1.10	28	2.13	54
8	5/16	20X1,5	-0520	7/8	22	<b>TP630-0520</b>	1.10	28	2.17	55
10	3/8	20X1,5	-0620	7/8	22	<b>TP630-0620</b>	1.10	28	2.17	55
10	3/8	22X1,5	-0622	15/16	24	<b>TP630-0622</b>	1.26	32	2.32	59
12	1/2	24X1,5	-0824	1.1/16	27	<b>TP630-0824</b>	1.26	32	2.44	62
19	3/4	30X2,0	-1230	1.1/4	32	<b>TP630-1230</b>	1.38	35	2.83	72
19	3/4	36X2,0	-1236	1.5/8	41	<b>TP630-1236</b>	1.61	41	3.07	78
25	1	42X2,0	-1642		46	<b>TP630-1642</b>	1.81	46	3.27	83

### METRIC - DKOS

### TP711

**DKOS**  
**METRIC O RING**  
**24° CONE**

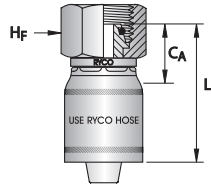

HOSE SIZE		THRD SIZE	DASH SIZE	FEMALE HEX		DKOS FEMALE 24° CONE				
DN	inch	inch		HF-SPANNER		PART NO	C <sub>A</sub>		L	
				inch	mm		inch	mm	inch	mm
6	1/4	14	-0414		17	<b>TP711-0414</b>	0.79	20	1.93	49
6	1/4	16	-0416	3/4	19	<b>TP711-0416</b>	0.91	23	2.09	53
6	1/4	18	-0418	7/8	22	<b>TP711-0418</b>	0.98	25	2.13	54
8	5/16	18	-0518	7/8	22	<b>TP711-0518</b>	1.06	27	2.13	54
8	5/16	20	-0520	15/16	24	<b>TP711-0520</b>	1.06	27	2.13	54
10	3/8	20	-0620	15/16	24	<b>TP711-0620</b>	1.06	27	2.13	54
10	3/8	22	-0622	1.1/16	27	<b>TP711-0622</b>	1.14	29	2.20	56
10	3/8	24	-0624	1.3/16	30	<b>TP711-0624</b>	1.14	29	2.20	56
12	1/2	24	-0824	1.3/16	30	<b>TP711-0824</b>	1.10	28	2.32	59
19	3/4	30	-1230		36	<b>TP711-1230</b>	1.30	33	2.60	66
19	3/4	36	-1236		46	<b>TP711-1236</b>	1.42	36	2.76	70
25	1	42	-1642	2	50	<b>TP711-1642</b>	1.50	38	2.95	75

**NOTE:** Hose Compatibility for the **TP000** series can be found on page 303.

## TP000 SERIES ONE-PIECE CRIMP COUPLINGS

INTRODUCTION

HOSE

COUPLINGS

ADAPTORS

TECHNICAL

<b>METRIC - DKOS</b>	<b>TP720</b>	<b>TP730</b>
----------------------	--------------	--------------

**DKOS  
METRIC O RING  
24° CONE**

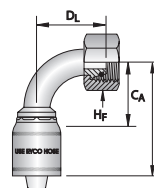
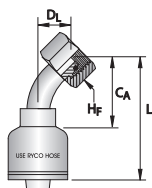

HOSE SIZE	THRD SIZE	DASH SIZE	FEMALE HEX		DKOS FEMALE 24° CONE 45° TUBE BEND							DKOS FEMALE 24° CONE 90° TUBE BEND							
					DN	inch	inch	HF-SPANNER	PART NO	CA	L	DL	PART NO	CA	L	DL			
			inch	mm	inch	mm	inch	mm	inch	mm	inch	mm	inch	mm	inch	mm	inch	mm	
6	1/4	14	-0414		17	<b>TP720-0414</b>	1.38	35	2.52	64	0.63	16	<b>TP730-0414</b>	1.06	27	2.20	56	1.10	28
6	1/4	16	-0416	3/4	19	<b>TP720-0416</b>	1.42	36	2.56	65	0.67	17	<b>TP730-0416</b>	1.06	27	2.20	56	1.22	31
6	1/4	18	-0418	7/8	22	<b>TP720-0418</b>	1.38	35	2.52	64	0.67	17	<b>TP730-0418</b>	1.06	27	2.20	56	1.14	29
8	5/16	18	-0518	7/8	22	<b>TP720-0518</b>	1.38	35	2.44	62	0.67	17							
8	5/16	20	-0520	15/16	24	<b>TP720-0520</b>	1.81	46	2.87	73	0.79	20	<b>TP730-0520</b>	1.42	36	2.48	63	1.42	36
10	3/8	20	-0620	15/16	24	<b>TP720-0620</b>	1.81	46	2.87	73	0.79	20	<b>TP730-0620</b>	1.42	36	2.48	63	1.42	36
10	3/8	22	-0622	1.1/16	27	<b>TP720-0622</b>	1.81	46	2.87	73	0.79	20	<b>TP730-0622</b>	1.42	36	2.48	63	1.42	36
12	1/2	24	-0824	1.3/16	30	<b>TP720-0824</b>	2.09	53	3.27	83	0.94	24	<b>TP730-0824</b>	1.57	40	2.76	70	1.89	48
19	3/4	30	-1230		36	<b>TP720-1230</b>	2.91	74	4.25	108	1.38	35	<b>TP730-1230</b>	2.13	54	3.43	87	2.68	68
19	3/4	36	-1236		46	<b>TP720-1236</b>	2.99	76	4.33	110	1.38	35	<b>TP730-1236</b>	2.17	55	3.50	89	2.68	68
25	1	42	-1642	2	50	<b>TP720-1642</b>	3.43	87	4.84	123	1.46	37	<b>TP730-1642</b>	2.72	69	4.13	105	3.03	77

<b>METRIC - BANJO</b>	<b>TP470</b>
-----------------------	--------------

**STRAIGHT**

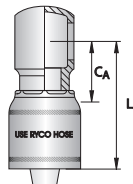

<b>METRIC BANJO BOLT</b>	<b>BBM</b>
--------------------------	------------

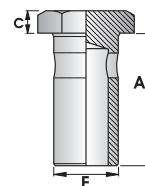

HOSE SIZE	THRD SIZE	DASH SIZE	METRIC BANJO					
			DN	inch	inch	PART NO	CA	L
			inch	mm	inch	mm	inch	mm
6	1/4	12x1,5	-0412	<b>TP470-0412</b>	0.91	23	1.97	50
6	1/4	14x1,5	-0414	<b>TP470-0414</b>	0.98	25	2.05	52
10	3/8	14x1,5	-0614	<b>TP470-0614</b>	1.06	27	2.17	55
10	3/8	18x1,5	-0618	<b>TP470-0618</b>	1.14	29	2.24	57
10	3/8	22x1,5	-0622	<b>TP470-0622</b>	1.38	35	2.44	62
12	1/2	18x1,5	-0818	<b>TP470-0818</b>	1.14	29	2.36	60
12	1/2	22x1,5	-0822	<b>TP470-0822</b>	1.26	32	2.48	63

THREAD SIZE E	DIMENSIONS (MM)			METRIC BANJO BOLT
	A	C	A/F	
mm				PART NO
M10x1,0	19	6	14	<b>BBM-10</b>
M12x1,5	24	6	17	<b>BBM-12</b>
M14x1,5	26	6	19	<b>BBM-14</b>
M16x1,5	28	6	22	<b>BBM-16</b>
M18x1,5	32	6	24	<b>BBM-18</b>
M20x1,5	37	7	27	<b>BBM-20</b>
M22x1,5	39	7	27	<b>BBM-22</b>
M26x1,5	45	7	32	<b>BBM-26</b>
M30x1,5	51	7	36	<b>BBM-30</b>
M36x2,0	71	12	46	<b>BBM-36</b>

**NOTE:** MBD Seals for BBM Banjo Bolts can be found on page 432.

**NOTE:** Hose Compatibility for the **TP000** series can be found on page 303.



# COUPLINGS

## TP000 SERIES ONE-PIECE CRIMP COUPLINGS

<b>STANDPIPE</b>	<b>TP640</b>	<b>TP643</b>
------------------	--------------	--------------

STANDPIPE

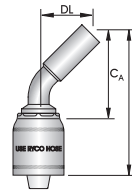
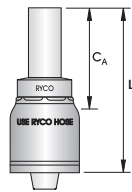

HOSE SIZE				THRD SIZE	DASH SIZE	STANDPIPE				STANDPIPE 45° BEND					
DN	inch	inch		PART NO	CA		L		PART NO	CA		L		DL	
					inch	mm	inch	mm		inch	mm	inch	mm	inch	mm
5	3/16	6	-0306	<b>TP640-0306</b>	1.22	31	2.20	56	<b>TP643-0306</b>	2.36	60	3.39	86	1.57	40
6	1/4	6	-0406	<b>TP640-0406</b>	1.22	31	2.28	58							
6	1/4	8	-0408	<b>TP640-0408</b>	1.22	31	2.28	58							
6	1/4	10	-0410	<b>TP640-0410</b>	1.34	34	2.40	61	<b>TP643-0410</b>	2.36	60	3.43	87	1.57	40
10	3/8	12	-0612	<b>TP640-0612</b>	1.34	34	2.44	62							
12	1/2	15	-0815	<b>TP640-0815</b>	1.34	34	2.52	64							
12	1/2	16	-0816	<b>TP640-0816</b>	1.54	39	2.72	69							

<b>STANDPIPE</b>	<b>TP646</b>
------------------	--------------

STANDPIPE

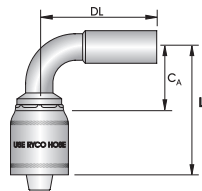

HOSE SIZE				THRD SIZE	DASH SIZE	STANDPIPE 90° BEND					
DN	inch	inch		PART NO	CA		L		DL		
					inch	mm	inch	mm	inch	mm	
5	3/16	6	-0306	<b>TP646-0306</b>	1.06	27	2.09	53	1.34	34	
6	1/4	10	-0410	<b>TP646-0410</b>	1.06	27	2.13	54	1.65	42	

**NOTE:** Hose Compatibility for the **TP000** series can be found on page 303.

## TP000 SERIES ONE-PIECE CRIMP COUPLINGS

<b>ORFS</b>	<b>TP800 - TP801</b>
-------------	----------------------

**O RING  
FACE SEAL**

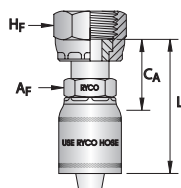

HOSE SIZE		THRD SIZE	DASH SIZE	BACK UP Af		FEMALE HEX		ORFS FEMALE				
DN	inch	inch		inch	mm	inch	mm	PART NO	CA		L	
									inch	mm	inch	mm
6	1/4	9/16	-0409	9/16	16	11/16	17	TP800-0409	1.18	30	2.24	57
								TP801-0409				
6	1/4	11/16	-0411	5/8	16	7/8	22	TP800-0411	1.30	33	2.36	60
								TP801-0411				
8	5/16	11/16	-0511	5/8	16	7/8	22	TP800-0511	1.30	33	2.36	60
								TP801-0511				
10	3/8	11/16	-0611	5/8	16	7/8	22	TP800-0611	1.30	33	2.36	60
10	3/8	13/16	-0613	3/4	19	15/16	24	TP800-0613	1.42	36	2.48	63
12	1/2	13/16	-0813	3/4	19	15/16	24	TP800-0813	1.42	36	2.60	66
19	3/4	1.3/16	-1219	1.1/8		1.3/8	36	TP800-1219	1.81	46	3.27	83
								TP801-1219				
19	3/4	1.7/16	-1223	1.3/8		1.5/8	41	TP800-1223	2.20	56	3.62	92
25	1	1.7/16	-1623	1.3/8		1.5/8	41	TP800-1623	2.24	57	3.70	94

<b>ORFS</b>	<b>TP810 - TP811</b>	<b>TP820 - TP821</b>
-------------	----------------------	----------------------

**O RING  
FACE SEAL**

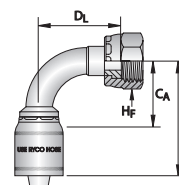
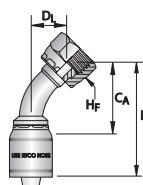

HOSE SIZE		THRD SIZE	DASH SIZE	FEMALE HEX		ORFS FEMALE 45° TUBE BEND					ORFS FEMALE 90° MEDIUM BEND										
DN	inch	inch		HF-SPANNER		PART NO		CA		L		DL		PART NO		CA		L		DL	
				inch	mm	inch	mm	inch	mm	inch	mm	inch	mm	inch	mm	inch	mm	inch	mm	inch	mm
6	1/4	9/16	-0409	11/16	16	TP810-0409	1.57	40	2.60	66	0.71	18	TP820-0409	1.14	29	2.17	55	1.26	32		
						TP811-0409				TP821-0409											
6	1/4	11/16	-0411	7/8	22	TP810-0411	1.57	40	2.60	66	0.71	18	TP820-0411	1.30	33	2.32	59	1.50	38		
8	5/16	11/16	-0511		22								TP820-0511	1.30	33	2.32	59	1.50	38		
10	3/8	11/16	-0611	7/8	22	TP810-0611	1.77	45	2.83	72	0.79	20	TP820-0611	1.34	34	2.40	61	1.50	38		
10	3/8	13/16	-0613	15/16	24	TP810-0613	1.57	40	2.64	67	0.67	17	TP820-0613	1.30	33	2.36	60	1.34	34		
12	1/2	13/16	-0813	15/16	24	TP810-0813	1.89	48	3.07	78	0.75	19	TP820-0813	1.50	38	2.68	68	1.61	41		
19	3/4	1.3/16	-1219	1.3/8	36	TP810-1219	2.52	64	3.86	98	1.14	29	TP820-1219	2.13	54	3.46	88	2.32	59		
						TP811-1219				TP821-1219											
25	1	1.7/16	-1623	1.5/8	41								TP820-1623	2.72	69	4.13	105	2.80	71		

**NOTE:** Hose Compatibility for the **TP000** series can be found on page 303.

INTRODUCTION

HOSE

COUPLINGS

ADAPTORS

TECHNICAL

# COUPLINGS

## TP000 SERIES ONE-PIECE CRIMP COUPLINGS

SAE	TP540	TP570
-----	-------	-------

45° FLARE

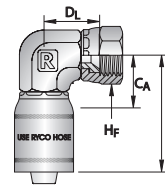
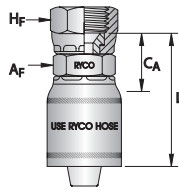

HOSE SIZE		THRD SIZE	DASH SIZE	BACK UP Af		FEMALE HEX		SAE FEMALE				SAE FEMALE 90° ELBOW										
DN	inch	inch		Af-SPANNER		Hf-SPANNER		PART NO		CA		L		PART NO		CA		L		DL		
				inch	mm	inch	mm			inch	mm	inch	mm			inch	mm	inch	mm	inch	mm	
6	1/4	5/8	-0410	5/8	16	3/4	19	<b>TP540-0410</b>	0.91	23	1.93	49										
8	5/16	5/8	-0510	5/8	16	3/4	19	<b>TP540-0510</b>	0.91	23	1.93	49										
10	3/8	5/8	-0610	5/8	16	3/4	19	<b>TP540-0610</b>	0.91	23	1.97	50	<b>TP570-0610</b>	0.71	18	1.77	45	0.91	23			

**NOTE:** Hose Compatibility for the TP000 series can be found on page 303.

## TT000 ONE-PIECE CRIMP COUPLINGS

### HOSE COMPATIBILITY FOR TT000 SERIES

For RYCO Hose Series RTH1 (all sizes).

SKIVE

INTRODUCTION

HOSE

COUPLINGS

ADAPTORS

TECHNICAL

### BSPT

### TT010

### TT320

60° SEAT

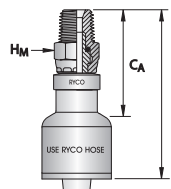
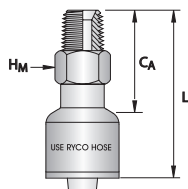

HOSE SIZE		THRD SIZE	DASH SIZE	MALE HEX	BSPT MALE				BSPT MALE SWIVEL						
DN	inch	inch		HM-SPANNER		PART NO	CA		L		PART NO	CA		L	
				inch	mm		inch	mm	inch	mm		inch	mm	inch	mm
6	1/4	1/4	-0404		14	<b>TT010-0404</b>	1.26	32	2.17	55					
10	3/8	1/4	-0604		14	<b>TT010-0604</b>	1.42	36	2.40	61					
10	3/8	3/8	-0606	3/4	19	<b>TT010-0606</b>	1.38	35	2.36	60					
10	3/8	1/2	-0608	7/8	22	<b>TT010-0608</b>	1.61	41	2.56	65					
12	1/2	3/8	-0806	3/4	19	<b>TT010-0806</b>	1.50	38	2.56	65					
12	1/2	1/2	-0808	7/8	22	<b>TT010-0808</b>	1.65	42	2.72	69	<b>TT320-0808</b>	2.01	51	3.11	79
19	3/4	3/4	-1212	1.1/16	27	<b>TT010-1212</b>	1.85	47	3.19	81					
25	1	1	-1616		36	<b>TT010-1616</b>	2.09	53	3.50	89					

**NOTE:** This "Live Swivel" TT320 Series Insert is for Maximum Working Pressure: 350 bar (5100 psi): -08 Thread Size. Its swivel capability is to allow easy installation and orientation and avoid twisting of hose. It is not designed for continuous rotation or continuous movement.

### BSPP

### TT020

60° SEAT

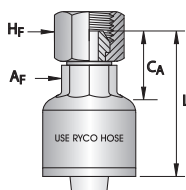

HOSE SIZE		THRD SIZE	DASH SIZE	BACK UP AF	FEMALE HEX	BSPP FEMALE						
DN	inch	inch		AF-SPANNER		HF-SPANNER		PART NO	CA		L	
				inch	mm	inch	mm		inch	mm	inch	mm
6	1/4	1/4	-0404		12	3/4	19	<b>TT020-0404</b>	0.91	23	1.77	45
10	3/8	3/8	-0606	9/16		7/8	22	<b>TT020-0606</b>	1.02	26	2.01	51
12	1/2	1/2	-0808	5/8	16	1.1/16	27	<b>TT020-0808</b>	1.10	28	2.17	55
16	5/8	1/2	-1008	13/16		1.1/16	27	<b>TT020-1008</b>	1.18	30	2.56	65
19	3/4	3/4	-1212	15/16	24	1.1/4	32	<b>TT020-1212</b>	1.30	33	2.60	66
25	1	1	-1616	1.1/4	32	1.1/2	38	<b>TT020-1616</b>	1.50	38	2.91	74

**NOTE:** Hose Compatibility for the TT000 series can be found on page 317.

# COUPLINGS

## TT000 ONE-PIECE CRIMP COUPLINGS

<b>BSPP</b>	<b>TT050</b>	<b>TT260</b>
-------------	--------------	--------------

60° SEAT

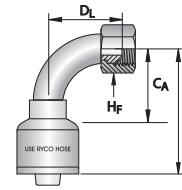
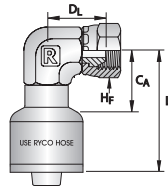

HOSE SIZE		THRD SIZE	DASH SIZE	FEMALE HEX	BSPP FEMALE 90° ELBOW						BSPP FEMALE 90° BEND								
DN	inch	inch		HF-SPANNER		PART NO	CA		L		DL		PART NO	CA		L		DL	
				inch	mm		inch	mm	inch	mm	inch	mm		inch	mm	inch	mm	inch	mm
6	1/4	1/4	-0404	3/4	19								<b>TT260-0404</b>	1.26	32	2.17	55	1.14	29
10	3/8	3/8	-0606	7/8	22								<b>TT260-0606</b>	1.38	35	2.32	59	1.30	33
12	1/2	1/2	-0808	1.1/16	27	<b>TT050-0808</b>	1.46	37	2.56	65	1.22	31	<b>TT260-0808</b>	1.61	41	2.68	68	1.77	45
19	3/4	3/4	-1212	1.1/4	32								<b>TT260-1212</b>	2.32	59	3.62	92	2.32	59
25	1	1	-1616	1.1/2	38								<b>TT260-1616</b>	2.68	68	4.09	104	3.07	78

<b>JIC - MALE</b>	<b>TT030 - TT031</b>
-------------------	----------------------

37° FLARE

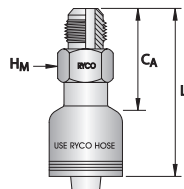

HOSE SIZE		THRD SIZE	DASH SIZE	MALE HEX	JIC MALE					
DN	inch	inch		HM-SPANNER		PART NO	CA		L	
				inch	mm		inch	mm	inch	mm
6	1/4	7/16	-0407	1/2		<b>TT030-0407</b>	1.26	32	2.17	55
					12	<b>TT031-0407</b>				
6	1/4	1/2	-0408		14	<b>TT030-0408</b>	1.22	31	2.13	54
6	1/4	9/16	-0409	5/8	16	<b>TT030-0409</b>	1.26	32	2.17	55
10	3/8	9/16	-0609	5/8	16	<b>TT030-0609</b>	1.42	36	2.36	60
10	3/8	3/4	-0612	3/4	19	<b>TT030-0612</b>	1.46	37	2.44	62
12	1/2	3/4	-0812	3/4	19	<b>TT030-0812</b>	1.57	40	2.64	67
12	1/2	7/8	-0814	15/16	24	<b>TT030-0814</b>	1.69	43	2.76	70

**NOTE:** Hose Compatibility for the **TT000** series can be found on page 317.

# TT000 ONE-PIECE CRIMP COUPLINGS

## JSEAL™ / JIC TT040 - TT041

CONVEX SEAT

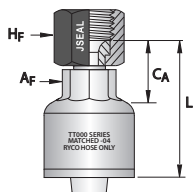

HOSE SIZE		THRD SIZE	DASH SIZE	BACK UP AF		FEMALE HEX		JSEAL™/ JIC FEMALE					
DN	inch	inch		Af-SPANNER		Hf-SPANNER		PART NO	CA		L		
				inch	mm	inch	mm		inch	mm	inch	mm	
6	1/4	7/16	-0407	1/2		9/16		<b>TT040-0407</b>	0.75	19	1.61	41	
					12		14	<b>TT041-0407</b>					
6	1/4	1/2	-0408	1/2		5/8	16	<b>TT040-0408</b>	0.83	21	1.73	44	
6	1/4	9/16	-0409	1/2		11/16		<b>TT040-0409</b>	0.87	22	1.77	45	
					12	3/4	19	<b>TT041-0409</b>					
10	3/8	9/16	-0609	9/16		11/16		<b>TT040-0609</b>	0.87	22	1.81	46	
				9/16		3/4	19	<b>TT041-0609</b>					
10	3/8	3/4	-0612	9/16		7/8	22	<b>TT040-0612</b>	1.02	26	1.97	50	
12	1/2	3/4	-0812	5/8	16	7/8	22	<b>TT040-0812</b>	0.94	24	2.01	51	
12	1/2	7/8	-0814	5/8	16	1.1/16	27	<b>TT040-0814</b>	1.06	27	2.13	54	
16	5/8	7/8	-1014	13/16		1.1/16	27	<b>TT040-1014</b>	1.06	27	2.40	61	
16	5/8	1.1/16	-1017	13/16		1.1/4	32	<b>TT040-1017</b>	1.18	30	2.56	65	
19	3/4	7/8	-1214	15/16	24	1.1/16	27	<b>TT040-1214</b>	1.34	34	2.64	67	
19	3/4	1.1/16	-1217	15/16	24	1.1/4	32	<b>TT040-1217</b>	1.22	31	2.52	64	
25	1	1.5/16	-1621	1.1/4	32	1.1/2	38	<b>TT040-1621</b>	1.38	35	2.80	71	

## JSEAL™ / JIC TT250 - TT251 TT240 - TT241

CONVEX SEAT

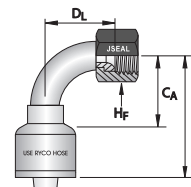
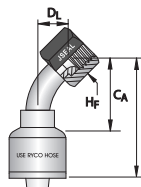

HOSE SIZE		THRD SIZE	DASH SIZE	FEMALE HEX		JSEAL™/ JIC FEMALE 45° BEND						JSEAL™/ JIC FEMALE 90° BEND									
DN	inch	inch		Hf-SPANNER		PART NO		CA		L		DL		PART NO		CA		L		DL	
				inch	mm			inch	mm	inch	mm	inch	mm			inch	mm	inch	mm	inch	mm
6	1/4	7/16	-0407	9/16											<b>TT240-0407</b>	1.54	39	2.44	62	1.26	32
					14										<b>TT241-0407</b>						
6	1/4	1/2	-0408	5/8	16										<b>TT240-0408</b>	1.26	32	2.17	55	1.26	32
6	1/4	9/16	-0409	11/16											<b>TT240-0409</b>	1.30	33	2.20	56	1.50	38
				3/4	19										<b>TT241-0409</b>						
10	3/8	9/16	-0609	11/16		<b>TT250-0609</b>	1.50	38	2.48	63	0.55	14			<b>TT240-0609</b>	1.34	34	2.32	59	1.02	26
				3/4	19	<b>TT251-0609</b>									<b>TT241-0609</b>						
10	3/8	3/4	-0612	7/8	22										<b>TT240-0612</b>	1.38	35	2.36	60	1.18	30
12	1/2	3/4	-0812	7/8	22										<b>TT240-0812</b>	1.61	41	2.68	68	1.50	38
12	1/2	7/8	-0814	1.1/16	27	<b>TT250-0814</b>	1.85	47	2.91	74	0.87	22			<b>TT240-0814</b>	1.61	41	2.68	68	1.61	41
16	5/8	7/8	-1014	1.1/16	27										<b>TT240-1014</b>	1.77	45	3.11	79	1.85	47
19	3/4	1.1/16	-1217	1.1/4	32										<b>TT240-1217</b>	2.32	59	3.62	92	2.24	57
25	1	1.5/16	-1621	1.1/2	38										<b>TT240-1621</b>	2.68	68	4.09	104	2.83	72

INTRODUCTION

HOSE

COUPLINGS

ADAPTORS

TECHNICAL



# COUPLINGS

## TT000 ONE-PIECE CRIMP COUPLINGS

<b>NPT</b>	<b>TT090</b>
------------	--------------

60° SEAT

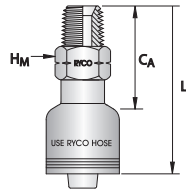

HOSE SIZE		THRD SIZE	DASH SIZE	MALE HEX		NPT MALE					
DN	inch	inch		HM-SPANNER		PART NO		CA		L	
				inch	mm			inch	mm	inch	mm
6	1/4	1/4	-0404	9/16		<b>TT090-0404</b>		1.26	32	2.17	55
10	3/8	3/8	-0606	3/4	19	<b>TT090-0606</b>		1.38	35	2.36	60
12	1/2	1/2	-0808	7/8	22	<b>TT090-0808</b>		1.65	42	2.72	69
19	3/4	3/4	-1212	1.1/16	27	<b>TT090-1212</b>		1.85	47	3.19	81
25	1	1	-1616	1.3/8		<b>TT090-1616</b>		2.09	53	3.50	89

<b>METRIC - DKL</b>	<b>TT600</b>	<b>TT670</b>
---------------------	--------------	--------------

DKL 24°/60° CONE

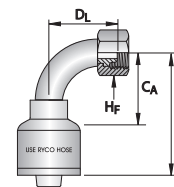
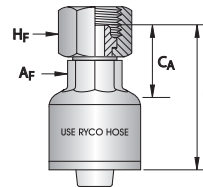

HOSE SIZE		THRD SIZE	DASH SIZE	BACK UP AF		FEMALE HEX		DKL FEMALE 24°/60° CONE				DKL FEMALE 24°/60° CONE 90° TUBE BEND									
DN	inch	inch		AF-SPANNER		HF-SPANNER		PART NO		CA		L		PART NO		CA		L		DL	
				inch	mm	inch	mm			inch	mm	inch	mm			inch	mm	inch	mm	inch	mm
6	1/4	14	-0414	12		17		<b>TT600-0414</b>	1.06	27	1.97	50	<b>TT670-0414</b>	1.06	27	1.97	50	1.22	31		
12	1/2	22	-0822	5/8	16	1.1/16	27	<b>TT600-0822</b>	1.22	31	2.28	58	<b>TT670-0822</b>	1.57	40	2.64	67	1.73	44		

<b>SAE</b>	<b>TT540</b>
------------	--------------

45° FLARE

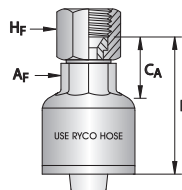

HOSE SIZE		THRD SIZE	TUBE SIZE	DASH SIZE	BACK UP AF		FEMALE HEX		SAE FEMALE					
DN	inch	inch	inch		AF-SPANNER		HF-SPANNER		PART NO		CA		L	
					inch	mm	inch	mm			inch	mm	inch	mm
6	1/4	7/16	1/4	-0407	1/2		9/16		<b>TT540-0407</b>	1.02	26	1.93	49	
6	1/4	1/2	5/16	-0408	1/2		5/8	16	<b>TT540-0408</b>	1.02	26	1.93	49	
10	3/8	5/8	3/8	-0610	9/16		3/4	19	<b>TT540-0610</b>	1.22	31	2.17	55	
10	3/8	3/4	1/2	-0612	9/16		7/8	22	<b>TT540-0612</b>	1.02	26	1.97	50	
12	1/2	3/4	1/2	-0812	5/8	16	7/8	22	<b>TT540-0812</b>	1.30	33	2.36	60	
12	1/2	7/8	5/8	-0814	5/8	16	1.1/16	27	<b>TT540-0814</b>	1.30	33	2.40	61	
16	5/8	7/8	5/8	-1014	13/16		1.1/16	27	<b>TT540-1014</b>	1.06	27	2.40	61	
16	5/8	1.1/16	3/4	-1017	13/16		1.1/4	32	<b>TT540-1017</b>	1.18	30	2.56	65	
19	3/4	7/8	5/8	-1214	15/16	24	1.1/16	27	<b>TT540-1214</b>	1.34	34	2.64	67	
19	3/4	1.1/16	3/4	-1217	15/16	24	1.1/4	32	<b>TT540-1217</b>	1.22	31	2.52	64	

## TG000 ONE-PIECE CRIMP COUPLINGS

### HOSE COMPATIBILITY FOR TG000 SERIES

For RYCO Hose Series TPGL.

INTRODUCTION

HOSE

COUPLINGS

ADAPTORS

TECHNICAL

#### BSPT

#### TG010

#### TG320

60° SEAT



HOSE SIZE		THRD SIZE	TUBE SIZE	DASH SIZE	MALE HEX		BSPT MALE				BSPT MALE SWIVEL							
DN	inch	inch	inch		HM-SPANNER		PART NO		CA		L		PART NO		CA		L	
					inch	mm			inch	mm	inch	mm			inch	mm	inch	mm
4	1/8	1/8	1/8	-0202		12	<b>TG010-0202</b>	1.02	26	1.93	49	<b>TG320-0202</b>	0.91	23	1.81	46		

**NOTE:** This "Live Swivel" **TG320** Series Insert is for Maximum Working Pressure: 420 bar (6100 psi): -02 Thread Size. Its swivel capability is to allow easy installation and orientation and avoid twisting of hose. It is not designed for continuous rotation or continuous movement.

#### BSPP

#### TG020

60° SEAT

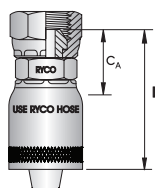

HOSE SIZE		THRD SIZE	DASH SIZE	MALE HEX		FEMALE HEX		BSPP FEMALE					
DN	inch	inch		HM-SPANNER		HF-SPANNER		PART NO		CA		L	
				inch	mm	inch	mm			inch	mm	inch	mm
4	1/8	1/8	-0202		12		14	<b>TG020-0202</b>	0.94	24	1.85	47	

#### NPT

#### TG090

#### TG320N

60° SEAT

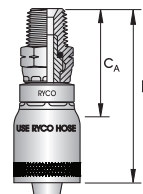
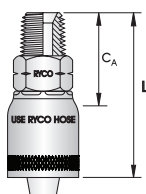

HOSE SIZE		THRD SIZE	TUBE SIZE	DASH SIZE	MALE HEX		NPT MALE				NPT MALE SWIVEL							
DN	inch	inch	inch		HM-SPANNER		PART NO		CA		L		PART NO		CA		L	
					inch	mm			inch	mm	inch	mm			inch	mm	inch	mm
4	1/8	1/8	1/8	-0202		12	<b>TG090-0202</b>	1.02	26	1.93	49	<b>TG320N-0202</b>	0.91	23	1.81	46		

**NOTE:** This "Live Swivel" **TG320N** Series Insert is for Maximum Working Pressure: 420 bar (6100 psi): -02 Thread Size. Its swivel capability is to allow easy installation and orientation and avoid twisting of hose. It is not designed for continuous rotation or continuous movement.

**NOTE:** Hose Compatibility for the **TG000** series can be found on page 321.

# COUPLINGS

## TG000 ONE-PIECE CRIMP COUPLINGS

<b>NPSM</b>	<b>TG020N</b>
-------------	---------------

60° SEAT

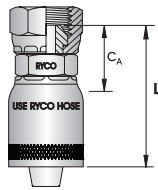

HOSE SIZE				THRD SIZE	TUBE SIZE	DASH SIZE	MALE HEX		FEMALE HEX		NPSM FEMALE			
DN	inch	inch	inch		HM-SPANNER		HF-SPANNER		PART NO		CA		L	
					inch	mm	inch	mm			inch	mm	inch	mm
4	1/8	1/8	1/8	-0202	7/16	11	9/16		<b>TG020N-0202</b>	0.98	25	1.89	48	

<b>JIC - MALE</b>	<b>TG030</b>
-------------------	--------------

37° FLARE

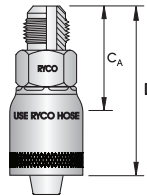

HOSE SIZE				THRD SIZE	TUBE SIZE	DASH SIZE	MALE HEX	JIC MALE						
DN	inch	inch	inch		HM-SPANNER			PART NO		CA		L		
					inch	mm				inch	mm	inch	mm	
4	1/8	7/16	1/4	-0207	1/2			<b>TG030-0207</b>	1.10	28	2.01	51		

<b>JSEAL™ / JIC</b>	<b>TG040</b>
---------------------	--------------

CONVEX SEAT

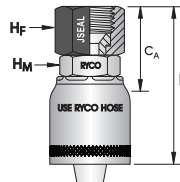

HOSE SIZE				THRD SIZE	DASH SIZE	MALE HEX	FEMALE HEX	JSEAL™ / JIC FEMALE						
DN	inch	inch			HM-SPANNER		HF-SPANNER		PART NO		CA		L	
					inch	mm	inch	mm			inch	mm	inch	mm
4	1/8	7/16	-0207	7/16	11	9/16			<b>TG040-0207</b>	0.87	22	1.77	45	

<b>STANDPIPE</b>	<b>TG640</b>
------------------	--------------

METRIC

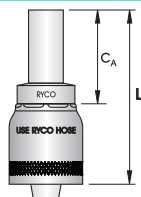

HOSE SIZE				TUBE SIZE	DASH SIZE	METRIC STANDPIPE							
DN	inch	mm			PART NO		CA		L				
					inch	mm	inch	mm	inch	mm			
4	1/8	6	-0206		<b>TG640-0206</b>	1.22	31	2.13	54				
4	1/8	8	-0208		<b>TG640-0208</b>	1.22	31	2.13	54				

## TW4000 ONE-PIECE CRIMP COUPLINGS

### HOSE COMPATIBILITY FOR TW4000 SERIES

For RYCO Hose Series SHOCKWAVE.

#### BSP0

#### TW4027

60° SEAT  
O RING

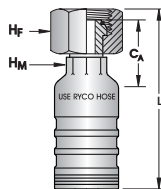

HOSE SIZE		THRD SIZE	TUBE SIZE	DASH SIZE	MALE HEX	FEMALE HEX	BSP0 FEMALE O RING						
DN	inch	inch	inch		HM-SPANNER inch mm	Hf-SPANNER inch mm	PART NO	CA		L			
								inch	mm	inch	mm		
10	3/8	3/8	3/8	-0606	11/16	7/8	22	<b>TW4027-0606</b>	1.10	28	3.07	78	
12	1/2	1/2	1/2	-0808	11/16	1.1/16	27	<b>TW4027-0808</b>	1.14	29	3.31	84	
19	3/4	3/4	3/4	-1212	1.1/16	27	1.1/4	32	<b>TW4027-1212</b>	1.26	32	3.58	91
25	1	1	1	-1616	1.1/4	32	1.1/2	38	<b>TW4027-1616</b>	1.50	38	3.74	95

#### NPT

#### TW4090

NPT MALE  
60° SEAT

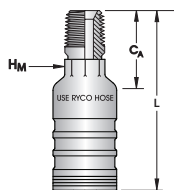

HOSE SIZE		THRD SIZE	TUBE SIZE	DASH SIZE	MALE HEX	NPT MALE					
DN	inch	inch	inch		HM-SPANNER inch mm	PART NO	CA		L		
							inch	mm	inch	mm	
10	3/8	3/8	3/8	-0606	11/16	<b>TW4090-0606</b>	1.61	41	3.58	91	
12	1/2	1/2	1/2	-0808	7/8	22	<b>TW4090-0808</b>	1.85	47	4.02	102
19	3/4	3/4	3/4	-1212	1.1/16	27	<b>TW4090-1212</b>	2.01	51	4.29	109
25	1	1	1	-1616	1.3/8		<b>TW4090-1616</b>	2.32	59	4.57	116

#### METRIC - DKOS

#### TW4711

DKOS  
METRIC O RING (HEAVY)  
24° CONE

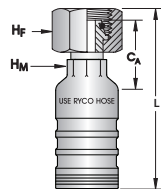

HOSE SIZE		THRD SIZE	TUBE SIZE	DASH SIZE	MALE HEX	FEMALE HEX	DKOS FEMALE 24° CONE						
DN	inch	inch	inch		HM-SPANNER inch mm	Hf-SPANNER inch mm	PART NO	CA		L			
								inch	mm	inch	mm		
10	3/8	22	14	-0622	11/16	1.1/16	27	<b>TW4711-0622</b>	1.34	34	3.35	85	
10	3/8	24	16	-0624	11/16	1.1/4	32	<b>TW4711-0624</b>	1.38	35	3.35	85	
12	1/2	24	16	-0824	11/16	1.1/4	32	<b>TW4711-0824</b>	1.42	36	3.58	91	
19	3/4	36	25	-1236	1.1/16	27	46	<b>TW4711-1236</b>	1.77	45	4.06	103	
25	1	42	30	-1642	1.1/4	32	2	50	<b>TW4711-1642</b>	1.89	48	4.13	105

**NOTE:** Hose Compatibility for the TW4000 series can be found on 323.

# COUPLINGS

## 8000 SERIES PUSH-ON COUPLINGS

### HOSE COMPATIBILITY FOR 8000 SERIES

For RYCO Hose Series PL1, PL1D and RQP6 all sizes.

**BSPP**

**8111**

**60° SEAT  
O RING & RETAINING  
RING SUPPLIED**

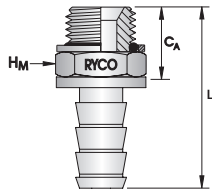

HOSE SIZE		THREAD SIZE	DASH SIZE	MALE HEX		BSPP O RING MALE				
DN	inch	inch		HM-SPANNER		PART NO	C <sub>A</sub>		L	
				inch	mm		inch	mm	inch	mm
16	5/8	1/2	-1008	7/8	22	<b>8111-1008</b>	0.94	24	1.93	49

**BSPP**

**8020**

**60° SEAT**

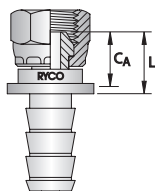

HOSE SIZE		THREAD SIZE	DASH SIZE	FEMALE HEX		BSPP FEMALE				
DN	inch	inch		HF-SPANNER		PART NO	C <sub>A</sub>		L	
				inch	mm		inch	mm	inch	mm
6	1/4	1/8	-0402		14	<b>8020-0402</b>	0.59	15	1.34	34
6	1/4	1/4	-0404	3/4	19	<b>8020-0404</b>	0.59	15	1.38	35
6	1/4	3/8	-0406	7/8	22	<b>8020-0406</b>	0.67	17	1.46	37
8	5/16	1/8	-0502		14	<b>8020-0502</b>	0.59	15	1.34	34
8	5/16	1/4	-0504	3/4	19	<b>8020-0504</b>	0.59	15	1.38	35
10	3/8	3/8	-0606	7/8	22	<b>8020-0606</b>	0.67	17	1.54	39
10	3/8	1/2	-0608	1.1/16	27	<b>8020-0608</b>	0.75	19	1.61	41
12	1/2	1/2	-0808	1.1/16	27	<b>8020-0808</b>	0.75	19	1.73	44
16	5/8	1/2	-1008	1.1/16	27	<b>8020-1008</b>	0.75	19	1.73	44
19	3/4	3/4	-1212	1.1/4	32	<b>8020-1212</b>	0.75	19	2.17	55

**NOTE:** Hose Compatibility for the **8000** series can be found on page 324.

## 8000 SERIES PUSH-ON COUPLINGS

INTRODUCTION

HOSE

COUPLINGS

ADAPTORS

TECHNICAL

<b>BSPP</b>	<b>8060</b>	<b>8050</b>
-------------	-------------	-------------

60° SEAT

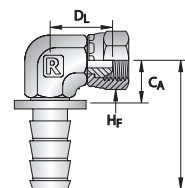
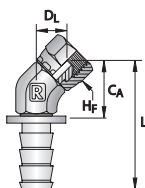

HOSE SIZE	THRD SIZE	DASH SIZE	FEMALE HEX	BSPP FEMALE 45° ELBOW						BSPP FEMALE 90° ELBOW											
				HF-SPANNER		PART NO	CA		L		DL		PART NO	CA		L		DL			
DN	inch	inch		inch	mm		inch	mm	inch	mm	inch	mm	inch	mm	inch	mm	inch	mm			
6	1/4	1/4	-0404	3/4	19										<b>8050-0404</b>	0.51	13	1.30	33	0.94	24
8	5/16	1/4	-0504	3/4	19										<b>8050-0504</b>	0.51	13	1.30	33	0.94	24
10	3/8	3/8	-0606	7/8	22										<b>8050-0606</b>	0.67	17	1.54	39	1.14	29
12	1/2	1/2	-0808	1.1/16	27										<b>8050-0808</b>	0.75	19	1.77	45	1.22	31
16	5/8	1/2	-1008	1.1/16	27										<b>8050-1008</b>	0.83	21	1.85	47	1.38	35
19	3/4	3/4	-1212	1.1/4	32	<b>8060-1212</b>	1.18	30	2.60	66	0.79	20	<b>8050-1212</b>	0.87	22	2.28	58	1.42	36		

<b>BSPT</b>	<b>8010</b>
-------------	-------------

60° SEAT

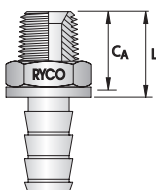

HOSE SIZE	THREAD SIZE	DASH SIZE	MALE HEX	BSPT MALE						
				HM-SPANNER		PART NO	CA		L	
DN	inch	inch		inch	mm		inch	mm	inch	mm
6	1/4	1/8	-0402		12	<b>8010-0402</b>	0.71	18	1.46	37
6	1/4	1/4	-0404		14	<b>8010-0404</b>	0.87	22	1.65	42
6	1/4	3/8	-0406	3/4	19	<b>8010-0406</b>	0.87	22	1.65	42
8	5/16	1/8	-0502		12	<b>8010-0502</b>	0.71	18	1.46	37
8	5/16	1/4	-0504		14	<b>8010-0504</b>	0.87	22	1.65	42
8	5/16	3/8	-0506	3/4	19	<b>8010-0506</b>	0.87	22	1.65	42
10	3/8	1/4	-0604		14	<b>8010-0604</b>	0.87	22	1.73	44
10	3/8	3/8	-0606	3/4	19	<b>8010-0606</b>	0.87	22	1.73	44
10	3/8	1/2	-0608	7/8	22	<b>8010-0608</b>	1.14	29	2.01	51
12	1/2	3/8	-0806	3/4	19	<b>8010-0806</b>	0.87	22	1.89	48
12	1/2	1/2	-0808	7/8	22	<b>8010-0808</b>	1.14	29	2.13	54
12	1/2	3/4	-0812	1.1/16	27	<b>8010-0812</b>	1.14	29	2.13	54
16	5/8	1/2	-1008	7/8	22	<b>8010-1008</b>	1.14	29	2.13	54
19	3/4	1/2	-1208	7/8	22	<b>8010-1208</b>	1.14	29	2.56	65
19	3/4	3/4	-1212	1.1/16	27	<b>8010-1212</b>	1.14	29	2.56	65

**NOTE:** Hose Compatibility for the **8000** series can be found on page 324.



# COUPLINGS

## 8000 SERIES PUSH-ON COUPLINGS

<b>NPT</b>	<b>8090</b>
------------	-------------

60° SEAT

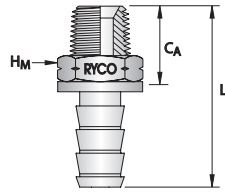

HOSE SIZE		THRD SIZE	DASH SIZE	MALE HEX		NPT MALE				
DN	inch	inch		HM-SPANNER		PART NO	CA		L	
	inch	inch		inch	mm		inch	mm	inch	mm
6	1/4	1/8	-0402	1/2		<b>8090-0402</b>	0.71	18	1.46	37
6	1/4	1/4	-0404	9/16		<b>8090-0404</b>	0.87	22	1.65	42
8	5/16	1/8	-0502	1/2		<b>8090-0502</b>	0.71	18	1.46	37
8	5/16	1/4	-0504	9/16		<b>8090-0504</b>	0.87	22	1.65	42
10	3/8	1/4	-0604	9/16		<b>8090-0604</b>	0.87	22	1.73	44
10	3/8	3/8	-0606	3/4	19	<b>8090-0606</b>	0.87	22	1.73	44
12	1/2	3/8	-0806	3/4	19	<b>8090-0806</b>	0.87	22	1.89	48
12	1/2	1/2	-0808	7/8	22	<b>8090-0808</b>	1.14	29	2.13	54
19	3/4	3/4	-1212	1.1/16	27	<b>8090-1212</b>	1.18	30	2.60	66

<b>JIC - MALE</b>	<b>8030</b>
-------------------	-------------

37° FLARE

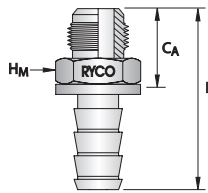

HOSE SIZE		THRD SIZE	TUBE SIZE	DASH SIZE	MALE HEX		JIC MALE				
DN	inch	inch	inch		HM-SPANNER		PART NO	CA		L	
	inch	inch	inch		inch	mm		inch	mm	inch	mm
6	1/4	7/16	1/4	-0407	1/2		<b>8030-0407</b>	0.87	22	1.61	41
6	1/4	1/2	5/16	-0408	1/2		<b>8030-0408</b>	0.87	22	1.61	41
8	5/16	1/2	5/16	-0508	1/2		<b>8030-0508</b>	0.87	22	1.61	41
10	3/8	9/16	3/8	-0609	5/8	16	<b>8030-0609</b>	0.87	22	1.73	44
10	3/8	3/4	1/2	-0612	3/4	19	<b>8030-0612</b>	0.94	24	1.81	46
12	1/2	3/4	1/2	-0812	3/4	19	<b>8030-0812</b>	0.94	24	1.97	50
12	1/2	7/8	5/8	-0814	15/16	24	<b>8030-0814</b>	1.10	28	2.13	54
16	5/8	7/8	5/8	-1014	15/16	24	<b>8030-1014</b>	1.10	28	2.13	54
19	3/4	1.1/16	3/4	-1217	1.1/16	27	<b>8030-1217</b>	1.22	31	2.64	67

**NOTE:** Hose Compatibility for the **8000** series can be found on page 324.

**JSEAL™ / JIC** **8040**

37° FLARE

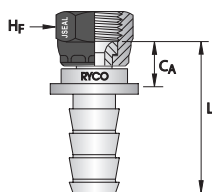

HOSE SIZE		THRD SIZE	DASH SIZE	FEMALE HEX	JSEAL™ / JIC FEMALE					
DN	inch	inch		HF-SPANNER		PART NO	CA		L	
				inch	mm		inch	mm	inch	mm
6	1/4	7/16	-0407	9/16		<b>8040-0407</b>	0.51	13	1.30	33
6	1/4	1/2	-0408	5/8	16	<b>8040-0408</b>	0.51	13	1.30	33
6	1/4	9/16	-0409	11/16		<b>8040-0409</b>	0.55	14	1.30	33
8	5/16	1/2	-0508	5/8	16	<b>8040-0508</b>	0.51	13	1.30	33
8	5/16	9/16	-0509	11/16		<b>8040-0509</b>	0.55	14	1.30	33
10	3/8	9/16	-0609	11/16		<b>8040-0609</b>	0.55	14	1.42	36
10	3/8	3/4	-0612	7/8	22	<b>8040-0612</b>	0.59	15	1.46	37
12	1/2	3/4	-0812	7/8	22	<b>8040-0812</b>	0.59	15	1.61	41
12	1/2	7/8	-0814	1.1/16	27	<b>8040-0814</b>	0.75	19	1.73	44
16	5/8	7/8	-1014	1.1/16	27	<b>8040-1014</b>	0.75	19	1.73	44
19	3/4	1.1/16	-1217	1.1/4	32	<b>8040-1217</b>	0.79	20	2.20	56

**JSEAL™ / JIC** **8070** **8240**

CONVEX SEAT

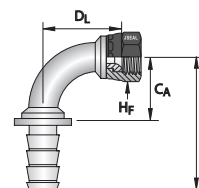
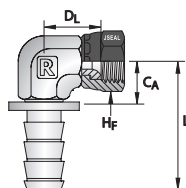

HOSE SIZE		THRD SIZE	DASH SIZE	FEMALE HEX	JSEAL™ / JIC FEMALE 90° ELBOW						JSEAL™ / JIC FEMALE 90° TUBE BEND								
DN	inch	inch		HF-SPANNER		PART NO	CA		L		DL		PART NO	CA		L		DL	
				inch	mm		inch	mm	inch	mm	inch	mm		inch	mm	inch	mm	inch	mm
6	1/4	7/16	-0407	9/16		<b>8070-0407</b>	0.59	15	1.38	35	0.71	18							
6	1/4	1/2	-0408	5/8	16	<b>8070-0408</b>	0.51	13	1.30	33	0.67	17							
10	3/8	9/16	-0609	11/16		<b>8070-0609</b>	0.67	17	1.54	39	0.91	23	<b>8240-0609</b>	1.18	30	2.05	52	1.50	38
10	3/8	3/4	-0612	7/8	22	<b>8070-0612</b>	0.67	17	1.54	39	0.94	24							
12	1/2	3/4	-0812	7/8	22	<b>8070-0812</b>	0.75	19	1.77	45	1.06	27	<b>8240-0812</b>	1.50	38	2.52	64	1.61	41
12	1/2	7/8	-0814	1.1/16	27	<b>8070-0814</b>	0.75	19	1.77	45	1.22	31	<b>8240-1014</b>	1.69	43	2.72	69	1.89	48
19	3/4	1.1/16	-1217	1.1/4	32	<b>8070-1217</b>	0.87	22	2.28	58	1.26	32							

**NOTE:** Hose Compatibility for the **8000** series can be found on page 324.

# COUPLINGS

## 8000 SERIES PUSH-ON COUPLINGS

<b>JOINER</b>	<b>8900</b>
---------------	-------------

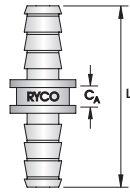

HOSE SIZE		DASH SIZE	SAE FEMALE 90° ELBOW	CA		L	
DN	inch	inch		inch	mm	inch	mm
6	1/4	-0404	<b>8900-0404</b>	0.31	8	1.89	48
8	5/16	-0505	<b>8900-0505</b>	0.31	8	1.89	48
10	3/8	-0606	<b>8900-0606</b>	0.31	8	2.09	53
12	1/2	-0808	<b>8900-0808</b>	0.35	9	2.40	61
16	5/8	-1010	<b>8900-1010</b>	0.20	5	2.24	57
19	3/4	-1212	<b>8900-1212</b>	0.35	9	3.23	82

<b>SAE</b>	<b>8530</b>
------------	-------------

45° FLARE

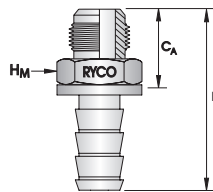

HOSE SIZE		THRD SIZE	TUBE SIZE	DASH SIZE	MALE HEX		SAE MALE				
DN	inch	inch	inch		HM-SPANNER		PART NO	CA		L	
					inch	mm		inch	mm	inch	mm
8	5/16	5/8	3/8	-0510	5/8	16	<b>8530-0510</b>	0.91	23	1.69	43
10	3/8	5/8	3/8	-0610	5/8	16	<b>8530-0610</b>	0.91	23	1.77	45
19	3/4	1.1/16	3/4	-1217	1.1/16	27	<b>8530-1217</b>	1.38	35	2.80	71

**NOTE:** Hose Compatibility for the **8000** series can be found on page 324.

## 8000 SERIES PUSH-ON COUPLINGS

<b>SAE</b>	<b>8540</b>	<b>8570</b>
------------	-------------	-------------

45° FLARE

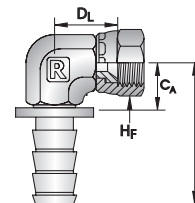
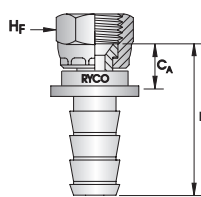

HOSE SIZE		THRD SIZE	TUBE SIZE	DASH SIZE	FEMALE HEX	SAE FEMALE				SAE FEMALE 90° ELBOW								
DN	inch	inch	inch		HF-SPANNER		PART NO	CA		L		PART NO	CA		L		DL	
					inch	mm		inch	mm	inch	mm		inch	mm	inch	mm	inch	mm
8	5/16	5/8	3/8	-0510	3/4	19	<b>8540-0510</b>	0.55	14	1.30	33							
10	3/8	5/8	3/8	-0610	3/4	19	<b>8540-0610</b>	0.55	14	1.42	36	<b>8570-0610</b>	0.67	17	1.54	39	0.91	23
16	5/8	1.1/16	3/4	-1017	1.1/4	32	<b>8540-1017</b>	0.67	17	1.69	43							
19	3/4	1.1/16	3/4	-1217	1.1/4	32	<b>8540-1217</b>	0.67	17	2.09	53							

<b>SAE</b>	<b>8740</b>
------------	-------------

INVERTED  
MALE FLARE  
BRASS

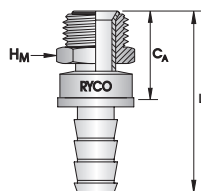

HOSE SIZE	THRD SIZE	TUBE SIZE	DASH SIZE	MALE HEX	SAE INVERTED MALE FLARE						
DN	inch	inch	inch		HM-SPANNER		PART NO	CA		L	
					inch	mm		inch	mm	inch	mm
6	1/4	7/16	1/4	-0407	7/16	11	<b>8740-0407</b>	0.87	22	1.65	42
6	1/4	1/2	5/16	-0408	1/2		<b>8740-0408</b>	0.94	24	1.73	44
8	5/16	1/2	5/16	-0508	1/2		<b>8740-0508</b>	0.94	24	1.73	44
8	5/16	5/8	3/8	-0510	5/8	16	<b>8740-0510</b>	1.06	27	1.85	47
10	3/8	5/8	3/8	-0610	5/8	16	<b>8740-0610</b>	1.06	27	1.93	49

**NOTE:** Hose Compatibility for the **8000** series can be found on page 324.

# COUPLINGS

## 8000 SERIES PUSH-ON COUPLINGS

**SALVAGE**

**8230**

**TUBE WELD**

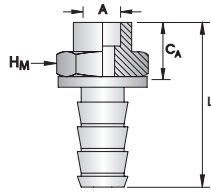

HOSE SIZE		A	DASH SIZE	MALE HEX		SALVAGE (LIFESAVER)				
DN	inch	inch		inch	mm	PART NO	CA		L	
							inch	mm	inch	mm
6	1/4	3/8	-0406	5/8	16	<b>8230-0406</b>	0.55	14	1.34	34
10	3/8	1/4	-0604	1/2		<b>8230-0604</b>	0.55	14	1.42	36
10	3/8	3/8	-0606	5/8	16	<b>8230-0606</b>	0.55	14	1.42	36
12	1/2	1/2	-0808	3/4	19	<b>8230-0808</b>	0.55	14	1.57	40
12	1/2	5/8	-0810	7/8	22	<b>8230-0810</b>	0.63	16	1.65	42
16	5/8	5/8	-1010	7/8	22	<b>8230-1010</b>	0.63	16	1.65	42
19	3/4	3/4	-1212	1.1/16	27	<b>8230-1212</b>	0.63	16	2.05	52

**STANDPIPE**

**8180**

**IMPERIAL**

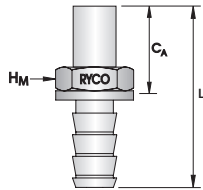

HOSE SIZE		TUBE SIZE	DASH SIZE	MALE HEX		IMPERIAL STANDPIPE				
DN	inch	inch		inch	mm	PART NO	CA		L	
							inch	mm	inch	mm
6	1/4	1/4	-0404	1/2		<b>8180-0404</b>	1.18	30	1.93	49
6	1/4	5/16	-0405	1/2		<b>8180-0405</b>	1.18	30	1.93	49
6	1/4	3/8	-0406	1/2		<b>8180-0406</b>	1.22	31	1.97	50
10	3/8	3/8	-0606	9/16		<b>8180-0606</b>	1.22	31	2.09	53
10	3/8	1/2	-0608	9/16		<b>8180-0608</b>	1.22	31	2.09	53
12	1/2	1/2	-0808	11/16		<b>8180-0808</b>	1.22	31	2.20	56
19	3/4	3/4	-1212	1.1/16	27	<b>8180-1212</b>	1.77	45	3.19	81

**UNO (O RING BOSS)**

**8200**

**O RING SUPPLIED**

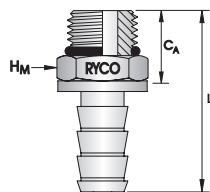

HOSE SIZE		THR D SIZE	TUBE SIZE	DASH SIZE	MALE HEX		UN O RING MALE (O RING BOSS)				
DN	inch	inch	inch		inch	mm	PART NO	CA		L	
								inch	mm	inch	mm
12	1/2	3/4	1/2	-0812	7/8	22	<b>8200-0812</b>	0.79	20	1.81	46

**NOTE:** Hose Compatibility for the **8000** series can be found on page 324.

<b>200 COUPLING NIPPLE</b>	<b>8100</b>
----------------------------	-------------

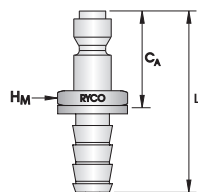

HOSE SIZE	DASH SIZE	BARB NIPPLES FOR RYCO 200 AIR COUPLING	
-----------	-----------	--	--

DN	HOSE SIZE		PART NO	CA		L	
	inch	inch		inch	mm	inch	mm
6	1/4	-0404	<b>8100-0404</b>	1.06	27	1.81	46
10	3/8	-0604	<b>8100-0604</b>	1.06	27	1.93	49

<b>STANDPIPE</b>	<b>8640</b>
------------------	-------------

**METRIC MALE FLARE**

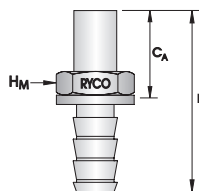

HOSE SIZE	TUBE SIZE	DASH SIZE	MALE HEX	METRIC STANDPIPE			
-----------	-----------	-----------	----------	------------------	--	--	--

DN	HOSE SIZE		DASH SIZE	HM-SPANNER		PART NO	CA		L	
	inch	mm		inch	mm		inch	mm	inch	mm
6	1/4	6	-0406	1/2		<b>8640-0406</b>	1.18	30	1.93	49
6	1/4	8	-0408	1/2		<b>8640-0408</b>	1.18	30	1.93	49
19	3/4	20	-1220	1.1/8		<b>8640-1220</b>	1.85	47	3.27	83
19	3/4	22	-1222	1.1/8		<b>8640-1222</b>	1.54	39	2.95	75

**NOTE:** Hose Compatibility for the **8000** series can be found on page 324.



# COUPLINGS

## 33000 SERIES SUCTION AND RETURN COUPLINGS

### HOSE COMPATIBILITY FOR 33000 SERIES

For RYCO Hose Series SRX and SRF all sizes.

**33000** Series require a suitable clamp around the outside of the hose.

HOSE DASH SIZE	CLAMP PART NO	CLAMP ADJUSTMENT RANGE	RECOMMENDED TIGHTENING TORQUE	
			Nm	ft. lbs
		d mm		
-12	RSC-3134	31 to 34	20	15
-16	RSC-3740*	37 to 40	20	15
	RSC-4043*	40 to 43	20	15
-20	RSC-4347*	43 to 47	20	15
	RSC-4751*	47 to 51	20	15
-24	RSC-5155	51 to 55	20	15
-32	RSC-6368	63 to 68	25	18
-40	RSC-7379	73 to 79	25	18
-48	RSC-8591	85 to 91	25	18

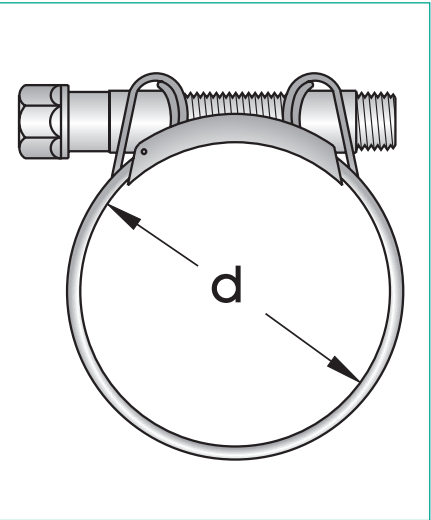

\* Due to the manufacturing tolerance on outside diameter of the hose and the range of adjustment of the clamp, it is necessary to confirm correct clamp at time of assembly.

### BSPP

### 33111

60° SEAT  
FLAT SEAT  
O RING & RETAINING RING  
SUPPLIED

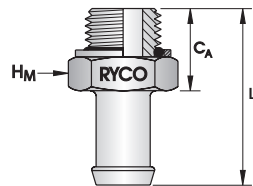

HOSE SIZE		THRD SIZE	DASH SIZE	MALE HEX	BSPP O RING MALE					
DN	inch	inch		HM-SPANNER		PART NO	CA		L	
				inch	mm		inch	mm	inch	mm
25	1	3/4	-1612	1.3/16	30	<b>33111-1612</b>	1.02	26	2.40	61
25	1	1	-1616		36	<b>33111-1616</b>	1.18	30	2.56	65
31	1.1/4	3/4	-2012		36	<b>33111-2012</b>	1.02	26	2.40	61
31	1.1/4	1	-2016		36	<b>33111-2016</b>	1.18	30	2.56	65
31	1.1/4	1.1/4	-2020		46	<b>33111-2020</b>	1.26	32	2.64	67
38	1.1/2	1	-2416	1.5/8	41	<b>33111-2416</b>	1.18	30	2.56	65
38	1.1/2	1.1/4	-2420		46	<b>33111-2420</b>	1.26	32	2.64	67

**NOTE:** Hose Compatibility for the **33000** series can be found on page 332.

## 33000 SERIES SUCTION AND RETURN COUPLINGS

<b>BSPP</b>	<b>33410</b>
-------------	--------------

**60° SEAT  
FLAT SEAT**

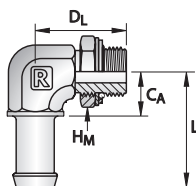

HOSE SIZE		THRD SIZE	DASH SIZE	MALE HEX	BSPP O RING MALE 90° ELBOW							
DN	inch	inch		HM-SPANNER		PART NO	CA		L		DL	
				inch	mm		inch	mm	inch	mm	inch	mm
25	1	1/2	-1608	1.1/16	27	<b>33410-1608</b>	0.98	25	2.36	60	1.81	46
25	1	3/4	-1612	1.1/16	27	<b>33410-1612</b>	0.98	25	2.36	60	1.85	47
31	1.1/4	3/4	-2012	1.5/16		<b>33410-2012</b>	1.18	30	2.56	65	1.97	50
31	1.1/4	1	-2016	1.5/16		<b>33410-2016</b>	1.18	30	2.56	65	2.05	52
31	1.1/4	1.1/4	-2020	1.5/8	41	<b>33410-2020</b>	1.42	36	2.80	71	2.24	57
38	1.1/2	1	-2416	1.5/8	41	<b>33410-2416</b>	1.42	36	2.80	71	2.24	57
38	1.1/2	1.1/4	-2420	1.5/8	41	<b>33410-2420</b>	1.42	36	2.80	71	2.24	57

<b>BSPP</b>	<b>33020</b>	<b>33024</b>
-------------	--------------	--------------

**60° SEAT  
FLAT SEAT**

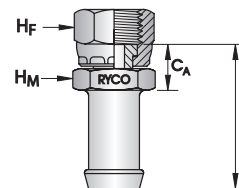
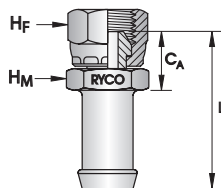

HOSE SIZE		THRD SIZE	DASH SIZE	MALE HEX	FEMALE HEX	BSPP FEMALE						BSPP FEMALE FLAT FACE					
DN	inch	inch		HM-SPANNER		HF-SPANNER		PART NO	CA		L		PART NO	CA		L	
				inch	mm	inch	mm		inch	mm	inch	mm		inch	mm	inch	mm
19	3/4	3/4	-1212	1.1/16	27	1.1/4	32	<b>33020-1212</b>	0.94	24	2.32	59	<b>33024-1212</b>	0.94	24	2.36	60
25	1	1	-1616	1.1/4	32	1.1/2	38	<b>33020-1616</b>	1.06	27	2.44	62	<b>33024-1616</b>	0.94	24	2.36	60
31	1.1/4	1.1/4	-2020	1.5/8	41	2	50	<b>33020-2020</b>	1.22	31	2.64	67	<b>33024-2020</b>	0.98	25	2.36	60
38	1.1/2	1.1/2	-2424		46	2.3/16	55	<b>33020-2424</b>	1.26	32	2.68	68					
51	2	2	-3232	2.3/8	60	2.3/4	70	<b>33020-3232</b>	1.61	41	2.99	76					

**NOTE:** Hose Compatibility for the **33000** series can be found on page 332.

INTRODUCTION

HOSE

COUPLINGS

ADAPTORS

TECHNICAL

# COUPLINGS

## 33000 SERIES SUCTION AND RETURN COUPLINGS

<b>BSPT</b>	<b>33010</b>
-------------	--------------

60° SEAT  
FLAT SEAT

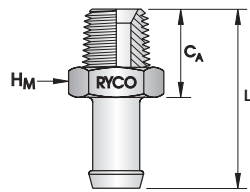

HOSE SIZE		THRD SIZE	DASH SIZE	MALE HEX		BSPT MALE				
DN	inch	inch		HM-SPANNER		PART NO	CA		L	
				inch	mm		inch	mm	inch	mm
19	3/4	3/8	-1206	1.1/16	27	<b>33010-1206</b>	0.91	23	2.28	58
19	3/4	1/2	-1208	7/8	22	<b>33010-1208</b>	1.10	28	2.48	63
19	3/4	3/4	-1212	1.1/16	27	<b>33010-1212</b>	1.10	28	2.48	63
19	3/4	1	-1216		36	<b>33010-1216</b>	1.42	36	2.80	71
25	1	3/4	-1612	1.3/16	30	<b>33010-1612</b>	1.14	29	2.52	64
25	1	1	-1616		36	<b>33010-1616</b>	1.42	36	2.80	71
25	1	1.1/4	-1620		46	<b>33010-1620</b>	1.50	38	2.87	73
31	1.1/4	3/4	-2012		36	<b>33010-2012</b>	1.22	31	2.60	66
31	1.1/4	1	-2016		36	<b>33010-2016</b>	1.42	36	2.80	71
31	1.1/4	1.1/4	-2020		46	<b>33010-2020</b>	1.50	38	2.87	73
31	1.1/4	1.1/2	-2024	2	50	<b>33010-2024</b>	1.54	39	2.91	74
38	1.1/2	1	-2416	1.5/8	41	<b>33010-2416</b>	1.42	36	2.80	71
38	1.1/2	1.1/4	-2420		46	<b>33010-2420</b>	1.50	38	2.87	73
38	1.1/2	1.1/2	-2424	2	50	<b>33010-2424</b>	1.54	39	2.91	74
51	2	1	-3216	2.3/16	55	<b>33010-3216</b>	1.54	39	2.91	74
51	2	1.1/2	-3224	2.3/16	55	<b>33010-3224</b>	1.57	40	2.95	75
51	2	2	-3232		65	<b>33010-3232</b>	1.73	44	3.15	80

**NOTE:** Hose Compatibility for the **33000** series can be found on page 332.

## 33000 SERIES SUCTION AND RETURN COUPLINGS

<b>BSPT</b>	<b>33400</b>
-------------	--------------

60° SEAT  
FLAT SEAT

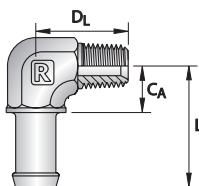

HOSE SIZE		THRD SIZE	DASH SIZE	MALE HEX	BSPT MALE 90° ELBOW							
DN	inch	inch		HM-SPANNER		PART NO	CA		L		DL	
				inch	mm		inch	mm	inch	mm	inch	mm
19	3/4	1/2	-1208	7/8	22	<b>33400-1208</b>	0.87	22	2.24	57	1.46	37
19	3/4	3/4	-1212	1.1/16	27	<b>33400-1212</b>	0.98	25	2.36	60	1.57	40
25	1	1/2	-1608	1.1/16	27	<b>33400-1608</b>	0.98	25	2.36	60	1.69	43
25	1	3/4	-1612	1.1/16	27	<b>33400-1612</b>	0.98	25	2.36	60	1.57	40
25	1	1	-1616	1.5/16		<b>33400-1616</b>	1.18	30	2.56	65	1.97	50
25	1	1.1/4	-1620	1.5/8	41	<b>33400-1620</b>	1.42	36	2.80	71	2.40	61
31	1.1/4	3/4	-2012	1.1/16	27	<b>33400-2012</b>	1.18	30	2.56	65	1.77	45
31	1.1/4	1	-2016	1.1/16	27	<b>33400-2016</b>	1.18	30	2.56	65	1.97	50
31	1.1/4	1.1/4	-2020	1.5/8	41	<b>33400-2020</b>	1.42	36	2.80	71	2.40	61
31	1.1/4	1.1/2	-2024	1.7/8		<b>33400-2024</b>	1.61	41	2.99	76	2.64	67
38	1.1/2	1	-2416	1.5/8	41	<b>33400-2416</b>	1.42	36	2.80	71	2.36	60
38	1.1/2	1.1/4	-2420	1.5/8	41	<b>33400-2420</b>	1.42	36	2.80	71	2.36	60
38	1.1/2	1.1/2	-2424	1.7/8		<b>33400-2424</b>	1.61	41	2.99	76	2.64	67
51	2	1.1/4	-3220	2.1/2		<b>33400-3220</b>	2.09	53	3.46	88	2.95	75
51	2	1.1/2	-3224	2.1/2		<b>33400-3224</b>	2.09	53	3.46	88	2.95	75

<b>NPT</b>	<b>33090</b>	<b>33400N</b>
------------	--------------	---------------

60° SEAT

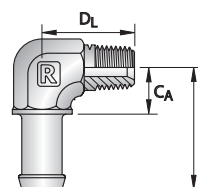
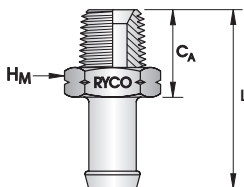

HOSE SIZE		THRD SIZE	DASH SIZE	MALE HEX	NPT MALE				NPT MALE 90° ELBOW								
DN	inch	inch		HM-SPANNER		PART NO	CA		L		PART NO	CA		L		DL	
				inch	mm		inch	mm	inch	mm		inch	mm	inch	mm	inch	mm
19	3/4	1/2	-1208								<b>33400N-1208</b>	0.87	22	2.24	57	1.46	37
25	1	3/4	-1612	1.1/8		<b>33090-1612</b>	1.14	29	2.52	64							
25	1	1	-1616	1.3/8		<b>33090-1616</b>	1.42	36	2.80	71	<b>33400N-1616</b>	1.18	30	2.56	65	1.97	50
31	1.1/4	3/4	-2012	1.3/8		<b>33090-2012</b>	1.22	31	2.60	66							
31	1.1/4	1.1/4	-2020	1.3/4		<b>33090-2020</b>	1.50	38	2.87	73							
38	1.1/2	1.1/2	-2424	2	50	<b>33090-2424</b>	1.54	39	2.91	74							

**NOTE:** Hose Compatibility for the **33000** series can be found on page 332.

INTRODUCTION

HOSE

COUPLINGS

ADAPTORS

TECHNICAL

# COUPLINGS

## 33000 SERIES SUCTION AND RETURN COUPLINGS

JSEAL™ / JIC	33040
--------------	-------

CONVEX SEAT

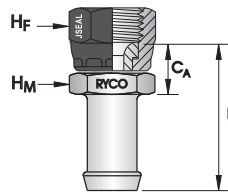

HOSE SIZE		THRD SIZE	DASH SIZE	MALE HEX		FEMALE HEX		JSEAL™ / JIC FEMALE					
DN	inch	inch		HM-SPANNER		HF-SPANNER		PART NO		Ca		L	
				inch	mm	inch	mm		inch	mm	inch	mm	
25	1	1.1/16	-1617	1.1/4	32	1.1/4	32	<b>33040-1617</b>	0.94	24	2.36	60	
31	1.1/4	1.5/8	-2026	1.3/4		2	50	<b>33040-2026</b>	1.18	30	2.56	65	

## 33000 SERIES SUCTION AND RETURN COUPLINGS

### DIMENSIONS FOR SAE CODE 61 AND CODE 62 FLANGES, AND RYCO CODE 62C FLANGES

NOMINAL FLANGE	CODE 61				CODE 62				CODE 62C			
	B		T		B		T		B		T	
inch	mm	inch	mm	inch	mm	inch	mm	inch	mm	inch	mm	inch
1/2	30,2	1.19	6,73	0.265	31,8	1.25	7,75	0.305				
5/8	34,0	1.34	6,73	0.265								
3/4	38,1	1.50	6,73	0.265	41,3	1.63	8,76	0.345	41,3	1.63	14,20	0.559
1	44,5	1.75	8,00	0.315	47,6	1.88	9,53	0.375	47,6	1.88	14,20	0.559
1.1/4	50,8	2.00	8,00	0.315	54,0	2.12	10,29	0.405	54,0	2.12	14,20	0.559
1.1/2	60,3	2.38	8,00	0.315	63,5	2.50	12,57	0.495	63,5	2.50	14,20	0.559
2	71,4	2.81	9,53	0.375	79,4	3.13	12,57	0.495	79,4	3.13	14,20	0.559
2.1/2	84,1	3.31	9,53	0.375								
3	101,6	4.00	9,53	0.375								

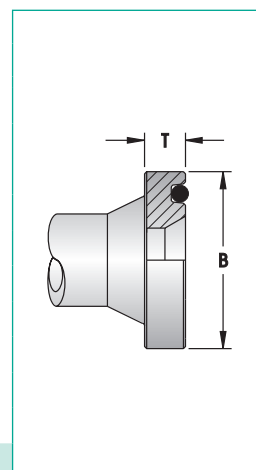

**NOTE:** RYCO Code 62C fittings conform to the flange OD and bolt hole patterns of SAE Code 62 but require special flange clamps. RYCO Code 62C flange heads are thicker than SAE Code 62 and measure T = 14,2 mm (0.559 inch) in all sizes.

SAE FLANGE	33130	33150
------------	-------	-------

**RYCO CODE 61 CLAMPS - SEE RYCO ADAPTOR CATALOG O RING NOT SUPPLIED**

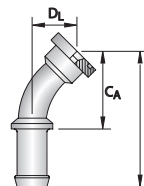
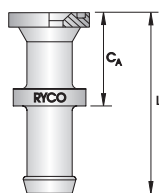

HOSE SIZE	NOM. FLANGE SIZE	DASH SIZE	CODE 61 FLANGE				CODE 61 FLANGE 45° TUBE BEND								
			PART NO	CA		L		PART NO	CA		L		DL		
DN	inch	inch		inch	mm	inch	mm		inch	mm	inch	mm	inch	mm	
25	1	1	-1616	<b>33130-1616</b>	1.97	50	3.35	85	<b>33150-1616</b>	2.99	76	4.37	111	1.34	34
25	1	1.1/4	-1620	<b>33130-1620</b>	1.97	50	3.35	85	<b>33150-1620</b>	2.99	76	4.37	111	1.34	34
31	1.1/4	1.1/4	-2020	<b>33130-2020</b>	1.97	50	3.35	85	<b>33150-2020</b>	3.23	82	4.61	117	1.42	36
31	1.1/4	1.1/2	-2024	<b>33130-2024</b>	1.97	50	3.35	85	<b>33150-2024</b>	3.23	82	4.61	117	1.42	36
38	1.1/2	1.1/4	-2420	<b>33130-2420</b>	1.93	49	3.31	84							
38	1.1/2	1.1/2	-2424	<b>33130-2424</b>	1.97	50	3.35	85	<b>33150-2424</b>	3.62	92	5.00	127	1.50	38
38	1.1/2	2	-2432	<b>33130-2432</b>	2.05	52	3.43	87	<b>33150-2432</b>	3.66	93	5.04	128	1.54	39
51	2	2	-3232	<b>33130-3232</b>	2.05	52	3.43	87	<b>33150-3232</b>	3.19	81	4.57	116	1.50	38
51	2	2.1/2	-3240	<b>33130-3240</b>	2.05	52	3.43	87	<b>33150-3240</b>	3.19	81	4.57	116	1.50	38
63	2.1/2	2	-4032	<b>33130-4032</b>	2.05	52	4.80	122	<b>33150-4032</b>	3.35	85	6.10	155	1.50	38

**NOTE:** Hose Compatibility for the **33000** series can be found on page 332.

INTRODUCTION

HOSE

COUPLINGS

ADAPTORS

TECHNICAL

# COUPLINGS

## 33000 SERIES SUCTION AND RETURN COUPLINGS

<b>SAE FLANGE</b>	<b>33170</b>
-------------------	--------------

**RYCO  
CODE 61  
CLAMPS - SEE RYCO  
ADAPTOR CATALOG  
O RING NOT SUPPLIED**

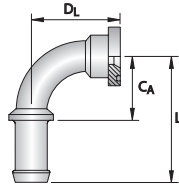

HOSE SIZE		NOM. FLANGE SIZE	DASH SIZE	CODE 61 FLANGE 90° TUBE BEND						
DN	inch	inch		PART NO	CA		L		DL	
					inch	mm	inch	mm	inch	mm
25	1	1	-1616	<b>33170-1616</b>	2.52	64	3.90	99	2.76	70
25	1	1.1/4	-1620	<b>33170-1620</b>	3.23	82	4.61	117	3.66	93
31	1.1/4	1	-2016	<b>33170-2016</b>	2.83	72	4.21	107	3.23	82
31	1.1/4	1.1/4	-2020	<b>33170-2020</b>	2.83	72	4.21	107	3.23	82
31	1.1/4	1.1/2	-2024	<b>33170-2024</b>	2.83	72	4.21	107	3.23	82
38	1.1/2	1.1/2	-2424	<b>33170-2424</b>	3.50	89	4.88	124	3.90	99
38	1.1/2	2	-2432	<b>33170-2432</b>	3.50	89	4.88	124	3.98	101
51	2	2	-3232	<b>33170-3232</b>	4.06	103	5.43	138	4.53	115
51	2	2.1/2	-3240	<b>33170-3240</b>	4.06	103	5.43	138	4.53	115
63	2.1/2	2	-4032	<b>33170-4032</b>	4.25	108	7.01	178	4.53	115

<b>UNO (O RING BOSS)</b>	<b>33200</b>	<b>33420</b>
--------------------------	--------------	--------------

**O RING SUPPLIED**

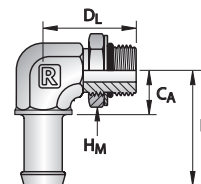
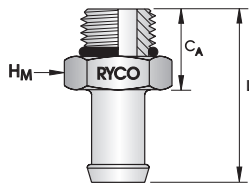

HOSE SIZE		THRD SIZE	TUBE SIZE	DASH SIZE	MALE HEX	UN O RING MALE (O RING BOSS)					UN O RING MALE (O RING BOSS) 90° ELBOW							
DN	inch	inch	inch		HM-SPANNER	PART NO	CA		L		PART NO	CA		L		DL		
					inch	mm	inch	mm	inch	mm		inch	mm	inch	mm	inch	mm	
19	3/4	7/8	3/4	-1214	1.1/16	27	<b>33200-1214</b>	0.83	21	2.20	56	<b>33420-1214</b>	0.98	25	2.36	60	1.81	46
19	3/4	1.1/16	1	-1217	1.1/4	32	<b>33200-1217</b>	0.98	25	2.36	60	<b>33420-1217</b>	1.18	30	2.56	65	2.05	52
19	3/4	1.5/16	3/4	-1221	1.1/2	38	<b>33200-1221</b>	2.44	62	3.82	97	<b>33420-1221</b>	1.18	30	2.56	65	2.05	52
25	1	1.1/16	1	-1617	1.1/4	32	<b>33200-1617</b>	0.98	25	2.36	60	<b>33420-1617</b>	1.18	30	2.56	65	2.05	52
25	1	1.5/16	5/8	-1621	1.1/2	38	<b>33200-1621</b>	1.06	27	2.44	62	<b>33420-1621</b>	1.18	30	2.56	65	2.05	52
31	1.1/4	7/8	3/4	-2014	1.3/8		<b>33200-2014</b>	0.94	24	2.32	59							
31	1.1/4	1.1/16	7/8	-2017	1.3/8		<b>33200-2017</b>	1.06	27	2.44	62	<b>33420-2017</b>	1.18	30	2.56	65	2.05	52
31	1.1/4	1.3/16	1	-2019	1.3/8		<b>33200-2019</b>	1.06	27	2.44	62	<b>33420-2019</b>	1.18	30	2.56	65	2.01	51
31	1.1/4	1.5/16	1.1/4	-2021	1.1/2	38	<b>33200-2021</b>	1.06	27	2.44	62	<b>33420-2021</b>	1.18	30	2.56	65	2.05	52
31	1.1/4	1.5/8	3/4	-2026	2	50	<b>33200-2026</b>	1.10	28	2.48	63	<b>33420-2026</b>	1.42	36	2.80	71	2.24	57
38	1.1/2	1.1/16	1	-2417	1.5/8	41	<b>33200-2417</b>	1.06	27	2.44	62							
38	1.1/2	1.5/16	1.1/4	-2421	1.5/8	41	<b>33200-2421</b>	1.06	27	2.44	62	<b>33420-2421</b>	1.42	36	2.80	71	2.24	57
38	1.1/2	1.5/8	1.1/2	-2426	2	50	<b>33200-2426</b>	1.10	28	2.48	63	<b>33420-2426</b>	1.42	36	2.80	71	2.24	57
38	1.1/2	1.7/8	1.1/2	-2430	2.3/16	55	<b>33200-2430</b>	1.18	30	2.56	65							
51	2	1.7/8	1.1/2	-3230	2.3/16	55	<b>33200-3230</b>	1.18	30	2.56	65							

**NOTE:** Hose Compatibility for the **33000** series can be found on page 332.



## V000 SERIES FIELD ATTACHABLE COUPLINGS

### HOSE COMPATIBILITY FOR V000 SERIES

#### FOR RYCO SURVIVOR RQP5 AND TRUCKER T5 HOSE SERIES

RYCO V000 Series Ferrules follow the dash size of **SURVIVOR RQP5** and **TRUCKER T5** series hose. **RQP5** and **T5** Series are SAE 100R5 specification hose, and, accordingly the dash size is the corresponding tube size. SAE 100R5 hose internal diameters (nominal bores), unlike SAE 100R1, R2, etc, are smaller than their dash sizes. For example, **T58** has nominal tube size of 1/2" and internal diameter of 13/32", whereas **T18** and **T28** have nominal bore size of 1/2" and internal diameter of 1/2". The reason for this difference is that T5 Series hoses are often used in applications where hose is connected to steel or copper tubing. The hose is sized so that its flow diameter is approximately the same as the flow diameter of the same nominal size tubing. Hence, the hose size relates to the nominal tube size.

**RYCO V000** Series Ferrules are designed to match with **RYCO 6000** Series Inserts.

**RYCO 6000** Series Inserts have the same nominal sizing as their corresponding **T1** and **T2** Series Hose. Therefore, V000 Series Ferrules and matching 6000 Series Inserts have different "dash" sizes. When matched together, V000 Series Couplings have the same dash size as the 6000 Series Inserts. See table below.

The chart below shows the relationship of Part Numbers for Ferrules, Inserts and Couplings for each size.

SURVIVOR RQP5	TRUCKER T5	HOSE (TUBE) DASH SIZE	HOSE ID INCH	V000 SERIES FERRULE	FERRULE DASH SIZE	6000 SERIES INSERTS	INSERT DASH SIZE	V000 SERIES COUPLINGS	COUPLING DASH SIZE
RQP54	T54	-04	3/16	V000-04	-04	6xxx-03	-03	Vxxx-03	-03
RQP55	T55	-05	1/4	V000-05	-05	6xxx-04	-04	Vxxx-04	-04
RQP56	T56	-06	5/16	V000-06	-06	6xxx-05	-05	Vxxx-05	-05
RQP58	T58	-08	13/32	V000-08	-08	6xxx-06	-06	Vxxx-06	-06
RQP510	T510	-10	1/2	V000-10	-10	6xxx-08	-08	Vxxx-08	-08
RQP512	T512	-12	5/8	V000-12	-12	6xxx-10	-10	Vxxx-10	-10
RQP516	T516	-16	7/8	V000-16	-16	6xxx-14	-14	Vxxx-14	-14
RQP520	T520	-20	1.1/8	V000-20	-20	6xxx-18	-18	Vxxx-18	-18
RQP524	T524	-24	1.3/8	V000-24	-24	6xxx-22	-22	Vxxx-22	-22
RQP532	T532	-32	1.13/16	V000-32	-32	6xxx-29	-29	Vxxx-29	-29

### ADDITIONAL COUPLING END STYLES

Pages 233 to 249 show the T4000 Series Coupling End Styles that are also used with **RQP5** and **T5** hose.

As **RYCO V000** Series Ferrules match with **RYCO 6000** Series Inserts it is possible to use any **RYCO 6000** Insert from -03 to -10 listed in the **6000** Series Field Attachable Inserts with the matching Series Ferrule.

Refer to RYCO for the availability of other **6000** Series Field Attachable Inserts.

### CUT-OFF ALLOWANCE (CA) DIMENSIONS FOR FIELD ATTACHABLES

Due to differences in Ferrule design, many Cut-Off Allowance (CA) dimensions vary between each Ferrule Series for the same matched Insert/Hose size.

The Cut-Off Allowance (CA) dimensions published in "V Series Field Attachable Inserts" section allow for the Ferrule being eased back 5/8 of a turn after the hose has bottomed in the ferrule, as per "Field Attachable Assembly Instructions" (ease back between 1/2 and 3/4 of a turn).

The Cut-Off Allowance (CA) values for **6000** Series Inserts, published in the tables on pages 341 to 352 are for **6000** Series Inserts used with **V000** Series Ferrules. If using V000 Series Ferrules with other matched **6000** Series Inserts listed on pages 355 to 385, contact RYCO Hydraulics Technical Department for the correct Cut-Off Allowance (CA).

If the hose assembly length is critical, when calculating the Cut Length of hose, you must also allow for an increase in length of hose when the coupling is attached, due to compression within the coupling; see page 354.

For further information about Hose Assemblies and Cut-Off Allowances (CA), see pages 465 to 471 of the Technical Section.

**NOTE:** Hose Compatibility for the **V000** series can be found on page 323.

# COUPLINGS

## HOW TO ORDER RYCO V SERIES FIELD ATTACHABLE COUPLINGS

### HOW TO ORDER

**EXAMPLE** To order 1/2" NPT male insert and ferrule for **T58** (13/32") hose.

(a) Individually

Order ferrule **V000-08**.

**V000 Series** ferrules are used on **T5** hose; see chart on page 339, or chart for Couplings Selection on **T5** page 116. Ferrule Dash Size -08 is same as Dash Size of hose.

Order insert **6090-0608** (6000 Series).

**T58** hose uses 6000-06 size inserts, see page 339.

(b) Complete Coupling

Order **V090-0608**.

Simply replace the first character of the insert's part number with the first character of the ferrule's part number.

(replace 6 with V): **6090-0608** » **V090-0608**

The **V000 Series** Couplings on pages 341 to page 352 clearly show the Insert, Ferrule and Complete Coupling part numbers for each size of hose.

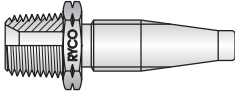
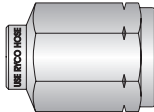
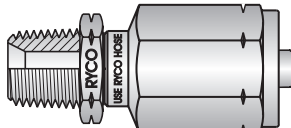
6090-0608 insert	plus V000-08 ferrule equals	V090-0608 complete coupling
		

### HOSE BRANDING:

In common with industry practice, **RYCO RQP5** and **T5** hoses are branded with their Part Number, and their Actual Inside Diameter. For example:

<b>RYCO TRUCKER T55 1/4" MAX WP 3050 PSI•210 BAR MALAYSIA</b>	<b>DOT RYCO MMY 1/4 AII • RYCO AIR BRAKE (METRIC SIZE 6.3) SAE J1402 AII</b>
<b>RYCO TRUCKER T56 5/16" MAX WP 2250 PSI•155 BAR MALAYSIA</b>	<b>DOT RYCO MMY 5/16 AII • RYCO AIR BRAKE (METRIC SIZE 8) SAE J1402 AII</b>
<b>RYCO SURVIVOR RQP55 1/4" MAX WP 3050 PSI•210 BAR MALAYSIA</b>	<b>DOT RYCO MMY 1/4 AII • RYCO AIR BRAKE (METRIC SIZE 6.3) SAE J1402 AII</b>
<b>RYCO SURVIVOR RQP56 5/16" MAX WP 3050 PSI•210 BAR MALAYSIA</b>	<b>DOT RYCO MMY 5/16 AII • RYCO AIR BRAKE (METRIC SIZE 8) SAE J1402 AII</b>

When ordering hose, it is important to be clear about what size is being referred to.

For example **T55** is -05 or **5/16"** Nominal Dash Size, and **1/4"** Actual Inside Diameter.

**T56** is -06 or **3/8"** Nominal Dash Size, and **5/16"** Actual Inside Diameter.

Both hoses can be referred to as **5/16"**, depending on whether Nominal or Actual Inside Diameter is being referred to.

Other sizes that crossover are:

**T54** and **T55**; **T58** and **T510**; and **T510** and **T512**.

**RQP54** and **RQP55**; **RQP58** and **RQP510**; and **RQP510** and **RQP512**.

It is **NOT RECOMMENDED** to refer to the size of the hose only, or there may be confusion about whether it is Actual or Nominal Diameter.

It is **RECOMMENDED** to only refer to the Part Number of the hose. Example: **T56**.

If the size is mentioned, the Part Number of the hose must also be included to remove any confusion.

**EXAMPLE: 5/16" T56.**

**NOTE:** Hose Compatibility for the **V000** series can be found on page 323.

## V000 SERIES FIELD ATTACHABLE COUPLINGS

<b>BSPT</b>	<b>V000 FERRULE</b>	<b>6010 INSERT</b>	<b>V010 COUPLING</b>
-------------	-------------------------	------------------------	--------------------------

60° SEAT

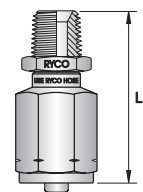
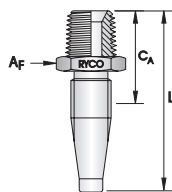
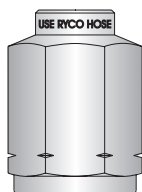

HOSE SIZE ACTUAL ID	THRD SIZE	DASH SIZE	BACK UP Af	BSPT MALE							
------------------------	--------------	--------------	---------------	--------------	--	--	--	--	--	--	--

DN	inch	inch		Af-SPANNER		PART NO	PART NO	Ca		L		PART NO
				inch	mm			inch	mm	inch	mm	
6	1/4	1/8	-0402	5/8	16	V000-05	6010-0402	1.22	31	2.24	57	V010-0402
6	1/4	1/4	-0404	5/8	16	V000-05	6010-0404	1.38	35	2.44	62	V010-0404
8	5/16	1/4	-0504	5/8	16	V000-06	6010-0504	1.30	33	2.36	60	V010-0504
8	5/16	3/8	-0506	11/16		V000-06	6010-0506	1.30	33	2.36	60	V010-0506
10	3/8	1/4	-0604	11/16		V000-08	6010-0604	1.26	32	2.60	66	V010-0604
10	3/8	3/8	-0606	11/16		V000-08	6010-0606	1.26	32	2.60	66	V010-0606
10	3/8	1/2	-0608	7/8	22	V000-08	6010-0608	1.54	39	2.83	72	V010-0608
12	1/2	1/2	-0808	7/8	22	V000-10	6010-0808	1.46	37	2.76	70	V010-0808
16	5/8	5/8	-1010	1.1/8		V000-12	6010-1010	1.77	45	3.19	81	V010-1010
16	5/8	3/4	-1012	1.1/8		V000-12	6010-1012	1.77	45	3.19	81	V010-1012
28	1.1/8	1.1/4	-1820			V000-20	6010-1820	2.28	58	3.54	90	V010-1820

<b>BSPP</b>	<b>V000 FERRULE</b>	<b>6020 INSERT</b>	<b>V020 COUPLING</b>
-------------	-------------------------	------------------------	--------------------------

60° SEAT

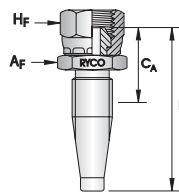
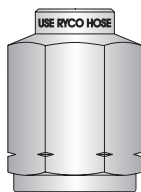

HOSE SIZE ACTUAL ID	THRD SIZE		BACK UP Af	FEMALE HEX	BSPP FEMALE							
------------------------	--------------	--	---------------	---------------	----------------	--	--	--	--	--	--	--

DN	inch	inch		Af-SPANNER		Hf-SPANNER		PART NO	PART NO	Ca		L		PART NO
				inch	mm	inch	mm			inch	mm	inch	mm	
5	3/16	1/8	-0302	5/8	16		14	V000-04	6020-0302	0.98	25	1.81	46	V020-0302
6	1/4	1/8	-0402	5/8	16		14	V000-05	6020-0402	1.22	31	2.24	57	V020-0402
6	1/4	1/4	-0404	11/16		3/4	19	V000-05	6020-0404	1.22	31	2.28	58	V020-0404
8	5/16	1/4	-0504	5/8	16	3/4	19	V000-06	6020-0504	1.14	29	2.20	56	V020-0504
8	5/16	3/8	-0506	11/16		7/8	22	V000-06	6020-0506	1.30	33	2.36	60	V020-0506
10	3/8	1/4	-0604	11/16		3/4	19	V000-08	6020-0604	1.10	28	2.40	61	V020-0604
10	3/8	3/8	-0606	13/16		7/8	22	V000-08	6020-0606	1.22	31	2.56	65	V020-0606
10	3/8	1/2	-0608	7/8	22	1.1/16	27	V000-08	6020-0608	1.30	33	2.60	66	V020-0608
12	1/2	1/2	-0808	1		1.1/16	27	V000-10	6020-0808	1.42	36	2.72	69	V020-0808
16	5/8	5/8	-1010	1.1/8		1.3/16	30	V000-12	6020-1010	1.50	38	2.91	74	V020-1010
16	5/8	3/4	-1012	1.1/8		1.1/4	32	V000-12	6020-1012	1.57	40	2.99	76	V020-1012
22	7/8	1	-1416	1.1/2	38	1.1/2	38	V000-16	6020-1416	1.57	40	2.64	67	V020-1416
28	1.1/8	1.1/4	-1820			2	50	V000-20	6020-1820	2.01	51	3.31	84	V020-1820

**NOTE:** Hose Compatibility for the V000 series can be found on page 323.

INTRODUCTION

HOSE

COUPLINGS

ADAPTORS

TECHNICAL

# COUPLINGS

## V000 SERIES FIELD ATTACHABLE COUPLINGS

<b>BSPP</b>	<b>V000 FERRULE</b>	<b>6270 INSERT</b>	<b>V270 COUPLING</b>
-------------	---------------------	--------------------	----------------------

60° SEAT

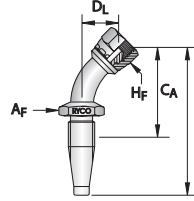
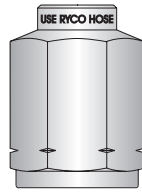

HOSE SIZE				THRD SIZE	DASH SIZE	BACK UP Af	FEMALE HEX		BSPP FEMALE 45° TUBE BEND								
DN	inch	inch		Af-SPANNER	Hf-SPANNER		PART NO		PART NO		CA		L		DL		PART NO
				inch	mm	inch	mm			inch	mm	inch	mm	inch	mm		
6	1/4	1/4	-0404	5/8	16	3/4	19	<b>V000-05</b>	<b>6270-0404</b>	1.85	47	2.87	73	0.67	17		<b>V270-0404</b>
8	5/16	3/8	-0506	5/8	16	7/8	22	<b>V000-06</b>	<b>6270-0506</b>	2.09	53	3.19	81	0.75	19		<b>V270-0506</b>
10	3/8	3/8	-0606	11/16		7/8	22	<b>V000-08</b>	<b>6270-0606</b>	2.05	52	3.35	85	0.71	18		<b>V270-0606</b>
12	1/2	1/2	-0608	13/16		1.1/16	27	<b>V000-10</b>	<b>6270-0808</b>	2.44	62	3.74	95	0.87	22		<b>V270-0808</b>
16	5/8	5/8	-1010	1		1.3/16	30	<b>V000-12</b>	<b>6270-1010</b>	2.72	69	4.13	105	0.91	23		<b>V270-1010</b>
35	1.3/8	1.1/2	-2224	2		2.3/16	55	<b>V000-24</b>	<b>6270-2224</b>	5.20	132	6.50	165	2.13	54		<b>V270-2224</b>

<b>BSPP</b>	<b>V000 FERRULE</b>	<b>6260 INSERT</b>	<b>V260 COUPLING</b>
-------------	---------------------	--------------------	----------------------

60° SEAT

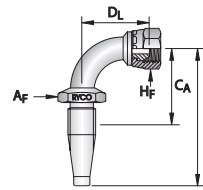
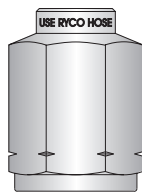

HOSE SIZE				THRD SIZE	DASH SIZE	BACK UP Af	FEMALE HEX		BSPP FEMALE 90° TUBE BEND								
DN	inch	inch		Af-SPANNER	Hf-SPANNER		PART NO		PART NO		CA		L		DL		PART NO
				inch	mm	inch	mm			inch	mm	inch	mm	inch	mm		
6	1/4	1/4	-0404	5/8	16	3/4	19	<b>V000-05</b>	<b>6260-0404</b>	1.54	39	2.60	66	1.14	29		<b>V260-0404</b>
8	5/16	3/8	-0506	5/8	16	7/8	22	<b>V000-06</b>	<b>6260-0506</b>	1.73	44	2.80	71	1.34	34		<b>V260-0506</b>
10	3/8	3/8	-0606	11/16		7/8	22	<b>V000-08</b>	<b>6260-0606</b>	1.73	44	3.03	77	1.30	33		<b>V260-0606</b>
10	3/8	1/2	-0608	3/4	19	1.1/16	27	<b>V000-08</b>	<b>6260-0608</b>	1.73	44	3.03	77	1.30	33		<b>V260-0608</b>
12	1/2	1/2	-0808	13/16		1.1/16	27	<b>V000-10</b>	<b>6260-0808</b>	2.09	53	3.39	86	1.69	43		<b>V260-0808</b>
16	5/8	5/8	-1010	1		1.3/16	30	<b>V000-12</b>	<b>6260-1010</b>	2.48	63	3.90	99	2.01	51		<b>V260-1010</b>
35	1.3/8	1.1/2	-2224	2		2.3/16	55	<b>V000-24</b>	<b>6260-2224</b>	4.45	113	5.75	146	4.17	106		<b>V260-2224</b>

**NOTE:** Hose Compatibility for the **V000** series can be found on page 323.

## V000 SERIES FIELD ATTACHABLE COUPLINGS

INTRODUCTION

HOSE

COUPLINGS

ADAPTORS

TECHNICAL

<b>NPT</b>	<b>V000 FERRULE</b>	<b>6090 INSERT</b>	<b>V090 COUPLING</b>
------------	---------------------	--------------------	----------------------

60° SEAT

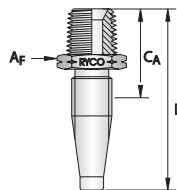
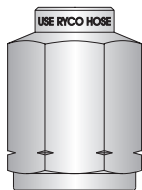

HOSE SIZE					BACK UP		NPT MALE					
ACTUAL ID	THRD SIZE	DASH SIZE	AF	AF-SPANNER		PART NO		CA		L		PART NO
DN	inch	inch		inch	mm			inch	mm	inch	mm	

5	3/16	1/8	-0302	7/16	11	V000-04	6090-0302	0.98	25	1.81	46	V090-0302
5	3/16	1/4	-0304	5/8	16	V000-04	6090-0304	1.18	30	1.97	50	V090-0304
6	1/4	1/8	-0402	7/16	11	V000-05	6090-0402	1.22	31	2.24	57	V090-0402
6	1/4	1/4	-0404	5/8	16	V000-05	6090-0404	1.38	35	2.44	62	V090-0404
6	1/4	3/8	-0406	11/16		V000-05	6090-0406	1.38	35	2.44	62	V090-0406
8	5/16	1/4	-0504	5/8	16	V000-06	6090-0504	1.30	33	2.36	60	V090-0504
8	5/16	3/8	-0506	11/16		V000-06	6090-0506	1.38	35	2.44	62	V090-0506
10	3/8	1/4	-0604	11/16		V000-08	6090-0604	1.26	32	2.60	66	V090-0604
10	3/8	3/8	-0606	11/16		V000-08	6090-0606	1.26	32	2.60	66	V090-0606
10	3/8	1/2	-0608	7/8	22	V000-08	6090-0608	1.54	39	2.83	72	V090-0608
12	1/2	3/8	-0806	7/8	22	V000-10	6090-0806	1.46	37	2.76	70	V090-0806
12	1/2	1/2	-0808	7/8	22	V000-10	6090-0808	1.65	42	2.91	74	V090-0808
16	5/8	1/2	-1008	1.1/8		V000-12	6090-1008	1.77	45	3.19	81	V090-1008
16	5/8	3/4	-1012	1.1/8		V000-12	6090-1012	1.77	45	3.19	81	V090-1012
22	7/8	1	-1416	1.3/8		V000-16	6090-1416	1.89	48	2.99	76	V090-1416
28	1.1/8	1.1/4	-1820			V000-20	6090-1820	2.28	58	3.54	90	V090-1820
35	1.3/8	1.1/2	-2224	2		V000-24	6090-2224	2.01	51	3.31	84	V090-2224

<b>JIC - MALE</b>	<b>V000 FERRULE</b>	<b>6030 INSERT</b>	<b>V030 COUPLING</b>
-------------------	---------------------	--------------------	----------------------

37° FLARE

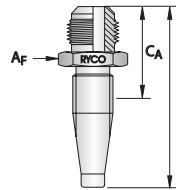
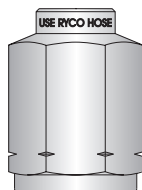

HOSE SIZE					BACK UP		JIC MALE						
ACTUAL ID	THRD SIZE	TUBE SIZE	DASH SIZE	AF	AF-SPANNER		PART NO		CA		L		PART NO
DN	inch	inch	inch		inch	mm			inch	mm	inch	mm	

5	3/16	7/16	1/4	-0307	5/8	16	V000-04	6030-0307	1.14	29	1.97	50	V030-0307
6	1/4	7/16	1/4	-0407	5/8	16	V000-05	6030-0407	1.38	35	2.40	61	V030-0407
6	1/4	1/2	5/16	-0408	5/8	16	V000-05	6030-0408	1.38	35	2.40	61	V030-0408
6	1/4	9/16	3/8	-0409	5/8	16	V000-05	6030-0409	1.38	35	2.44	62	V030-0409
6	1/4	3/4	1/2	-0412	13/16		V000-05	6030-0412	1.54	39	2.60	66	V030-0412
10	3/8	9/16	3/8	-0609	11/16		V000-08	6030-0609	1.26	32	2.56	65	V030-0609
10	3/8	3/4	1/2	-0612	13/16		V000-08	6030-0612	1.42	36	2.72	69	V030-0612
10	3/8	7/8	5/8	-0614	1		V000-08	6030-0614	1.50	38	2.83	72	V030-0614
12	1/2	3/4	1/2	-0812	13/16		V000-10	6030-0812	1.54	39	2.83	72	V030-0812
12	1/2	7/8	5/8	-0814	15/16	24	V000-10	6030-0814	1.61	41	2.91	74	V030-0814
12	1/2	1.1/16	3/4	-0817	1.1/8		V000-10	6030-0817	1.81	46	3.07	78	V030-0817
16	5/8	7/8	5/8	-1014	1.1/8		V000-12	6030-1014	1.77	45	3.19	81	V030-1014
16	5/8	1.1/16	3/4	-1017	1.1/8		V000-12	6030-1017	1.89	48	3.31	84	V030-1017

# COUPLINGS

## V000 SERIES FIELD ATTACHABLE COUPLINGS

<b>JSEAL™ / JIC</b>	<b>V000 FERRULE</b>	<b>6040 INSERT</b>	<b>V040 COUPLING</b>
---------------------	-------------------------	------------------------	--------------------------

CONVEX SEAT

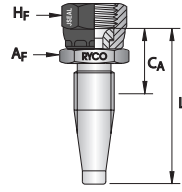
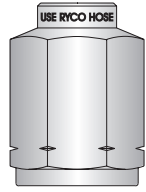

HOSE SIZE ACTUAL ID		THRD SIZE	TUBE SIZE	DASH SIZE	BACK UP Af	FEMALE HEX		JSEAL™ / JIC FEMALE							
DN	inch	inch	inch		Af-SPANNER		Hf-SPANNER		PART NO	PART NO	Ca		L		PART NO
					inch	mm	inch	mm			inch	mm	inch	mm	
5	3/16	7/16	1/4	-0307	9/16		9/16		V000-04	6040-0307	0.91	23	1.73	44	V040-0307
6	1/4	7/16	1/4	-0407	5/8	16	9/16		V000-05	6040-0407	1.14	29	2.17	55	V040-0407
6	1/4	1/2	5/16	-0408	5/8	16	5/8	16	V000-05	6040-0408	1.14	29	2.17	55	V040-0408
6	1/4	9/16	3/8	-0409	11/16		11/16		V000-05	6040-0409	1.14	29	2.20	56	V040-0409
6	1/4	3/4	1/2	-0412	3/4	19	7/8	22	V000-05	6040-0412	1.22	31	2.24	57	V040-0412
8	5/16	9/16	3/8	-0509	11/16		11/16		V000-06	6040-0509	1.06	27	2.13	54	V040-0509
10	3/8	7/16	1/4	-0607	11/16		9/16		V000-08	6040-0607	1.02	26	2.32	59	V040-0607
10	3/8	1/2	5/16	-0608	11/16		5/8	16	V000-08	6040-0608	1.02	26	2.32	59	V040-0608
10	3/8	9/16	3/8	-0609	11/16		11/16		V000-08	6040-0609	0.87	22	2.17	55	V040-0609
10	3/8	3/4	1/2	-0612	7/8	22	7/8	22	V000-08	6040-0612	1.14	29	2.44	62	V040-0612
10	3/8	7/8	5/8	-0614	1		1.1/16	27	V000-08	6040-0614	1.30	33	2.60	66	V040-0614
12	1/2	9/16	3/8	-0809	13/16		11/16		V000-10	6040-0809	1.22	31	2.52	64	V040-0809
12	1/2	3/4	1/2	-0812	7/8	22	7/8	22	V000-10	6040-0812	1.26	32	2.56	65	V040-0812
12	1/2	7/8	5/8	-0814	1		1.1/16	27	V000-10	6040-0814	1.54	39	2.80	71	V040-0814
12	1/2	1.1/16	3/4	-0817	1.1/8		1.1/4	32	V000-10	6040-0817	1.50	38	2.80	71	V040-0817
16	5/8	7/8	5/8	-1014	1		1.1/16	27	V000-12	6040-1014	1.50	38	2.91	74	V040-1014
16	5/8	1.1/16	3/4	-1017	1.1/4	32	1.1/4	32	V000-12	6040-1017	1.57	40	2.99	76	V040-1017
22	7/8	1.5/16	1	-1421	1.1/2	38	1.1/2	38	V000-16	6040-1421	1.57	40	2.64	67	V040-1421
28	1.1/8	1.5/8	1.1/4	-1826			2	50	V000-20	6040-1826	2.13	54	3.39	86	V040-1826
35	1.3/8	1.7/8	1.1/2	-2230	2		2.3/8	60	V000-24	6040-2230	1.77	45	3.07	78	V040-2230
46	1.13/16	2.1/2	2	-2940	2.3/4	70	2.7/8	73	V000-32	6040-2940	2.13	54	3.90	99	V040-2940

**NOTE:** Hose Compatibility for the V000 series can be found on page 323.

## V000 SERIES FIELD ATTACHABLE COUPLINGS

<b>JSEAL™ / JIC</b>	<b>V000 FERRULE</b>	<b>6070 INSERT</b>	<b>V070 COUPLING</b>
---------------------	---------------------	--------------------	----------------------

CONVEX SEAT

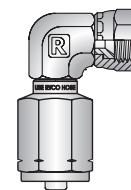
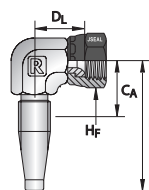
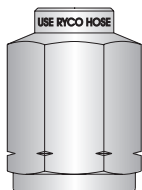

HOSE SIZE							JSEAL™ / JIC FEMALE 90° ELBOW									
ACTUAL ID	THRD SIZE	TUBE SIZE	DASH SIZE	FEMALE HEX		PART NO		CA		L		DL		PART NO		
DN	inch	inch	inch		HF-SPANNER				inch	mm	inch	mm	inch	mm		
6	1/4	7/16	1/4	-0407	9/16		<b>V000-05</b>	<b>6070-0407</b>	1.06	27	2.09	53	0.71	18	<b>V070-0407</b>	
6	1/4	1/2	5/16	-0408	5/8	16	<b>V000-05</b>	<b>6070-0408</b>	1.06	27	2.09	53	0.67	17	<b>V070-0408</b>	
6	1/4	9/16	3/8	-0409	11/16		<b>V000-05</b>	<b>6070-0409</b>	1.06	27	2.09	53	0.87	22	<b>V070-0409</b>	
10	3/8	9/16	3/8	-0609	11/16		<b>V000-08</b>	<b>6070-0609</b>	0.98	25	2.28	58	0.91	23	<b>V070-0609</b>	
10	3/8	3/4	1/2	-0612	7/8	22	<b>V000-08</b>	<b>6070-0612</b>	0.98	25	2.28	58	0.94	24	<b>V070-0612</b>	
12	1/2	3/4	1/2	-0812	7/8	22	<b>V000-10</b>	<b>6070-0812</b>	1.26	32	2.56	65	1.06	27	<b>V070-0812</b>	
12	1/2	7/8	5/8	-0814	1.1/16	27	<b>V000-10</b>	<b>6070-0814</b>	1.26	32	2.56	65	1.10	28	<b>V070-0814</b>	
12	1/2	1.1/16	3/4	-0817	1.1/4	32	<b>V000-10</b>	<b>6070-0817</b>	1.26	32	2.56	65	1.22	31	<b>V070-0817</b>	
16	5/8	7/8	5/8	-1014	1.1/16	27	<b>V000-12</b>	<b>6070-1014</b>	1.34	34	2.76	70	1.26	32	<b>V070-1014</b>	
16	5/8	1.1/16	3/4	-1017	1.1/4	32	<b>V000-12</b>	<b>6070-1017</b>	1.30	33	2.72	69	1.26	32	<b>V070-1017</b>	

<b>JSEAL™ / JIC</b>	<b>V000 FERRULE</b>	<b>6250 INSERT</b>	<b>V250 COUPLING</b>
---------------------	---------------------	--------------------	----------------------

CONVEX SEAT

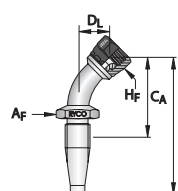
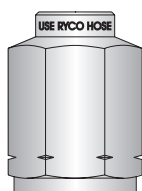

HOSE SIZE							JSEAL™ / JIC FEMALE 45° TUBE BEND										
ACTUAL ID	THRD SIZE	TUBE SIZE	DASH SIZE	BACK UP Af	FEMALE HEX		PART NO		CA		L		DL		PART NO		
DN	inch	inch	inch		AF-SPANNER		HF-SPANNER				inch	mm	inch	mm	inch	mm	
5	3/16	7/16	1/4	-0307	5/8	16	9/16		<b>V000-04</b>	<b>6250-0307</b>	1.61	41	2.44	62	0.59	15	<b>V250-0307</b>
6	1/4	7/16	1/4	-0407	5/8	16	9/16		<b>V000-05</b>	<b>6250-0407</b>	1.77	45	2.83	72	0.59	15	<b>V250-0407</b>
6	1/4	1/2	5/16	-0408	5/8	16	5/8	16	<b>V000-05</b>	<b>6250-0408</b>	1.77	45	2.83	72	0.59	15	<b>V250-0408</b>
6	1/4	9/16	3/8	-0409	5/8	16	11/16		<b>V000-05</b>	<b>6250-0409</b>	1.77	45	2.83	72	0.59	15	<b>V250-0409</b>
8	5/16	9/16	3/8	-0509	5/8	16	11/16		<b>V000-06</b>	<b>6250-0509</b>	1.85	47	2.95	75	0.55	14	<b>V250-0509</b>
10	3/8	9/16	3/8	-0609	11/16		11/16		<b>V000-08</b>	<b>6250-0609</b>	1.85	47	3.15	80	0.55	14	<b>V250-0609</b>
10	3/8	3/4	1/2	-0612	11/16		7/8	22	<b>V000-08</b>	<b>6250-0612</b>	1.89	48	3.19	81	0.67	17	<b>V250-0612</b>
12	1/2	3/4	1/2	-0812	13/16		7/8	22	<b>V000-10</b>	<b>6250-0812</b>	2.32	59	3.62	92	0.83	21	<b>V250-0812</b>
12	1/2	7/8	5/8	-0814	13/16		1.1/16	27	<b>V000-10</b>	<b>6250-0814</b>	2.40	61	3.70	94	0.87	22	<b>V250-0814</b>
16	5/8	1.1/16	3/4	-1017	1		1.1/4	32	<b>V000-12</b>	<b>6250-1017</b>	2.68	68	4.09	104	0.94	24	<b>V250-1017</b>
22	7/8	1.5/16	1	-1421	1.3/8		1.1/2	38	<b>V000-16</b>	<b>6250-1421</b>	3.70	94	4.76	121	1.38	35	<b>V250-1421</b>
35	1.3/8	1.7/8	1.1/2	-2230	2		2.3/8	60	<b>V000-24</b>	<b>6250-2230</b>	5.16	131	6.46	164	1.97	50	<b>V250-2230</b>

**NOTE:** Hose Compatibility for the **V000** series can be found on page 323.

INTRODUCTION

HOSE

COUPLINGS

ADAPTORS

TECHNICAL



# COUPLINGS

## V000 SERIES FIELD ATTACHABLE COUPLINGS

<b>JSEAL™ / JIC</b>	<b>V000 FERRULE</b>	<b>6240 INSERT</b>	<b>V240 COUPLING</b>
---------------------	---------------------	--------------------	----------------------

CONVEX SEAT

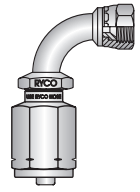
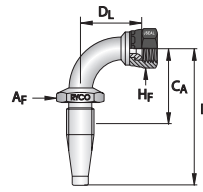
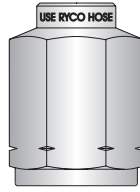

DN	inch	inch	inch	DASH SIZE	BACK UP Af		FEMALE HEX		PART NO	PART NO	JSEAL™ / JIC FEMALE 90° TUBE BEND						PART NO
					inch	mm	inch	mm			CA		L		DL		
5	3/16	7/16	1/4	-0307	5/8	16	9/16		V000-04	6240-0307	1.30	33	2.09	53	1.26	32	V240-0307
6	1/4	7/16	1/4	-0407	5/8	16	9/16		V000-05	6240-0407	1.50	38	2.56	65	1.06	27	V240-0407
6	1/4	1/2	5/16	-0408	5/8	16	5/8	16	V000-05	6240-0408	1.54	39	2.60	66	1.14	29	V240-0408
6	1/4	9/16	3/8	-0409	5/8	16	11/16		V000-05	6240-0409	1.42	36	2.48	63	1.14	29	V240-0409
8	5/16	9/16	3/8	-0509	5/8	16	11/16		V000-06	6240-0509	1.77	45	2.83	72	1.18	30	V240-0509
10	3/8	9/16	3/8	-0609	11/16		11/16		V000-08	6240-0609	1.73	44	3.03	77	0.98	25	V240-0609
10	3/8	3/4	1/2	-0612	11/16		7/8	22	V000-08	6240-0612	1.73	44	3.03	77	1.18	30	V240-0612
12	1/2	3/4	1/2	-0812	13/16		7/8	22	V000-10	6240-0812	2.13	54	3.43	87	1.50	38	V240-0812
12	1/2	7/8	5/8	-0814	13/16		1.1/16	27	V000-10	6240-0814	2.13	54	3.43	87	1.85	47	V240-0814
16	5/8	7/8	5/8	-1014	1		1.1/16	27	V000-12	6240-1014	2.36	60	3.78	96	1.89	48	V240-1014
16	5/8	1.1/16	3/4	-1017	1		1.1/4	32	V000-12	6240-1017	2.44	62	3.86	98	1.93	49	V240-1017
22	7/8	1.5/16	1	-1421	1.3/8		1.1/2	38	V000-16	6240-1421	3.03	77	4.09	104	2.83	72	V240-1421
28	1.1/18	1.5/8	1.1/4	-1826	1.3/4		2	50	V000-20	6240-1826	4.06	103	5.31	135	3.19	81	V240-1826
35	1.3/8	1.7/8	1.1/2	-2230	2		2.3/8	60	V000-24	6240-2230	4.45	113	5.75	146	4.09	104	V240-2230

<b>JSEAL™ / JIC</b>	<b>V000 FERRULE</b>	<b>6280 INSERT</b>	<b>V280 COUPLING</b>
---------------------	---------------------	--------------------	----------------------

CONVEX SEAT

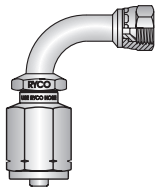
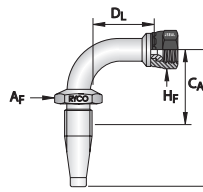
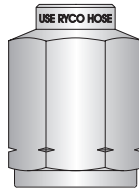

DN	inch	inch	inch	DASH SIZE	BACK UP Af		FEMALE HEX		PART NO	PART NO	JSEAL™ / JIC FEMALE 90° LONG TUBE BEND						PART NO
					inch	mm	inch	mm			CA		L		DL		
6	1/4	7/16	1/4	-0407	5/8	16	9/16		V000-05	6280-0407	1.54	39	2.60	66	1.85	47	V280-0407
6	1/4	1/2	5/16	-0408	5/8	16	5/8	16	V000-05	6280-0408	1.54	39	2.60	66	1.85	47	V280-0408
6	1/4	9/16	3/8	-0409	5/8	16	11/16		V000-05	6280-0409	1.54	39	2.60	66	2.13	54	V280-0409
8	5/16	9/16	3/8	-0509	5/8	16	11/16		V000-06	6280-0509	1.89	48	2.95	75	2.17	55	V280-0509
10	3/8	9/16	3/8	-0609	11/16		11/16		V000-08	6280-0609	1.61	41	2.91	74	2.17	55	V280-0609
10	3/8	3/4	1/2	-0612	11/16		7/8	22	V000-08	6280-0612	1.73	44	3.03	77	2.52	64	V280-0612
12	1/2	3/4	1/2	-0812	13/16		7/8	22	V000-10	6280-0812	2.09	53	3.39	86	2.44	62	V280-0812
12	1/2	7/8	5/8	-0814	13/16		1.1/16	27	V000-10	6280-0814	2.09	53	3.39	86	2.76	70	V280-0814
16	5/8	1.1/16	3/4	-1017	1		1.1/4	32	V000-12	6280-1017	2.44	62	3.86	98	3.78	96	V280-1017

**NOTE:** Hose Compatibility for the V000 series can be found on page 323.

## V000 SERIES FIELD ATTACHABLE COUPLINGS

<b>ORFS</b>	<b>V000 FERRULE</b>	<b>6800 INSERT</b>	<b>V800 COUPLING</b>
-------------	---------------------	--------------------	----------------------

O RING FACE SEAL

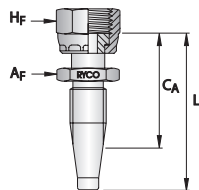
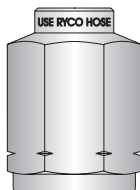

HOSE SIZE										ORFS FEMALE					
ACTUAL ID	THRD SIZE	TUBE SIZE	DASH SIZE	BACK UP Af	FEMALE HEX										
DN	inch	inch	inch		Af-SPANNER	Hf-SPANNER	PART NO	PART NO	CA	L	PART NO				
					inch	mm	inch	mm	inch	mm	inch	mm			
5	3/16	9/16	1/4	-0309	5/8	16	11/16		V000-04	6800-0309	1.26	32	2.05	52	V800-0309
6	1/4	9/16	1/4	-0409	5/8	16	11/16		V000-05	6800-0409	1.50	38	2.52	64	V800-0409
6	1/4	11/16	3/8	-0411	11/16			22	V000-05	6800-0411	1.57	40	2.60	66	V800-0411
8	5/16	11/16	3/8	-0511	5/8	16		22	V000-06	6800-0511	1.46	37	2.56	65	V800-0511
10	3/8	11/16	3/8	-0611	11/16			22	V000-08	6800-0611	1.42	36	2.76	70	V800-0611
10	3/8	13/16	1/2	-0613	13/16		15/16		V000-08	6800-0613	1.57	40	2.87	73	V800-0613
12	1/2	13/16	1/2	-0813	13/16		15/16		V000-10	6800-0813	1.61	41	2.91	74	V800-0813
12	1/2	1	5/8	-0816	15/16	24	1.1/8		V000-10	6800-0816	1.85	47	3.11	79	V800-0816
16	5/8	1	5/8	-1016	1.1/8		1.1/8		V000-12	6800-1016	1.93	49	3.35	85	V800-1016
16	5/8	1.3/16	3/4	-1019	1.1/8		1.3/8		V000-12	6800-1019	2.05	52	3.46	88	V800-1019
22	7/8	1.7/16	1	-1423	1.3/8		1.5/8	41	V000-16	6800-1423	2.32	59	3.39	86	V800-1423

<b>ORFS</b>	<b>V000 FERRULE</b>	<b>6810 INSERT</b>	<b>V810 COUPLING</b>
-------------	---------------------	--------------------	----------------------

O RING FACE SEAL

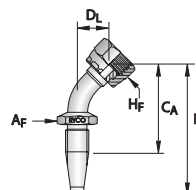
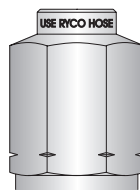

HOSE SIZE										ORFS FEMALE 45° TUBE BEND							
ACTUAL ID	THRD SIZE	TUBE SIZE	DASH SIZE	BACK UP Af	FEMALE HEX												
DN	inch	inch	inch		Af-SPANNER	Hf-SPANNER	PART NO	PART NO	CA	L	DL	PART NO					
					inch	mm	inch	mm	inch	mm	inch	mm					
5	3/16	9/16	1/4	-0309	5/8	16	11/16		V000-04	6810-0309	1.81	46	2.60	66	0.71	18	V810-0309
6	1/4	9/16	1/4	-0409	5/8	16	11/16		V000-05	6810-0409	2.01	51	3.07	78	0.71	18	V810-0409
6	1/4	11/16	3/8	-0411	5/8	16		22	V000-05	6810-0411	2.01	51	3.07	78	0.75	19	V810-0411
8	5/16	11/16	3/8	-0511	5/8	16		22	V000-06	6810-0511	2.13	54	3.23	82	0.79	20	V810-0511
10	3/8	11/16	3/8	-0611	11/16			22	V000-08	6810-0611	2.09	53	3.43	87	0.79	20	V810-0611
10	3/8	13/16	1/2	-0613	3/4	19	15/16		V000-08	6810-0613	1.93	49	3.23	82	0.67	17	V810-0613
12	1/2	13/16	1/2	-0813	13/16		15/16		V000-10	6810-0813	2.36	60	3.66	93	0.75	19	V810-0813
12	1/2	1	5/8	-0816	15/16	24	1.1/8		V000-10	6810-0816	2.36	60	3.66	93	0.75	19	V810-0816
16	5/8	1	5/8	-1016	1		1.1/8		V000-12	6810-1016	2.87	73	4.29	109	0.79	20	V810-1016
16	5/8	1.3/16	3/4	-1019	1.1/8		1.3/8		V000-12	6810-1019	2.87	73	4.29	109	0.94	24	V810-1019
22	7/8	1.7/16	1	-1423	1.3/8		1.5/8	41	V000-16	6810-1423	3.74	95	4.80	122	1.34	34	V810-1423

**NOTE:** Hose Compatibility for the V000 series can be found on page 323.

# COUPLINGS

## V000 SERIES FIELD ATTACHABLE COUPLINGS

<b>ORFS</b>	<b>V000 FERRULE</b>	<b>6820 INSERT</b>	<b>V820 COUPLING</b>
-------------	-------------------------	------------------------	--------------------------

O RING FACE SEAL

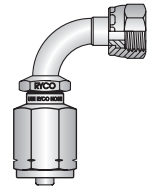
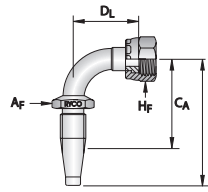
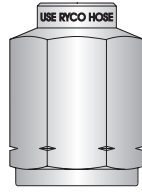

HOSE SIZE										ORFS FEMALE 90° TUBE BEND							
ACTUAL ID	THRD SIZE	TUBE SIZE	DASH SIZE	BACK UP Af	FEMALE HEX		PART NO		PART NO		CA		L		DL		PART NO
DN	inch	inch	inch		Af-SPANNER		Hf-SPANNER		PART NO	PART NO	inch	mm	inch	mm	inch	mm	PART NO
5	3/16	9/16	1/4	-0309	5/8	16	11/16		V000-04	6820-0309	1.38	35	2.17	55	1.26	32	V820-0309
6	1/4	9/16	1/4	-0409	5/8	16	11/16		V000-05	6820-0409	1.57	40	2.64	67	1.26	32	V820-0409
6	1/4	11/16	3/8	-0411	5/8	16	7/8	22	V000-05	6820-0411	1.57	40	2.64	67	1.50	38	V820-0411
8	5/16	11/16	3/8	-0511	5/8	16	7/8	22	V000-06	6820-0511	1.73	44	2.80	71	1.46	37	V820-0511
10	3/8	11/16	3/8	-0611	11/16		7/8	22	V000-08	6820-0611	1.69	43	2.99	76	1.50	38	V820-0611
10	3/8	13/16	1/2	-0613	3/4	19	15/16		V000-08	6820-0613	1.69	43	2.99	76	1.61	41	V820-0613
12	1/2	13/16	1/2	-0813	13/16		15/16		V000-10	6820-0813	2.05	52	3.35	85	1.61	41	V820-0813
12	1/2	1	5/8	-0816	15/16	24	1.1/8		V000-10	6820-0816	2.17	55	3.46	88	1.85	47	V820-0816
16	5/8	1	5/8	-1016	1		1.1/8		V000-12	6820-1016	2.40	61	3.82	97	1.85	47	V820-1016
16	5/8	1.3/16	3/4	-1019	1.1/8		1.3/8		V000-12	6820-1019	2.52	64	3.94	100	2.28	58	V820-1019
22	7/8	1.7/16	1	-1423	1.3/8			41	V000-16	6820-1423	3.11	79	4.17	106	2.80	71	V820-1423

<b>ORFS</b>	<b>V000 FERRULE</b>	<b>6830 INSERT</b>	<b>V830 COUPLING</b>
-------------	-------------------------	------------------------	--------------------------

O RING FACE SEAL

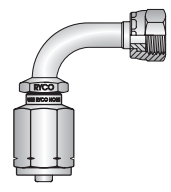
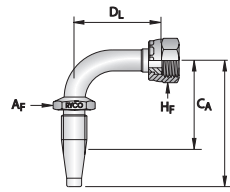
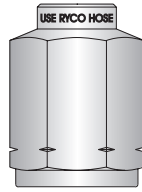

HOSE SIZE										ORFS FEMALE 90° LONG TUBE BEND							
ACTUAL ID	THRD SIZE	TUBE SIZE	DASH SIZE	BACK UP Af	FEMALE HEX		PART NO		PART NO		CA		L		DL		PART NO
DN	inch	inch	inch		Af-SPANNER		Hf-SPANNER		PART NO	PART NO	inch	mm	inch	mm	inch	mm	PART NO
5	3/16	9/16	1/4	-0309	5/8	16	11/16		V000-04	6830-0309	1.38	35	2.20	56	1.85	47	V830-0309
6	1/4	9/16	1/4	-0409	5/8	16	11/16		V000-05	6830-0409	1.61	41	2.64	67	1.85	47	V830-0409
6	1/4	11/16	3/8	-0411	5/8	16	7/8	22	V000-05	6830-0411	1.57	40	2.64	67	2.13	54	V830-0411
8	5/16	11/16	3/8	-0511	5/8	16	7/8	22	V000-06	6830-0511	1.61	41	2.72	69	2.13	54	V830-0511
10	3/8	11/16	3/8	-0611	11/16	18	7/8	22	V000-08	6830-0611	1.61	41	2.91	74	2.13	54	V830-0611
10	3/8	13/16	1/2	-0613	3/4	19	15/16		V000-08	6830-0613	1.61	41	2.91	74	2.52	64	V830-0613
12	1/2	13/16	1/2	-0813	13/16		15/16		V000-10	6830-0813	2.09	53	3.39	86	2.56	65	V830-0813
12	1/2	1	5/8	-0816	15/16	24	1.1/8		V000-10	6830-0816	2.28	58	3.58	91	2.76	70	V830-0816
16	5/8	1	5/8	-1016	1		1.1/8		V000-12	6830-1016	2.56	65	3.98	101	2.76	70	V830-1016
16	5/8	1.3/16	3/4	-1019	1.1/8		1.3/8		V000-12	6830-1019	2.48	63	3.90	99	3.78	96	V830-1019
22	7/8	1.7/16	1	-1423	1.3/8		1.5/8	41	V000-16	6830-1423	3.43	87	4.49	114	4.45	113	V830-1423

**NOTE:** Hose Compatibility for the V000 series can be found on page 323.

## V000 SERIES FIELD ATTACHABLE COUPLINGS

<b>SAE</b>	<b>V000 FERRULE</b>	<b>6530 INSERT</b>	<b>V530 COUPLING</b>
------------	---------------------	--------------------	----------------------

45° FLARE

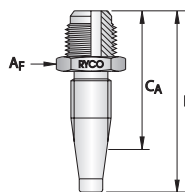
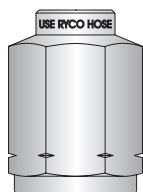

HOSE SIZE					BACK UP		SAE MALE						
ACTUAL ID	THRD SIZE	TUBE SIZE	DASH SIZE	Af		PART NO		Ca		L		PART NO	
DN	inch	inch	inch	inch	mm	inch	mm	inch	mm	inch	mm		
6	1/4	5/8	3/8	-0410	11/16		<b>V000-05</b>	<b>6530-0410</b>	1.46	37	2.48	63	<b>V530-0410</b>
8	5/16	5/8	3/8	-0510	5/8	16	<b>V000-06</b>	<b>6530-0510</b>	1.34	34	2.40	61	<b>V530-0510</b>
10	3/8	1/2	5/16	-0608	5/8	16	<b>V000-08</b>	<b>6530-0608</b>	1.26	32	2.56	65	<b>V530-0608</b>
10	3/8	5/8	3/8	-0610	3/4	19	<b>V000-08</b>	<b>6530-0610</b>	1.30	33	2.60	66	<b>V530-0610</b>

<b>SAE</b>	<b>V000 FERRULE</b>	<b>6540 INSERT</b>	<b>V540 COUPLING</b>
------------	---------------------	--------------------	----------------------

45° FLARE

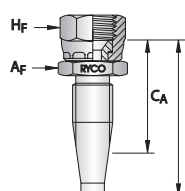
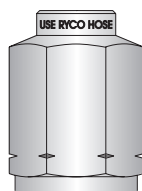

HOSE SIZE					BACK UP		FEMALE HEX		SAE FEMALE						
ACTUAL ID	THRD SIZE	TUBE SIZE	DASH SIZE	Af		Hf		PART NO		Ca		L		PART NO	
DN	inch	inch	inch	inch	mm	inch	mm	inch	mm	inch	mm	inch	mm		
5	3/16	7/16	1/4	-0307	5/8	16	9/16		<b>V000-04</b>	<b>6540-0307</b>	0.91	23	1.73	44	<b>V540-0307</b>
6	1/4	7/16	1/4	-0407	11/16		9/16		<b>V000-05</b>	<b>6540-0407</b>	1.14	29	2.17	55	<b>V540-0407</b>
6	1/4	1/2	5/16	-0408	11/16		5/8	16	<b>V000-05</b>	<b>6540-0408</b>	1.14	29	2.17	55	<b>V540-0408</b>
8	5/16	5/8	3/8	-0510	11/16		3/4	19	<b>V000-06</b>	<b>6540-0510</b>	1.06	27	2.13	54	<b>V540-0510</b>
10	3/8	5/8	3/8	-0610	3/4	19	3/4	19	<b>V000-08</b>	<b>6540-0610</b>	1.02	26	2.36	60	<b>V540-0610</b>
10	3/8	3/4	1/2	-0612	7/8	22	7/8	22	<b>V000-08</b>	<b>6540-0612</b>	1.14	29	2.44	62	<b>V540-0612</b>
12	1/2	7/8	5/8	-0814	1		1.1/16	27	<b>V000-10</b>	<b>6540-0814</b>	1.30	33	2.60	66	<b>V540-0814</b>
16	5/8	1.1/16	3/4	-1017	1.1/8		1.1/4	32	<b>V000-12</b>	<b>6540-1017</b>	1.50	38	2.91	74	<b>V540-1017</b>

**NOTE:** Hose Compatibility for the **V000** series can be found on page 323.

# COUPLINGS

## V000 SERIES FIELD ATTACHABLE COUPLINGS

<b>SAE</b>	<b>V000 FERRULE</b>	<b>6550 INSERT</b>	<b>V550 COUPLING</b>
------------	-------------------------	------------------------	--------------------------

45° FLARE

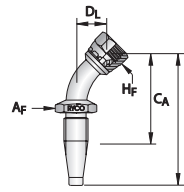
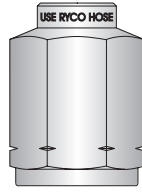

HOSE SIZE					BACK UP		FEMALE		SAE FEMALE 45° TUBE BEND								
ACTUAL ID	THRD SIZE	TUBE SIZE	DASH SIZE	AF	AF	HEX	PART NO		CA		L		DL		PART NO		
DN	inch	inch	inch		inch	mm	inch	mm	inch	mm	inch	mm	inch	mm			
5	3/16	7/16	1/4	-0307	5/8	16	9/16		<b>V000-04</b>	<b>6550-0307</b>	1.57	40	2.36	60	0.59	15	<b>V550-0307</b>
8	5/16	5/8	3/8	-0510	5/8	16	3/4	19	<b>V000-06</b>	<b>6550-0510</b>	2.01	51	3.07	78	0.67	17	<b>V550-0510</b>
10	3/8	1/2	5/16	-0608	11/16		5/8	16	<b>V000-08</b>	<b>6550-0608</b>	1.89	48	3.23	82	0.59	15	<b>V550-0608</b>
10	3/8	5/8	3/8	-0610	11/16		3/4	19	<b>V000-08</b>	<b>6550-0610</b>	1.97	50	3.27	83	0.67	17	<b>V550-0610</b>

<b>SAE</b>	<b>V000 FERRULE</b>	<b>6560 INSERT</b>	<b>V560 COUPLING</b>
------------	-------------------------	------------------------	--------------------------

45° FLARE

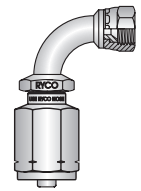
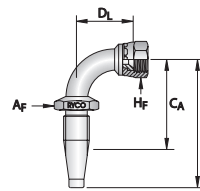
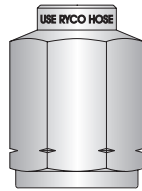

HOSE SIZE					BACK UP		FEMALE		SAE FEMALE 90° TUBE BEND								
ACTUAL ID	THRD SIZE	TUBE SIZE	DASH SIZE	AF	AF	HEX	PART NO		CA		L		DL		PART NO		
DN	inch	inch	inch		inch	mm	inch	mm	inch	mm	inch	mm	inch	mm			
5	3/16	7/16	1/4	-0307	5/8	16	9/16		<b>V000-04</b>	<b>6560-0307</b>	1.30	33	2.13	54	1.14	29	<b>V560-0307</b>
8	5/16	5/8	3/8	-0510	5/8	16	3/4	19	<b>V000-06</b>	<b>6560-0510</b>	1.73	44	2.80	71	1.30	33	<b>V560-0510</b>
10	3/8	5/8	3/8	-0610	11/16		3/4	19	<b>V000-08</b>	<b>6560-0610</b>	1.69	43	2.99	76	1.30	33	<b>V560-0610</b>

<b>SAE</b>	<b>V000 FERRULE</b>	<b>6740 INSERT</b>	<b>V740 COUPLING</b>
------------	-------------------------	------------------------	--------------------------

INVERTED  
MALE FLARE

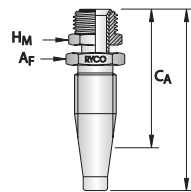
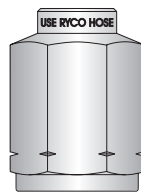

HOSE SIZE					BACK UP		MALE		SAE INVERTED MALE FLARE						
ACTUAL ID	THRD SIZE	TUBE SIZE	DASH SIZE	AF	AF	HEX	PART NO		CA		L		PART NO		
DN	inch	inch	inch		inch	mm	inch	mm	inch	mm	inch	mm			
6	1/4	7/16	1/4	-0407	5/8	16	5/8	16	<b>V000-05</b>	<b>6740-0407</b>	1.97	50	3.03	77	<b>V740-0407</b>
8	5/16	5/8	3/8	-0510	5/8	16	5/8	16	<b>V000-06</b>	<b>6740-0510</b>	1.89	48	2.95	75	<b>V740-0510</b>
10	3/8	5/8	3/8	-0610	11/16		11/16		<b>V000-08</b>	<b>6740-0610</b>	1.85	47	3.15	80	<b>V740-0610</b>
10	3/8	11/16	7/16	-0611	11/16		11/16		<b>V000-08</b>	<b>6740-0611</b>	1.97	50	3.31	84	<b>V740-0611</b>

**NOTE:** Hose Compatibility for the **V000** series can be found on page 339.

## V000 SERIES FIELD ATTACHABLE COUPLINGS

SAE					V000 FERRULE	6750 INSERT	V750 COUPLING
-----	--	--	--	--	-----------------	----------------	------------------

INVERTED  
MALE FLARE

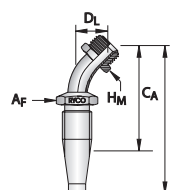
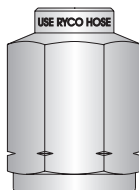

HOSE SIZE ACTUAL ID	THRD SIZE	TUBE SIZE	DASH SIZE	BACK UP AF	MALE HEX	SAE INVERTED MALE FLARE 45° TUBE BEND									
------------------------	--------------	--------------	--------------	---------------	-------------	--	--	--	--	--	--	--	--	--	--

DN	inch	inch	inch	DASH	AF-SPANNER		HM-SPANNER		PART NO	PART NO	CA		L		DL		PART NO
					inch	mm	inch	mm			inch	mm	inch	mm	inch	mm	
8	5/16	5/8	3/8	-0510	5/8	16	5/8	16	V000-06	6750-0510	3.15	80	4.21	107	0.91	23	V750-0510
10	3/8	5/8	3/8	-0610	11/16		11/16		V000-08	6750-0610	3.11	79	4.45	113	0.91	23	V750-0610

SAE					V000 FERRULE	6770 INSERT	V770 COUPLING
-----	--	--	--	--	-----------------	----------------	------------------

INVERTED  
MALE FLARE

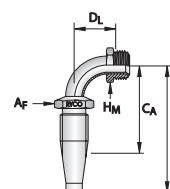
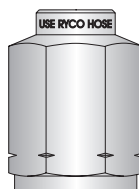

HOSE SIZE ACTUAL ID	THRD SIZE	TUBE SIZE	DASH SIZE	BACK UP AF	MALE HEX	SAE INVERTED MALE FLARE 90° TUBE BEND									
------------------------	--------------	--------------	--------------	---------------	-------------	--	--	--	--	--	--	--	--	--	--

DN	inch	inch	inch	DASH	AF-SPANNER		HM-SPANNER		PART NO	PART NO	CA		L		DL		PART NO
					inch	mm	inch	mm			inch	mm	inch	mm	inch	mm	
6	1/4	7/16	1/4	-0407	5/8	16	5/8	16	V000-05	6770-0407	2.05	52	3.07	78	1.50	38	V770-0407
8	5/16	5/8	3/8	-0510	5/8	16	5/8	16	V000-06	6770-0510	2.44	62	3.50	89	1.97	50	V770-0510
10	3/8	5/8	3/8	-0610	11/16		11/16		V000-08	6770-0610	2.40	61	3.70	94	1.97	50	V770-0610

**NOTE:** Hose Compatibility for the V000 series can be found on page 339.

# COUPLINGS

## V000 SERIES FIELD ATTACHABLE COUPLINGS

<b>SALVAGE</b>	<b>V000 FERRULE</b>	<b>6230 INSERT</b>	<b>V230 COUPLING</b>
----------------	-------------------------	------------------------	--------------------------

TUBE WELD

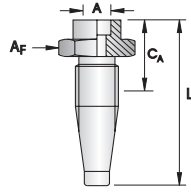
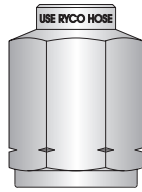

HOSE SIZE ACTUAL ID		A	DASH SIZE	BACK UP Af	SALVAGE (LIFESAVER)							
DN	inch	inch		Af-SPANNER		PART NO	PART NO	CA		L		PART NO
				inch	mm			inch	mm	inch	mm	
5	3/16	1/4	-0304	5/8	16	V000-04	6230-0304					V230-0304
6	1/4	3/8	-0506	5/8	16	V000-05	6230-0406	1.10	28	2.13	54	V230-0406
8	5/16	3/8	-0606	5/8	16	V000-06	6230-0506	0.98	25	2.09	53	V230-0506
10	3/8	3/8	-0608	11/16		V000-08	6230-0606	0.94	24	2.28	58	V230-0606
10	3/8	1/2	-0810	11/16		V000-08	6230-0608	0.94	24	2.28	58	V230-0608
12	1/2	5/8	-1012	7/8	22	V000-10	6230-0810	1.14	29	2.44	62	V230-0810
16	5/8	3/4	-1416	1		V000-12	6230-1012	1.22	31	2.64	67	V230-1012
22	7/8	1	-1820	1.3/8		V000-16	6230-1416	1.26	32	2.36	60	V230-1416
28	1.1/8	1.1/4	-2224	1.43/50		V000-20	6230-1820	1.61	41	2.91	74	V230-1820
35	1.3/8	1.1/2	-2224	2		V000-24	6230-2224	1.34	34	2.64	67	V230-2224

<b>UNO (O RING BOSS)</b>	<b>V000 FERRULE</b>	<b>6200 INSERT</b>	<b>V200 COUPLING</b>
--------------------------	-------------------------	------------------------	--------------------------

O RING SUPPLIED

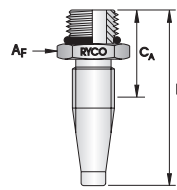
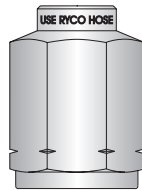

HOSE SIZE ACTUAL ID		THRD SIZE	TUBE SIZE	DASH SIZE	BACK UP Af	UN O RING MALE (O RING BOSS)							
DN	inch	inch	inch		Af-SPANNER		PART NO	PART NO	CA		L		PART NO
					inch	mm			inch	mm	inch	mm	
6	1/4	9/16	3/8	-0409	11/16		V000-05	6200-0409	1.22	31	2.24	57	V200-0409
10	3/8	9/16	3/8	-0609	3/4	19	V000-08	6200-0609	1.06	27	2.40	61	V200-0609
10	3/8	3/4	1/2	-0612	7/8	22	V000-08	6200-0612	1.18	30	2.52	64	V200-0612
12	1/2	3/4	1/2	-0812	7/8	22	V000-10	6200-0812	1.30	33	2.60	66	V200-0812
12	1/2	7/8	5/8	-0814	1		V000-10	6200-0814	1.38	35	2.68	68	V200-0814
12	1/2	1.1/16	3/4	-0817	1.1/4	32	V000-10	6200-0817	1.54	39	2.83	72	V200-0817
16	5/8	1.1/16	3/4	-1017	1.1/4	32	V000-12	6200-1017	1.61	41	3.03	77	V200-1017

**NOTE:** Hose Compatibility for the V000 series can be found on page 339.



# FIELD ATTACHABLE FERRULES FOR 6000 SERIES INSERTS

## HOSE COMPATIBILITY FOR 6000 SERIES

### FIELD ATTACHABLE FERRULES FOR 6000 SERIES INSERTS

The RYCO Field Attachable system consists of five ferrule styles, each specific to a hose type, and one common insert. Field attachable inserts and ferrules can be ordered individually, or as a complete coupling for specific hose types. Field Attachable Inserts for RYCO Hose Series T1D, T2D, TXA2D, RQP1, RQP2, RQP5, T1F, M2, M2G, BT1, E1, E2, T5. For **V000** Series for RQP5 and T5 Hose Series, see pages 341 to 352. **6000** Series Inserts are used with NON-SKIVE Ferrules **K000**, **L000**, **M000**, **P000** and **V000** Series.

INTRODUCTION

HOSE

COUPLINGS

ADAPTORS

TECHNICAL

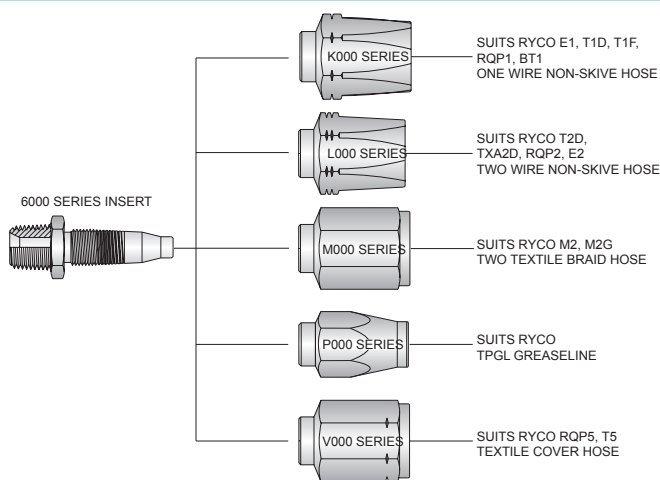

V000 Series Couplings for T5 Hose Series are shown on pages 341 to 352. 6000 Series Inserts, for use with **K000**, **L000**, **M000** and **P000** Series Ferrules, are shown on pages 355 to 385

FERRULES	K000	L000	M000	P000
----------	------	------	------	------

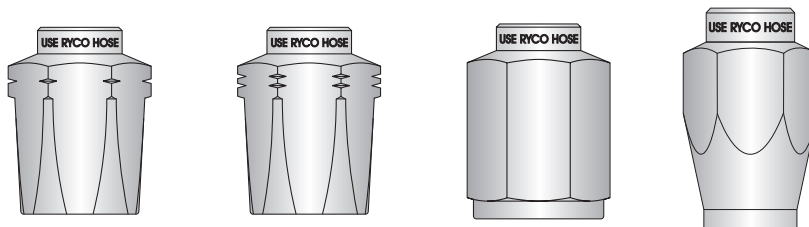

SUITS RYCO HOSE TYPE			ONE WIRE BRAID NON-SKIVE	TWO WIRE BRAID NON-SKIVE	TWO TEXTILE BRAID	GREASELINE					
SUITS RYCO HOSE SERIES			RYCO T1D, T1F, RQP1, BT1	RYCO T2D, TXA2D, RQP2, E2	RYCO M2, M2G	RYCO TPGL					
HOSE SIZE		USE INSERT	CA ADJ	CA ADJ	CA ADJ	CA ADJ					
DN	inch	Dash	Series	Part No	mm	Part No	mm	Part No	mm	Part No	mm
	1/8	-02	<b>6000-02</b>							<b>P000-02</b>	0
5	3/16	-03	<b>6000-03</b>								
6	1/4	-04	<b>6000-04</b>	<b>K000-04</b>	0	<b>L000-04</b>	0	<b>M000-04</b>	0		
10	3/8	-06	<b>6000-06</b>	<b>K000-06</b>	0	<b>L000-06</b>	0	<b>M000-06</b>	0		
12	1/2	-08	<b>6000-08</b>	<b>K000-08</b>	+3	<b>L000-08</b>	0	<b>M000-08</b>	0		
16	5/8	-10	<b>6000-10</b>	<b>K000-10</b>	+1	<b>L000-10</b>	0				
19	3/4	-12	<b>6000-12</b>	<b>K000-12</b>	+2	<b>L000-12</b>	0	<b>M000-12</b>	0		
25	1	-16	<b>6000-16</b>	<b>K000-16</b>	0	<b>L000-16</b>	0	<b>M000-16</b>	-2		
31	1.1/4	-20	<b>6000-20</b>			<b>L000-20</b>	0				
38	1.1/2	-24	<b>6000-24</b>								
51	2	-32	<b>6000-32</b>								

**NOTE:** For previous Part Number series, remove a zero from the end of the new series Part Number. Eg, **K000** series was previously **K00** series. Part Number **L000-04** was previously **L00-04**. The exception is **M000**, which was previously the **400** series.

# COUPLINGS

## HOW TO ORDER RYCO FIELD ATTACHABLE COUPLINGS

### ALL SERIES (EXCEPT V SERIES)

Field Attachable Inserts and Ferrules can be ordered individually, or as complete Couplings. Each Ferrule Series is specific to a hose type as detailed on the previous page. For all Series, except V Series\*, the following method is used:

- EXAMPLE 1** To order 1/2" NPT male Insert and Ferrule for 1/2" two wire non-skive hose (T2D).
- (a) Individually Order Insert **6090-0808** (6000 Series). See NPT 6000 Series Inserts on page 360.  
Order Ferrule **L000-08**.  
L000 Series Ferrules are used on T2D hose; see table on the previous page, or table for Matched Couplings for T2D on page 101.  
Dash Size -08 part of **L000-08** comes from 1/2" hose = 8/16" = -08; or from the tables.
- (b) Complete Coupling Order **L090-0808**.  
Simply replace the first character of the Insert part number with the first character of the Ferrule part number.  
(replace 6 with L) = **6090-0808** »» **L090-0808**

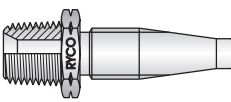
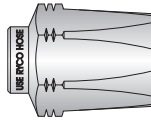
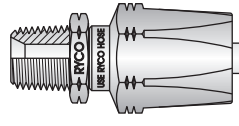
6090-0808 Insert	plus L000-08 Ferrule equals	L090-0808 complete Coupling
		

- EXAMPLE 2** To order 3/4"-16 JIC female Insert and Ferrule for 3/8" RQP1 series hose.
- (a) Individually Order Insert **6040-0612** (6000 Series). See JIC 6000 Series Inserts on page 364.  
Order Ferrule **K000-06**.  
K000 Series Ferrules are used on RQP1 hose; see table on previous page, table for Matched Couplings for RQP1 on page 111.  
Dash Size -06 part of **K000-06** comes from 3/8" hose = 6/16" = -06; or from the tables.
- (b) Complete Coupling Order **K040-0612**.  
Simply replace the first character of the Insert part number with the first character of the Ferrule part number.  
(replace 6 with K) = **6040-0612** »» **K040-0612**

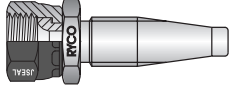
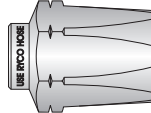
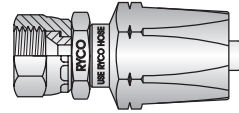
6040-0612 Insert	plus K000-06 Ferrule equals	K040-0612 complete Coupling
		

\* See page 340 for How To Order RYCO V000 Series Field Attachable Couplings for RQP5 and T5 Series Hose.

### CUT-OFF ALLOWANCE (CA) DIMENSIONS FOR FIELD ATTACHABLES

Due to differences in Ferrule design, many Cut-Off Allowance (CA) dimensions vary between each Ferrule Series for the same matched Insert/Hose size.

The Cut-Off Allowance (CA) dimensions published in "6000 Series Field Attachable Inserts" section allow for the Ferrule being eased back 5/8 of a turn after the hose has bottomed in the ferrule, as per "Field Attachable Assembly Instructions" (ease back between 1/2 and 3/4 of a turn).

The Cut-Off Allowance (CA) values for 6000 Series Inserts, published in the tables on pages 355 to 385 are:  
Up to and including -20 Size; the CA is for **L000** Series (the most popular series)

To determine the correct Cut-Off Allowance (CA) for other Ferrule Series, use the published figure from pages 355 to 385, and adjust by the CA Adjustment dimension listed in the table on the previous page.

- EXAMPLE:** Determine the Cut-Off Allowance (CA) for **K090-0808**.  
From table on page 108, Cut-Off Allowance (CA) for **6090-0808** (L090-0808) is 42 mm.  
From the table on the previous page, adjustment for **K000** Series in -08 size is "add 3 mm".  
**Cut-Off Allowance (CA) for K090-0808 = 42 mm + 3 mm = 45 mm.**

If the hose assembly length is critical, when calculating the Cut Length of hose, you must also allow for an increase in length of hose when the coupling is attached, due to compression within the coupling; see page 466.

For further information about Hose Assemblies and Cut-Off Allowances (CA), see pages 466 to 471 of the Technical Section.

\* For Cut-Off Allowances (CA), and **V Series** Couplings, refer to pages 341 to 354.

## 6000 SERIES FIELD ATTACHABLE INSERTS

<b>BSPT</b>	<b>6010</b>	<b>6020</b>
-------------	-------------	-------------

**60° SEAT**

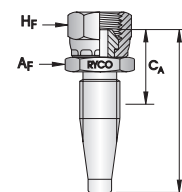
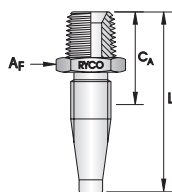

HOSE SIZE		THRD SIZE	DASH SIZE	BACK UP Af		FEMALE HEX		BSPT MALE				BSPT FEMALE					
DN	inch	inch		Af-SPANNER		Hf-SPANNER		PART NO	CA		L		PART NO	CA		L	
				inch	mm	inch	mm		inch	mm	inch	mm		inch	mm	inch	mm
4	1/8	1/8	-0202	7/16	11	7/16	11	<b>6010-0202</b>	1.02	26	1.65	42	<b>6020-0202</b>	1.02	26	1.61	41
5	3/16	1/8	-0302	5/8	16	5/8	16						<b>6020-0302</b>	0.98	25	1.81	46
6	1/4	1/8	-0402	5/8	16	5/8	16	<b>6010-0402</b>	1.22	31	2.24	57	<b>6020-0402</b>	1.22	31	2.24	57
6	1/4	1/4	-0404	5/8	16	11/16		<b>6010-0404</b>	1.38	35	2.44	62	<b>6020-0404</b>	1.22	31	2.28	58
6	1/4	3/8	-0406	11/16		11/16		<b>6010-0406</b>	1.38	35	2.44	62	<b>6020-0406</b>	1.30	33	2.36	60
8	5/16	1/4	-0504	5/8	16	5/8	16	<b>6010-0504</b>	1.30	33	2.36	60	<b>6020-0504</b>	1.14	29	2.20	56
8	5/16	3/8	-0506	11/16		11/16		<b>6010-0506</b>	1.30	33	2.36	60	<b>6020-0506</b>	1.30	33	2.36	60
10	3/8	1/8	-0606	11/16				<b>6010-0602</b>	1.10	28	2.40	61					
10	3/8	1/4	-0604	11/16		11/16		<b>6010-0604</b>	1.26	32	2.60	66	<b>6020-0604</b>	1.10	28	2.40	61
10	3/8	3/8	-0606	11/16		13/16		<b>6010-0606</b>	1.26	32	2.60	66	<b>6020-0606</b>	1.22	31	2.56	65
10	3/8	1/2	-0608	7/8	22	7/8	22	<b>6010-0608</b>	1.54	39	2.83	72	<b>6020-0608</b>	1.30	33	2.60	66
12	1/2	1/4	-0804	13/16				<b>6010-0804</b>	1.46	37	2.76	70					
12	1/2	3/8	-0806	13/16		13/16		<b>6010-0806</b>	1.46	37	2.76	70	<b>6020-0806</b>	1.34	34	2.64	67
12	1/2	1/2	-0808	7/8	22	1		<b>6010-0808</b>	1.65	42	2.91	74	<b>6020-0808</b>	1.42	36	2.72	69
12	1/2	3/4	-0812	1		1							<b>6020-0812</b>	1.42	36	2.72	69
16	5/8	1/2	-1008	1.1/8				<b>6010-1008</b>	1.77	45	3.19	81					
16	5/8	5/8	-1010	1.1/8		1.1/8		<b>6010-1010</b>	1.77	45	3.19	81	<b>6020-1010</b>	1.50	38	2.91	74
16	5/8	3/4	-1012	1.1/8		1.1/8		<b>6010-1012</b>	1.77	45	3.19	81	<b>6020-1012</b>	1.57	40	2.99	76
19	3/4	3/4	-1212	1.1/16	27	1.1/4	32	<b>6010-1212</b>	1.65	42	3.15	80	<b>6020-1212</b>	1.50	38	2.99	76
19	3/4	1	-1216	1.3/8		1.1/2	38	<b>6010-1216</b>	1.97	50	3.46	88	<b>6020-1216</b>	1.65	42	3.11	79
22	7/8	1	-1416	1.1/2	38	1.1/2	38						<b>6020-1416</b>	1.57	40	2.64	67
25	1	1	-1616	1.3/8		1.1/2	38	<b>6010-1616</b>	2.17	55	3.66	93	<b>6020-1616</b>	1.81	46	3.35	85
28	1.1/8	1.1/4	-1820					<b>6010-1820</b>	2.28	58	3.54	90	<b>6020-1820</b>	2.01	51	3.31	84
31	1.1/4	1.1/4	-2020					<b>6010-2020</b>	2.36	60	4.49	114	<b>6020-2020</b>	2.13	54	4.21	107
38	1.1/2	1.1/2	-2424	2.1/4	57	2.1/4	57	<b>6010-2424</b>	2.24	57	4.72	120	<b>6020-2424</b>	2.01	51	4.49	114
51	2	2	-3232	2.1/2		2.3/4	70	<b>6010-3232</b>	2.60	66	5.39	137	<b>6020-3232</b>	2.44	62	5.24	133

**NOTE:** Hose Compatibility for the **6000** series can be found on page 353.

INTRODUCTION

HOSE

COUPLINGS

ADAPTORS

TECHNICAL

# COUPLINGS

## 6000 SERIES FIELD ATTACHABLE INSERTS

BSPT

6320

60° SEAT

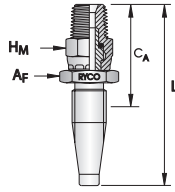

HOSE SIZE		THRD SIZE	DASH SIZE	BACK UP AF		MALE HEX		BSPT MALE SWIVEL				
DN	inch	inch		AF-SPANNER		HM-SPANNER		PART NO	C <sub>A</sub>		L	
	inch	inch		inch	mm	inch	mm		inch	mm	inch	mm
4	1/8	1/8	-0202	1/2		1/2		6320-0202	1.18	30	1.81	46
10	3/8	3/8	-0606	7/8	22	7/8	22	6320-0606	2.01	51	3.35	85
10	3/8	1/2	-0608	7/8	22	7/8	22	6320-0608	2.20	56	3.50	89
12	1/2	1/2	-0808	7/8	22	7/8	22	6320-0808	2.32	59	3.62	92
19	3/4	3/4	-1212	1.1/8		1.1/8		6320-1212	2.32	59	3.82	97

**NOTE:** The "Live Swivel" 6320 Series Insert is for Maximum Working Pressure: 420 bar (6100 psi): -04 & -06 Thread Size, 350 bar (5100 psi): -08 Thread Size, 280 bar (4100 psi): -12 Thread Size, 215 bar (3100 psi): -16 Thread Size. The swivel capability is to allow easy installation and orientation and avoid twisting of hose. They are not designed for continuous rotation or continuous movement.

BSPT

6340

60° SEAT

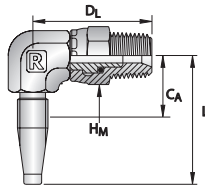

HOSE SIZE		THRD SIZE	DASH SIZE	BACK UP AF		BSPT MALE SWIVEL 90° ELBOW						
DN	inch	inch		AF-SPANNER		PART NO	C <sub>A</sub>		L		D <sub>L</sub>	
	inch	inch		inch	mm		inch	mm	inch	mm	inch	mm
10	3/8	3/8	-0606	3/4	19	6340-0606	0.98	25	2.28	58	1.77	45
10	3/8	1/2	-0608	3/4	19	6340-0608	0.98	25	2.28	58	1.97	50
12	1/2	1/2	-0808	7/8	22	6340-0808	1.26	32	2.56	65	2.05	52

**NOTE:** The "Live Swivel" 6340 Series Insert is for Maximum Working Pressure: 420 bar (6100 psi): -04 & -06 Thread Size, 350 bar (5100 psi): -08 Thread Size, 280 bar (4100 psi): -12 Thread Size, 215 bar (3100 psi): -16 Thread Size. Their swivel capability is to allow easy installation and orientation and avoid twisting of hose. They are not designed for continuous rotation or continuous movement.

**NOTE:** Hose Compatibility for the 6000 series can be found on page 353.

## 6000 SERIES FIELD ATTACHABLE INSERTS

<b>BSPP</b>	<b>6024</b>	<b>6052</b>
-------------	-------------	-------------

**SPECIAL SEATS**

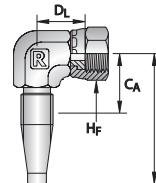
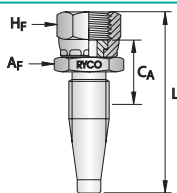

HOSE SIZE		THRD SIZE	DASH SIZE	BACK UP Af	FEMALE HEX	BSPP FEMALE FLAT FACE						BSPP FEMALE FLAT FACE 90° ELBOW								
DN	inch	inch		Af-SPANNER		Hf-SPANNER		PART NO	CA		L		PART NO	CA		L		DL		
				inch	mm	inch	mm		inch	mm	inch	mm		inch	mm	inch	mm	inch	mm	inch
6	1/4	1/4	-0404	11/16		3/4	19	<b>6024-0404</b>	1.14	29	2.20	56								
10	3/8	3/8	-0606	13/16		7/8	22	<b>6024-0606</b>	1.14	29	2.44	62								
10	3/8	1/2	-0608	7/8	22	1.1/16	27	<b>6024-0608</b>	1.14	29	2.44	62	<b>6052-0608</b>	1.02	26	2.32	59	0.94	24	
12	1/2	1/2	-0808	1		1.1/16	27	<b>6024-0808</b>	1.26	32	2.56	65								
12	1/2	3/4	-0812	1		1.1/4	32	<b>6024-0812</b>	1.34	34	2.64	67								
19	3/4	3/4	-1212	1.1/4	32	1.1/4	32	<b>6024-1212</b>	1.42	36	2.87	73								

<b>BSPP</b>	<b>6060</b>
-------------	-------------

**60° SEAT**

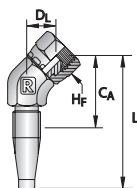

HOSE SIZE		THRD SIZE	DASH SIZE	FEMALE HEX	BSPP FEMALE 45° ELBOW									
DN	inch	inch		Hf-SPANNER		PART NO	CA		L		DL			
				inch	mm		inch	mm	inch	mm	inch	mm		
6	1/4	1/4	-0404	3/4	19	<b>6060-0404</b>	1.61	41	2.68	68	0.59	15		
10	3/8	3/8	-0606	7/8	22	<b>6060-0606</b>	1.65	42	2.95	75	0.67	17		
12	1/2	1/2	-0808	1.1/16	27	<b>6060-0808</b>	1.97	50	3.27	83	0.71	18		
16	5/8	5/8	-1010	1.3/16	30	<b>6060-1010</b>	1.97	50	3.39	86	0.67	17		
19	3/4	3/4	-1212	1.1/4	32	<b>6060-1212</b>	1.97	50	3.43	87	0.79	20		
25	1	1	-1616	1.1/2	38	<b>6060-1616</b>	2.36	60	3.90	99	0.83	21		
31	1.1/4	1.1/4	-2020	2	50	<b>6060-2020</b>	2.56	65	4.69	119	0.98	25		

**NOTE:** Hose Compatibility for the **6000** series can be found on page 353.

INTRODUCTION

HOSE

COUPLINGS

ADAPTORS

TECHNICAL

# COUPLINGS

## 6000 SERIES FIELD ATTACHABLE INSERTS

**BSPP**

**6050**

**60° SEAT**

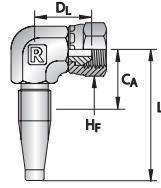

HOSE SIZE		THRD SIZE	DASH SIZE	FEMALE HEX		PART NO	BSPP FEMALE 90° ELBOW					
DN	inch	inch		inch	mm		CA		L		DL	
							inch	mm	inch	mm	inch	mm
6	1/4	1/4	-0404	3/4	19	<b>6050-0404</b>	1.06	27	2.09	53	0.94	24
6	1/4	3/8	-0406	7/8	22	<b>6050-0406</b>	1.06	27	2.13	54	1.10	28
10	3/8	3/8	-0606	7/8	22	<b>6050-0606</b>	0.98	25	2.28	58	1.10	28
10	3/8	1/2	-0608	1.1/16	27	<b>6050-0608</b>	1.02	26	2.32	59	1.22	31
12	1/2	1/2	-0808	1.1/16	27	<b>6050-0808</b>	1.26	32	2.56	65	1.22	31
16	5/8	5/8	-1010	1.3/16	30	<b>6050-1010</b>	1.34	34	2.76	70	1.18	30
19	3/4	3/4	-1212	1.1/4	32	<b>6050-1212</b>	1.26	32	2.72	69	1.38	35
25	1	1	-1616	1.1/2	38	<b>6050-1616</b>	1.61	41	3.15	80	1.57	40
31	1.1/4	1.1/4	-2020	2	50	<b>6050-2020</b>	2.36	60	4.49	114	1.85	47
38	1.1/2	1.1/2	-2424	2.3/16	55	<b>6050-2424</b>	2.17	55	4.65	118	2.36	60
51	2	2	-3232	2.3/4	70	<b>6050-3232</b>	2.20	56	5.00	127	2.44	62

**BSPP**

**6270**

**6260**

**60° SEAT**

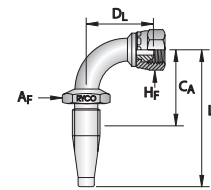
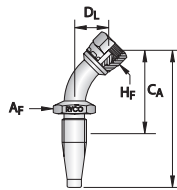

HOSE SIZE		THRD SIZE	DASH SIZE	BACK UP Af		FEMALE HEX		PART NO	BSPP FEMALE 45° TUBE BEND				BSPP FEMALE 90° TUBE BEND									
DN	inch	inch		inch	mm	inch	mm		CA		L		DL		PART NO		CA		L		DL	
									inch	mm	inch	mm	inch	mm			inch	mm	inch	mm	inch	mm
6	1/4	1/4	-0404	5/8	16	3/4	19	<b>6270-0404</b>	1.85	47	2.87	73	0.67	17	<b>6260-0404</b>	1.54	39	2.60	66	1.14	29	
8	5/16	3/8	-0506	5/8	16	7/8	22	<b>6270-0506</b>	2.09	53	3.19	81	0.75	19	<b>6260-0506</b>	1.73	44	2.80	71	1.34	34	
10	3/8	3/8	-0606	11/16		7/8	22	<b>6270-0606</b>	2.05	52	3.35	85	0.71	18	<b>6260-0606</b>	1.73	44	3.03	77	1.30	33	
12	1/2	1/2	-0608	13/16		1.1/16	27		2.44	62	3.74	95	0.87	22	<b>6260-0608</b>	1.73	44	3.03	77	1.30	33	
12	1/2	1/2	-0808	13/16		1.1/16	27	<b>6270-0808</b>	2.72	69	4.13	105	0.91	23	<b>6260-0808</b>	2.09	53	3.39	86	1.69	43	
12	1/2	5/8	-0810	13/16		1.3/16	30		3.23	82	4.69	119	1.14	29	<b>6260-0810</b>	2.13	54	3.43	87	1.77	45	
16	5/8	5/8	-1010	1		1.3/16	30	<b>6270-1010</b>	4.25	108	5.79	147	1.54	39	<b>6260-1010</b>	2.48	63	3.90	99	2.01	51	
19	3/4	3/4	-1212	1.1/16	27	1.1/4	32	<b>6270-1212</b>	4.80	122	6.93	176	1.73	44	<b>6260-1212</b>	2.68	68	4.13	105	2.28	58	
25	1	1	-1616	1.3/8		1.1/2	38	<b>6270-1616</b>	5.20	132	6.50	165	2.13	54	<b>6260-1616</b>	3.27	83	4.80	122	2.87	73	
31	1.1/4	1.1/4	-2020	1.3/4		2	50	<b>6270-2020</b>	6.50	165	9.25	235	2.56	65	<b>6260-2020</b>	4.17	106	6.30	160	3.46	88	
35	1.3/8	1.1/2	-2224	2		2.3/16	55	<b>6270-2224</b>	5.20	132	6.50	165	2.13	54	<b>6260-2224</b>	4.45	113	5.75	146	4.17	106	
51	2	2	-3232	2.1/2		2.3/4	70	<b>6270-3232</b>	6.50	165	9.25	235	2.56	65	<b>6260-3232</b>	5.98	152	8.74	222	5.20	132	

**NOTE:** Hose Compatibility for the **6000** series can be found on page 353.

## 6000 SERIES FIELD ATTACHABLE INSERTS

<b>BSPP</b>	<b>6210</b>
-------------	-------------

60° SEAT

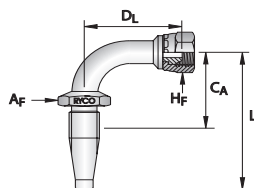

HOSE SIZE		THRD SIZE	DASH SIZE	BACK UP Af		FEMALE HEX		BSPP FEMALE 90° LONG TUBE BEND						
DN	inch	inch		inch	mm	inch	mm	PART NO	CA		L		DL	
									inch	mm	inch	mm	inch	mm
6	1/4	1/4	-0404	5/8	16	3/4	19	<b>6210-0404</b>	1.54	39	2.60	66	1.85	47
10	3/8	3/8	-0606	11/16		7/8	22	<b>6210-0606</b>	1.69	43	2.99	76	2.17	55
12	1/2	1/2	-0808	13/16		1.1/16	27	<b>6210-0808</b>	2.05	52	3.35	85	2.76	70
16	5/8	5/8	-1010	1		1.3/16	30	<b>6210-1010</b>	2.36	60	3.78	96	3.19	81
19	3/4	3/4	-1212	1.1/16	27	1.1/4	32	<b>6210-1212</b>	2.68	68	4.13	105	3.78	96
25	1	1	-1616	1.3/8		1.1/2	38	<b>6210-1616</b>	3.27	83	4.80	122	4.29	109
31	1.1/4	1.1/4	-2020	1.3/4		2	50	<b>6210-2020</b>	4.17	106	6.30	160	5.59	142

<b>BSP</b>	<b>6860</b>	<b>6861</b>
------------	-------------	-------------

60° SEAT

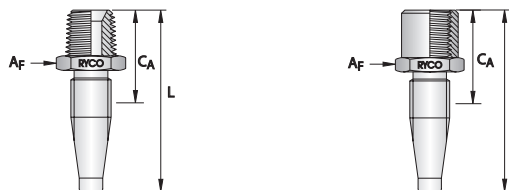

HOSE SIZE		THRD SIZE	DASH SIZE	BACK UP Af		GREASE LINE MALE				GREASE LINE FIXED FEMALE								
DN	inch	inch		inch	mm	PART NO		CA		L		PART NO		CA		L		
						inch	mm	inch	mm	inch	mm	inch	mm	inch	mm	inch	mm	
6	1/4	1/2x27 TPI	-0408	11/16		<b>6860-0408</b>	1.38	35	2.44	62	<b>6861-0408</b>	1.26	32	2.32	59			
10	3/8	1/2x27 TPI	-0608	3/4	19							<b>6861-0608</b>	1.14	29	2.44	62		

**NOTE:** Hose Compatibility for the **6000** series can be found on page 353.

INTRODUCTION

HOSE

COUPLINGS

ADAPTORS

TECHNICAL



# COUPLINGS

## 6000 SERIES FIELD ATTACHABLE INSERTS

<b>NPT</b>	<b>6090</b>
------------	-------------

60° SEAT

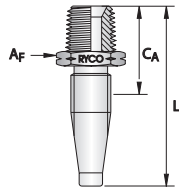

HOSE SIZE		THRD SIZE	DASH SIZE	BACK UP Af		NPT MALE				
DN	inch	inch		AF-SPANNER		PART NO	CA		L	
				inch	mm		inch	mm	inch	mm
4	1/8	1/8	-0202	5/8	16	<b>6090-0202</b>	1.02	26	1.65	42
5	3/16	1/8	-0302	7/16	11	<b>6090-0302</b>	0.98	25	1.81	46
5	3/16	1/4	-0304	5/8	16	<b>6090-0304</b>	1.18	30	1.97	50
6	1/4	1/8	-0402	7/16	11	<b>6090-0402</b>	1.22	31	2.24	57
6	1/4	1/4	-0404	5/8	16	<b>6090-0404</b>	1.38	35	2.44	62
6	1/4	3/8	-0406	11/16		<b>6090-0406</b>	1.38	35	2.44	62
8	5/16	1/4	-0504	5/8	16	<b>6090-0504</b>	1.30	33	2.36	60
8	5/16	3/8	-0506	11/16		<b>6090-0506</b>	1.38	35	2.44	62
10	3/8	1/4	-0604	11/16		<b>6090-0604</b>	1.26	32	2.60	66
10	3/8	3/8	-0606	11/16		<b>6090-0606</b>	1.26	32	2.60	66
10	3/8	1/2	-0608	7/8	22	<b>6090-0608</b>	1.54	39	2.83	72
12	1/2	3/8	-0806	7/8	22	<b>6090-0806</b>	1.46	37	2.76	70
12	1/2	1/2	-0808	7/8	22	<b>6090-0808</b>	1.65	42	2.91	74
16	5/8	1/2	-1008	1.1/8		<b>6090-1008</b>	1.77	45	3.19	81
16	5/8	3/4	-1012	1.1/8		<b>6090-1012</b>	1.77	45	3.19	81
19	3/4	1/2	-1208	1.1/8		<b>6090-1208</b>	1.65	42	3.15	80
19	3/4	3/4	-1212	1.1/16	27	<b>6090-1212</b>	1.65	42	3.15	80
22	7/8	1	-1416	1.3/8		<b>6090-1416</b>	1.89	48	2.99	76
25	1	1	-1616	1.3/8		<b>6090-1616</b>	2.17	55	3.66	93
28	1.1/8	1.1/4	-1820			<b>6090-1820</b>	2.28	58	3.54	90
31	1.1/4	1.1/4	-2020			<b>6090-2020</b>	2.36	60	4.49	114
35	1.3/8	1.1/2	-2224	2		<b>6090-2224</b>	2.01	51	3.31	84
38	1.1/2	1.1/2	-2424	2.1/4	57	<b>6090-2424</b>	2.24	57	4.72	120
51	2	2	-3232	2.1/2		<b>6090-3232</b>	2.60	66	5.39	137

<b>NPT</b>	<b>6091</b>
------------	-------------

60° SEAT

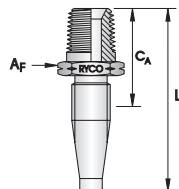

HOSE SIZE		THRD SIZE	DASH SIZE	BACK UP Af		NPT MALE EXTENDED				
DN	inch	inch		AF-SPANNER		PART NO	CA		L	
				inch	mm		inch	mm	inch	mm
6	1/4	3/8	-0406	3/4	19	<b>6091-0406</b>	1.69	43	2.76	70
10	3/8	3/8	-0606	3/4	19	<b>6091-0606</b>	1.57	40	2.87	73

**NOTE:** Hose Compatibility for the **6000** series can be found on page 353.

## 6000 SERIES FIELD ATTACHABLE INSERTS

### NPSM 6960B

60° SEAT

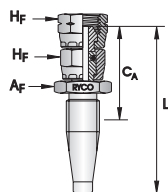

HOSE SIZE		THRD SIZE	DASH SIZE	BACK UP AF	FEMALE HEX		NPSM FEMALE LIVE SWIVEL						
DN	inch	inch		AF-SPANNER		HF-SPANNER		PART NO		CA		L	
	inch	inch		inch	mm	inch	mm		inch	mm	inch	mm	
6	1/4	1/4	-0404	11/16		11/16		<b>6960B-0404</b>	1.42	36	2.48	63	
10	3/8	1/4	-0604	11/16		11/16		<b>6960B-0604</b>	1.30	33	2.60	66	

### GREASELINE BSPT 6010

60° SEAT  
FOR TPGL HOSE

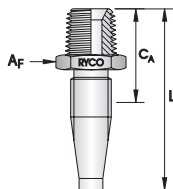

HOSE SIZE		THRD SIZE	DASH SIZE	BACK UP AF	MALE HEX		BSPT MALE						
DN	inch	inch		AF-SPANNER		HM-SPANNER		PART NO		CA		L	
	inch	inch		inch	mm	inch	mm		inch	mm	inch	mm	
4	1/8	1/8	-0202	7/16	11	7/16	11	<b>6010-0202</b>	1.02	26	1.65	42	

### GREASELINE BSPT 6320

60° SEAT  
FOR TPGL HOSE

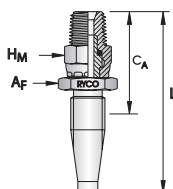

HOSE SIZE		THRD SIZE	DASH SIZE	BACK UP AF	MALE HEX		BSPT MALE SWIVEL						
DN	inch	inch		AF-SPANNER		HM-SPANNER		PART NO		CA		L	
	inch	inch		inch	mm	inch	mm		inch	mm	inch	mm	
4	1/8	1/8	-0202	1/2		1/2		<b>6320-0202</b>	1.18	30	1.81	46	

**NOTE:** For use with TPGL2 and P000-02. These "Live Swivel" 6320 Series Inserts are for Maximum Working Pressure: 420 bar (6100 psi) -02 Hose Size.

**NOTE:** Hose Compatibility for the 6000 series can be found on page 353.

INTRODUCTION

HOSE

COUPLINGS

ADAPTORS

TECHNICAL

# COUPLINGS

## 6000 SERIES FIELD ATTACHABLE INSERTS

### GREASELINE NPTF

6090

60° SEAT  
FOR TPGL HOSE

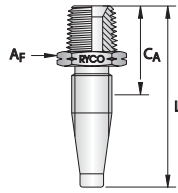

HOSE SIZE		THRD SIZE	DASH SIZE	BACK UP AF		NPTF MALE					
DN	inch	inch		AF-SPANNER		PART NO	CA		L		
				inch	mm		inch	mm	inch	mm	
4	1/8	1/8	-0202	5/8	16	6090-0202	1.02	26	1.65	42	

### GREASELINE NPTF

6320N

60° SEAT  
FOR TPGL HOSE

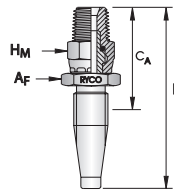

HOSE SIZE		THRD SIZE	DASH SIZE	BACK UP AF		MALE HEX		NPTF MALE SWIVEL				
DN	inch	inch		AF-SPANNER		HM1-SPANNER		PART NO	CA		L	
				inch	mm	inch	mm		inch	mm	inch	mm
4	1/8	1/8	-0202	1/2		1/2		6320N-0202	1.18	30	1.81	46

**NOTE:** For use with TPGL2 and P000-02. These "Live Swivel" 6320 Series Inserts are for Maximum Working Pressure: 420 bar (6100 psi) -02 Hose Size.

### GREASELINE JSEAL™ / JIC

6040

CONVEX SEAT  
FOR TPGL HOSE

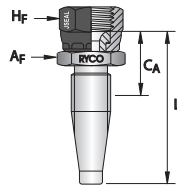

HOSE SIZE		THRD SIZE	DASH SIZE	BACK UP AF		FEMALE HEX		JSEAL™ / JIC FEMALE				
DN	inch	inch		AF-SPANNER		HF-SPANNER		PART NO	CA		L	
				inch	mm	inch	mm		inch	mm	inch	mm
4	1/8	7/16	-0207	7/16	11	9/16		6040-0207	0.94	24	1.57	40

**NOTE:** Hose Compatibility for the 6000 series can be found on page 353.

## 6000 SERIES FIELD ATTACHABLE INSERTS

<b>JIC - MALE</b>	<b>6030</b>
-------------------	-------------

**37° FLARE**

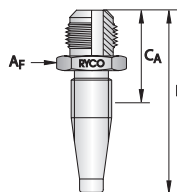

HOSE SIZE		THRD SIZE	TUBE SIZE	DASH SIZE	BACK UP Af		JIC MALE					
DN	inch	inch	inch		Af-SPANNER		PART NO	CA		L		
					inch	mm		inch	mm	inch	mm	
4	1/8	7/16	1/4	-0207	1/2		<b>6030-0207</b>	1.26	32	1.89	48	
5	3/16	7/16	1/4	-0307	5/8	16	<b>6030-0307</b>	1.14	29	1.97	50	
6	1/4	7/16	1/4	-0407	5/8	16	<b>6030-0407</b>	1.38	35	2.40	61	
6	1/4	1/2	5/16	-0408	5/8	16	<b>6030-0408</b>	1.38	35	2.40	61	
6	1/4	9/16	3/8	-0409	5/8	16	<b>6030-0409</b>	1.38	35	2.44	62	
6	1/4	3/4	1/2	-0412	13/16		<b>6030-0412</b>	1.54	39	2.60	66	
10	3/8	9/16	3/8	-0609	11/16		<b>6030-0609</b>	1.26	32	2.56	65	
10	3/8	3/4	1/2	-0612	13/16		<b>6030-0612</b>	1.42	36	2.72	69	
10	3/8	7/8	5/8	-0614	1		<b>6030-0614</b>	1.50	38	2.83	72	
12	1/2	3/4	1/2	-0812	13/16		<b>6030-0812</b>	1.54	39	2.83	72	
12	1/2	7/8	5/8	-0814	15/16	24	<b>6030-0814</b>	1.61	41	2.91	74	
12	1/2	1.1/16	3/4	-0817	1.1/8		<b>6030-0817</b>	1.81	46	3.07	78	
16	5/8	7/8	5/8	-1014	1.1/8		<b>6030-1014</b>	1.77	45	3.19	81	
16	5/8	1.1/16	3/4	-1017	1.1/8		<b>6030-1017</b>	1.89	48	3.31	84	
19	3/4	1.1/16	3/4	-1217	1.1/8		<b>6030-1217</b>	1.81	46	3.31	84	
19	3/4	1.3/16	7/8	-1219	1.1/4	32	<b>6030-1219</b>	1.85	47	3.31	84	
19	3/4	1.5/16	1	-1221	1.3/8		<b>6030-1221</b>	1.93	49	3.43	87	
25	1	1.1/16	3/4	-1617	1.3/8		<b>6030-1617</b>	2.05	52	3.58	91	
25	1	1.5/16	1	-1621	1.3/8		<b>6030-1621</b>	2.09	53	3.62	92	
31	1.1/4	1.5/8	1.1/4	-2026	1.3/4		<b>6030-2026</b>	2.36	60	4.49	114	

**NOTE:** Hose Compatibility for the **6000** series can be found on page 353.

INTRODUCTION

HOSE

COUPLINGS

ADAPTORS

TECHNICAL

# COUPLINGS

## 6000 SERIES FIELD ATTACHABLE INSERTS

JSEAL™ / JIC

6040

CONVEX SEAT

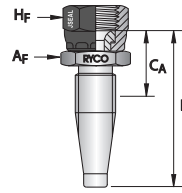

HOSE SIZE		THRD SIZE	TUBE SIZE	DASH SIZE	BACK UP Af		FEMALE HEX		JSEAL™ / JIC FEMALE	CA		L	
DN	inch	inch	inch		Af-SPANNER		Hf-SPANNER		PART NO	inch	mm	inch	mm
4	1/8	7/16	1/4	-0207	7/16	11	9/16		6040-0207	0.94	24	1.57	40
5	3/16	7/16	1/4	-0307	9/16		9/16		6040-0307	0.91	23	1.73	44
6	1/4	5/16	1/8	-0405					6040-0405				
6	1/4	3/8	3/16	-0406	1/2		1/2		6040-0406	1.26	32	2.28	58
6	1/4	7/16	1/4	-0407	5/8	16	9/16		6040-0407	1.14	29	2.17	55
6	1/4	1/2	5/16	-0408	5/8	16	5/8	16	6040-0408	1.14	29	2.17	55
6	1/4	9/16	3/8	-0409	11/16		11/16		6040-0409	1.14	29	2.20	56
6	1/4	3/4	1/2	-0412	3/4	19	7/8	22	6040-0412	1.22	31	2.24	57
8	5/16	9/16	3/8	-0509	11/16		11/16		6040-0509	1.06	27	2.13	54
10	3/8	7/16	1/4	-0607	11/16		9/16		6040-0607	1.02	26	2.32	59
10	3/8	1/2	5/16	-0608	11/16		5/8	16	6040-0608	1.02	26	2.32	59
10	3/8	9/16	3/8	-0609	11/16		11/16		6040-0609	0.87	22	2.17	55
10	3/8	3/4	1/2	-0612	7/8	22	7/8	22	6040-0612	1.14	29	2.44	62
10	3/8	7/8	5/8	-0614	1		1.1/16	27	6040-0614	1.30	33	2.60	66
12	1/2	9/16	3/8	-0809	13/16		11/16		6040-0809	1.22	31	2.52	64
12	1/2	3/4	1/2	-0812	7/8	22	7/8	22	6040-0812	1.26	32	2.56	65
12	1/2	7/8	5/8	-0814	1		1.1/16	27	6040-0814	1.54	39	2.80	71
12	1/2	1.1/16	3/4	-0817	1.1/8		1.1/4	32	6040-0817	1.50	38	2.80	71
16	5/8	7/8	5/8	-1014	1		1.1/16	27	6040-1014	1.50	38	2.91	74
16	5/8	1.1/16	3/4	-1017	1.1/4	32	1.1/4	32	6040-1017	1.57	40	2.99	76
19	3/4	7/8	5/8	-1214	1.1/16	27	1.1/16	27	6040-1214	1.50	38	2.95	75
19	3/4	1.1/16	3/4	-1217	1.1/4	32	1.1/4	32	6040-1217	1.54	39	2.99	76
19	3/4	1.3/16	7/8	-1219	1.3/8		1.3/8		6040-1219	1.50	38	2.99	76
19	3/4	1.5/16	1	-1221	1.1/2	38	1.1/2	38	6040-1221	1.65	42	3.11	79
22	7/8	1.5/16	1	-1421	1.1/2	38	1.1/2	38	6040-1421	1.57	40	2.64	67
25	1	1.1/16	3/4	-1617	1.3/8		1.1/4	32	6040-1617	1.77	45	3.31	84
25	1	1.5/16	1	-1621	1.1/2	38	1.1/2	38	6040-1621	1.81	46	3.35	85
25	1	1.5/8	1.1/4	-1626	1.5/8	41	2	50	6040-1626	1.85	47	3.39	86
28	1.1/8	1.5/8	1.1/4	-1826			2	50	6040-1826	2.13	54	3.39	86
31	1.1/4	1.5/8	1.1/4	-2026			2	50	6040-2026	2.05	52	4.17	106
35	1.3/8	1.7/8	1.1/2	-2230	2		2.3/8	60	6040-2230	1.77	45	3.07	78
38	1.1/2	1.7/8	1.1/2	-2430	2.1/4	57	2.3/8	60	6040-2430	2.01	51	4.45	113
46	1.13/16	2.1/2	2	-2940	2.3/4	70	2.7/8	73	6040-2940	2.13	54	3.90	99
51	2	2.1/2	2	-3240	2.3/4	70	2.7/8	73	6040-3240	2.44	62	5.24	133

NOTE: \* 6040-0207 is for use with TPGL2 and P000-02

NOTE: Hose Compatibility for the 6000 series can be found on page 353.

## 6000 SERIES FIELD ATTACHABLE INSERTS

### JSEAL™ / JIC 6080

CONVEX SEAT

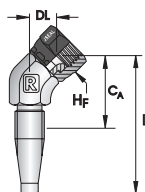

HOSE SIZE					THRD SIZE	TUBE SIZE	DASH SIZE	FEMALE HEX	JSEAL™ / JIC FEMALE 45° ELBOW					
DN	inch	inch	inch	inch	HF-SPANNER		PART NO	CA		L		DL		
					inch	mm		inch	mm	inch	mm	inch	mm	
6	1/4	7/16	1/4	-0407	9/16		<b>6080-0407</b>	1.46	37	2.52	64	0.43	11	
6	1/4	1/2	5/16	-0408	5/8	16	<b>6080-0408</b>	1.50	38	2.52	64	0.43	11	
6	1/4	9/16	3/8	-0409	11/16		<b>6080-0409</b>	1.57	40	2.60	66	0.51	13	
10	3/8	9/16	3/8	-0609	11/16		<b>6080-0609</b>	1.50	38	2.80	71	0.51	13	
10	3/8	3/4	1/2	-0612	7/8	22	<b>6080-0612</b>	1.57	40	2.87	73	0.59	15	
12	1/2	3/4	1/2	-0812	7/8	22	<b>6080-0812</b>	1.89	48	3.15	80	0.59	15	
12	1/2	7/8	5/8	-0814	1.1/16	27	<b>6080-0814</b>	1.93	49	3.23	82	0.67	17	
12	1/2	1.1/16	3/4	-0817	1.1/4	32	<b>6080-0817</b>	1.93	49	3.23	82	0.67	17	
16	5/8	7/8	5/8	-1014	1.1/16	27	<b>6080-1014</b>	1.93	49	3.35	85	0.63	16	
16	5/8	1.1/16	3/4	-1017	1.1/4	32	<b>6080-1017</b>	1.93	49	3.35	85	0.67	17	
19	3/4	1.1/16	3/4	-1217	1.1/4	32	<b>6080-1217</b>	1.85	47	3.31	84	0.67	17	
25	1	1.5/16	1	-1621	1.1/2	38	<b>6080-1621</b>	2.36	60	3.90	99	0.83	21	
31	1.1/4	1.5/8	1.1/4	-2026	2	50	<b>6080-2026</b>	2.64	67	4.72	120	0.98	25	

### JSEAL™ / JIC 6070

CONVEX SEAT

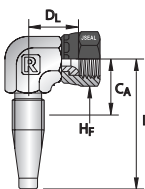

HOSE SIZE					THRD SIZE	TUBE SIZE	DASH SIZE	FEMALE HEX	JSEAL™ / JIC FEMALE 90° ELBOW					
DN	inch	inch	inch	inch	HF-SPANNER		PART NO	CA		L		DL		
					inch	mm		inch	mm	inch	mm	inch	mm	
6	1/4	7/16	1/4	-0407	9/16		<b>6070-0407</b>	1.46	37	2.52	64	0.43	11	
6	1/4	1/2	5/16	-0408	5/8	16	<b>6070-0408</b>	1.50	38	2.52	64	0.43	11	
6	1/4	9/16	3/8	-0409	11/16		<b>6070-0409</b>	1.57	40	2.60	66	0.51	13	
10	3/8	7/16	1/4	-0607	9/16		<b>6070-0607</b>	1.50	38	2.80	71	0.51	13	
10	3/8	9/16	3/8	-0609	11/16		<b>6070-0609</b>	1.57	40	2.87	73	0.59	15	
10	3/8	3/4	1/2	-0612	7/8	22	<b>6070-0612</b>	1.89	48	3.15	80	0.59	15	
12	1/2	3/4	1/2	-0812	7/8	22	<b>6070-0812</b>	1.93	49	3.23	82	0.67	17	
12	1/2	7/8	5/8	-0814	1.1/16	27	<b>6070-0814</b>	1.93	49	3.23	82	0.67	17	
12	1/2	1.1/16	3/4	-0817	1.1/4	32	<b>6070-0817</b>	1.93	49	3.35	85	0.63	16	
16	5/8	7/8	5/8	-1014	1.1/16	27	<b>6070-1014</b>	1.93	49	3.35	85	0.67	17	
16	5/8	1.1/16	3/4	-1017	1.1/4	32	<b>6070-1017</b>	1.85	47	3.31	84	0.67	17	
19	3/4	1.1/16	3/4	-1217	1.1/4	32	<b>6070-1217</b>	2.36	60	3.90	99	0.83	21	
19	3/4	1.3/16	7/8	-1219	1.3/8		<b>6070-1219</b>	2.64	67	4.72	120	0.98	25	
25	1	1.5/16	1	-1621	1.1/2	38	<b>6070-1621</b>	1.61	41	3.15	80	1.50	38	
31	1.1/4	1.5/8	1.1/4	-2026	2	50	<b>6070-2026</b>	2.36	60	4.49	114	1.89	48	

**NOTE:** Hose Compatibility for the 6000 series can be found on page 353.

INTRODUCTION

HOSE

COUPLINGS

ADAPTORS

TECHNICAL

# COUPLINGS

## 6000 SERIES FIELD ATTACHABLE INSERTS

JSEAL™ / JIC

6250

CONVEX SEAT

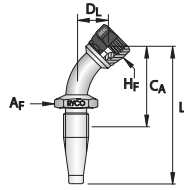

HOSE SIZE	THRD SIZE	TUBE SIZE	DASH SIZE	BACK UP AF		FEMALE HEX		JSEAL™ / JIC FEMALE 45° TUBE BEND							
				inch	mm	inch	mm	PART NO	CA		L		DL		
DN	inch	inch	inch		inch	mm	inch	mm		inch	mm	inch	mm	inch	mm
5	3/16	7/16	1/4	-0307	5/8	16	9/16		<b>6250-0307</b>	1.61	41	2.44	62	0.59	15
6	1/4	7/16	1/4	-0407	5/8	16	9/16		<b>6250-0407</b>	1.77	45	2.83	72	0.59	15
6	1/4	1/2	5/16	-0408	5/8	16	5/8	16	<b>6250-0408</b>	1.77	45	2.83	72	0.59	15
6	1/4	9/16	3/8	-0409	5/8	16	11/16		<b>6250-0409</b>	1.77	45	2.83	72	0.59	15
8	5/16	9/16	3/8	-0509	5/8	16	11/16		<b>6250-0509</b>	1.85	47	2.95	75	0.55	14
10	3/8	9/16	3/8	-0609	11/16		11/16		<b>6250-0609</b>	1.85	47	3.15	80	0.55	14
10	3/8	3/4	1/2	-0612	11/16		7/8	22	<b>6250-0612</b>	1.89	48	3.19	81	0.67	17
12	1/2	3/4	1/2	-0812	13/16		7/8	22	<b>6250-0812</b>	2.32	59	3.62	92	0.83	21
12	1/2	7/8	5/8	-0814	13/16		1.1/16	27	<b>6250-0814</b>	2.40	61	3.70	94	0.87	22
16	5/8	7/8	5/8	-1014	1		1.1/16	27	<b>6250-1014</b>	2.68	68	4.09	104	0.94	24
16	5/8	1.1/16	3/4	-1017	1		1.1/4	32	<b>6250-1017</b>	2.68	68	4.09	104	0.94	24
19	3/4	1.1/16	3/4	-1217	1.1/16	27	1.1/4	32	<b>6250-1217</b>	3.27	83	4.72	120	1.10	28
19	3/4	1.3/16	7/8	-1219			1.3/8		<b>6250-1219</b>	2.99	76	4.49	114	0.94	24
19	3/4	1.5/16	1	-1221	1.1/4	32	1.1/2	38	<b>6250-1221</b>	3.31	84	4.76	121	1.26	32
22	7/8	1.5/16	1	-1421	1.3/8		1.1/2	38	<b>6250-1421</b>	3.70	94	4.76	121	1.38	35
25	1	1.5/16	1	-1621	1.3/8		1.1/2	38	<b>6250-1621</b>	3.94	100	5.47	139	1.38	35
31	1.1/4	1.5/8	1.1/4	-2026	1.3/4		2	50	<b>6250-2026</b>	4.69	119	6.81	173	1.54	39
35	1.3/8	1.7/8	1.1/2	-2230	2		2.3/8	60	<b>6250-2230</b>	5.16	131	6.46	164	1.97	50

**NOTE:** Hose Compatibility for the **6000** series can be found on page 353.



## 6000 SERIES FIELD ATTACHABLE INSERTS

<b>JSEAL™ / JIC</b>	<b>6240</b>
---------------------	-------------

**CONVEX SEAT**

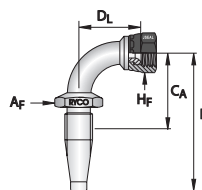

HOSE SIZE		THRD SIZE	TUBE SIZE	DASH SIZE	BACK UP AF		FEMALE HEX		JSEAL™ / JIC FEMALE 90° TUBE BEND						
DN	inch	inch	inch		AF-SPANNER		HF-SPANNER		PART NO	CA		L		DL	
					inch	mm	inch	mm		inch	mm	inch	mm	inch	mm
5	3/16	7/16	1/4	-0307	5/8	16	9/16		<b>6240-0307</b>	1.30	33	2.09	53	1.26	32
6	1/4	7/16	1/4	-0407	5/8	16	9/16		<b>6240-0407</b>	1.50	38	2.56	65	1.06	27
6	1/4	1/2	5/16	-0408	5/8	16	5/8	16	<b>6240-0408</b>	1.54	39	2.60	66	1.14	29
6	1/4	9/16	3/8	-0409	5/8	16	11/16		<b>6240-0409</b>	1.42	36	2.48	63	1.14	29
8	5/16	9/16	3/8	-0509	5/8	16	11/16		<b>6240-0509</b>	1.77	45	2.83	72	1.18	30
10	3/8	9/16	3/8	-0609	11/16		11/16		<b>6240-0609</b>	1.73	44	3.03	77	0.98	25
10	3/8	3/4	1/2	-0612	11/16		7/8	22	<b>6240-0612</b>	1.73	44	3.03	77	1.18	30
12	1/2	3/4	1/2	-0812	13/16		7/8	22	<b>6240-0812</b>	2.13	54	3.43	87	1.50	38
12	1/2	7/8	5/8	-0814	13/16		1.1/16	27	<b>6240-0814</b>	2.13	54	3.43	87	1.85	47
16	5/8	7/8	5/8	-1014	1		1.1/16	27	<b>6240-1014</b>	2.36	60	3.78	96	1.89	48
16	5/8	1.1/16	3/4	-1017	1		1.1/4	32	<b>6240-1017</b>	2.44	62	3.86	98	1.93	49
19	3/4	1.1/16	3/4	-1217	1.1/16	27	1.1/4	32	<b>6240-1217</b>	2.68	68	4.13	105	2.24	57
19	3/4	1.5/16	1	-1221	1.1/4	32	1.1/2	38	<b>6240-1221</b>	2.76	70	4.21	107	2.80	71
22	7/8	1.5/16	1	-1421	1.3/8		1.1/2	38	<b>6240-1421</b>	3.03	77	4.09	104	2.83	72
25	1	1.1/16	3/4	-1617	1.3/8		1.1/4	32	<b>6240-1617</b>	3.03	77	4.57	116	2.28	58
25	1	1.5/16	1	-1621	1.3/8		1.1/2	38	<b>6240-1621</b>	3.31	84	4.84	123	2.83	72
28	1.1/8	1.5/8	1.1/4	-1826	1.3/4		2	50	<b>6240-1826</b>	4.06	103	5.31	135	3.19	81
31	1.1/4	1.5/8	1.1/4	-2026	1.3/4		2	50	<b>6240-2026</b>	4.21	107	6.34	161	3.23	82
35	1.3/8	1.7/8	1.1/2	-2230	2		2.3/8	60	<b>6240-2230</b>	4.45	113	5.75	146	4.09	104

INTRODUCTION

HOSE

COUPLINGS

ADAPTORS

TECHNICAL

**NOTE:** Hose Compatibility for the **6000** series can be found on page 353.

# COUPLINGS

## 6000 SERIES FIELD ATTACHABLE INSERTS

JSEAL™ / JIC

6280

CONVEX SEAT

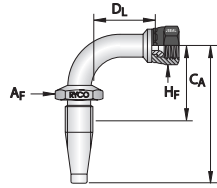

DN	HOSE SIZE			DASH SIZE	BACK UP AF		FEMALE HEX		PART NO	JSEAL™ / JIC FEMALE 90° LONG BEND		L		DL	
	inch	inch	inch		inch	mm	inch	mm		inch	mm	inch	mm	inch	mm
6	1/4	7/16	1/4	-0407	5/8	16	9/16		<b>6280-0407</b>	1.54	39	2.60	66	1.85	47
6	1/4	1/2	5/16	-0408	5/8	16	5/8	16	<b>6280-0408</b>	1.54	39	2.60	66	1.85	47
6	1/4	9/16	3/8	-0409	5/8	16	11/16		<b>6280-0409</b>	1.54	39	2.60	66	2.13	54
8	5/16	9/16	3/8	-0509	5/8	16	11/16		<b>6280-0509</b>	1.89	48	2.95	75	2.17	55
10	3/8	9/16	3/8	-0609	11/16	18	11/16		<b>6280-0609</b>	1.61	41	2.91	74	2.17	55
10	3/8	3/4	1/2	-0612	11/16	18	7/8	22	<b>6280-0612</b>	1.73	44	3.03	77	2.52	64
12	1/2	3/4	1/2	-0812	13/16		7/8	22	<b>6280-0812</b>	2.09	53	3.39	86	2.44	62
12	1/2	7/8	5/8	-0814	13/16		1.1/16	27	<b>6280-0814</b>	2.09	53	3.39	86	2.76	70
16	5/8	7/8	5/8	-1014	1		1.1/16	27	<b>6280-1014</b>	2.44	62	3.86	98	2.76	70
16	5/8	1.1/16	3/4	-1017	1		1.1/4	32	<b>6280-1017</b>	2.44	62	3.86	98	3.78	96
19	3/4	1.1/16	3/4	-1217	1.1/16	27	1.1/4	32	<b>6280-1217</b>	2.68	68	4.13	105	3.78	96
25	1	1.5/16	1	-1621	1.3/8		1.1/2	38	<b>6280-1621</b>	3.58	91	5.12	130	4.49	114
31	1.1/4	1.5/8	1.1/4	-2026	1.3/4		2	50	<b>6280-2026</b>	4.13	105	6.26	159	5.08	129
38	1.1/2	1.7/8	1.1/2	-2430	2.1/4	57	2.3/8	60	<b>6280-2430</b>	4.76	121	7.24	184	5.55	141

JIS - METRIC

6680

JAPANESE INDUSTRIAL STANDARD (JIS)  
METRIC THREAD FORM  
60° CONCAVE SEAT

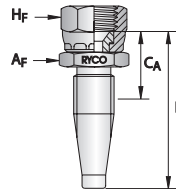

DN	HOSE SIZE			DASH SIZE	BACK UP AF		FEMALE HEX		PART NO	METRIC FEMALE 60° CONCAVE SEAT (JIS)		L	
	inch	mm	mm		inch	mm	inch	mm		inch	mm		
10	3/8	18		-0618	3/4	19	7/8	22	<b>6680-0618</b>	1.06	27	2.40	61

**NOTE:** Hose Compatibility for the 6000 series can be found on page 353.

## 6000 SERIES FIELD ATTACHABLE INSERTS

<b>METRIC - DKL</b>	<b>6650</b>
---------------------	-------------

DKL  
METRIC (LIGHT)  
RYCO DKL FEMALE SWIVELS UP TO M26 SIZE  
HAVE MULTISEAL DKL 24° AND DKM 60°  
CONE.  
M30 AND OVER HAVE DKL  
24° CONE ONLY.

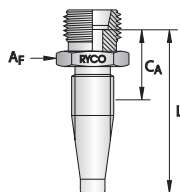

HOSE SIZE					THRD SIZE		TUBE SIZE		DASH SIZE		BACK UP AF		DKL MALE 24° CONE			
DN	inch	mm	mm		AF-SPANNER		PART NO	CA		L						
					inch	mm		inch	mm	inch	mm	inch	mm			
6	1/4	12	6	-0412		17	<b>6650-0412</b>	1.22	31	2.24	57					
6	1/4	14	8	-0414		17	<b>6650-0414</b>	1.22	31	2.24	57					
10	3/8	16	10	-0616	3/4	19	<b>6650-0616</b>	1.14	29	2.44	62					
10	3/8	18	12	-0618	3/4	19	<b>6650-0618</b>	1.14	29	2.44	62					
12	1/2	18	12	-0818	7/8	22	<b>6650-0818</b>	1.30	33	2.60	66					
12	1/2	22	15	-0822	15/16	24	<b>6650-0822</b>	1.34	34	2.64	67					
12	1/2	26	18	-0826	1.1/16	27	<b>6650-0826</b>	1.34	34	2.64	67					
16	5/8	26	18	-1026	1.1/16	27	<b>6650-1026</b>	1.42	36	2.83	72					
19	3/4	30	22	-1230	1.1/4	32	<b>6650-1230</b>	1.50	38	2.99	76					
25	1	36	28	-1636	1.5/8	41	<b>6650-1636</b>	1.69	43	3.19	81					

<b>METRIC - DKL</b>	<b>6600</b>
---------------------	-------------

DKL  
METRIC (LIGHT)  
RYCO DKL FEMALE SWIVELS UP TO M26 SIZE  
HAVE MULTISEAL DKL 24° AND DKM 60°  
CONE.  
M30 AND OVER HAVE DKL  
24° CONE ONLY.

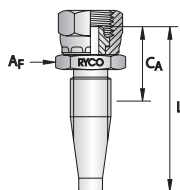

HOSE SIZE					THRD SIZE		TUBE SIZE		DASH SIZE		BACK UP AF		DKL FEMALE 24°/60° CONE			
DN	inch	mm	mm		AF-SPANNER		PART NO	CA		L						
					inch	mm		inch	mm	inch	mm	inch	mm			
6	1/4	12	6	-0412		17	<b>6600-0412</b>	1.34	34	2.36	60					
6	1/4	14	8	-0414		17	<b>6600-0414</b>	1.34	34	2.36	60					
6	1/4	16	10	-0416		17	<b>6600-0416</b>	1.38	35	2.44	62					
10	3/8	16	10	-0616	3/4	19	<b>6600-0616</b>	1.26	32	2.56	65					
10	3/8	18	12	-0618	7/8	22	<b>6600-0618</b>	1.34	34	2.64	67					
12	1/2	22	15	-0822			<b>6600-0822</b>	1.50	38	2.80	71					
12	1/2	26	18	-0826			<b>6600-0826</b>	1.54	39	2.83	72					
16	5/8	26	18	-1026			<b>6600-1026</b>	1.69	43	3.11	79					
19	3/4	30	22	-1230			<b>6600-1230</b>	1.69	43	3.15	80					
25	1	36	28	-1636	1.1/2	38	<b>6600-1636</b>	1.85	47	3.39	86					

**NOTE:** Hose Compatibility for the **6000** series can be found on page 353.

# COUPLINGS

## 6000 SERIES FIELD ATTACHABLE INSERTS

### METRIC - DKL

### 6660

DKL  
METRIC (LIGHT)  
RYCO DKL FEMALE SWIVELS UP TO M26 SIZE HAVE  
MULTISEAL DKL 24° AND DKM 60° CONE.  
M30 AND OVER HAVE DKL  
24° CONE ONLY.

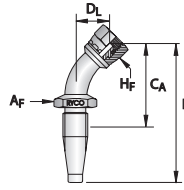

HOSE SIZE	THRD SIZE	TUBE SIZE	DASH SIZE	BACK UP AF	FEMALE HEX	DKL FEMALE 24°/60° CONE 45° TUBE BEND									
						AF-SPANNER		HF-SPANNER		PART NO	CA		L		DL
DN	inch	mm	mm		inch	mm	inch	mm	inch		mm	inch	mm	inch	mm
6	1/4	12	6	-0412		17		14	<b>6660-0412</b>	1.93	49	2.95	75	0.71	18
6	1/4	14	8	-0414		17		17	<b>6660-0414</b>	1.89	48	2.95	75	0.67	17
10	3/8	16	10	-0616	3/4	19	3/4	19	<b>6660-0616</b>	2.09	53	3.43	87	0.79	20
10	3/8	18	12	-0618	3/4	19	7/8	22	<b>6660-0618</b>	2.09	53	3.43	87	0.79	20
12	1/2	22	15	-0822	7/8	22	1.1/16	27	<b>6660-0822</b>	2.56	65	3.86	98	0.87	22
12	1/2	26	18	-0826			1.1/4	32	<b>6660-0826</b>	2.60	66	3.90	99	0.91	23
16	5/8	26	18	-1026	1.1/16	27	1.1/4	32	<b>6660-1026</b>	2.83	72	4.25	108	1.10	28
19	3/4	30	22	-1230		28		36	<b>6660-1230</b>	3.27	83	4.72	120	1.18	30
25	1	36	28	-1636	1.3/8	35	1.5/8	41	<b>6660-1636</b>	4.02	102	5.55	141	1.65	42

### METRIC - DKL

### 6670

DKL  
METRIC (LIGHT)  
RYCO DKL FEMALE SWIVELS UP TO M26 SIZE HAVE  
MULTISEAL DKL 24° AND DKM 60° CONE.  
M30 AND OVER HAVE DKL  
24° CONE ONLY.

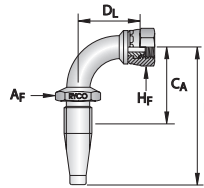

HOSE SIZE	THRD SIZE	TUBE SIZE	DASH SIZE	BACK UP AF	FEMALE HEX	DKL FEMALE 24°/60° CONE 90° TUBE BEND									
						AF-SPANNER		HF-SPANNER		PART NO	CA		L		DL
DN	inch	mm	mm		inch	mm	inch	mm	inch		mm	inch	mm	inch	mm
6	1/4	12	6	-0412		17		14	<b>6670-0412</b>	1.54	39	2.60	66	1.22	31
6	1/4	14	8	-0414		17		17	<b>6670-0414</b>	1.54	39	2.60	66	1.22	31
10	3/8	16	10	-0616	3/4	19	3/4	19	<b>6670-0616</b>	1.73	44	3.03	77	1.38	35
10	3/8	18	12	-0618	3/4	19	7/8	22	<b>6670-0618</b>	1.73	44	3.03	77	1.38	35
12	1/2	22	15	-0822	7/8	22	1.1/16	27	<b>6670-0822</b>	2.13	54	3.43	87	1.73	44
12	1/2	26	18	-0826			1.1/4	32	<b>6670-0826</b>	2.36	60	3.66	93	2.09	53
16	5/8	26	18	-1026	1.1/16	27	1.1/4	32	<b>6670-1026</b>	2.44	62	3.86	98	2.09	53
19	3/4	30	22	-1230				36	<b>6670-1230</b>	2.72	69	4.17	106	2.52	64
25	1	36	28	-1636			1.5/8	41	<b>6670-1636</b>	3.35	85	4.88	124	2.83	72

**NOTE:** Hose Compatibility for the 6000 series can be found on page 353.

## 6000 SERIES FIELD ATTACHABLE INSERTS

### METRIC - DKS 6630

**DKS**  
METRIC O RING (HEAVY)  
24° CONE

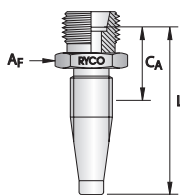

HOSE SIZE		THRD SIZE	TUBE SIZE	DASH SIZE	BACK UP AF		FEMALE HEX		DKS MALE 24° CONE				
DN	inch	mm	mm		Af-SPANNER		Hf-SPANNER		PART NO	CA		L	
					inch	mm	inch	mm		inch	mm	inch	mm
6	1/4	16	8	-0416		17		17	<b>6630-0416</b>	1.30	33	2.32	59
6	1/4	18	10	-0418	3/4	19	3/4	19	<b>6630-0418</b>	1.30	33	2.32	59
10	3/8	20	12	-0620	7/8	22	7/8	22	<b>6630-0620</b>	1.22	31	2.52	64
10	3/8	22	14	-0622	15/16	24	15/16	24	<b>6630-0622</b>	1.30	33	2.60	66
12	1/2	24	16	-0824	1.1/16	27	1.1/16	27	<b>6630-0824</b>	1.42	36	2.72	69
19	3/4	30	20	-1230	1.1/4	32	1.1/4	32	<b>6630-1230</b>	1.57	40	3.07	78
19	3/4	36	25	-1236	1.5/8	41	1.5/8	41	<b>6630-1236</b>	1.73	44	3.19	81
25	1	42	30			46		46	<b>6630-1642</b>	1.93	49	3.43	87

### METRIC - DKOS 6711

**DKOS**  
METRIC O RING (HEAVY)  
24° CONE

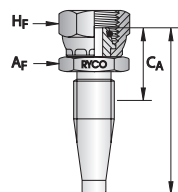

HOSE SIZE		THRD SIZE	TUBE SIZE	DASH SIZE	BACK UP AF		FEMALE HEX		DKOS FEMALE 24° CONE				
DN	inch	mm	mm		Af-SPANNER		Hf-SPANNER		PART NO	CA		L	
					inch	mm	inch	mm		inch	mm	inch	mm
6	1/4	16	8	-0416		17	3/4	19	<b>6711-0416</b>	1.34	34	2.40	61
6	1/4	18	10	-0418		17	7/8	22	<b>6711-0418</b>	1.34	34	2.40	61
10	3/8	20	12	-0620	3/4	19	15/16	24	<b>6711-0620</b>	1.26	32	2.60	66
10	3/8	22	14	-0622		20	1.1/16	27	<b>6711-0622</b>	1.42	36	2.76	70
12	1/2	24	16	-0824	7/8	22	1.3/16	30	<b>6711-0824</b>	1.61	41	2.87	73
19	3/4	30	20	-1230		28		36	<b>6711-1230</b>	1.73	44	3.19	81
19	3/4	36	25	-1236	1.3/8	35	1.5/8	41	<b>6711-1236</b>	1.89	48	3.35	85

**NOTE:** Hose Compatibility for the **6000** series can be found on page 353.

# COUPLINGS

## 6000 SERIES FIELD ATTACHABLE INSERTS

### METRIC - DKOS

### 6720

DKOS  
METRIC O RING (HEAVY)  
24° CONE

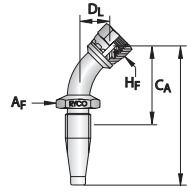

HOSE SIZE				THRD SIZE	TUBE SIZE	DASH SIZE	BACK UP AF		FEMALE HEX	DKOS FEMALE 24° CONE 45° TUBE BEND					
DN	inch	mm	mm		AF-SPANNER		HF-SPANNER		PART NO	CA		L		DL	
					inch	mm	inch	mm		inch	mm	inch	mm	inch	mm
6	1/4	16	8	-0416		17	3/4	19	<b>6720-0416</b>	1.89	48	2.95	75	0.71	18
6	1/4	18	10	-0418		17	7/8	22	<b>6720-0418</b>	1.85	47	2.91	74	0.67	17
10	3/8	20	12	-0620	3/4	19	15/16	24	<b>6720-0620</b>	2.17	55	3.46	88	0.79	20
10	3/8	22	14	-0622			1.1/16	27	<b>6720-0622</b>	2.20	56	3.50	89	0.75	19
12	1/2	24	16	-0824	7/8	22	1.3/16	30	<b>6720-0824</b>	2.64	67	3.94	100	0.94	24
19	3/4	30	20	-1230		28		36	<b>6720-1230</b>	3.43	87	4.88	124	1.38	35
19	3/4	36	25	-1236	1.3/8	35	1.5/8	41	<b>6720-1236</b>	3.62	92	5.08	129	1.38	35

### METRIC - DKOS

### 6730

DKOS  
METRIC O RING (HEAVY)  
24° CONE

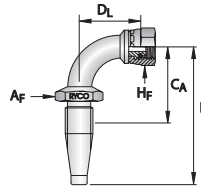

HOSE SIZE				THRD SIZE	TUBE SIZE	DASH SIZE	BACK UP AF		FEMALE HEX	DKOS FEMALE 24° CONE 90° TUBE BEND					
DN	inch	mm	mm		AF-SPANNER		HF-SPANNER		PART NO	CA		L		DL	
					inch	mm	inch	mm		inch	mm	inch	mm	inch	mm
6	1/4	16	8	-0416		17	3/4	19	<b>6730-0416</b>	1.54	39	2.60	66	1.22	31
6	1/4	18	10	-0418		17	7/8	22	<b>6730-0418</b>	1.54	39	2.60	66	1.18	30
10	3/8	20	12	-0620	3/4	19	15/16	24	<b>6730-0620</b>	1.77	45	3.07	78	1.42	36
10	3/8	22	14	-0622			1.1/16	27	<b>6730-0622</b>	1.77	45	3.07	78	1.46	37
12	1/2	24	16	-0824	7/8	22	1.3/16	30	<b>6730-0824</b>	2.13	54	3.43	87	1.89	48
19	3/4	30	20	-1230		28		36	<b>6730-1230</b>	2.68	68	4.13	105	2.64	67
19	3/4	36	25	-1236	1.3/8	35	1.5/8	41	<b>6730-1236</b>	2.68	68	4.13	105	2.64	67

**NOTE:** Hose Compatibility for the **6000** series can be found on page 353.

## 6000 SERIES FIELD ATTACHABLE INSERTS

<b>ORFS</b>	<b>6800</b>
-------------	-------------

**O RING  
FACE SEAL**

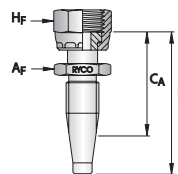

HOSE SIZE		THRD SIZE	TUBE SIZE	DASH SIZE	BACK UP AF		FEMALE HEX		ORFS FEMALE					
DN	inch	inch	inch		AF-SPANNER		HF-SPANNER		PART NO	CA		L		
					inch	mm	inch	mm		inch	mm	inch	mm	
5	3/16	9/16	1/4	-0309	5/8	16	11/16		<b>6800-0309</b>	1.26	32	2.05	52	
6	1/4	9/16	1/4	-0409	5/8	16	11/16		<b>6800-0409</b>	1.50	38	2.52	64	
6	1/4	11/16	3/8	-0411	11/16		7/8	22	<b>6800-0411</b>	1.57	40	2.60	66	
8	5/16	11/16	3/8	-0511	5/8	16	7/8	22	<b>6800-0511</b>	1.46	37	2.56	65	
10	3/8	11/16	3/8	-0611	11/16		7/8	22	<b>6800-0611</b>	1.42	36	2.76	70	
10	3/8	13/16	1/2	-0613	13/16		15/16	24	<b>6800-0613</b>	1.57	40	2.87	73	
12	1/2	13/16	1/2	-0813	13/16		15/16	24	<b>6800-0813</b>	1.61	41	2.91	74	
12	1/2	1	5/8	-0816	15/16	24	1.1/8		<b>6800-0816</b>	1.85	47	3.11	79	
16	5/8	1	5/8	-1016	1.1/8		1.1/8		<b>6800-1016</b>	1.93	49	3.35	85	
16	5/8	1.3/16	3/4	-1019	1.1/8		1.3/8		<b>6800-1019</b>	2.05	52	3.46	88	
19	3/4	1.3/16	3/4	-1219	1.1/8		1.3/8		<b>6800-1219</b>	1.97	50	3.46	88	
19	3/4	1.7/16	1	-1223	1.3/8		1.5/8	41	<b>6800-1223</b>	2.40	61	3.86	98	
22	7/8	1.7/16	1	-1423	1.3/8		1.5/8	41	<b>6800-1423</b>	2.32	59	3.39	86	
25	1	1.7/16	1	-1623	1.3/8		1.5/8	41	<b>6800-1623</b>	2.56	65	4.09	104	
31	1.1/4	1.11/16	1.1/4	-2027	1.43/50		2	50	<b>6800-2027</b>	2.83	72	4.96	126	

**NOTE:** Hose Compatibility for the **6000** series can be found on page 353.

INTRODUCTION

HOSE

COUPLINGS

ADAPTORS

TECHNICAL



# COUPLINGS

## 6000 SERIES FIELD ATTACHABLE INSERTS

<b>ORFS</b>	<b>6810</b>
-------------	-------------

O RING  
FACE SEAL

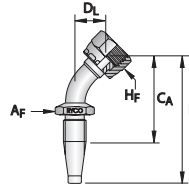

HOSE SIZE		THRD SIZE	TUBE SIZE	DASH SIZE	BACK UP Af		FEMALE HEX		ORFS FEMALE 45° TUBE BEND						
DN	inch	inch	inch		Af-SPANNER		Hf-SPANNER		PART NO	CA		L		DL	
					inch	mm	inch	mm		inch	mm	inch	mm	inch	mm
5	3/16	9/16	1/4	-0309	5/8	16	11/16		<b>6810-0309</b>	1.81	46	2.60	66	0.71	18
6	1/4	9/16	1/4	-0409	5/8	16	11/16		<b>6810-0409</b>	2.01	51	3.07	78	0.71	18
6	1/4	11/16	3/8	-0411	5/8	16	7/8	22	<b>6810-0411</b>	2.01	51	3.07	78	0.75	19
8	5/16	11/16	3/8	-0511	5/8	16	7/8	22	<b>6810-0511</b>	2.13	54	3.23	82	0.79	20
10	3/8	11/16	3/8	-0611	11/16		7/8	22	<b>6810-0611</b>	2.09	53	3.43	87	0.79	20
10	3/8	13/16	1/2	-0613	3/4	19	15/16	24	<b>6810-0613</b>	1.93	49	3.23	82	0.67	17
12	1/2	13/16	1/2	-0813	13/16		15/16	24	<b>6810-0813</b>	2.36	60	3.66	93	0.75	19
12	1/2	1	5/8	-0816	15/16	24	1.1/8		<b>6810-0816</b>	2.36	60	3.66	93	0.75	19
16	5/8	1	5/8	-1016	1		1.1/8		<b>6810-1016</b>	2.87	73	4.29	109	0.79	20
16	5/8	1.3/16	3/4	-1019	1.1/8		1.3/8		<b>6810-1019</b>	2.87	73	4.29	109	0.94	24
19	3/4	1.3/16	3/4	-1219	1.1/8		1.3/8		<b>6810-1219</b>	2.99	76	4.49	114	1.14	29
19	3/4	1.7/16	1	-1223	1.3/8		1.5/8	41	<b>6810-1223</b>	3.03	77	4.53	115	1.02	26
22	7/8	1.7/16	1	-1423	1.3/8		1.5/8	41	<b>6810-1423</b>	3.74	95	4.80	122	1.34	34
25	1	1.7/16	1	-1623	1.3/8		1.5/8	41	<b>6810-1623</b>	3.98	101	5.51	140	1.34	34

<b>ORFS</b>	<b>6820</b>
-------------	-------------

O RING  
FACE SEAL

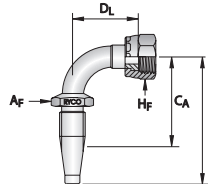

HOSE SIZE		THRD SIZE	TUBE SIZE	DASH SIZE	BACK UP Af		FEMALE HEX		ORFS FEMALE 45° TUBE BEND						
DN	inch	inch	inch		Af-SPANNER		Hf-SPANNER		PART NO	CA		L		DL	
					inch	mm	inch	mm		inch	mm	inch	mm	inch	mm
5	3/16	9/16	1/4	-0309	5/8	16	11/16		<b>6820-0309</b>	1.38	35	2.17	55	1.26	32
6	1/4	9/16	1/4	-0409	5/8	16	11/16		<b>6820-0409</b>	1.57	40	2.64	67	1.26	32
6	1/4	11/16	3/8	-0411	5/8	16	7/8	22	<b>6820-0411</b>	1.57	40	2.64	67	1.50	38
8	5/16	11/16	3/8	-0511	5/8	16	7/8	22	<b>6820-0511</b>	1.73	44	2.80	71	1.46	37
10	3/8	11/16	3/8	-0611	11/16		7/8	22	<b>6820-0611</b>	1.69	43	2.99	76	1.50	38
10	3/8	13/16	1/2	-0613	3/4	19	15/16	24	<b>6820-0613</b>	1.69	43	2.99	76	1.61	41
12	1/2	13/16	1/2	-0813	13/16		15/16	24	<b>6820-0813</b>	2.05	52	3.35	85	1.61	41
12	1/2	1	5/8	-0816	15/16	24	1.1/8		<b>6820-0816</b>	2.17	55	3.46	88	1.85	47
16	5/8	1	5/8	-1016	1		1.1/8		<b>6820-1016</b>	2.40	61	3.82	97	1.85	47
16	5/8	1.3/16	3/4	-1019	1.1/8		1.3/8		<b>6820-1019</b>	2.52	64	3.94	100	2.28	58
19	3/4	1.3/16	3/4	-1219	1.1/8		1.3/8		<b>6820-1219</b>	2.60	66	4.06	103	2.32	59
19	3/4	1.7/16	1	-1223	1.3/8		1.5/8	41	<b>6820-1223</b>	2.80	71	4.25	108	2.80	71
22	7/8	1.7/16	1	-1423	1.3/8		1.5/8	41	<b>6820-1423</b>	3.11	79	4.17	106	2.80	71
25	1	1.7/16	1	-1623	1.3/8		1.5/8	41	<b>6820-1623</b>	3.35	85	4.88	124	2.80	71
31	1.1/4	1.11/16	1.1/4	-2027	1.3/4		2	50	<b>6820-2027</b>	4.17	106	6.30	160	3.54	90

## 6000 SERIES FIELD ATTACHABLE INSERTS

<b>ORFS</b>	<b>6830</b>
-------------	-------------

**O RING  
FACE SEAL**

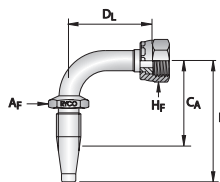

HOSE SIZE		THRD SIZE	TUBE SIZE	DASH SIZE	BACK UP AF		FEMALE HEX		ORFS FEMALE 90° LONG BEND						
DN	inch	inch	inch		Af-SPANNER		Hf-SPANNER		PART NO	CA		L		DL	
	inch	inch	inch		inch	mm	inch	mm		inch	mm	inch	mm	inch	mm
5	3/16	9/16	1/4	-0309	5/8	16	11/16		<b>6830-0309</b>	1.38	35	2.20	56	1.85	47
6	1/4	9/16	1/4	-0409	5/8	16	11/16		<b>6830-0409</b>	1.61	41	2.64	67	1.85	47
6	1/4	11/16	3/8	-0411	5/8	16	7/8	22	<b>6830-0411</b>	1.57	40	2.64	67	2.13	54
8	5/16	11/16	3/8	-0511	5/8	16	7/8	22	<b>6830-0511</b>	1.61	41	2.72	69	2.13	54
10	3/8	11/16	3/8	-0611	11/16		7/8	22	<b>6830-0611</b>	1.61	41	2.91	74	2.13	54
10	3/8	13/16	1/2	-0613	3/4	19	15/16	24	<b>6830-0613</b>	1.61	41	2.91	74	2.52	64
12	1/2	13/16	1/2	-0813	13/16		15/16	24	<b>6830-0813</b>	2.09	53	3.39	86	2.56	65
12	1/2	1	5/8	-0816	15/16	24	1.1/8		<b>6830-0816</b>	2.28	58	3.58	91	2.76	70
16	5/8	1	5/8	-1016	1		1.1/8		<b>6830-1016</b>	2.56	65	3.98	101	2.76	70
16	5/8	1.3/16	3/4	-1019	1.1/8		1.3/8		<b>6830-1019</b>	2.48	63	3.90	99	3.78	96
19	3/4	1.3/16	3/4	-1219	1.1/8		1.3/8		<b>6830-1219</b>	2.80	71	4.25	108	3.78	96
19	3/4	1.7/16	1	-1223	1.3/8		1.5/8	41	<b>6830-1223</b>	2.76	70	4.21	107	4.49	114
22	7/8	1.7/16	1	-1423	1.3/8		1.5/8	41	<b>6830-1423</b>	3.43	87	4.49	114	4.45	113
25	1	1.7/16	1	-1623	1.3/8		1.5/8	41	<b>6830-1623</b>	3.66	93	5.20	132	4.45	113
31	1.1/4	1.11/16	1.1/4	-2027	1.3/4		2	50	<b>6830-2027</b>	4.17	106	6.30	160	5.08	129

<b>SAE</b>	<b>6530</b>
------------	-------------

**45° FLARE**

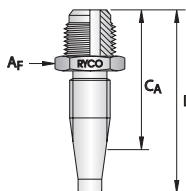

HOSE SIZE		THRD SIZE	TUBE SIZE	DASH SIZE	BACK UP AF		SAE MALE					
DN	inch	inch	inch		Af-SPANNER		PART NO	CA		L		
	inch	inch	inch		inch	mm		inch	mm	inch	mm	
6	1/4	5/8	3/8	-0410	11/16		<b>6530-0410</b>	1.46	37	2.48	63	
8	5/16	5/8	3/8	-0510	5/8	16	<b>6530-0510</b>	1.34	34	2.40	61	
10	3/8	1/2	5/16	-0608	5/8	16	<b>6530-0608</b>	1.26	32	2.56	65	
10	3/8	5/8	3/8	-0610	3/4	19	<b>6530-0610</b>	1.30	33	2.60	66	

**NOTE:** Hose Compatibility for the **6000** series can be found on page 353.

INTRODUCTION

HOSE

COUPLINGS

ADAPTORS

TECHNICAL

# COUPLINGS

## 6000 SERIES FIELD ATTACHABLE INSERTS

SAE	6540
-----	------

45° FLARE

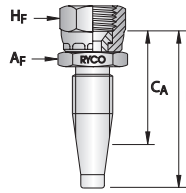

HOSE SIZE		THRD SIZE	TUBE SIZE	DASH SIZE	BACK UP AF		FEMALE HEX		SAE FEMALE					
DN	inch	inch	inch		AF-SPANNER		HF-SPANNER		PART NO	CA		L		
					inch	mm	inch	mm		inch	mm	inch	mm	
5	3/16	7/16	1/4	-0307	5/8	16	9/16		<b>6540-0307</b>	0.91	23	1.73	44	
6	1/4	7/16	1/4	-0407	11/16		9/16		<b>6540-0407</b>	1.14	29	2.17	55	
6	1/4	1/2	5/16	-0408	11/16		5/8	16	<b>6540-0408</b>	1.14	29	2.17	55	
6	1/4	5/8	3/8	-0410	11/16		3/4	19	<b>6540-0410</b>	1.14	29	2.20	56	
8	5/16	5/8	3/8	-0510	11/16		3/4	19	<b>6540-0510</b>	1.06	27	2.13	54	
10	3/8	1/2	5/16	-0608	11/16		5/8	16	<b>6540-0608</b>	1.02	26	2.32	59	
10	3/8	5/8	3/8	-0610	3/4	19	3/4	19	<b>6540-0610</b>	1.02	26	2.36	60	
10	3/8	3/4	1/2	-0612	7/8	22	7/8	22	<b>6540-0612</b>	1.14	29	2.44	62	
12	1/2	3/4	1/2	-0812	7/8	22	7/8	22	<b>6540-0812</b>	1.26	32	2.56	65	
12	1/2	7/8	5/8	-0814	1		1.1/16	27	<b>6540-0814</b>	1.30	33	2.60	66	
16	5/8	1.1/16	3/4	-1017	1.1/8		1.1/4	32	<b>6540-1017</b>	1.50	38	2.91	74	
19	3/4	1.1/16	3/4	-1217	1.1/8		1.1/4	32	<b>6540-1217</b>	1.46	37	2.91	74	

SAE	6580	6570
-----	------	------

45° FLARE

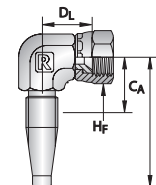
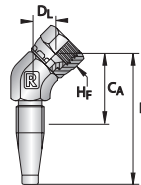

HOSE SIZE		THRD SIZE	TUBE SIZE	DASH SIZE	FEMALE HEX		SAE FEMALE 45° ELBOW						SAE FEMALE 90° ELBOW							
DN	inch	inch	inch		HF-SPANNER		PART NO	CA		L		DL		PART NO	CA		L		DL	
					inch	mm		inch	mm	inch	mm	inch	mm		inch	mm	inch	mm	inch	mm
10	3/8	1/2	5/16	-0608	5/8	16	<b>6580-0608</b>	1.54	39	2.83	72	0.55	14	<b>6570-0608</b>	0.98	25	2.28	58	0.91	23
10	3/8	5/8	3/8	-0610	3/4	19	<b>6580-0610</b>	1.54	39	2.87	73	0.59	15	<b>6570-0610</b>	0.98	25	2.28	58	0.91	23

**NOTE:** Hose Compatibility for the 6000 series can be found on page 353.

## 6000 SERIES FIELD ATTACHABLE INSERTS

<b>SAE</b>	<b>6550</b>
------------	-------------

45° FLARE

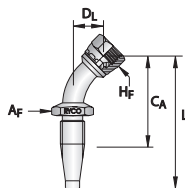

HOSE SIZE	THRD SIZE	TUBE SIZE	DASH SIZE	BACK UP AF	FEMALE HEX	SAE FEMALE 45° TUBE BEND									
						AF-SPANNER		HF-SPANNER		PART NO	CA		L		DL
DN	inch	inch	inch		inch	mm	inch	mm	inch		mm	inch	mm	inch	mm
5	3/16	7/16	1/4	-0307	5/8	16	9/16		<b>6550-0307</b>	1.57	40	2.36	60	0.59	15
8	5/16	5/8	3/8	-0510	5/8	16	3/4	19	<b>6550-0510</b>	2.01	51	3.07	78	0.67	17
10	3/8	1/2	5/16	-0608	11/16		5/8	16	<b>6550-0608</b>	1.89	48	3.23	82	0.59	15
10	3/8	5/8	3/8	-0610	11/16		3/4	19	<b>6550-0610</b>	1.97	50	3.27	83	0.67	17

<b>SAE</b>	<b>6560</b>
------------	-------------

45° FLARE

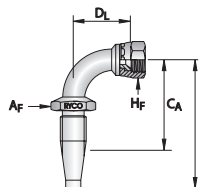

HOSE SIZE	THRD SIZE	TUBE SIZE	DASH SIZE	BACK UP AF	FEMALE HEX	SAE FEMALE 90° TUBE BEND									
						AF-SPANNER		HF-SPANNER		PART NO	CA		L		DL
DN	inch	inch	inch		inch	mm	inch	mm	inch		mm	inch	mm	inch	mm
5	3/16	7/16	1/4	-0307	5/8	16	9/16		<b>6560-0307</b>	1.30	33	2.13	54	1.14	29
8	5/16	5/8	3/8	-0510	5/8	16	3/4	19	<b>6560-0510</b>	1.73	44	2.80	71	1.30	33
10	3/8	5/8	3/8	-0610	11/16		3/4	19	<b>6560-0610</b>	1.69	43	2.99	76	1.30	33

<b>SAE</b>	<b>6563</b>
------------	-------------

45° FLARE

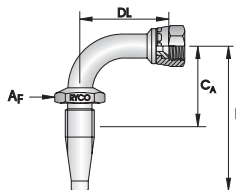

HOSE SIZE	THRD SIZE	TUBE SIZE	DASH SIZE	BACK UP AF	FEMALE HEX	SAE FEMALE 90° LONG TUBE BEND									
						AF-SPANNER		HF-SPANNER		PART NO	CA		L		DL
DN	inch	inch	inch		inch	mm	inch	mm	inch		mm	inch	mm	inch	mm
10	3/8	5/8	3/8	-0610	11/16		3/4	19	<b>6563-0610</b>	1.61	41	2.91	74	2.17	55

**NOTE:** Hose Compatibility for the 6000 series can be found on page 353.

INTRODUCTION

HOSE

COUPLINGS

ADAPTORS

TECHNICAL

# COUPLINGS

## 6000 SERIES FIELD ATTACHABLE INSERTS

<b>SAE</b>	<b>6740</b>	<b>6780</b>
------------	-------------	-------------

**INVERTED  
MALE FLARE**

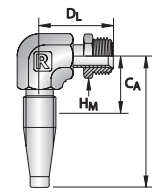
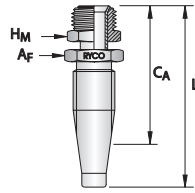

HOSE SIZE		THRD SIZE	TUBE SIZE	DASH SIZE	BACK UP AF		MALE HEX		SAE INVERTED MALE FLARE				SAE INVERTED MALE FLARE 90° ELBOW										
DN	inch	inch	inch		AF-SPANNER		HM-SPANNER		PART NO		CA		L		PART NO		CA		L		DL		
					inch	mm	inch	mm			inch	mm	inch	mm			inch	mm	inch	mm	inch	mm	
6	1/4	7/16	1/4	-0407	5/8	16	7/16	11	<b>6740-0407</b>	1.97	50	3.03	77										
8	5/16	5/8	3/8	-0510	5/8	16	5/8	16	<b>6740-0510</b>	1.89	48	2.95	75										
10	3/8	5/8	3/8	-0610	11/16		5/8	16	<b>6740-0610</b>	1.85	47	3.15	80	<b>6780-0610</b>	0.98	25	2.28	58	1.26	32			
10	3/8	11/16	7/16	-0611	11/16		11/16		<b>6740-0611</b>	1.97	50	3.31	84	<b>6780-0611</b>	1.02	26	2.32	59	1.42	36			

<b>SAE</b>	<b>6790</b>
------------	-------------

**INVERTED  
MALE FLARE**

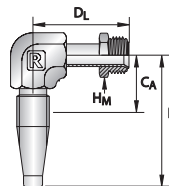

HOSE SIZE		THRD SIZE	TUBE SIZE	DASH SIZE	MALE HEX		SAE INVERTED MALE FLARE 90° EXTENDED ELBOW							
DN	inch	inch	inch		HM-SPANNER		PART NO		CA		L		DL	
					inch	mm			inch	mm	inch	mm	inch	mm
10	3/8	5/8	3/8	-0610	3/4	19	<b>6790-0610</b>		0.98	25	2.28	58	2.36	60

<b>SAE</b>	<b>6750</b>
------------	-------------

**INVERTED  
MALE FLARE**

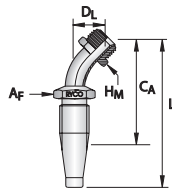

HOSE SIZE		THRD SIZE	TUBE SIZE	DASH SIZE	BACK UP AF		MALE HEX		SAE INVERTED MALE FLARE 45° TUBE BEND								
DN	inch	inch	inch		AF-SPANNER		HM-SPANNER		PART NO		CA		L		DL		
					inch	mm	inch	mm			inch	mm	inch	mm	inch	mm	
8	5/16	5/8	3/8	-0510	5/8	16	5/8	16	<b>6750-0510</b>	3.15	80	4.21	107	0.91	23		
10	3/8	5/8	3/8	-0610	11/16		11/16		<b>6750-0610</b>	3.11	79	4.45	113	0.91	23		

**NOTE:** Hose Compatibility for the **6000** series can be found on page 353.

## 6000 SERIES FIELD ATTACHABLE INSERTS

<b>SAE</b>	<b>6760</b>
------------	-------------

**INVERTED  
MALE FLARE**

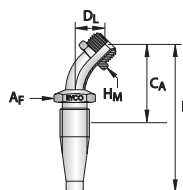

HOSE SIZE	THRD SIZE	TUBE SIZE	DASH SIZE	BACK UP AF	MALE HEX	SAE INVERTED MALE FLARE 60° TUBE BEND									
						AF-SPANNER		HM-SPANNER		PART NO	CA		L		DL
DN	inch	inch	inch		inch	mm	inch	mm			inch	mm	inch	mm	inch
6	1/4	7/16	1/4	-0407	5/8	16	7/16	11	<b>6760-0407</b>	2.83	72	3.90	99	1.14	29

<b>SAE</b>	<b>6770</b>
------------	-------------

**INVERTED  
MALE FLARE**

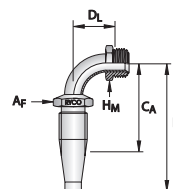

HOSE SIZE	THRD SIZE	TUBE SIZE	DASH SIZE	BACK UP AF	MALE HEX	SAE INVERTED MALE FLARE 90° TUBE BEND									
						AF-SPANNER		HM-SPANNER		PART NO	CA		L		DL
DN	inch	inch	inch		inch	mm	inch	mm			inch	mm	inch	mm	inch
6	1/4	7/16	1/4	-0407	5/8	16	7/16	11	<b>6770-0407</b>	2.05	52	3.07	78	1.50	38
8	5/16	5/8	3/8	-0510	5/8	16	5/8	16	<b>6770-0510</b>	2.44	62	3.50	89	1.97	50
10	3/8	5/8	3/8	-0610	11/16		5/8	16	<b>6770-0610</b>	2.40	61	3.70	94	1.97	50

**NOTE:** Hose Compatibility for the **6000** series can be found on page 353.

INTRODUCTION

HOSE

COUPLINGS

ADAPTORS

TECHNICAL

# COUPLINGS

## 6000 SERIES FIELD ATTACHABLE INSERTS

### DIMENSIONS FOR SAE CODE 61 AND CODE 62 FLANGES, AND RYCO CODE 62C FLANGES

NOMINAL FLANGE	CODE 61				CODE 62				CODE 62C			
	B		T		B		T		B		T	
inch	mm	inch	mm	inch	mm	inch	mm	inch	mm	inch	mm	inch
1/2	30,2	1.19	6,73	0.265	31,8	1.25	7,75	0.305				
*5/8	34,0	1.34	6,73	0.265								
3/4	38,1	1.50	6,73	0.265	41,3	1.63	8,76	0.345	41,3	1.63	14,20	0.559
1	44,5	1.75	8,00	0.315	47,6	1.88	9,53	0.375	47,6	1.88	14,20	0.559
1.1/4	50,8	2.00	8,00	0.315	54,0	2.12	10,29	0.405	54,0	2.12	14,20	0.559
1.1/2	60,3	2.38	8,00	0.315	63,5	2.50	12,57	0.495	63,5	2.50	14,20	0.559
2	71,4	2.81	9,53	0.375	79,4	3.13	12,57	0.495	79,4	3.13	14,20	0.559
2.1/2	84,1	3.31	9,53	0.375								
3	101,6	4.00	9,53	0.375								

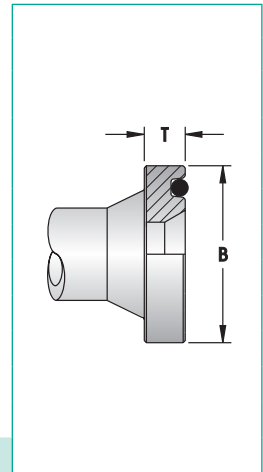

**NOTE:** RYCO Code 62C fittings conform to the flange OD and bolt hole patterns of SAE Code 62 but require special flange clamps. RYCO Code 62C flange heads are thicker than SAE Code 62 and measure T = 14,2 mm (0.559 inch) in all sizes.

### SAE FLANGE

### 6150

CLAMPS - SEE PAGES  
440 & 441  
O RING NOT SUPPLIED

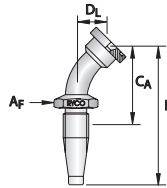

HOSE SIZE	NOM. FLANGE SIZE	DASH SIZE	BACK UP Af	CODE 61 FLANGE 45° TUBE BEND								
				Af-SPANNER		PART NO	CA		L		DL	
DN	inch	inch		inch	mm			inch	mm	inch	mm	inch
12	1/2	1/2	-0808	13/16		<b>6150-0808</b>	2.44	62			0.79	20
12	1/2	3/4	-0812	13/16		<b>6150-0812</b>	2.52	64			0.94	24
16	5/8	5/8	-1010	1		<b>6150-1010</b>	2.76	70			0.94	24
19	3/4	3/4	-1212	1.1/8		<b>6150-1212</b>	3.07	78			1.02	26
19	3/4	1	-1216	1.1/8		<b>6150-1216</b>	3.23	82			1.18	30
19	3/4	1.1/4	-1220	1.1/8		<b>6150-1220</b>	3.31	84			1.26	32
25	1	1	-1616	1.3/8		<b>6150-1616</b>	3.82	97			1.18	30
25	1	1.1/4	-1620	1.3/8		<b>6150-1620</b>	3.90	99			1.26	32
25	1	1.1/2	-1624	1.3/8		<b>6150-1624</b>	3.98	101			1.30	33
31	1.1/4	1	-2016	1.43/50		<b>6150-2016</b>	4.02	102			1.18	30
31	1.1/4	1.1/4	-2020	2		<b>6150-2020</b>	18	119			1.42	36
31	1.1/4	1.1/2	-2024	1.43/50		<b>6150-2024</b>	4.80	122			1.50	38
51	2	2	-3232	2.3/4	70	<b>6150-3232</b>	6.57	167			2.28	58

**NOTE:** Hose Compatibility for the **6000** series can be found on page 353.



## 6000 SERIES FIELD ATTACHABLE INSERTS

<b>SAE FLANGE</b>	<b>6170</b>
-------------------	-------------

CLAMPS - SEE PAGES  
440 & 441  
O RING NOT SUPPLIED

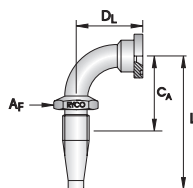

HOSE SIZE		NOM. FLANGE SIZE	DASH SIZE	BACK UP AF		CODE 61 FLANGE 90° TUBE BEND						
DN	inch	inch		AF-SPANNER		PART NO	CA		L		DL	
				inch	mm		inch	mm	inch	mm	inch	mm
12	1/2	1/2	-0808	13/16		<b>6170-0808</b>	2.13	54	3.43	87	1.61	41
12	1/2	3/4	-0812	13/16		<b>6170-0812</b>	2.13	54	3.43	87	1.73	44
16	5/8	5/8	-1010	1		<b>6170-1010</b>	2.44	62	3.86	98	1.89	48
19	3/4	3/4	-1212	1.1/8		<b>6170-1212</b>	2.68	68	4.13	105	2.13	54
19	3/4	1	-1216	1.1/8		<b>6170-1216</b>	2.68	68	4.13	105	2.36	60
19	3/4	1.1/4	-1220	1.1/8		<b>6170-1220</b>	2.68	68	4.13	105	2.44	62
25	1	1	-1616	1.3/8		<b>6170-1616</b>	3.31	84	4.84	123	2.68	68
25	1	1.1/4	-1620	1.3/8		<b>6170-1620</b>	3.31	84	4.84	123	2.72	69
25	1	1.1/2	-1624	1.3/8		<b>6170-1624</b>	3.31	84	4.84	123	2.87	73
31	1.1/4	1	-2016	1.43/50		<b>6170-2016</b>	3.58	91	5.71	145	2.68	68
31	1.1/4	1.1/4	-2020	1.43/50		<b>6170-2020</b>	4.21	107	6.34	161	3.03	77
31	1.1/4	1.1/2	-2024	1.43/50		<b>6170-2024</b>	4.21	107	6.34	161	3.19	81
38	1.1/2	1.1/2	-2424	2.1/4	57	<b>6170-2424</b>	4.76	121	7.24	184	3.66	93
38	1.1/2	2	-2432	2.1/4	57	<b>6170-2432</b>	4.76	121	7.24	184	3.90	99
51	2	2	-3232	2.3/4	70	<b>6170-3232</b>	6.18	157	8.94	227	4.96	126

**NOTE:** Hose Compatibility for the **6000** series can be found on page 353.

INTRODUCTION

HOSE

COUPLINGS

ADAPTORS

TECHNICAL

# COUPLINGS

## 6000 SERIES FIELD ATTACHABLE INSERTS

<b>SALVAGE</b>	<b>6230</b>
----------------	-------------

TUBE WELD

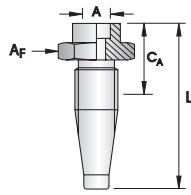

HOSE SIZE		A	DASH SIZE	BACK UP Af		SALVAGE (LIVESAVER)				
DN	inch	inch		Af-SPANNER		PART NO	CA		L	
				inch	mm		inch	mm	inch	mm
6	1/4	1/4	-0404	5/8	16	<b>6230-0404</b>	1.10	28	2.13	54
6	1/4	3/8	-0406	5/8	16	<b>6230-0406</b>	1.10	28	2.13	54
8	5/16	3/8	-0506	5/8	16	<b>6230-0506</b>	0.98	25	2.09	53
10	3/8	3/8	-0606	11/16		<b>6230-0606</b>	0.94	24	2.28	58
10	3/8	1/2	-0608	11/16		<b>6230-0608</b>	0.94	24	2.28	58
12	1/2	1/2	-0808	13/16		<b>6230-0808</b>	1.14	29	2.44	62
12	1/2	5/8	-0810	7/8	22	<b>6230-0810</b>	1.14	29	2.44	62
12	1/2	3/4	-0812	1.1/16	27	<b>6230-0812</b>	1.14	29	2.44	62
16	5/8	5/8	-1010	1		<b>6230-1010</b>	1.22	31	2.64	67
16	5/8	3/4	-1012	1		<b>6230-1012</b>	1.22	31	2.64	67
19	3/4	3/4	-1212	1.1/16	27	<b>6230-1212</b>	1.18	30	2.64	67
19	3/4	1	-1216	1.3/8		<b>6230-1216</b>	1.34	34	2.83	72
22	7/8	1	-1416	1.3/8		<b>6230-1416</b>	1.26	32	2.36	60
25	1	3/4	-1612	1.3/8		<b>6230-1612</b>	1.46	37	2.99	76
25	1	1	-1616	1.3/8		<b>6230-1616</b>	1.54	39	3.07	78
25	1	1.1/4	-1620	1.3/4		<b>6230-1620</b>	1.57	40	3.11	79
28	1.1/8	1.1/4	-1820	1.43/50		<b>6230-1820</b>	1.61	41	2.91	74
31	1.1/4	1.1/4	-2020	1.3/4		<b>6230-2020</b>	1.73	44	3.86	98
35	1.3/8	1.1/2	-2224	2		<b>6230-2224</b>	1.34	34	2.64	67
38	1.1/2	1.1/2	-2424	2.1/4	57	<b>6230-2424</b>	1.57	40	4.06	103
51	2	2	-3232	2.1/2		<b>6230-3232</b>	1.97	50	4.76	121

**NOTE:** Hose Compatibility for the **6000** series can be found on page 353.

## 6000 SERIES FIELD ATTACHABLE INSERTS

### STANDPIPE 6180

IMPERIAL

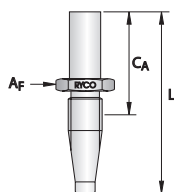

HOSE SIZE		TUBE SIZE	DASH SIZE	BACK UP AF		IMPERIAL STANDPIPE					
DN	inch	inch		AF-SPANNER		PART NO	CA		L		
				inch	mm		inch	mm	inch	mm	
6	1/4	5/16	-0405	5/8	16	<b>6180-0405</b>	1.69	43	2.72	69	
6	1/4	3/8	-0406	5/8	16	<b>6180-0406</b>	1.73	44	2.76	70	
10	3/8	3/8	-0606	5/8	16	<b>6180-0606</b>	1.61	41	2.91	74	
10	3/8	1/2	-0608	5/8	16	<b>6180-0608</b>	1.61	41	2.91	74	
12	1/2	1/2	-0808	13/16		<b>6180-0808</b>	1.77	45	3.07	78	
12	1/2	5/8	-0810	13/16		<b>6180-0810</b>	2.05	52	3.35	85	
19	3/4	7/8	-1212	1.1/16	27	<b>6180-1212</b>	2.32	59	3.78	96	
31	1.1/4	1.1/4	-1214	1.1/16		<b>6180-1214</b>	2.60	66	4.06	103	
31	1.1/4	1.1/4	-2020	1.3/4		<b>6180-2020</b>	3.19	81	5.31	135	

### STANDPIPE 6640

METRIC

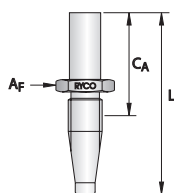

HOSE SIZE		TUBE SIZE	DASH SIZE	BACK UP AF		METRIC STANDPIPE					
DN	inch	inch		AF-SPANNER		PART NO	CA		L		
				inch	mm		inch	mm	inch	mm	
6	1/4	6	-0406	5/8	16	<b>6640-0406</b>	1.69	43	2.72	69	
6	1/4	8	-0408	5/8	16	<b>6640-0408</b>	1.69	43	2.72	69	
6	1/4	10	-0410	5/8	16	<b>6640-0410</b>	1.73	44	2.76	70	
10	3/8	10	-0610	11/16		<b>6640-0610</b>	1.61	41	2.91	74	
10	3/8	12	-0612	3/4	19	<b>6640-0612</b>	1.61	41	2.91	74	
10	3/8	14	-0614	11/16		<b>6640-0614</b>	1.81	46	3.15	80	
12	1/2	15	-0815	7/8	22	<b>6640-0815</b>	1.85	47	3.15	80	
12	1/2	16	-0816	7/8	22	<b>6640-0816</b>	2.05	52	3.35	85	
16	5/8	16	-1016	1		<b>6640-1016</b>	2.13	54	3.54	90	
19	3/4	20	-1220	1.1/8		<b>6640-1220</b>	2.36	60	3.86	98	
19	3/4	22	-1222	1.1/8		<b>6640-1222</b>	2.05	52	3.54	90	
25	1	30	-1630	1.3/8		<b>6640-1630</b>	2.91	74	4.45	113	

**NOTE:** See RYCO Adaptors Catalogue DKL and DKS Metric Nuts and Olives for use with Metric Standpipe Fittings.

**NOTE:** Hose Compatibility for the 6000 series can be found on page 353.

INTRODUCTION

HOSE

COUPLINGS

ADAPTORS

TECHNICAL

# COUPLINGS

## 6000 SERIES FIELD ATTACHABLE INSERTS

### TUBE BITE

**6850**

COMPLETE WITH NUT  
AND FLARELESS OLIVE

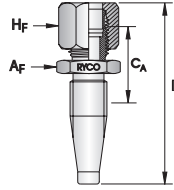

HOSE SIZE		TUBE SIZE	DASH SIZE	BACK UP AF		FEMALE HEX		TUBE BITE				
DN	inch	inch		AF-SPANNER	HF-SPANNER	PART NO		CA		L		
				inch	mm	inch	mm	inch	mm	inch	mm	
10	3/8	3/8	-0606	3/4	19	11/16		<b>6850-0606</b>	1.14	29	2.48	63

### UNO (O RING BOSS)

**6380**

O RING SUPPLIED

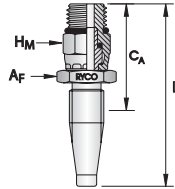

HOSE SIZE		THRD SIZE	TUBE SIZE	DASH SIZE	BACK UP AF		MALE HEX		UN O RING MALE SWIVEL					
DN	inch	inch	inch		AF-SPANNER		HM-SPANNER		PART NO		CA		L	
					inch	mm	inch	mm	inch	mm	inch	mm	inch	mm
6	1/4	9/16	3/8	-0409	11/16		11/16		<b>6380-0409</b>	1.77	45	2.80	71	
10	3/8	3/4	1/2	-0612	7/8	22	7/8	22	<b>6380-0612</b>	1.89	48	3.23	82	
12	1/2	7/8	5/8	-0814	7/8	22	1		<b>6380-0814</b>	2.05	52	3.35	85	
16	5/8	7/8	5/8	-1014	1		1		<b>6380-1014</b>	2.13	54	3.54	90	

**NOTE:** The "Live Swivel" 6380 Series Insert is for Maximum Working Pressure: 350 bar (5100 psi): -09 & -12 Thread Size, 280 bar (4100 psi): -14 & -17 Thread Size. Their swivel capability is to allow easy installation and orientation and avoid twisting of hose. They are not designed for continuous rotation or continuous movement.

**NOTE:** Hose Compatibility for the 6000 series can be found on page 353.

## 6000 SERIES FIELD ATTACHABLE INSERTS

### UNO (O RING BOSS) 6200

O RING SUPPLIED

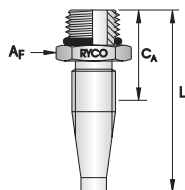

HOSE SIZE		THRD SIZE	TUBE SIZE	DASH SIZE	BACK UP Af		MALE HEX		UN O RING MALE				
DN	inch	inch	inch		Af-SPANNER		HM-SPANNER		PART NO	CA		L	
					inch	mm	inch	mm		inch	mm	inch	mm
6	1/4	9/16	3/8	-0409	11/16		11/16		<b>6200-0409</b>	1.22	31	2.24	57
10	3/8	9/16	3/8	-0609	3/4	19	3/4	19	<b>6200-0609</b>	1.06	27	2.40	61
10	3/8	3/4	1/2	-0612	7/8	22	7/8	22	<b>6200-0612</b>	1.18	30	2.52	64
10	3/8	7/8	5/8	-0614	1		1		<b>6200-0614</b>	1.26	32	2.56	65
12	1/2	3/4	1/2	-0812	7/8	22	7/8	22	<b>6200-0812</b>	1.30	33	2.60	66
12	1/2	7/8	5/8	-0814	1		1		<b>6200-0814</b>	1.38	35	2.68	68
12	1/2	1.1/16	3/4	-0817	1.1/4	32	1.1/4	32	<b>6200-0817</b>	1.54	39	2.83	72
16	5/8	7/8	5/8	-1014	1.1/8		1.1/8		<b>6200-1014</b>	1.69	43	3.11	79
16	5/8	1.1/16	3/4	-1017	1.1/4	32	1.1/4	32	<b>6200-1017</b>	1.61	41	3.03	77
16	5/8	1.5/16	1	-1021	1.1/2	38	1.1/2	38	<b>6200-1021</b>	1.69	43	3.11	79
19	3/4	1.1/16	3/4	-1217	1.1/4	32	1.1/4	32	<b>6200-1217</b>	1.54	39	3.03	77
19	3/4	1.5/16	1	-1221	1.1/2	38	1.1/2	38	<b>6200-1221</b>	1.61	41	3.11	79
25	1	1.1/16	3/4	-1617	1.1/4	32	1.1/4	32	<b>6200-1617</b>	1.97	50	3.50	89
25	1	1.3/16	7/8	-1619	1.3/8		1.3/8		<b>6200-1619</b>	1.77	45	3.31	84
25	1	1.5/16	1	-1621	1.1/2	38	1.1/2	38	<b>6200-1621</b>	1.77	45	3.31	84

### UNO (O RING BOSS) 6390

O RING SUPPLIED

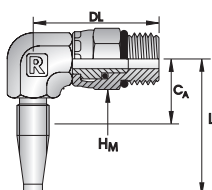

HOSE SIZE		THRD SIZE	TUBE SIZE	DASH SIZE	MALE HEX	UN O RING MALE SWIVEL 90° ELBOW								
DN	inch	inch	inch			HM-SPANNER		PART NO	CA		L		DL	
						inch	mm		inch	mm	inch	mm	inch	mm
6	1/4	9/16	3/8	-0409	9/16			<b>6390-0409</b>	1.06	27	2.09	53	1.38	35
6	1/4	3/4	1/2	-0412	3/4	19		<b>6390-0412</b>	1.10	28	2.17	55	1.65	42
10	3/8	9/16	3/8	-0609	3/4	19		<b>6390-0609</b>	0.98	25	2.28	58	1.50	38
10	3/8	3/4	1/2	-0612	3/4	19		<b>6390-0612</b>	0.98	25	2.28	58	1.65	42
10	3/8	7/8	5/8	-0614	7/8	22		<b>6390-0614</b>	1.02	26	2.32	59	1.77	45
12	1/2	3/4	1/2	-0812	7/8	22		<b>6390-0812</b>	1.26	32	2.56	65	1.73	44
12	1/2	7/8	5/8	-0814	7/8	22		<b>6390-0814</b>	1.26	32	2.56	65	1.77	45

**NOTE:** The "Live Swivel" 6390 Series Insert is for Maximum Working Pressure: 350 bar (5100 psi); -09 & -12 Thread Size, 280 bar (4100 psi); -14 & -17 Thread Size. Their swivel capability is to allow easy installation and orientation and avoid twisting of hose. They are not designed for continuous rotation or continuous movement.

**NOTE:** Hose Compatibility for the 6000 series can be found on page 353.

INTRODUCTION

HOSE

COUPLINGS

ADAPTORS

TECHNICAL

# ADAPTORS



THREAD OR CONNECTOR TYPE	MIXTURE	PAGE
<b>BSP</b>	BSPT/BSPP/BSPP O RING BSPT/JIC & BSPP O RING/JIC BSP/ORFS BSP/SAE BSP/UNO	399 - 414
<b>NPT &amp; NPSM</b>	NPT/NPT NPT/JIC NPT/ORFS NPT/SAE NPT/UNO & NPSM/UNO	415 - 421
<b>JIC</b>	JIC JIC/JIC JIC/ORFS JIC/UNO	422 - 431
<b>JOINER</b>	TUBEWELD/TUBEWELD	431
<b>METRIC*</b>	METRIC METRIC/BSPP O RING METRIC/JIC	432 - 435
<b>ORFS</b>	ORFS ORFS/ORFS ORFS/UNO	435 - 438
<b>SAE THREADS</b>	SAE SAE/SAE	439 - 443
<b>SAE FLANGES*</b>	SAE FLANGE CLAMPS & CLAMP KITS SAE FLANGE PLUGS & TUBE WELD SAE FLANGE/JIC SAE FLANGE/ORFS SAE FLANGE BLOCKS	444 - 448
<b>SWIVEL JOINTS</b>	BSP/BSP JIC/JIC	449
<b>UNO (O RING BOSS)</b>	UNO UNO/UNO	450
<b>MISCELLANEOUS</b>	O RINGS PLASTIC CAP AND PLUGS TUBE BENDS	451 - 457
<b>RYCOLOK &amp; SUPERLOK*</b>	RYCOLOK & SUPERLOK BALL VALVES	—
<b>RYCO WEO*</b>	RYCO WEO/RYCO WEO RYCO WEO/BSP RYCO WEO/JIC RYCO WEO/METRIC RYCO WEO/UNO	458 - 460

**NOTE:** If an ADAPTOR is available in both BSPT Male and BSPP O RING Male styles they are located close to each other.

INTRODUCTION

ADAPTORS

COUPLINGS

ADAPTORS

TECHNICAL

\*All adaptors with these thread or connector types are grouped together. The **METRIC, SAE FLANGE, RYCOLOK, SUPERLOK** or **RYCO WEO** end takes precedence. All METRIC adaptors, regardless of other end mixture, are in the METRIC group, and all SAE FLANGE adaptors are in SAE FLANGE group. Therefore a JIC/METRIC nipple will be found in METRIC Section not JIC Section; and an SAE FLANGE/BSP adaptor is in SAE FLANGE section not BSP section.

## WORKING PRESSURES – STEEL ADAPTORS

Since many factors influence the pressure at which a hydraulic system will, or will not, perform satisfactorily, Maximum Working Pressures should be used as a **guide only** and not as a “standard” nor “specification” nor construed as a “guaranteed minimum.” Unless otherwise listed below, refer to pages 494 to 498 for **Maximum Working Pressure** guide. For further technical assistance contact RYCO or your RYCO distributor.

**CAUTION:** The Maximum Working Pressure of an Adaptor with a combination of Thread / End Styles and sizes is the Maximum Working Pressure of the least rated end.

### **NOTE: DROP LENGTHS (DL) AND CUT-OFF ALLOWANCES (CA):**

Drop Lengths (DL) and Cut-off Allowances (CA) are in millimetres and are shown for reference only, and may vary according to manufacturing method, or due to design refinement.



# ADAPTORS

## FINDING ADAPTORS

There are three easy rules to remember to quickly find an ADAPTOR in this section. These are, in order:

### RULE 1. ALPHABETICAL RULE

The ADAPTORS section follows THREAD or CONNECTOR TYPE order and is in the "ALPHABETICAL" sequence shown on the Contents Page opposite. (This order is strictly alphabetical; except for NPT, which is similar in concept to BSP and is placed directly after BSP; and RYCOLOK, SUPERLOK and RYCO WEO which are placed at the end of the ADAPTORS section).

### RULE 2. MIXTURE RULE

Where there is a MIXTURE of THREAD or CONNECTOR TYPES eg. JIC one end UNO other end, this adaptor will be found in the JIC section (because JIC comes alphabetically before UNO). All the JIC/JIC adaptors come first, then JIC/ORFS then JIC/UNO.

There are SEVEN EXCEPTIONS to this MIXTURE rule:

**METRIC**  
**SAE FLANGE**  
**RYCOLOK**  
**SUPERLOK**  
**RYCO WEO**

In these cases, the **METRIC, SAE FLANGE, RYCOLOK, SUPERLOK** or **RYCO WEO** end takes precedence. All METRIC adaptors, regardless of other end mixture, are in the METRIC group, and all SAE FLANGE adaptors are in SAE FLANGE group. Therefore a JIC/METRIC nipple will be found in METRIC Section not JIC Section; and an SAE FLANGE/BSP adaptor is in SAE FLANGE section not BSP section.

### RULE 3. NUMBER OF ENDS RULE

Within each subsection the order is as follows:

#### FIND BY END NUMBER

<b>ONE ENDED ADAPTORS</b>	PLUG CAP	Male Plugs before Female Caps.
<b>TWO ENDED ADAPTORS</b>	TUBE WELD NUT & SLEEVE/NUT & OLIVE STRAIGHT 45° ELBOW 90° ELBOW 45° TUBE BEND 90° TUBE BEND	Male/Male before Male/Female before Female/Female
<b>THREE ENDED ADAPTORS</b>	TEE  Y	Male Tees before Male/Female Tees before Female Tees
<b>FOUR ENDED ADAPTORS</b>	CROSS X	

## OTHER WAYS TO QUICKLY FIND AN ADAPTOR

1. **CONTENTS PAGE** on page 387
2. **ALPHANUMERIC INDEX** on pages 4 and 5
3. **PICTORIAL INDEX** on pages 391 to 398

The PICTORIAL INDEX is in NUMBER OF ENDS rule order except 45° TUBE BENDS are after 45° ELBOWS, and 90° TUBE BENDS are after 90° ELBOWS.

All PLUGS first, then CAPS, TUBE WELDS, etc. finishing with CROSSES except all SAE FLANGES, SAE FLANGE BLOCKS and all RYCOLOK, SUPERLOK and RYCO WEO are at the end of the index.

## DASH SIZE NUMBERING RULES

The DASH SIZE numbering rules for HOSE and HOSE COUPLINGS are shown on pages 30 to 33, and are quite straightforward. With a little familiarity, you will find that you can specify Part Numbers without reference to the Product Technical Manual.

The DASH SIZE numbering rules for ADAPTORS are a little more complex, and are shown on this page, and the next page, for those who would like to understand the logic applied to determine the sequence ADAPTOR ends are listed.

Adaptors Dash Size numbering rules are very similar to the Three Rules on page 388. The main criteria is the **NUMBER OF ENDS** the Adaptor has, with other factors being **GENDER** (Male or Female) and **MIXTURE** of Thread or Connector type. Note also that BSPT, BSPP, and BSPP O RING are treated as "different" thread types.

### 1. ADAPTORS WITH ONE END. (Plugs and Caps, Lock Nuts, Bonded Seals etc.)

**RULE IS:** Adaptor Group Designator followed by Dash Size

**EXAMPLE:** **1/2" BSPT MALE PLUG**

Group Designator for BSPT Male Plug is S64 (from Pictorial Index page 391).

Dash Size for 1/2" BSP is -08 (see page 399).

**Part Number is S64-08.**



### 2. ADAPTORS WITH TWO ENDS. (Straights, Elbows, Tube Bends)

#### (A) SAME THREAD OR CONNECTOR TYPE. SAME GENDER

**RULE IS:** Larger Dash Size first, followed by smaller Dash Size.

(Except if a Bulkhead fitting, Bulkhead End first).

**EXAMPLE 1: 1/2" NPT MALE TO 3/4" NPT MALE NIPPLE**

Group Designator is S27N.

Dash Size for 1/2" NPT is -08. Dash Size for 3/4" NPT is -12.

**Part Number is S27N-1208.**

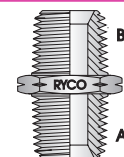

**Example 2: 1.1/16" JIC MALE BULKHEAD TO 7/8" JIC MALE NIPPLE**

Group Designator is S10.

Dash Size for 1.1/16" JIC is -17. Dash Size for 7/8" JIC is -14.

**Part Number is S10-1714.**

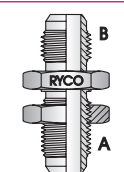

#### (B) SAME THREAD OR CONNECTOR TYPE. DIFFERENT GENDER

**RULE IS:** Dash Size of Male End first, then Dash Size of Female End.

**EXAMPLE:** **3/8" BSPT FEMALE TO 1/4" BSPT MALE 45° ELBOW**

Group Designator is S39.

Dash Size for 3/8" BSP is -06. Dash Size for 1/4" BSP is -04.

**Part Number is S39-0406.**

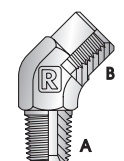

#### (C) TUBE WELD & NUT AND SLEEVE

Thread x Tube Weld **RULE IS:** Thread Dash Size First, then Tube Dash Size.

Flange x Tube Weld **RULE IS:** Flange Dash Size First, then Tube Dash Size.

Nut and Sleeve **RULE IS:** Thread Dash Size First, then Tube Dash Size.

**EXAMPLE 1: 1/2" BSPT MALE TO 3/4" TUBE OD TUBE WELD**

Group Designator is S53.

Dash Size for 1/2" BSP is -08. Dash Size for 3/4" OD Tube is -12.

**Part Number is S53-0812.**

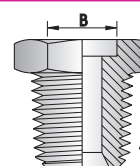

**EXAMPLE 2: JIC NUT AND SLEEVE FOR 3/8" TUBE OD**

Group Designator is S6.

Dash Size for 3/8" OD Tube is -06. JIC Thread Size for 3/8" Tube is 9/16" JIC (-09)

**Part Number is S6-0906.**

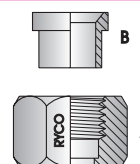

INTRODUCTION

ADAPTORS

COUPLINGS

ADAPTORS

TECHNICAL

# ADAPTORS

## DASH SIZE NUMBERING RULES

### (D) MIX OF THREAD OR CONNECTOR TYPES

**RULE IS:** In order shown below, which is alphabetical except for NPT, which comes immediately after BSP; and METRIC and SAE FLANGE are in groups (all METRIC, SAE FLANGE, RYCOLOK, SUPERLOK and RYCO WEO adaptors are grouped together regardless of the other end mixture).

THREAD OR CONNECTOR TYPE	MIXTURE	EXAMPLES
<b>BSP</b>	BSPT MALE BSPT MALE BULKHEAD BSPP MALE WITHOUT O RING BSPP ENCAPSULATED MALE BSPP O RING MALE BSPP FACE SEAL MALE BSPT FEMALE FIXED BSPP FEMALE FIXED BSPP FEMALE SWIVEL	<p><b>EXAMPLES:</b></p> <ol style="list-style-type: none"> <li><b>BSPT FEMALE TO JIC MALE ADAPTOR</b> BSPT End comes first</li> <li><b>UNO MALE TO JIC MALE</b> JIC End comes first</li> <li><b>NPT MALE to RYCOLOK FEMALE</b> <b>RYCOLOK</b> is a Group, so RYCOLOK End comes first</li> <li><b>JIC MALE TO DKL MALE</b> DKL is in <b>METRIC</b> Group so it comes first</li> <li>If adaptor is a mixture of "grouped" ends e.g. SAE Flange one end and Metric other, hierarchy is: <b>RYCOLOK</b> <b>SUPERLOK</b> <b>RYCO WEO</b> <b>SAE FLANGE</b> <b>METRIC</b></li> </ol> <p>Therefore Metric Male to SAE Flange would be in SAE Flange section and SAE Flange end comes first.</p>
<b>NPT</b>	NPT MALE NPT FEMALE FIXED NPSM FEMALE SWIVEL	
<b>JIC</b>	JIC MALE BULKHEAD JIC MALE JIC FEMALE FIXED JIC FEMALE SWIVEL	
<b>METRIC</b>	DKL MALE DKS MALE JIS (KOMATSU) MALE METRIC O RING BOSS	
<b>ORFS</b>	ORFS MALE BULKHEAD ORFS MALE ORFS FEMALE	
<b>SAE THREAD</b>	SAE MALE BULKHEAD SAE MALE SAE FEMALE	
<b>SAE FLANGE</b>	O RING GROOVED FLANGE FLAT FACED FLANGE (BLANK)	
<b>UNO (O RING BOSS)</b>	UNO RING MALE UNO FEMALE FIXED	
<b>RYCOLOK</b>	RYCOLOK MALE RYCOLOK FEMALE	
<b>SUPERLOK</b>	SUPERLOK MALE SUPERLOK FEMALE	
<b>RYCO WEO</b>	RYCO WEO MALE RYCO WEO FEMALE	

### (E) SWIVEL JOINTS

**RULE IS:** The Dash Size of Thread on the centre spindle comes first, and Dash Size of Thread on the rotating body comes second.

#### 3. ADAPTORS WITH THREE ENDS. (Tees & Y's)

##### Always numbered in order

- Dash Size of Run End A
- Dash Size of Run End B
- Dash Size of Branch End C

**RULES FOR DETERMINING WHICH OF RUN END A OR RUN END B COMES FIRST ARE SAME RULES AS FOR ADAPTORS WITH TWO ENDS (ABOVE).**

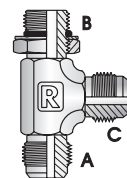

#### 4. ADAPTORS WITH FOUR ENDS. (Crosses & X's)

- S32 BSPT Female Cross
- S32N NPT Female Cross
- S100 JIC Male Cross

only, no jump sizes & no mixes of threads.

**RULE IS: Start at first end A, and then proceed clockwise.**

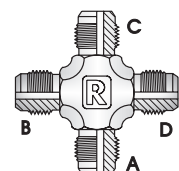

INTRODUCTION

ADAPTORS

COUPLINGS

ADAPTORS

TECHNICAL

**PLUG**

<b>S64</b> P399	<b>S73</b> P399	<b>S64N</b> P415	<b>S56</b> P422	<b>M73</b> P432	<b>S111</b> P435	<b>S97</b> P450
BSPT MALE PLUG	BSPP ENCAPSULATED MALE PLUG	NPT MALE PLUG	JIC MALE PLUG	METRIC MALE PLUG	ORFS MALE PLUG	UN O RING MALE PLUG

**PLUG CONT'D**

<b>S97AK</b> P450	<b>RW723</b> P458
UN O RING MALE ALLEN KEY HEAD PLUG	RYCO WEO MALE PLUG

**CAP**

<b>S59</b> P399	<b>S65</b> P422	<b>S65S</b> P422	<b>S113</b> P435	<b>RW811</b> P458
BSPP FEMALE SWIVEL CAP	JIC FEMALE CAP	JIC FEMALE SWIVEL CAP	ORFS FEMALE CAP	RYCO WEO FEMALE STOP CAP

**TUBE WELD WELD ON**

<b>S53</b> P399	<b>S53P</b> P399	<b>S54</b> P399	<b>S58</b> P399	<b>S53N</b> P415	<b>S51</b> P422	<b>S52</b> P422
BSPT MALE TUBE WELD	BSPP MALE TUBE WELD	BSPT MALE TUBE WELD 90° ELBOW	BSPP FEMALE SWIVEL TUBE WELD	NPT MALE TUBE WELD	JIC MALE TUBE WELD	JIC MALE TUBE WELD 90° ELBOW

**TUBE WELD WELD ON CONT'D**

<b>S57</b> P422	<b>S152</b> P422	<b>S112</b> P431	<b>S115</b> P435	<b>S106</b> P435	<b>SA51</b> P439	<b>S148</b> P450
JIC FEMALE SWIVEL TUBE WELD	JIC MALE TUBE WELD TEE	JOINER TUBE WELD	ORFS MALE TUBE WELD	ORFS FEMALE SWIVEL TUBE WELD	SAE MALE TUBE WELD	UN O RING FEMALE HALF SOCKET WELD ON

**NUT & SLEEVE**

**NUT & OLIVE**

<b>S6</b> P423	<b>S6M</b> P423	<b>S6S</b> P423	<b>S134</b> P423	<b>M6L</b> P432	<b>M6S</b> P432	<b>SA6</b> P439
JIC FEMALE NUT & SLEEVE	JIC FEMALE NUT & METRIC SLEEVE	JIC FEMALE NUT & SHORT SLEEVE	J-LOK NUT & OLIVE	METRIC DKL NUT & OLIVE	METRIC DKS NUT & OLIVE	SAE FEMALE NUT & SLEEVE







**BULKHEAD NIPPLE**

<b>S44</b> P401	<b>S130</b> P406	<b>S130P</b> P406	<b>S10</b> P424	<b>S141</b> P436	<b>SA10</b> P439
BSPP MALE BULKHEAD BSPP MALE	BSPTM NO SEAT JIC MALE BULKHEAD	BSPP MALE JIC MALE BULKHEAD	JIC MALE BULKHEAD JIC MALE	ORFS MALE BULKHEAD ORFS MALE	SAE MALE BULKHEAD SAE MALE





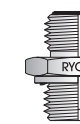

# ADAPTORS

## PICTORIAL INDEX







### MALE NIPPLE

<b>S27</b> P400	<b>S75</b> P401	<b>S46</b> P402	<b>S7</b> P407	<b>S74</b> P409	<b>S180</b> P412	<b>SA7</b> P412
						
BSPT MALE BSPT MALE	BSPT MALE BSPP ENCAPSULATED MALE	BSPP MALE BSPP ENCAPSULATED MALE	BSPT MALE JIC MALE	BSPP ENCAPSULATED MALE JIC MALE	BSPP ENCAPSULATED MALE ORFS MALE	BSPT MALE SAE MALE





### MALE NIPPLE CONT'D

<b>S93</b> P413	<b>S27N</b> P416	<b>S7N</b> P418	<b>S114N</b> P420	<b>SA7N</b> P421	<b>S17</b> P424	<b>S108</b> P428
						
BSPT MALE UN O RING MALE	NPT MALE NPT MALE	NPT MALE JIC MALE	NPT MALE ORFS MALE	NPT MALE SAE MALE	JIC MALE JIC MALE	JIC MALE ORFS MALE



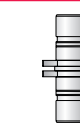
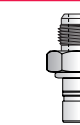
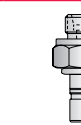

### MALE NIPPLE CONT'D

<b>S90</b> P429	<b>S107</b> P429	<b>M75L</b> P433	<b>M75S</b> P433	<b>M7</b> P434	<b>M7L</b> P434	<b>M7S</b> P434
						
JIC MALE UN O RING MALE	JIC MALE EXTENDED UN O RING MALE	METRIC DKL MALE 24° CONE BSPP O RING MALE	METRIC DKS MALE 24° CONE BSPP O RING MALE	METRIC MALE JIC MALE	METRIC DKL MALE 24° CONE JIC MALE	METRIC DKS MALE 24° CONE JIC MALE

### MALE NIPPLE CONT'D

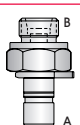





<b>S116</b> P436	<b>S122</b> P437	<b>SA17</b> P439	<b>S162</b> P450	<b>RW722</b> P458	<b>RW727</b> P459	<b>RW725</b> P459
						
ORFS MALE ORFS MALE	ORFS MALE UN O RING MALE	SAE MALE SAE MALE	UN O RING MALE ADJUSTABLE UN O RING MALE	RYCO WEO MALE MALE NIPPLE	RYCO WEO MALE JIC MALE	RYCO WEO MALE DKL MALE

### MALE NIPPLE CONT'D

<b>RW726</b> P460	<b>S24</b> P400	<b>S102</b> P402	<b>S85</b> P413	<b>S24N</b> P415
				
RYCO WEO MALE DKS MALE	BSPT MALE BSPT FEMALE FIXED REDUCING BUSH	BSPP ENCAPSULATED MALE BSPP FEMALE FIXED REDUCING BUSH	BSPT FEMALE FIXED UN O RING MALE REDUCING BUSH	NPT MALE NPT FEMALE FIXED REDUCING BUSH

### REDUCING BUSH

### STRAIGHT MALE X FEMALE

<b>S72</b> P400	<b>S80</b> P400	<b>S43</b> P402	<b>S128</b> P407	<b>S61</b> P407	<b>S16</b> P407	<b>S71</b> P409
						
BSPT MALE BSPT FEMALE FIXED	BSPT MALE BSPP FEMALE SWIVEL	BSPP ENCAPSULATED MALE BSPP FEMALE SWIVEL	BSPT MALE JIC/UN O RING FEMALE FIXED DUAL SEAT	BSPT MALE JIC FEMALE SWIVEL	BSPT FEMALE FIXED JIC MALE	BSPP ENCAPSULATED MALE JIC FEMALE SWIVEL

INTRODUCTION

STRAIGHT  
MALE X  
FEMALE  
CONT'D

<b>S181</b> P412	<b>S96</b> P413	<b>S95</b> P414	<b>S72N</b> P416	<b>S80N</b> P416	<b>S61N</b> P418	<b>S16N</b> P418
BSPP ENCAPSULATED MALE ORFS FEMALE SWIVEL	BSPT FEMALE FIXED UN O RING MALE	BSPP FEMALE SWIVEL UN O RING MALE	NPT MALE NPT FEMALE FIXED	NPT MALE NPSM FEMALE SWIVEL	NPT MALE JIC FEMALE SWIVEL	NPT FEMALE FIXED JIC MALE

ADAPTORS

STRAIGHT  
MALE X  
FEMALE  
CONT'D

<b>S96N</b> P421	<b>S95N</b> P421	<b>S66F</b> P424	<b>S66</b> P424	<b>S109</b> P428	<b>S110</b> P428	<b>S101</b> P429
NPT FEMALE FIXED UN O RING MALE	NPSM FEMALE SWIVEL UN O RING MALE	JIC MALE JIC FEMALE FIXED REDUCER	JIC MALE JIC FEMALE REDUCER	JIC MALE ORFS FEMALE SWIVEL	JIC FEMALE SWIVEL ORFS MALE	JIC FEMALE SWIVEL UN O RING MALE

COUPLINGS

STRAIGHT  
MALE X  
FEMALE  
CONT'D

<b>M71L</b> P435	<b>M71S</b> P435	<b>RW721</b> P459	<b>RW830</b> P459	<b>RW824</b> P459	<b>RW822</b> P459	<b>RW823</b> P460
METRIC DKL MALE 24° CONE JIC FEMALE SWIVEL	METRIC DKS MALE 24° CONE JIC FEMALE SWIVEL	RYCO WEO FEMALE BSPP FEMALE	RYCO WEO FEMALE BSPP ENCAPSULATED MALE	RYCO WEO FEMALE JIC MALE	RYCO WEO FEMALE DKL MALE	RYCO WEO FEMALE DKS MALE

ADAPTORS

STRAIGHT  
MALE X  
FEMALE  
CONT'D

<b>RW831</b> P460	<b>RW826</b> P460	<b>RW860</b> P459
RYCO WEO FEMALE METRIC MALE O RING BOSS	RYCO WEO FEMALE UN O RING MALE	RYCO WEO FEMALE SWIVEL BSPP ENCAPSULATED MALE

TECHNICAL

STRAIGHT  
FEMALE X  
FEMALE

<b>S26</b> P401	<b>S81</b> P401	<b>S26N</b> P416	<b>S81N</b> P416	<b>S163</b> P450	<b>RW813</b> P458
BSPT FEMALE SOCKET	BSPT FEMALE FIXED BSPP FEMALE SWIVEL	NPT FEMALE SOCKET	NPT FEMALE FIXED NPSM FEMALE SWIVEL	UN O RING FEMALE SOCKET	RYCO WEO FEMALE BULKHEAD

45° ELBOW  
MALE X  
MALE

<b>S45</b> P403	<b>S9</b> P408	<b>S69</b> P410	<b>SA9</b> P412	<b>S60</b> P414	<b>S9N</b> P419	<b>SA9N</b> P421
BSPT MALE BSPT MALE 45° ELBOW	BSPT MALE JIC MALE 45° ELBOW	BSPP O RING MALE JIC MALE 45° ELBOW	BSPT MALE SAE MALE 45° ELBOW	BSPT MALE UN O RING MALE 45° ELBOW	NPT MALE JIC MALE 45° ELBOW	NPT MALE SAE MALE 45° ELBOW

45° ELBOW  
MALE X  
MALE  
CONT'D







<b>S88</b> P430	<b>S123</b> P437
JIC MALE UN O RING MALE 45° ELBOW	ORFS MALE UN O RING MALE 45° ELBOW



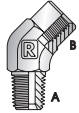

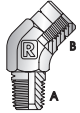
# ADAPTORS

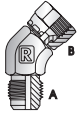
## PICTORIAL INDEX



**45° ELBOW  
MALE X  
FEMALE**

<b>S39</b> P403	<b>S84</b> P403	<b>S39N</b> P417	<b>S84N</b> P417	<b>S23</b> P424	<b>SA23</b> P439
					
BSPT MALE BSPT FEMALE FIXED 45° ELBOW	BSPT MALE BSPP FEMALE SWIVEL 45° ELBOW	NPT MALE NPT FEMALE FIXED 45° ELBOW	NPT MALE NPSM FEMALE SWIVEL 45° ELBOW	JIC MALE JIC FEMALE 45° ELBOW	SAE MALE SAE FEMALE SWIVEL 45° ELBOW

**45° ELBOW  
FEMALE X  
FEMALE**

<b>S31</b> P403	<b>S31N</b> P417
	
BSPT FEMALE FIXED BSPT FEMALE FIXED 45° ELBOW	NPT FEMALE FIXED NPT FEMALE FIXED 45° ELBOW



**45°  
TUBE BEND  
FEMALE X  
FEMALE**

<b>S5</b> P425	<b>S138</b> P428
	
JIC MALE JIC FEMALE SWIVEL 45° TUBE BEND	JIC MALE ORFS FEMALE SWIVEL 45° TUBE BEND

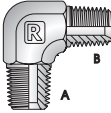
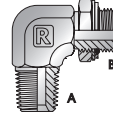
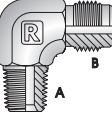
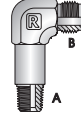
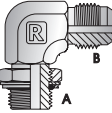
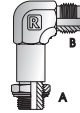
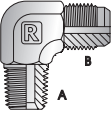

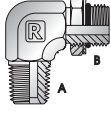
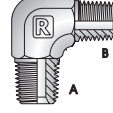
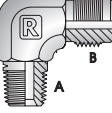
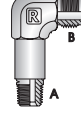
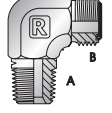

**90° ELBOW  
MALE X  
MALE**

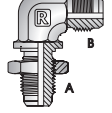
<b>S49</b> P403	<b>S77</b> P404	<b>S8</b> P408	<b>S11</b> P408	<b>S76</b> P410	<b>S70</b> P410	<b>SA8</b> P412
						
BSPT MALE BSPT MALE 90° ELBOW	BSPT MALE BSPP O RING MALE 90° ELBOW	BSPT MALE JIC MALE 90° ELBOW	BSPT MALE EXTENDED JIC MALE 90° ELBOW	BSPP O RING MALE JIC MALE 90° ELBOW	BSPP O RING MALE EXTENDED JIC MALE 90° ELBOW	BSPT MALE SAE MALE 90° ELBOW

**90° ELBOW  
MALE X  
MALE  
CONT'D**

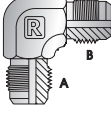
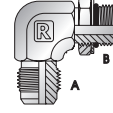
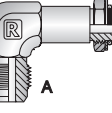
<b>S89</b> P414	<b>S49N</b> P417	<b>S8N</b> P419	<b>S11N</b> P419	<b>S145N</b> P420	<b>SA8N</b> P421	<b>S13</b> P425
						
BSPT MALE UN O RING MALE 90° ELBOW	NPT MALE NPT MALE 90° ELBOW	NPT MALE JIC MALE 90° ELBOW	NPT MALE EXTENDED JIC MALE 90° ELBOW	NPT MALE ORFS MALE 90° ELBOW	NPT MALE SAE MALE 90° ELBOW	JIC MALE BULKHEAD JIC MALE 90° ELBOW

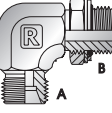
**90° ELBOW  
MALE X  
MALE  
CONT'D**

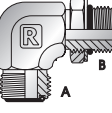
<b>S18</b> P425	<b>S91</b> P430	<b>S12</b> P431	<b>M77L</b> P433	<b>M77S</b> P433	<b>S117</b> P436	<b>S124</b> P437
						
JIC MALE JIC MALE 90° ELBOW	JIC MALE UN O RING MALE 90° ELBOW	JIC MALE UN O RING MALE EXTENDED 90° ELBOW	METRIC DKL MALE BSPP O RING MALE 90° ELBOW	METRIC DKS MALE BSPP O RING MALE 90° ELBOW	ORFS MALE ORFS MALE 90° ELBOW	ORFS MALE UN O RING MALE 90° ELBOW

**90° ELBOW  
MALE X  
MALE  
CONT'D**

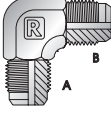
<b>SA18</b> P439

SAE MALE SAE MALE 90° ELBOW



INTRODUCTION

ADAPTORS

COUPLINGS

ADAPTORS

TECHNICAL

**90° ELBOW  
MALE X  
FEMALE**

<b>S25</b> P403	<b>S82</b> P403	<b>S105</b> P404	<b>S94</b> P414	<b>S25N</b> P417	<b>S82N</b> P417	<b>S94N</b> P421
BSPT MALE BSPT FEMALE FIXED 90° ELBOW	BSPT MALE BSPP FEMALE SWIVEL 90° ELBOW	BSPP O RING MALE BSPP FEMALE SWIVEL 90° ELBOW	BSPP FEMALE SWIVEL UN O RING MALE 90° ELBOW	NPT MALE NPT FEMALE FIXED 90° ELBOW	NPT MALE NPSM FEMALE SWIVEL 90° ELBOW	NPSM FEMALE SWIVEL UN O RING MALE 90° ELBOW

**90° ELBOW  
MALE X  
FEMALE  
CONT'D**

<b>S15</b> P425	<b>S86</b> P430	<b>S118</b> P436	<b>S125</b> P437	<b>SA15</b> P439
JIC MALE JIC FEMALE SWIVEL 90° ELBOW	JIC FEMALE SWIVEL UN O RING MALE 90° ELBOW	ORFS MALE ORFS FEMALE SWIVEL 90° ELBOW	ORFS FEMALE SWIVEL UN O RING MALE 90° ELBOW	SAE MALE SAE FEMALE SWIVEL 90° ELBOW

**90° ELBOW  
FEMALE X  
FEMALE**

<b>S28</b> P403	<b>S28N</b> P417	<b>90° TUBE BEND</b>		<b>S4</b> P425	<b>S103</b> P425	<b>S137</b> P428	<b>S154</b> P436
BSPT FEMALE BSPT FEMALE FIXED 90° ELBOW	NPT FEMALE FIXED NPT FEMALE FIXED 90° ELBOW			JIC MALE JIC FEMALE SWIVEL 90° TUBE BEND	JIC MALE JIC FEMALE SWIVEL 90° LONG BEND	JIC MALE ORFS FEMALE SWIVEL 90° TUBE BEND	ORFS MALE ORFS FEMALE SWIVEL 90° TUBE BEND

**TEE  
MALE X  
MALE**

<b>S50</b> P405	<b>S104</b> P406	<b>S135</b> P406	<b>S21</b> P411	<b>S78</b> P411	<b>S20</b> P411	<b>S79</b> P411
BSPT MALE BSPT MALE BSPT MALE	BSPT MALE BSPP O RING MALE BSPT MALE	BSPT MALE BSPT MALE BSPP O RING MALE	BSPT MALE JIC MALE JIC MALE	BSPP O RING MALE JIC MALE JIC MALE	JIC MALE JIC MALE BSPT MALE	JIC MALE JIC MALE BSPP O RING MALE

**TEE  
MALE X  
MALE  
CONT'D**

<b>SA20</b> P412	<b>S50N</b> P417	<b>S21N</b> P420	<b>S20N</b> P420	<b>SA20N</b> P421	<b>S19</b> P426	<b>S62</b> P426
SAE MALE SAE MALE BSPT MALE	NPT MALE NPT MALE NPT MALE	NPT MALE JIC MALE JIC MALE	JIC MALE JIC MALE NPT MALE	SAE MALE SAE MALE NPT MALE	JIC MALE JIC MALE JIC MALE	JIC BULKHEAD JIC MALE JIC MALE

**TEE  
MALE X  
MALE  
CONT'D**

<b>S63</b> P426	<b>S92</b> P431	<b>S87</b> P431	<b>S119</b> P437	<b>S126</b> P438	<b>S127</b> P438	<b>SA19</b> P440
JIC MALE JIC MALE JIC BULKHEAD	JIC MALE JIC MALE UN O RING MALE	JIC MALE UN O RING MALE JIC MALE	ORFS MALE ORFS MALE ORFS MALE	ORFS MALE ORFS MALE UN O RING MALE	ORFS MALE UN O RING MALE ORFS MALE	SAE MALE SAE MALE SAE MALE

# ADAPTORS

## PICTORIAL INDEX

### TEE MALE X FEMALE

S48 P405	S167 P405	S47 P405	S83 P405	S48N P417	S47N P417	S68 P427
BSPT MALE BSPT FEMALE FIXED BSPT FEMALE FIXED	BSPT MALE BSPP FEMALE SWIVEL BSPT MALE	BSPT FEMALE FIXED BSPT FEMALE FIXED BSPT MALE	BSPP FEMALE SWIVEL BSPP FEMALE SWIVEL BSPT MALE	NPT MALE NPT FEMALE FIXED NPT FEMALE FIXED	NPT FEMALE FIXED NPT FEMALE FIXED NPT MALE	JIC MALE JIC MALE JIC FEMALE SWIVEL

### TEE MALE X FEMALE CONT'D

S67 P427	S120 P437	S121 P437	S29 P406	S139 P406	S29N P417
JIC MALE JIC FEMALE SWIVEL JIC MALE	ORFS MALE ORFS MALE ORFS FEMALE SWIVEL	ORFS MALE ORFS FEMALE SWIVEL ORFS MALE	BSPT FEMALE FIXED BSPT FEMALE FIXED BSPT FEMALE FIXED	BSPP FEMALE FIXED BSPP FEMALE FIXED BSPP FEMALE FIXED	NPT FEMALE FIXED NPT FEMALE FIXED NPT FEMALE FIXED

### TEE FEMALE X FEMALE

### CROSS

S32 P406	S32N P417	S100 P427
BSPT FEMALE FIXED CROSS	NPT FEMALE FIXED CROSS	JIC MALE CROSS

### SAE FLANGE CLAMPS & KITS CODE 61

S40 P440	S140 P440	S40K P440	S140K P440	S40M P441	S140M P441
SPLIT FLANGE CLAMPS CODE 61 SUPPLIED IN PAIRS	SOLID FLANGE CLAMP CODE 61	UNC BOLTS SPLIT FLANGE CLAMP KITS CODE 61	UNC BOLTS SOLID FLANGE CLAMP KITS CODE 61	METRIC BOLTS SPLIT FLANGE CLAMP KITS CODE 61	METRIC BOLTS SOLID FLANGE CLAMP KITS CODE 61

### SAE FLANGE CLAMPS & KITS CODE 62

S42 P440	S142 P440	S42K P440	S142K P440	S42M P441	S142M P441
SPLIT FLANGE CLAMPS CODE 62 SUPPLIED IN PAIRS	SOLID FLANGE CLAMP CODE 62	UNC BOLTS SPLIT FLANGE CLAMP KITS CODE 62	UNC BOLTS SOLID FLANGE CLAMP KITS CODE 62	METRIC BOLTS SPLIT FLANGE CLAMP KITS CODE 62	METRIC BOLTS SOLID FLANGE CLAMP KITS CODE 62

### SAE FLANGE PLUG & TUBE WELD

S979 P442	S980 P442	S981 P442	S982 P442	S982C P442
BLANK PLUG CODE 61	BLANK PLUG CODE 62	CODE 61 O RING FACE SOCKET WELD	CODE 62 O RING FACE SOCKET WELD	RYCO CODE 62C O RING FACE SOCKET WELD

INTRODUCTION

ADAPTORS

COUPLINGS

ADAPTORS

TECHNICAL

### SAE FLANGE JIC ADAPTORS

<b>S1</b> P443	<b>S3</b> P443	<b>S2</b> P443	<b>S2L</b> P443	<b>S1H</b> P443	<b>S3H</b> P443	<b>S2H</b> P443
CODE 61 FLANGE JIC MALE	CODE 61 FLANGE JIC MALE 45° TUBE BEND	CODE 61 FLANGE JIC MALE 90° TUBE BEND	CODE 61 FLANGE JIC MALE 90° LONG BEND	CODE 62 FLANGE JIC MALE	CODE 62 FLANGE JIC MALE 45° TUBE BEND	CODE 62 FLANGE JIC MALE 90° TUBE BEND

### SAE FLANGE ORFS ADAPTORS

<b>S147H</b> P444	<b>S146H</b> P444	<b>S143H</b> P444
CODE 62 FLANGE ORFS MALE	CODE 62 FLANGE ORFS MALE 45° TUBE BEND	CODE 62 FLANGE ORFS MALE 90° TUBE BEND

### SAE FLANGE BLOCKS CODE 61 BLIND & WELD

<b>S967</b> P445	<b>S940</b> P445	<b>S940F &amp; FM</b> P445	<b>S970</b> P446	<b>S970F &amp; FM</b> P446	<b>S976</b> P446	<b>S976F</b> P446
CODE 61 FLANGE BLIND	CODE 61 FLANGE SOCKET WELD TUBE	CODE 61 FLANGE FLAT SOCKET WELD TUBE	CODE 61 FLANGE SOCKET WELD PIPE	CODE 61 FLANGE FLAT SOCKET WELD PIPE	CODE 61 FLANGE BUTT WELD PIPE	CODE 61 FLANGE FLAT BUTT WELD PIPE

### SAE FLANGE BLOCKS CODE 62 BLIND & WELD

<b>S968</b> P445	<b>S941</b> P445	<b>S941F &amp; FM</b> P445	<b>S971</b> P446	<b>S971F &amp; FM</b> P446	<b>S977</b> P446	<b>S977F</b> P446
CODE 62 FLANGE BLIND	CODE 62 FLANGE SOCKET WELD TUBE	CODE 62 FLANGE FLAT SOCKET WELD TUBE	CODE 62 FLANGE SOCKET WELD PIPE	CODE 62 FLANGE FLAT SOCKET WELD PIPE	CODE 62 FLANGE BUTT WELD PIPE	CODE 62 FLANGE FLAT BUTT WELD PIPE

### SAE FLANGE BLOCKS CODE 61

<b>S951</b> P447	<b>S951F &amp; FM</b> P447	<b>S953</b> P447	<b>S957</b> P448
CODE 61 FLANGE BSPP FEMALE	CODE 61 FLANGE FLAT BSPP FEMALE	CODE 61 FLANGE BSPP MALE	CODE 61 FLANGE JIC MALE

### SAE FLANGE BLOCK FASTENING KIT

<b>FK61 &amp; M</b> P444
SUITS SAE FLANGE BLOCKS CODE 61

### SAE FLANGE BLOCKS CODE 62

<b>S952</b> P447	<b>S952F &amp; FM</b> P447	<b>S954</b> P447	<b>S958</b> P448
CODE 62 FLANGE BSPP FEMALE	CODE 62 FLANGE FLAT BSPP FEMALE	CODE 62 FLANGE BSPP MALE	CODE 62 FLANGE JIC MALE

### SAE FLANGE BLOCK FASTENING KIT

<b>FK62 &amp; M</b> P444
SUITS SAE FLANGE BLOCKS CODE 62

### SWIVEL JOINTS

<b>S37</b> P449	<b>S36</b> P449	<b>S131</b> P449	<b>S33</b> P449	<b>S34</b> P449	<b>S35</b> P449	<b>SJK/RKS</b> P449
BSPT MALE BSPT MALE 90° SWIVEL JOINT	BSPT MALE BSPP FEMALE SWIVEL 90° SWIVEL JOINT	JIC MALE JIC FIXED FEMALE SWIVEL JOINT	JIC MALE JIC MALE 90° SWIVEL JOINT	JIC MALE JIC FEMALE 90° SWIVEL JOINT	JIC FEMALE JIC MALE 90° SWIVEL JOINT	REPLACEMENT SEAL KIT

	O-RING
	RUBBER WASHER
	TEFLON BACKSTOP
	O-RING
	TEFLON BACKSTOP
	RUBBER WASHER

# ADAPTORS

## PICTORIAL INDEX

### O RINGS

ROD-AC P451	ROD-BP P451	ROD-DL P451	ROD-DS P451	ROD-FS P451	ROD-SF P452	ROD-UN P452
AIR CONDITIONING PILOT FITTING 70 DUROMETER (GREEN HNBR)	BSPP O RING MALE THREAD 90 DUROMETER	DKOL FEMALE METRIC 70 DUROMETER	DKOS FEMALE METRIC 70 DUROMETER	ORFS 90 DUROMETER	SAE FLANGE 90 DUROMETER	UNO THREAD 90 DUROMETER

### O RINGS CONT'D

ROD-WD/BE P452	COMPONENTS & ACCESSORIES		35B P404	36B P404	35/37 P427	MBD P432	RL21D P404
BSPP ENCAPSULATED MALE SEAL			BSPP LOCK NUT	BSPP RETAINING RING	JIC LOCK NUT	METRIC METAL BONDED SEAL W/ CENTRALISING LIP	BSPP METAL BONDED SEAL W/ CENTRALISING LIP

### COMPONENTS & ACCESSORIES CONT'D

BBB P461	BBM P461	RL20SH P461
BSP BANJO BOLT	METRIC BANJO BOLT	BALL VALVE BSPP FEMALE BSPP FEMALE

### PLASTIC PROTECTORS

BPD P453	BCD P453	JPD P453	JCD P453	JCTD P453	MPD P454	MCD P454
PLUG SUITS FEMALE BSP & NPSM	CAP SUITS MALE BSP & NPT	PLUG SUITS FEMALE JIC, SAE & UNO	CAP SUITS MALE JIC, SAE & UNO	TEAR OFF CAP SUITS MALE JIC, SAE & UNO	PLUG SUITS FEMALE METRIC	CAP SUITS MALE METRIC

### PLASTIC PROTECTORS CONT'D

OPD P454	OCD P454	FC61D P455	FC62D P455	PPD P455
PLUG SUITS FEMALE ORFS	CAP SUITS MALE ORFS	SUITS SAE CODE 61 FLANGE	SUITS SAE CODE 62 & R62C FLANGE	SUITS 800 SERIES FITTING

### TUBE BENDS IMPERIAL OUTSIDE DIAMETER

14 P456	15 P456	25 P456	25HL P456	17 P456	16 P456
22.5° TUBE BEND	30° TUBE BEND	45° TUBE BEND	45° TUBE BEND HEAVY	60° TUBE BEND	67.5° TUBE BEND

### TUBE BENDS IMPERIAL OUTSIDE DIAMETER CONT'D

24A P457	24B P457	24 P457	24HL P457	21 P457	91 P457
90° SPECIAL LONG TUBE BEND	90° SPECIAL LONG TUBE BEND	90° TUBE BEND	90° TUBE BEND HEAVY	90° LONG TUBE BEND	110° LONG TUBE BEND

<b>BSP</b>	<b>S64</b>	<b>S59</b>	<b>BSPP</b>	<b>S73</b>
------------	------------	------------	-------------	------------

**PLUG  
CAP**

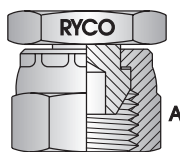
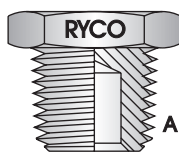

**PLUG  
SEAL SUPPLIED**



INTRODUCTION

THREAD A	DASH SIZE	BSPT MALE PLUG	BSPP FEMALE SWIVEL CAP
inch		PART NO	PART NO
1/8	-02	S64-02	S59-02
1/4	-04	S64-04	S59-04
3/8	-06	S64-06	S59-06
1/2	-08	S64-08	S59-08
3/4	-12	S64-12	S59-12
1	-16	S64-16	S59-16
1.1/4	-20	S64-20	S59-20
1.1/2	-24	S64-24	S59-24
2	-32	S64-32	S59-32

THREAD A	DASH SIZE	BSPP ENCAPSULATED MALE PLUG
inch		PART NO
1/8	-02	S73-02
1/4	-04	S73-04
3/8	-06	S73-06
1/2	-08	S73-08
3/4	-12	S73-12
1	-16	S73-16
1.1/4	-20	S73-20
1.1/2	-24	S73-24
2	-32	S73-32

ADAPTORS

COUPLINGS

**NOTE:** S73 was previously O Ring & Retaining Ring design. Stock of previous design may exist and may be supplied.

<b>BSP</b>	<b>S53</b>	<b>S53P</b>	<b>S54</b>	<b>S58</b>
------------	------------	-------------	------------	------------

**TUBE WELD**

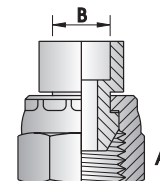
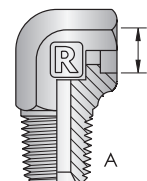
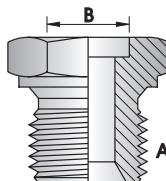
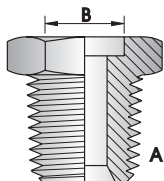

ADAPTORS

THREAD A	TUBE OD B	DASH SIZE	BSPT MALE TUBE WELD	BSPP MALE TUBE WELD	BSPT MALE TUBE WELD 90° ELBOW	BSPP FEM SWIVEL TUBE WELD
inch	inch		PART NO	PART NO	PART NO	PART NO
1/4	3/8	-0406	S53-0406		S54-0406	S58-0406
3/8	3/8	-0606	S53-0606			S58-0606
3/8	1/2	-0608	S53-0608		S54-0608	
3/8	5/8	-0610			S54-0610	
1/2	1/2	-0808	S53-0808	S53P-0808	S54-0808	S58-0808
1/2	5/8	-0810	S53-0810	S53P-0810	S54-0810	
1/2	3/4	-0812	S53-0812		S54-0812	
3/4	3/4	-1212	S53-1212		S54-1212	S58-1212
3/4	7/8	-1214	S53-1214		S54-1214	
3/4	1	-1216	S53-1216			
1	1	-1616	S53-1616		S54-1616	S58-1616
1	1.1/4	-1620	S53-1620			
1.1/4	1.1/4	-2020	S53-2020			S58-2020
1.1/2	1.1/2	-2424	S53-2424			S58-2424
1.1/2	1.15/16	-2431	S53-2431			
2	2	-3232				S58-3232

TECHNICAL

# ADAPTORS

## BSP ADAPTORS

BSP/BSP	S27	S24	S72	S80
---------	-----	-----	-----	-----

STRAIGHT

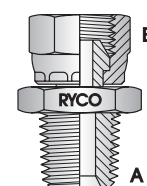
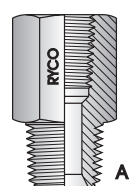
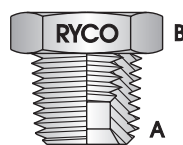
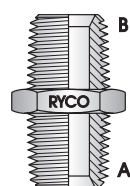

THREAD		DASH SIZE	BSPT MALE BSPT MALE	BSPT MALE BSPT FEMALE FIXED REDUCING BUSH	BSPT MALE BSPT FEMALE FIXED	BSPT MALE BSPP FEMALE SWIVEL
A	B					
inch	inch		PART NO	PART NO	PART NO	PART NO
1/8	1/8	-0202	S27-0202		S72-0202	S80-0202
1/8	1/4	-0204			S72-0204	
1/4	1/8	-0402	S27-0402	S24-0402		
1/4	1/4	-0404	S27-0404		S72-0404	S80-0404
1/4	3/8	-0406			S72-0406	
3/8	1/8	-0602		S24-0602		
3/8	1/4	-0604	S27-0604	S24-0604		
3/8	3/8	-0606	S27-0606		S72-0606	S80-0606
3/8	1/2	-0608			S72-0608	S80-0608
1/2	1/8	-0802		S24-0802		
1/2	1/4	-0804	S27-0804	S24-0804		
1/2	3/8	-0806	S27-0806	S24-0806		S80-0806
1/2	1/2	-0808	S27-0808		S72-0808	S80-0808
1/2	3/4	-0812			S72-0812	S80-0812
5/8	1/2	-1008	S27-1008			
5/8	5/8	-1010	S27-1010			
3/4	1/4	-1204		S24-1204		
3/4	3/8	-1206	S27-1206	S24-1206		
3/4	1/2	-1208	S27-1208	S24-1208		
3/4	5/8	-1210	S27-1210			
3/4	3/4	-1212	S27-1212		S72-1212	S80-1212
3/4	1	-1216				S80-1216
1	3/8	-1606		S24-1606		
1	1/2	-1608	S27-1608	S24-1608		
1	3/4	-1612	S27-1612	S24-1612		S80-1612
1	1	-1616	S27-1616		S72-1616	S80-1616
1	1	-1616	S27H-1616*			
1.1/4	1/2	-2008		S24-2008		
1.1/4	3/4	-2012	S27-2012	S24-2012		
1.1/4	1	-2016	S27-2016	S24-2016		
1.1/4	1.1/4	-2020	S27-2020			S80-2020
1.1/2	1/2	-2408		S24-2408		
1.1/2	3/4	-2412	S27-2412	S24-2412		
1.1/2	1	-2416	S27-2416	S24-2416		
1.1/2	1.1/4	-2420	S27-2420	S24-2420		
1.1/2	1.1/2	-2424	S27-2424			
2	1	-3216		S24-3216		
2	1.1/4	-3220	S27-3220			
2	1.1/2	-3224	S27-3224	S24-3224		
2	2	-3232	S27-3232			

NOTE: \*S27H-1616 Special High Pressure Nipple for Hydraulic Hammer use.

<b>BSP/BSP</b>	<b>S26</b>	<b>S81</b>
----------------	------------	------------

**STRAIGHT**

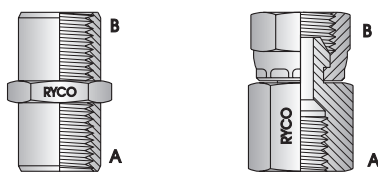

THREAD		DASH SIZE	BSPT FEMALE SOCKET	BSPT FEMALE FIXED BSPP FEMALE SWIVEL
A	B			
inch	inch		PART NO	PART NO
1/8	1/8	-0202	<b>S26-0202</b>	
1/4	1/4	-0404	<b>S26-0404</b>	<b>S81-0404</b>
3/8	1/4	-0604	<b>S26-0604</b>	
3/8	3/8	-0606	<b>S26-0606</b>	<b>S81-0606</b>
1/2	1/4	-0804	<b>S26-0804</b>	
1/2	3/8	-0806	<b>S26-0806</b>	<b>S81-0806</b>
1/2	1/2	-0808	<b>S26-0808</b>	<b>S81-0808</b>
3/4	1/4	-1204	<b>S26-1204</b>	
3/4	1/2	-1208	<b>S26-1208</b>	
3/4	3/4	-1212	<b>S26-1212</b>	<b>S81-1212</b>
1	3/4	-1612	<b>S26-1612</b>	
1	1	-1616	<b>S26-1616</b>	<b>S81-1616</b>
1.1/4	1.1/4	-2020	<b>S26-2020</b>	
1.1/2	1.1/2	-2424	<b>S26-2424</b>	
2	2	-3232	<b>S26-3232</b>	

<b>BSP/BSPP</b>	<b>S75</b>	<b>S44</b>
-----------------	------------	------------

**STRAIGHT  
SEAL SUPPLIED**

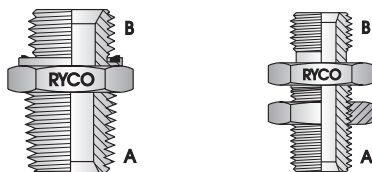

THREAD		DASH SIZE	BSPT MALE BSPP ENCAPSULATED MALE	BSPP MALE BULKHEAD BSPP MALE
A	B			
inch	inch		PART NO	PART NO
1/4	1/4	-0404	<b>S75-0404</b>	<b>S44-0404</b>
1/4	3/8	-0406	<b>S75-0406</b>	
1/4	1/2	-0408	<b>S75-0408</b>	
3/8	1/4	-0604	<b>S75-0604</b>	
3/8	3/8	-0606	<b>S75-0606</b>	<b>S44-0606</b>
3/8	1/2	-0608	<b>S75-0608</b>	
1/2	1/4	-0804	<b>S75-0804</b>	
1/2	3/8	-0806	<b>S75-0806</b>	
1/2	1/2	-0808	<b>S75-0808</b>	<b>S44-0808</b>
1/2	5/8	-0810	<b>S75-0810</b>	
1/2	3/4	-0812	<b>S75-0812</b>	
3/4	1/2	-1208	<b>S75-1208</b>	
3/4	3/4	-1212	<b>S75-1212</b>	<b>S44-1212</b>
3/4	1	-1216	<b>S75-1216</b>	
1	3/4	-1612	<b>S75-1612</b>	
1	1	-1616	<b>S75-1616</b>	<b>S44-1616</b>
1	1.1/4	-1620	<b>S75-1620</b>	
1.1/4	1.1/4	-2020	<b>S75-2020</b>	<b>S44-2020</b>
1.1/2	1.1/2	-2424	<b>S75-2424</b>	
2	2	-3232	<b>S75-3232</b>	

**NOTE:** S75 was previously O Ring & Retaining Ring design. Stock of previous design may exist and may be supplied.

INTRODUCTION

ADAPTORS

COUPLINGS

ADAPTORS

TECHNICAL



# ADAPTORS

## BSP ADAPTORS

BSP/BSPP	S46	S102	S43
----------	-----	------	-----

STRAIGHT  
SEAL SUPPLIED

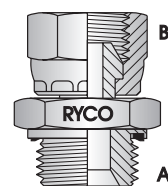
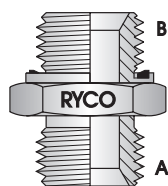

THREAD		DASH SIZE	BSPP MALE BSPP ENCAPSULATED MALE	BSPP ENCAPSULATED MALE BSPP FEMALE FIXED REDUCING BUSH	BSPP ENCAPSULATED MALE BSPP FEMALE SWIVEL
A	B				
inch	inch		PART NO	PART NO	PART NO
1/8	1/8	-0202			S43-0202
1/4	1/8	-0402		S102-0402	
1/4	1/4	-0404	S46-0404		S43-0404
1/4	3/8	-0406	S46-0406		
3/8	1/8	-0602		S102-0602	
3/8	1/4	-0604		S102-0604	
3/8	3/8	-0606	S46-0606		S43-0606
3/8	1/2	-0608	S46-0608		S43-0608
1/2	1/4	-0804	S46-0804	S102-0804	
1/2	3/8	-0806		S102-0806	S43-0806
1/2	1/2	-0808	S46-0808		S43-0808
1/2	3/4	-0812	S46-0812		
3/4	1/4	-1204		S102-1204	
3/4	3/8	-1206		S102-1206	
3/4	1/2	-1208		S102-1208	
3/4	3/4	-1212	S46-1212		S43-1212
3/4	1	-1216	S46-1216		
1	1/2	-1608		S102-1608	
1	3/4	-1612		S102-1612	
1	1	-1616	S46-1616		S43-1616
1.1/4	3/4	-2012		S102-2012	
1.1/4	1	-2016		S102-2016	
1.1/4	1.1/4	-2020	S46-2020		S43-2020
1.1/4	1.1/2	-2024	S46-2024		
1.1/2	1	-2416		S102-2416	
1.1/2	1.1/4	-2420		S102-2420	
1.1/2	1.1/2	-2424	S46-2424		
2	2	-3232	S46-3232		

NOTE: S43, S46 & S102 were previously O Ring & Retaining Ring design. Stock of previous design may exist and may be supplied.

<b>BSP/BSP</b>	<b>S45</b>	<b>S39</b>	<b>S84</b>	<b>S31</b>
----------------	------------	------------	------------	------------

### 45° ELBOW

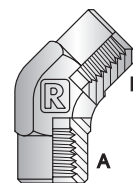
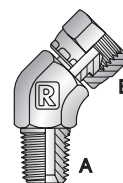
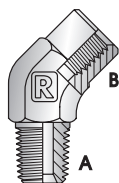
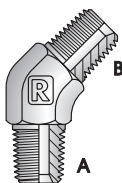

THREAD		DASH SIZE	BSPT MALE	BSPT MALE	BSPT MALE	BSPT FEMALE FIXED
A	B		BSPT MALE	BSPT FEMALE FIXED	BSPP FEMALE SWIVEL	BSPT FEMALE FIXED
			45° ELBOW	45° ELBOW	45° ELBOW	45° ELBOW
inch	inch		PART NO	PART NO	PART NO	PART NO
1/8	1/8	-0202				S31-0202
1/4	1/4	-0404	S45-0404	S39-0404	S84-0404	S31-0404
1/4	3/8	-0406		S39-0406		
3/8	3/8	-0606	S45-0606	S39-0606	S84-0606	S31-0606
1/2	3/8	-0806			S84-0806	
1/2	1/2	-0808	S45-0808	S39-0808	S84-0808	S31-0808
3/4	1/2	-1208	S45-1208			
3/4	3/4	-1212	S45-1212	S39-1212	S84-1212	S31-1212
1	1	-1616	S45-1616		S84-1616	S31-1616

<b>BSP/BSP</b>	<b>S49</b>	<b>S25</b>	<b>S82</b>	<b>S28</b>
----------------	------------	------------	------------	------------

### 90° ELBOW

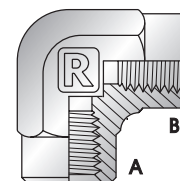
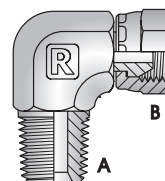
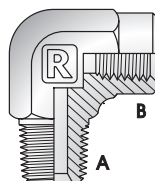
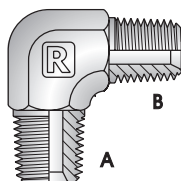

THREAD		DASH SIZE	BSPT MALE	BSPT MALE	BSPT MALE	BSPT FEMALE FIXED
A	B		BSPT MALE	BSPT FEMALE FIXED	BSPP FEMALE SWIVEL	BSPT FEMALE FIXED
			90° ELBOW	90° ELBOW	90° ELBOW	90° ELBOW
inch	inch		PART NO	PART NO	PART NO	PART NO
1/8	1/8	-0202	S49-0202	S25-0202	S82-0202	S28-0202
1/4	1/8	-0402	S49-0402			
1/4	1/4	-0404	S49-0404	S25-0404	S82-0404	S28-0404
3/8	1/4	-0604	S49-0604	S25-0604		
3/8	3/8	-0606	S49-0606	S25-0606	S82-0606	S28-0606
3/8	1/2	-0608		S25-0608		
1/2	1/4	-0804	S49-0804			
1/2	3/8	-0806	S49-0806	S25-0806	S82-0806	
1/2	1/2	-0808	S49-0808	S25-0808	S82-0808	S28-0808
1/2	3/4	-0812		S25-0812	S82-0812	
3/4	1/2	-1208	S49-1208			
3/4	3/4	-1212	S49-1212	S25-1212	S82-1212	S28-1212
3/4	1	-1216			S82-1216	
1	3/4	-1612	S49-1612		S82-1612	
1	1	-1616	S49-1616	S25-1616	S82-1616	S28-1616
1.1/4	3/4	-2012	S49-2012			
1.1/4	1	-2016	S49-2016			
1.1/4	1.1/4	-2020	S49-2020	S25-2020		S28-2020
1.1/2	1.1/2	-2424	S49-2424			

INTRODUCTION

ADAPTORS

COUPLINGS

ADAPTORS

TECHNICAL

# ADAPTORS

## BSP ADAPTORS

BSPP	35B	36B	RO-BP	RL21D
------	-----	-----	-------	-------

LOCK NUT  
RETAINING RING  
O RING  
&  
METAL BONDED SEAL  
WITH CENTRALISING LIP

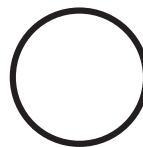
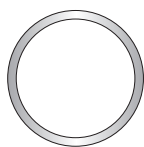

THREAD/ SEAL SIZE	DASH SIZE	BSPP LOCK NUT	BSPP RETAINING RING	BSPP O RING	BSPP METAL BONDED SEAL W/ CENTRALISING LIP	
inch		PART NO	PART NO	PART NO	PART NO	Pack Qty
1/8	-02	35B-02	36B-02	RO-BP02	RL21D-02	10
1/4	-04	35B-04	36B-04	RO-BP04	RL21D-04	10
3/8	-06	35B-06	36B-06	RO-BP06	RL21D-06	10
1/2	-08	35B-08	36B-08	RO-BP08	RL21D-08	10
5/8	-10		36B-10	RO-BP10	RL21D-10	10
3/4	-12	35B-12	36B-12	RO-BP12	RL21D-12	10
7/8	-14				RL21D-14	10
1	-16	35B-16	36B-16	RO-BP16	RL21D-16	5
1.1/4	-20	35B-20	36B-20	RO-BP20	RL21D-20	5
1.1/2	-24		36B-24	RO-BP24	RL21D-24	5
2	-32		36B-32	RO-BP32	RL21D-32	5

**NOTE:** O Rings are sold only in packs of 10. **Example:** Order Part No ROD-BPxx for pack of 10. (D is added after RO).

**NOTE for RL21D:** bonded seals are sold only in packs of 5 or 10. Part Number Series for individual seal is RL21. **Example:** Order Part No RL21-02 for individual seal. (D is removed from RL21D).

BSP/BSPP O RING	S77	S105
-----------------	-----	------

STRAIGHT  
90° ELBOW  
O RING & RETAINING  
RING SUPPLIED

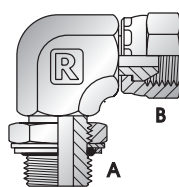
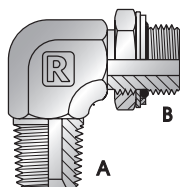

THREAD		DASH SIZE	BSPT MALE BSPP O RING MALE 90° ELBOW	BSPP O RING MALE BSPP FEMALE SWIVEL 90° ELBOW
A	B			
inch	inch		PART NO	PART NO
1/4	1/4	-0404	S77-0404	S105-0404
1/4	3/8	-0406	S77-0406	
3/8	3/8	-0606	S77-0606	S105-0606
3/8	1/2	-0608	S77-0608	
1/2	3/8	-0806		S105-0806
1/2	1/2	-0808	S77-0808	S105-0808
1/2	3/4	-0812	S77-0812	S105-0812
3/4	1/2	-1208		S105-1208
3/4	3/4	-1212	S77-1212	S105-1212
3/4	1	-1216	S77-1216	S105-1216
1	1	-1616	S77-1616	S105-1616
1.1/4	1.1/4	-2020		S105-2020

<b>BSP/BSP</b>	<b>S50</b>	<b>S48</b>	<b>S167</b>
----------------	------------	------------	-------------

TEE

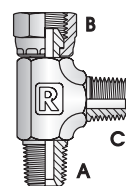
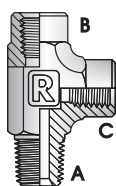
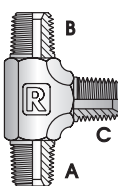

THREAD			DASH SIZE	BSPT MALE	BSPT MALE	BSPT MALE
A	B	C		BSPT MALE	BSPT FEMALE FIXED	BSPT FEMALE FIXED
inch	inch	inch		PART NO	PART NO	PART NO
1/8	1/8	1/8	-020202	S50-020202	S48-020202	
1/4	1/4	1/4	-040404	S50-040404	S48-040404	S167-040404
3/8	3/8	3/8	-060606	S50-060606	S48-060606	S167-060606
3/8	3/8	1/2	-060608	S50-060608		
1/2	1/2	1/2	-080808	S50-080808	S48-080808	S167-080808
1/2	1/2	3/4	-080812	S50-080812		
3/4	1/2	3/4	-120812	S50-120812		
3/4	3/4	1/2	-121208	S50-121208		
3/4	3/4	3/4	-121212	S50-121212	S48-121212	S167-121212
1	3/4	1	-161216	S50-161216		
1	1	1	-161616	S50-161616	S48-161616	S167-161616
1.1/4	1.1/4	1.1/4	-202020	S50-202020		

<b>BSP/BSP</b>	<b>S47</b>	<b>S83</b>
----------------	------------	------------

TEE

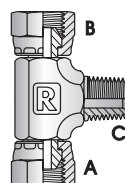
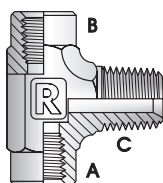

THREAD			DASH SIZE	BSPT FEMALE FIXED	BSPT FEMALE FIXED	BSPT MALE
A	B	C		BSPT FEMALE FIXED	BSPT FEMALE SWIVEL	BSPT MALE
inch	inch	inch		PART NO	PART NO	
1/4	1/4	1/4	-040404		S83-040404	
3/8	3/8	3/8	-060606		S83-060606	
1/2	1/2	1/2	-080808	S47-080808	S83-080808	
3/4	3/4	3/4	-121212	S47-121212	S83-121212	
1	1	1	-161616		S83-161616	

# ADAPTORS

## BSP ADAPTORS

<b>BSP/BSP</b>	<b>S29</b>	<b>S139</b>
----------------	------------	-------------

TEE

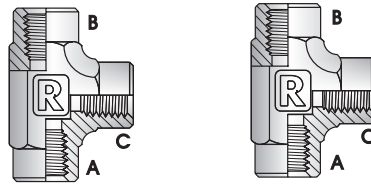

THREAD			DASH SIZE	BSPT FEMALE FIXED	BSPP FEMALE FIXED
A	B	C		BSPT FEMALE FIXED	BSPP FEMALE FIXED
inch	inch	inch		PART NO	PART NO
1/8	1/8	1/8	-020202	S29-020202	
1/4	1/4	1/4	-040404	S29-040404	S139-040404
3/8	3/8	3/8	-060606	S29-060606	
1/2	1/2	1/2	-080808	S29-080808	
3/4	3/4	3/4	-121212	S29-121212	
1	1	1	-161616	S29-161616	
1.1/4	1.1/4	1.1/4	-202020	S29-202020	
2	2	2	-323232	S29-323232	S139-323232

<b>BSP/BSP</b>	<b>S32</b>
----------------	------------

CROSS

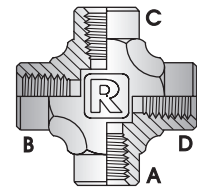

THREAD A, B, C, D	DASH SIZE	BSPT FEMALE FIXED CROSS
inch		PART NO
1/4	-04040404	S32-04040404
3/8	-06060606	S32-06060606
1/2	-08080808	S32-08080808
3/4	-12121212	S32-12121212
1	-16161616	S32-16161616

<b>BSP/BSPP O RING</b>	<b>S104</b>	<b>S135</b>
------------------------	-------------	-------------

TEE  
O RING & RETAINING RING SUPPLIED

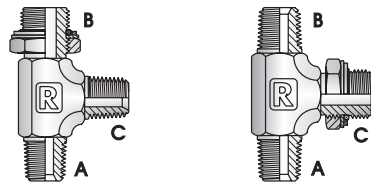

THREAD			DASH SIZE	BSPT MALE BSPP O RING MALE	BSPT MALE BSPP O RING MALE
A	B	C		BSPT MALE	BSPP O RING MALE
inch	inch	inch		PART NO	PART NO
1/4	1/4	1/4	-040404	S104-040404	
1/4	3/8	1/4	-040604	S104-040604	
3/8	3/8	3/8	-060606	S104-060606	S135-060606
1/2	1/2	1/2	-080808	S104-080808	
3/4	3/4	3/4	-121212	S104-121212	
1	1	1	-161616	S104-161616	
1.1/4	1.1/4	1.1/4	-202020	S104-202020	

<b>BSP/JIC</b>	<b>S130</b>	<b>S130P</b>
----------------	-------------	--------------

BULKHEAD

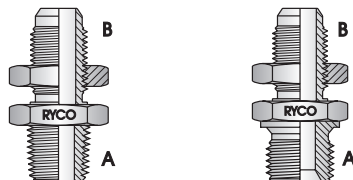

THREAD		DASH SIZE	BSPTM NO SEAT JICM BULKHEAD	BSPP MALE JICM BULKHEAD
A	B		BSPTM NO SEAT JICM BULKHEAD	BSPP MALE JICM BULKHEAD
inch	inch		PART NO	PART NO
3/8	9/16	-0609		S130P-0609
1/2	3/4	-0812	S130-0812	S130P-0812
1/2	7/8	-0814		S130P-0814

<b>BSP/JIC</b>	<b>S7</b>	<b>S128</b>	<b>S61</b>	<b>S16</b>
----------------	-----------	-------------	------------	------------

STRAIGHT

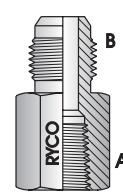
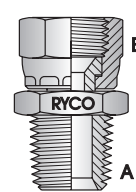
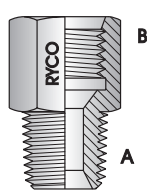
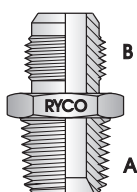

THREAD		DASH SIZE	BSPT MALE JIC MALE	BSPT MALE JIC/UN O RING FEMALE FIXED DUAL SEAT	BSPT MALE JIC FEMALE SWIVEL	BSPT FEMALE FIXED JIC MALE
A	B					
inch	inch		PART NO	PART NO	PART NO	PART NO
1/8	3/8	-0206	S7-0206			
1/8	7/16	-0207	S7-0207			S16-0207
1/8	1/2	-0208	S7-0208			
1/8	9/16	-0209	S7-0209			S16-0209
1/4	7/16	-0407	S7-0407		S61-0407	
1/4	1/2	-0408	S7-0408			
1/4	9/16	-0409	S7-0409		S61-0409	S16-0409
1/4	3/4	-0412	S7-0412			
1/4	7/8	-0414		S128-0414		
3/8	7/16	-0607	S7-0607			
3/8	1/2	-0608	S7-0608			
3/8	9/16	-0609	S7-0609		S61-0609	
3/8	3/4	-0612	S7-0612		S61-0612	S16-0612
3/8	7/8	-0614	S7-0614		S61-0614	
3/8	1.1/16	-0617	S7-0617			
1/2	7/16	-0807	S7-0807			
1/2	9/16	-0809	S7-0809			S16-0809
1/2	3/4	-0812	S7-0812	S128-0812	S61-0812	S16-0812
1/2	7/8	-0814	S7-0814	S128-0814	S61-0814	S16-0814
1/2	1.1/16	-0817	S7-0817			S16-0817
1/2	1.5/16	-0821	S7-0821			
5/8	3/4	-1012	S7-1012			
3/4	9/16	-1209	S7-1209			
3/4	3/4	-1212	S7-1212			
3/4	7/8	-1214	S7-1214			
3/4	1.1/16	-1217	S7-1217		S61-1217	S16-1217
3/4	1.3/16	-1219	S7-1219			
3/4	1.5/16	-1221	S7-1221			
1	7/8	-1614	S7-1614			
1	1.1/16	-1617	S7-1617			
1	1.3/16	-1619	S7-1619			
1	1.5/16	-1621	S7-1621		S61-1621	
1	1.5/8	-1626	S7-1626			
1.1/4	1.1/16	-2017	S7-2017			
1.1/4	1.5/16	-2021	S7-2021			
1.1/4	1.5/8	-2026	S7-2026			
1.1/2	1.5/16	-2421	S7-2421			
1.1/2	1.5/8	-2426	S7-2426		S61-2426	
1.1/2	1.7/8	-2430	S7-2430			
2	2.1/2	-3240	S7-3240			

INTRODUCTION

ADAPTORS

COUPLINGS

ADAPTORS

TECHNICAL

# ADAPTORS

## BSP ADAPTORS

BSP/JIC	S9	S8	S11
---------	----	----	-----

45° ELBOW  
90° ELBOW

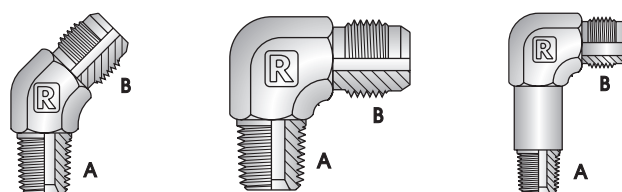

THREAD		DASH SIZE	BSPT MALE	BSPT MALE	BSPT MALE EXT
A	B		JIC MALE	JIC MALE	JIC MALE
			45° ELBOW	90° ELBOW	90° ELBOW
inch	inch		PART NO	PART NO	PART NO
1/8	7/16	-0207	S9-0207	S8-0207	S11-0207
1/8	1/2	-0208		S8-0208	
1/8	9/16	-0209		S8-0209	
1/4	7/16	-0407	S9-0407	S8-0407	
1/4	1/2	-0408	S9-0408	S8-0408	
1/4	9/16	-0409	S9-0409	S8-0409	
1/4	3/4	-0412	S9-0412	S8-0412	
3/8	7/16	-0607		S8-0607	
3/8	1/2	-0608		S8-0608	
3/8	9/16	-0609	S9-0609	S8-0609	
3/8	3/4	-0612	S9-0612	S8-0612	
3/8	7/8	-0614	S9-0614	S8-0614	
1/2	7/16	-0807		S8-0807	
1/2	9/16	-0809	S9-0809	S8-0809	
1/2	3/4	-0812	S9-0812	S8-0812	
1/2	7/8	-0814	S9-0814	S8-0814	S11-0814
1/2	1.1/16	-0817	S9-0817	S8-0817	
5/8	7/8	-1014		S8-1014	
3/4	9/16	-1209		S8-1209	
3/4	3/4	-1212		S8-1212	
3/4	7/8	-1214	S9-1214	S8-1214	
3/4	1.1/16	-1217	S9-1217	S8-1217	
3/4	1.3/16	-1219		S8-1219	
3/4	1.5/16	-1221	S9-1221	S8-1221	
1	1.1/16	-1617		S8-1617	
1	1.5/16	-1621	S9-1621	S8-1621	
1	1.5/8	-1626	S9-1626	S8-1626	
1.1/4	1.5/16	-2021		S8-2021	
1.1/4	1.5/8	-2026	S9-2026	S8-2026	
1.1/2	1.7/8	-2430	S9-2430	S8-2430	



<b>BSPP/JIC</b>	<b>S74</b>	<b>S71</b>
-----------------	------------	------------

**STRAIGHT  
SEAL SUPPLIED**

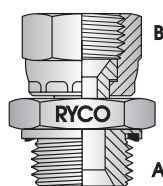
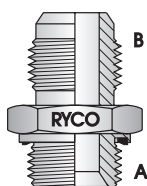

THREAD		DASH SIZE	BSPP ENCAPSULATED MALE JIC MALE	BSPP ENCAPSULATED MALE JIC FEMALE SWIVEL
A	B			
inch	inch		PART NO	PART NO
1/8	7/16	-0207	S74-0207	
1/8	9/16	-0209	S74-0209	
1/4	7/16	-0407	S74-0407	S71-0407
1/4	1/2	-0408	S74-0408	
1/4	9/16	-0409	S74-0409	S71-0409
1/4	3/4	-0412	S74-0412	
1/4	1.1/16	-0417	S74-0417	
3/8	7/16	-0607	S74-0607	
3/8	9/16	-0609	S74-0609	S71-0609
3/8	3/4	-0612	S74-0612	S71-0612
3/8	7/8	-0614	S74-0614	S71-0614
3/8	1.1/16	-0617	S74-0617	
1/2	7/16	-0807	S74-0807	
1/2	1/2	-0808		S71-0808
1/2	9/16	-0809	S74-0809	
1/2	3/4	-0812	S74-0812	S71-0812
1/2	7/8	-0814	S74-0814	S71-0814
1/2	1.1/16	-0817	S74-0817	
3/4	9/16	-1209	S74-1209	
3/4	3/4	-1212	S74-1212	
3/4	7/8	-1214	S74-1214	S71-1214
3/4	1.1/16	-1217	S74-1217	S71-1217
3/4	1.5/16	-1221	S74-1221	
3/4	1.5/8	-1226	S74-1226	
1	1.1/16	-1617	S74-1617	S71-1617
1	1.5/16	-1621	S74-1621	S71-1621
1	1.5/8	-1626	S74-1626	
1.1/4	1.1/16	-2017	S74-2017	
1.1/4	1.5/16	-2021	S74-2021	S71-2021
1.1/4	1.5/8	-2026	S74-2026	
1.1/2	1.1/16	-2417	S74-2417	
1.1/2	1.5/16	-2421	S74-2421	
1.1/2	1.5/8	-2426	S74-2426	
1.1/2	1.7/8	-2430	S74-2430	
2	1.5/16	-3221	S74-3221	

**NOTE:** S71 and S74 were previously O Ring & Retaining Ring design. Stock of previous design may exist and may be supplied.

INTRODUCTION

ADAPTORS

COUPLINGS

ADAPTORS

TECHNICAL

# ADAPTORS

## BSP ADAPTORS

BSP O RING/JIC	S69	S76	S70
----------------	-----	-----	-----

45° ELBOW  
90° ELBOW  
O RING & RETAINING  
RING SUPPLIED

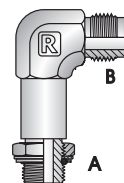
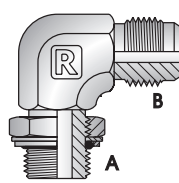
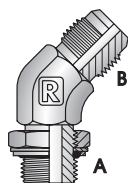

THREAD		DASH SIZE	BSP O RING MALE JIC MALE 45° ELBOW	BSP O RING MALE JIC MALE 90° ELBOW	BSP O RING MALE EXT JIC MALE 90° ELBOW
A	B				
inch	inch		PART NO	PART NO	PART NO
1/8	7/16	-0207		S76-0207	
1/8	9/16	-0209		S76-0209	
1/4	7/16	-0407		S76-0407	
1/4	1/2	-0408		S76-0408	
1/4	9/16	-0409	S69-0409	S76-0409	
1/4	3/4	-0412		S76-0412	
3/8	7/16	-0607		S76-0607	
3/8	9/16	-0609		S76-0609	S70-0609
3/8	3/4	-0612		S76-0612	S70-0612
3/8	7/8	-0614		S76-0614	
1/2	1/2	-0808		S76-0808	
1/2	9/16	-0809	S69-0809	S76-0809	
1/2	3/4	-0812	S69-0812	S76-0812	S70-0812
1/2	7/8	-0814	S69-0814	S76-0814	S70-0814
1/2	1.1/16	-0817		S76-0817	
3/4	9/16	-1209		S76-1209	
3/4	3/4	-1212		S76-1212	
3/4	7/8	-1214		S76-1214	
3/4	1.1/16	-1217		S76-1217	S70-1217
3/4	1.5/16	-1221		S76-1221	
1	1.1/16	-1617		S76-1617	
1	1.5/16	-1621	S69-1621	S76-1621	S70-1621
1.1/4	1.5/16	-2021		S76-2021	
1.1/4	1.5/8	-2026		S76-2026	

**BSP/JIC S21**

TEE

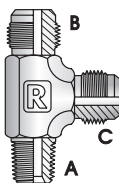

THREAD			DASH SIZE	BSPT MALE JIC MALE JIC MALE
A	B	C		
inch	inch	inch		PART NO
1/8	7/16	7/16	-020707	<b>S21-020707</b>
1/4	7/16	7/16	-040707	<b>S21-040707</b>
1/4	9/16	9/16	-040909	<b>S21-040909</b>
3/8	9/16	9/16	-060909	<b>S21-060909</b>
3/8	9/16	3/4	-060912	<b>S21-060912</b>
3/8	3/4	3/4	-061212	<b>S21-061212</b>
1/2	3/4	3/4	-081212	<b>S21-081212</b>
1/2	7/8	7/8	-081414	<b>S21-081414</b>
1/2	1.1/16	1.1/16	-081717	<b>S21-081717</b>
3/4	1.1/16	1.1/16	-121717	<b>S21-121717</b>
1	1.1/16	1.1/16	-161717	<b>S21-161717</b>
1	1.5/16	1.5/16	-162121	<b>S21-162121</b>

**BSPP O RING/JIC S78**

TEE  
O RING & RETAINING RING SUPPLIED

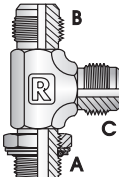

THREAD			DASH SIZE	BSPP O RING MALE JIC MALE JIC MALE
A	B	C		
inch	inch	inch		PART NO
1/4	7/16	7/16	-040707	<b>S78-040707</b>
1/4	9/16	9/16	-040909	<b>S78-040909</b>
1/4	3/4	3/4	-041212	<b>S78-041212</b>
3/8	9/16	9/16	-060909	<b>S78-060909</b>
3/8	3/4	3/4	-061212	<b>S78-061212</b>
1/2	3/4	3/4	-081212	<b>S78-081212</b>
1/2	7/8	7/8	-081414	<b>S78-081414</b>
1/2	1.1/16	1.1/16	-081717	<b>S78-081717</b>
3/4	3/4	3/4	-121212	<b>S78-121212</b>
3/4	1.1/16	1.1/16	-121717	<b>S78-121717</b>
1	1.5/16	1.5/16	-162121	<b>S78-162121</b>
1.1/4	1.1/16	1.1/16	-201717	<b>S78-201717</b>
1.1/4	1.5/8	1.5/8	-202626	<b>S78-202626</b>

**BSP/JIC S20**

TEE

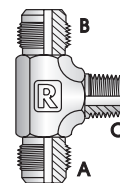

THREAD			DASH SIZE	JIC MALE JIC MALE BSPT MALE
A	B	C		
inch	inch	inch		PART NO
7/16	7/16	1/8	-070702	<b>S20-070702</b>
7/16	7/16	1/4	-070704	<b>S20-070704</b>
1/2	1/2	1/4	-080804	<b>S20-080804</b>
1/2	1/2	1/2	-080808	<b>S20-080808</b>
9/16	9/16	1/4	-090904	<b>S20-090904</b>
3/4	3/4	3/8	-121206	<b>S20-121206</b>
3/4	3/4	1/2	-121208	<b>S20-121208</b>
3/4	1.1/16	1/2	-121708	<b>S20-121708</b>
7/8	7/8	3/8	-141406	<b>S20-141406</b>
7/8	7/8	1/2	-141408	<b>S20-141408</b>
1.1/16	1.1/16	3/4	-171712	<b>S20-171712</b>
1.1/16	1.1/16	1	-171716	<b>S20-171716</b>
1.5/16	1.5/16	3/4	-212112	<b>S20-212112</b>
1.5/8	1.5/8	1.1/4	-262620	<b>S20-262620</b>

**BSPP O RING/JIC S79**

TEE  
O RING & RETAINING RING SUPPLIED

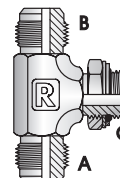

THREAD			DASH SIZE	JIC MALE JIC MALE BSPP O RING MALE
A	B	C		
inch	inch	inch		PART NO
7/16	7/16	1/4	-070704	<b>S79-070704</b>
9/16	9/16	1/4	-090904	<b>S79-090904</b>
9/16	9/16	3/8	-090906	<b>S79-090906</b>
3/4	3/4	3/8	-121206	<b>S79-121206</b>
3/4	3/4	1/2	-121208	<b>S79-121208</b>
7/8	7/8	1/2	-141408	<b>S79-141408</b>
7/8	7/8	3/4	-141412	<b>S79-141412</b>
1.1/16	1.1/16	3/4	-171712	<b>S79-171712</b>
1.5/16	1.5/16	3/4	-212112	<b>S79-212112</b>
1.5/16	1.5/16	1	-212116	<b>S79-212116</b>
1.5/8	1.5/8	1.1/4	-262620	<b>S79-262620</b>

INTRODUCTION

ADAPTORS

COUPLINGS

ADAPTORS

TECHNICAL

# ADAPTORS

## BSP ADAPTORS

<b>BSP/ORFS</b>	<b>S180</b>	<b>S181</b>
-----------------	-------------	-------------

**STRAIGHT  
SEAL SUPPLIED**

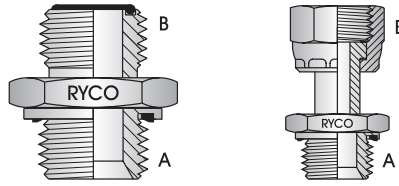

THREAD		DASH SIZE	BSP MALE ORFS MALE	BSP MALE ORFS FEMALE SWIVEL
A	B			
inch	inch		PART NO	PART NO
1/4	11/16	-0411	<b>S180-0411</b>	<b>S181-0411</b>
3/8	11/16	-0611	<b>S180-0611</b>	<b>S181-0611</b>
3/8	13/16	-0613	<b>S180-0613</b>	<b>S181-0613</b>
1/2	13/16	-0813	<b>S180-0813</b>	<b>S181-0813</b>
3/4	1.3/16	-1219	<b>S180-1219</b>	

**NOTE:** S180 and S181 were previously O Ring & Retaining Ring design. Stock of previous design may exist and may be supplied.

<b>BSP/SAE</b>	<b>SA7</b>	<b>SA9</b>	<b>SA8</b>
----------------	------------	------------	------------

**STRAIGHT  
45° ELBOW  
90° ELBOW**

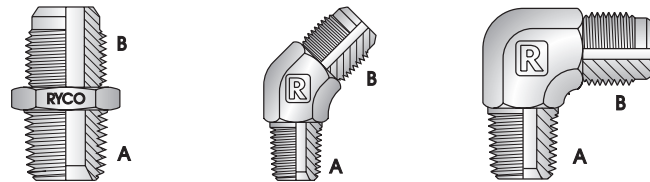

THREAD		DASH SIZE	BSPT MALE SAE MALE	BSPT MALE SAE MALE 45° ELBOW	BSPT MALE SAE MALE 90° ELBOW
A	B				
inch	inch		PART NO	PART NO	PART NO
1/8	3/8	-0206			<b>SA8-0206</b>
1/8	5/8	-0210			<b>SA8-0210</b>
1/4	5/8	-0410	<b>SA7-0410</b>	<b>SA9-0410</b>	<b>SA8-0410</b>
3/8	5/8	-0610	<b>SA7-0610</b>	<b>SA9-0610</b>	<b>SA8-0610</b>
3/4	1.1/16	-1217	<b>SA7-1217</b>		<b>SA8-1217</b>

<b>BSP/SAE</b>	<b>SA20</b>
----------------	-------------

**TEE**

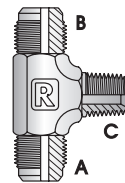

THREAD			DASH SIZE	SAE MALE SAE MALE BSPT MALE
A	B	C		
inch	inch	inch		PART NO
3/4	3/4	3/8	-121206	<b>SA20-121206</b>

<b>BSP/UNO</b>	<b>S93</b>	<b>S128</b>	<b>S85</b>	<b>S96</b>
----------------	------------	-------------	------------	------------

**STRAIGHT  
O RING SUPPLIED**

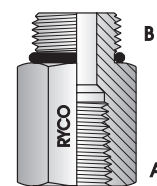
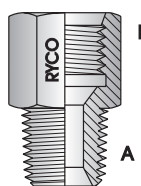
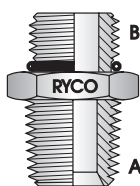

INTRODUCTION

THREAD		DASH SIZE	BSPT MALE UN O RING MALE	BSPT MALE JIC/UN O RING FEMALE FIXED DUAL SEAT	BSPT FEMALE FIXED UN O RING MALE REDUCING BUSH	BSPT FEMALE FIXED UN O RING MALE
A	B					
inch	inch		PART NO	PART NO	PART NO	PART NO
1/8	9/16	-0209			S85-0209	
1/8	3/4	-0212			S85-0212	
1/8	7/8	-0214			S85-0214	
1/4	9/16	-0409	S93-0409			S96-0409
1/4	3/4	-0412	S93-0412		S85-0412	
1/4	7/8	-0414	S93-0414	S128-0414	S85-0414	
1/4	1.1/16	-0417			S85-0417	
1/4	1.5/16	-0421			S85-0421	
3/8	9/16	-0609	S93-0609			
3/8	3/4	-0612	S93-0612			S96-0612
3/8	7/8	-0614	S93-0614		S85-0614	S96-0614
3/8	1.1/16	-0617	S93-0617		S85-0617	
3/8	1.5/16	-0621			S85-0621	
1/2	9/16	-0809	S93-0809			
1/2	3/4	-0812	S93-0812	S128-0812		S96-0812
1/2	7/8	-0814	S93-0814	S128-0814	S85-0814	S96-0814
1/2	1.1/16	-0817	S93-0817		S85-0817	
1/2	1.5/16	-0821			S85-0821	
1/2	1.5/8	-0826			S85-0826	
5/8	7/8	-1014	S93-1014			
5/8	1.1/16	-1017	S93-1017			
3/4	3/4	-1212	S93-1212			
3/4	7/8	-1214	S93-1214			
3/4	1.1/16	-1217	S93-1217			
3/4	1.5/16	-1221	S93-1221		S85-1221	
3/4	1.5/8	-1226			S85-1226	
1	1.1/16	-1617	S93-1617			
1	1.5/16	-1621	S93-1621			
1	1.5/8	-1626	S93-1626		S85-1626	
1.1/4	1.5/16	-2021	S93-2021			
1.1/4	1.5/8	-2026	S93-2026			
1.1/2	1.5/8	-2426	S93-2426			
1.1/2	1.7/8	-2430	S93-2430			

ADAPTORS

COUPLINGS

ADAPTORS

TECHNICAL

# ADAPTORS

## BSP ADAPTORS

BSP/UNO	S95	S60	S89	S94
---------	-----	-----	-----	-----

STRAIGHT  
45° ELBOW  
90° ELBOW  
O RING SUPPLIED

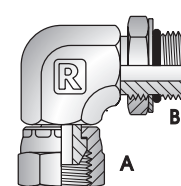
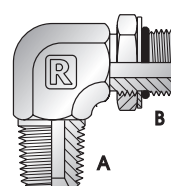
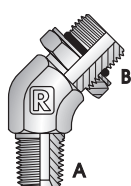
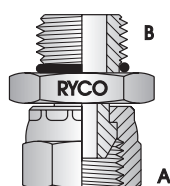

THREAD		DASH SIZE	BSPP FEMALE SWIVEL UN O RING MALE	BSPT MALE UN O RING MALE 45° ELBOW	BSPT MALE UN O RING MALE 90° ELBOW	BSPP FEMALE SWIVEL UN O RING MALE 90° ELBOW
A	B					
inch	inch		PART NO	PART NO	PART NO	PART NO
1/8	7/16	-0207				S94-0207
1/4	9/16	-0409	S95-0409	S60-0409	S89-0409	S94-0409
1/4	3/4	-0412			S89-0412	
1/4	7/8	-0414				
3/8	9/16	-0609			S89-0609	
3/8	3/4	-0612	S95-0612	S60-0612	S89-0612	S94-0612
3/8	7/8	-0614	S95-0614	S60-0614	S89-0614	
3/8	1.1/16	-0617				
1/2	3/4	-0812	S95-0812	S60-0812	S89-0812	S94-0812
1/2	7/8	-0814	S95-0814	S60-0814	S89-0814	S94-0814
1/2	1.1/16	-0817		S60-0817	S89-0817	
3/4	3/4	-1212			S89-1212	
3/4	7/8	-1214	S95-1214		S89-1214	
3/4	1.1/16	-1217	S95-1217	S60-1217	S89-1217	S94-1217
3/4	1.5/16	-1221				
1	1.5/16	-1621	S95-1621	S60-1621	S89-1621	S94-1621
1	1.5/8	-1626			S89-1626	
1.1/4	1.5/8	-2026			S89-2026	S94-2026

**NPT** **S64N**

**PLUG**

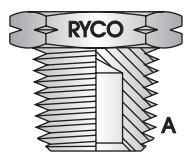

THREAD A	DASH SIZE	NPT MALE PLUG
inch		PART NO
1/8	-02	S64N-02
1/4	-04	S64N-04
3/8	-06	S64N-06
1/2	-08	S64N-08
3/4	-12	S64N-12
1	-16	S64N-16
1.1/4	-20	S64N-20
1.1/2	-24	S64N-24
2	-32	S64N-32

**NPT** **S53N**

**TUBE WELD**

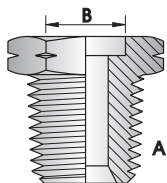

THREAD A	TUBE OD A	DASH SIZE	NPT MALE TUBE WELD
inch	inch		PART NO
3/8	1/2	-0608	S53N-0608
3/4	3/4	-1212	S53N-1212

**NPT/NPT** **S24N**

**REDUCING BUSH**

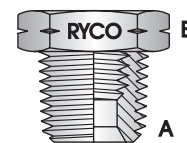

THREAD		DASH SIZE	NPT MALE NPT FEMALE FIXED REDUCING BUSH
A	B		
inch	inch		PART NO
1/4	1/8	-0402	S24N-0402
3/8	1/8	-0602	S24N-0602
3/8	1/4	-0604	S24N-0604
1/2	1/8	-0802	S24N-0802
1/2	1/4	-0804	S24N-0804
1/2	3/8	-0806	S24N-0806
3/4	1/8	-1202	S24N-1202
3/4	1/4	-1204	S24N-1204
3/4	3/8	-1206	S24N-1206
3/4	1/2	-1208	S24N-1208
1	3/8	-1606	S24N-1606
1	1/2	-1608	S24N-1608
1	3/4	-1612	S24N-1612
1.1/4	1/2	-2008	S24N-2008
1.1/4	3/4	-2012	S24N-2012
1.1/4	1	-2016	S24N-2016
1.1/2	1/2	-2408	S24N-2408
1.1/2	1	-2416	S24N-2416
1.1/2	1.1/4	-2420	S24N-2420
2	1.1/2	-3224	S24N-3224

INTRODUCTION

ADAPTORS

COUPLINGS

ADAPTORS

TECHNICAL



# ADAPTORS

## NPT ADAPTORS

NPT/NPT	S27N	S72N	S80N
---------	------	------	------

STRAIGHT

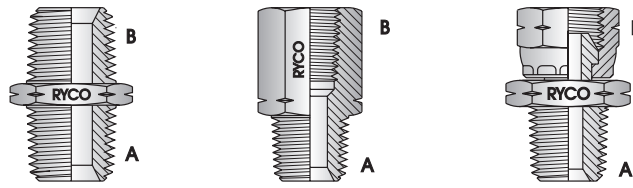

THREAD		DASH SIZE	NPT MALE	NPT MALE	NPT MALE
A	B		NPT MALE NIPPLE	NPT FEMALE FIXED	NPSM FEMALE SWIVEL
inch	inch		PART NO	PART NO	PART NO
1/8	1/8	-0202	S27N-0202	S72N-0202	S80N-0202
1/8	1/4	-0204		S72N-0204	
1/4	1/8	-0402	S27N-0402		
1/4	1/4	-0404	S27N-0404	S72N-0404	S80N-0404
1/4	3/8	-0406		S72N-0406	
3/8	1/4	-0604	S27N-0604		
3/8	3/8	-0606	S27N-0606	S72N-0606	S80N-0606
3/8	1/2	-0608		S72N-0608	S80N-0608
1/2	1/4	-0804	S27N-0804		
1/2	3/8	-0806	S27N-0806		
1/2	1/2	-0808	S27N-0808	S72N-0808	S80N-0808
1/2	3/4	-0812		S72N-0812	
3/4	1/2	-1208	S27N-1208		
3/4	3/4	-1212	S27N-1212	S72N-1212	S80N-1212
1	3/4	-1612	S27N-1612		
1	1	-1616	S27N-1616	S72N-1616	S80N-1616
1.1/4	1	-2016	S27N-2016		
1.1/4	1.1/4	-2020	S27N-2020		S80N-2020
1.1/2	3/4	-2412	S27N-2412		
1.1/2	1.1/2	-2424	S27N-2424		
2	1.1/2	-3224	S27N-3224		
2	2	-3232			S80N-3232

NPT/NPT	S26N	S81N
---------	------	------

STRAIGHT

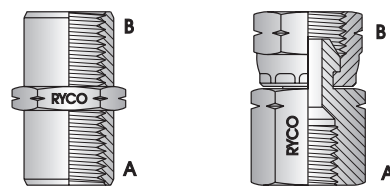

THREAD		DASH SIZE	NPT FEMALE	NPT FEMALE FIXED
A	B		SOCKET	NPSM FEMALE SWIVEL
inch	inch		PART NO	PART NO
1/8	1/8	-0202	S26N-0202	S81N-0202
1/4	1/4	-0404	S26N-0404	S81N-0404
3/8	3/8	-0606	S26N-0606	S81N-0606
1/2	1/2	-0808	S26N-0808	S81N-0808
3/4	3/4	-1212	S26N-1212	S81N-1212
1	1	-1616	S26N-1616	S81N-1616
1.1/4	1.1/4	-2020		S81N-2020
2	2	-3232	S26N-3232	

<b>NPT/NPT</b>	<b>S39N</b>	<b>S84N</b>	<b>S31N</b>
----------------	-------------	-------------	-------------

45° ELBOW

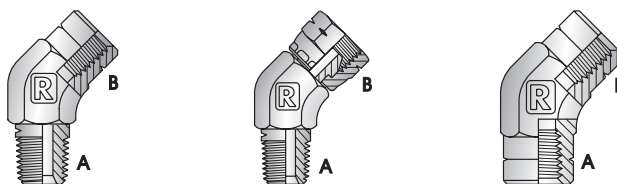

THREAD		DASH SIZE	NPT MALE NPT FEMALE FIXED 45° ELBOW	NPT MALE NPSM FEMALE SWIVEL 45° ELBOW	NPT FEMALE FIXED NPT FEMALE FIXED 45° ELBOW
A	B		PART NO	PART NO	PART NO
1/8	1/8	-0202	S39N-0202		S31N-0202
1/4	1/4	-0404	S39N-0404	S84N-0404	
3/8	3/8	-0606		S84N-0606	
1/2	3/8	-0806		S84N-0806	
1/2	1/2	-0808		S84N-0808	
1	1	-1616		S84N-1616	
1.1/4	1.1/4	-2020		S84N-2020	

<b>NPT/NPT</b>	<b>S49N</b>	<b>S25N</b>	<b>S82N</b>	<b>S28N</b>
----------------	-------------	-------------	-------------	-------------

90° ELBOW

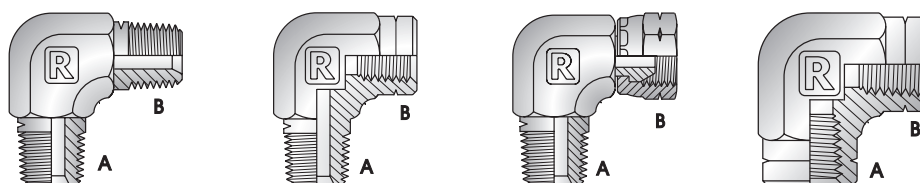

THREAD		DASH SIZE	NPT MALE NPT MALE 90° ELBOW	NPT MALE NPT FEMALE FIXED 90° ELBOW	NPT MALE NPSM FEMALE SWIVEL 90° ELBOW	NPT FEMALE FIXED NPT FEMALE FIXED 90° ELBOW
A	B		PART NO	PART NO	PART NO	PART NO
1/8	1/8	-0202	S49N-0202	S25N-0202		S28N-0202
1/4	1/4	-0404	S49N-0404	S25N-0404	S82N-0404	S28N-0404
3/8	1/4	-0604	S49N-0604			
3/8	3/8	-0606	S49N-0606	S25N-0606	S82N-0606	S28N-0606
1/2	1/2	-0808	S49N-0808	S25N-0808	S82N-0808	S28N-0808
3/4	3/4	-1212	S49N-1212	S25N-1212	S82N-1212	S28N-1212
1	1	-1616	S49N-1616	S25N-1616	S82N-1616	S28N-1616
1.1/4	1.1/4	-2020		S25N-2020	S82N-2020	

<b>NPT/NPT</b>	<b>S50N</b>	<b>S48N</b>	<b>S47N</b>	<b>S29N</b>	<b>S32N</b>
----------------	-------------	-------------	-------------	-------------	-------------

TEE CROSS

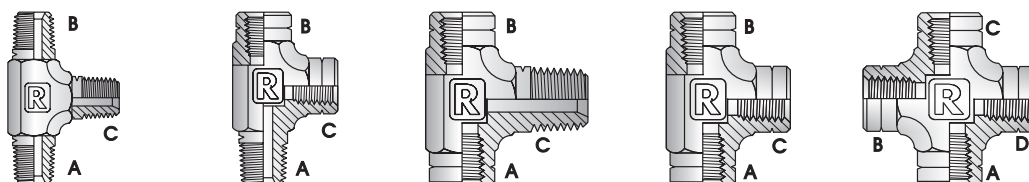

THREAD ALL ENDS	DASH SIZE	NPT MALE NPT MALE NPT MALE	NPT MALE NPT FEMALE FIXED NPT FEMALE FIXED	NPT FEMALE FIXED NPT FEMALE FIXED NPT MALE	NPT FEMALE FIXED NPT FEMALE FIXED NPT FEMALE FIXED	NPT FEMALE FIXED CROSS
inch		PART NO	PART NO	PART NO	PART NO	PART NO
1/8	-020202	S50N-020202	S48N-020202		S29N-020202	
1/4	-040404	S50N-040404	S48N-040404	S47N-040404	S29N-040404	S32N-04040404
3/8	-060606	S50N-060606	S48N-060606		S29N-060606	S32N-06060606
1/2	-080808	S50N-080808	S48N-080808		S29N-080808	S32N-08080808
3/4	-121212	S50N-080808	S48N-121212		S29N-121212	S32N-12121212
1	-161616		S48N-161616		S29N-161616	S32N-16161616
1.1/4	-202020				S29N-202020	
1.1/2	-242424				S29N-242424	

INTRODUCTION

ADAPTORS

COUPLINGS

ADAPTORS

TECHNICAL

# ADAPTORS

## NPT ADAPTORS

NPT/JIC	S7N	S16N	S61N
---------	-----	------	------

STRAIGHT

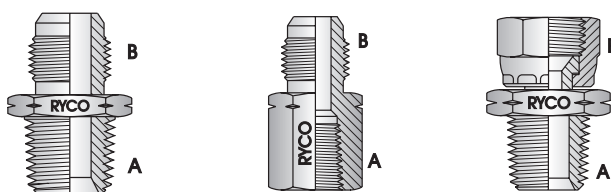

THREAD		DASH SIZE	NPT MALE JIC MALE	NPT FEMALE FIXED JIC MALE	NPT MALE JIC FEMALE SWIVEL
A	B				
inch	inch		PART NO	PART NO	PART NO
1/8	7/16	-0207	S7N-0207	S16N-0207	
1/8	1/2	-0208	S7N-0208		
1/8	9/16	-0209	S7N-0209		
1/4	7/16	-0407	S7N-0407	S16N-0407	S61N-0407
1/4	1/2	-0408	S7N-0408	S16N-0408	
1/4	9/16	-0409	S7N-0409	S16N-0409	S61N-0409
1/4	3/4	-0412	S7N-0412		
3/8	7/16	-0607	S7N-0607		
3/8	1/2	-0608	S7N-0608		
3/8	9/16	-0609	S7N-0609	S16N-0609	
3/8	3/4	-0612	S7N-0612		S61N-0612
3/8	7/8	-0614	S7N-0614		
3/8	1.1/16	-0617	S7N-0617		
1/2	7/8	-0807	S7N-0807		
1/2	9/16	-0809	S7N-0809		
1/2	3/4	-0812	S7N-0812	S16N-0812	S61N-0812
1/2	7/8	-0814	S7N-0814		
1/2	1.1/16	-0817	S7N-0817	S16N-0817	
3/4	9/16	-1209	S7N-1209		
3/4	3/4	-1212	S7N-1212		
3/4	7/8	-1214	S7N-1214		
3/4	1.1/16	-1217	S7N-1217	S16N-1217	
3/4	1.3/16	-1219	S7N-1219		
3/4	1.5/16	-1221	S7N-1221		
1	3/4	-1612	S7N-1612		
1	7/8	-1614	S7N-1614		
1	1.1/16	-1617	S7N-1617		
1	1.3/16	-1619	S7N-1619		
1	1.5/16	-1621	S7N-1621		
1	1.5/8	-1626	S7N-1626		
1.1/4	1.1/16	-2017	S7N-2017		
1.1/4	1.5/16	-2021	S7N-2021		
1.1/4	1.5/8	-2026	S7N-2026		
1.1/2	1.5/8	-2426	S7N-2426		
1.1/2	1.7/8	-2430	S7N-2430		
2	2.1/2	-3240	S7N-3240		

NPT/JIC	S9N	S8N	S11N
---------	-----	-----	------

45° ELBOW  
90° ELBOW

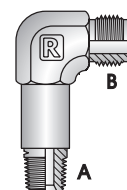
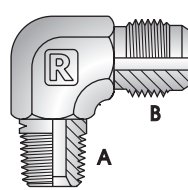
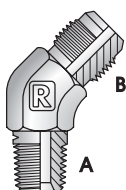

THREAD		DASH SIZE	NPT MALE JIC MALE 45° ELBOW	NPT MALE JIC MALE 90° ELBOW	NPT MALE EXT JIC MALE 90° ELBOW
A	B		PART NO	PART NO	PART NO
1/8	7/16	-0207	S9N-0207	S8N-0207	S11N-0207
1/8	1/2	-0208		S8N-0208	
1/8	9/16	-0209		S8N-0209	
1/4	7/16	-0407	S9N-0407	S8N-0407	
1/4	1/2	-0408	S9N-0408	S8N-0408	
1/4	9/16	-0409	S9N-0409	S8N-0409	
1/4	3/4	-0412	S9N-0412	S8N-0412	
3/8	7/16	-0607		S8N-0607	
3/8	1/2	-0608		S8N-0608	
3/8	9/16	-0609	S9N-0609	S8N-0609	
3/8	3/4	-0612	S9N-0612	S8N-0612	
3/8	7/8	-0614	S9N-0614	S8N-0614	
1/2	9/16	-0809	S9N-0809	S8N-0809	
1/2	3/4	-0812	S9N-0812	S8N-0812	
1/2	7/8	-0814	S9N-0814	S8N-0814	
1/2	1.1/16	-0817	S9N-0817	S8N-0817	
3/4	3/4	-1212		S8N-1212	
3/4	7/8	-1214	S9N-1214	S8N-1214	
3/4	1.1/16	-1217	S9N-1217	S8N-1217	
3/4	1.3/16	-1219		S8N-1219	
3/4	1.5/16	-1221	S9N-1221	S8N-1221	
1	1.1/16	-1617		S8N-1617	
1	1.5/16	-1621	S9N-1621	S8N-1621	
1	1.5/8	-1626		S8N-1626	
1.1/4	1.5/16	-2021		S8N-2021	
1.1/4	1.5/8	-2026	S9N-2026	S8N-2026	
1.1/2	1.7/8	-2430	S9N-2430	S8N-2430	
2	2.1/2	-3240	S9N-3240	S8N-3240	

INTRODUCTION

ADAPTORS

COUPLINGS

ADAPTORS

TECHNICAL

# ADAPTORS

## NPT ADAPTORS

<b>NPT/JIC</b>	<b>S21N</b>
----------------	-------------

TEE

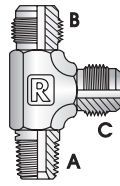

THREAD			DASH SIZE	NPT MALE JIC MALE JIC MALE	PART NO
A	B	C			
1/8	7/16	7/16	-020707		<b>S21N-020707</b>
1/4	7/16	7/16	-040707		<b>S21N-040707</b>
1/4	9/16	9/16	-040909		<b>S21N-040909</b>
3/8	9/16	9/16	-060909		<b>S21N-060909</b>
3/8	3/4	3/4	-061212		<b>S21N-061212</b>
1/2	3/4	3/4	-081212		<b>S21N-081212</b>
1/2	7/8	7/8	-081414		<b>S21N-081414</b>
3/4	1.1/16	1.1/16	-121717		<b>S21N-121717</b>

<b>NPT/JIC</b>	<b>S20N</b>
----------------	-------------

TEE

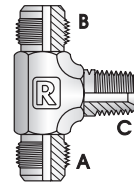

THREAD			DASH SIZE	JIC MALE JIC MALE NPT MALE	PART NO
A	B	C			
7/16	7/16	1/8	-070702		<b>S20N-070702</b>
7/16	7/16	1/4	-070704		<b>S20N-070704</b>
1/2	1/2	1/4	-080804		<b>S20N-080804</b>
9/16	9/16	1/4	-090904		<b>S20N-090904</b>
9/16	9/16	3/8	-090906		<b>S20N-090906</b>
3/4	3/4	3/8	-121206		<b>S20N-121206</b>
3/4	3/4	1/2	-121208		<b>S20N-121208</b>
7/8	7/8	1/2	-141408		<b>S20N-141408</b>
1.1/16	1.1/16	3/4	-171712		<b>S20N-171712</b>
1.5/16	1.5/16	1	-212116		<b>S20N-212116</b>

<b>NPT/ORFS</b>	<b>S114N</b>	<b>S145N</b>
-----------------	--------------	--------------

STRAIGHT  
90° ELBOW  
O RING INCLUDED

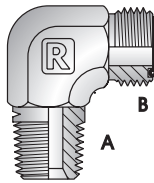
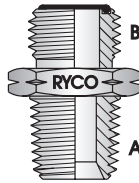

THREAD		DASH SIZE	NPT MALE ORFS MALE	NPT MALE ORFS MALE 90° ELBOW
A	B			
1/4	9/16	-0409	<b>S114N-0409</b>	<b>S145N-0409</b>
3/8	11/16	-0611	<b>S114N-0611</b>	<b>S145N-0611</b>
1/2	13/16	-0813	<b>S114N-0813</b>	<b>S145N-0813</b>
1/2	1	-0816	<b>S114N-0816</b>	<b>S145N-0816</b>
3/4	1.3/16	-1219	<b>S114N-1219</b>	<b>S145N-1219</b>
1	1.7/16	-1623	<b>S114N-1623</b>	<b>S145N-1623</b>

<b>NPT/SAE</b>	<b>SA7N</b>	<b>SA9N</b>	<b>SA8N</b>
----------------	-------------	-------------	-------------

STRAIGHT  
45° ELBOW  
90° ELBOW

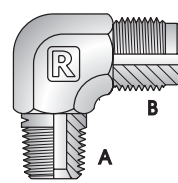
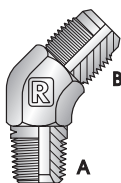
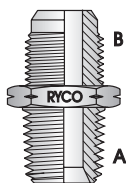

THREAD		DASH SIZE	NPT MALE	NPT MALE	NPT MALE
A	B		SAE MALE	SAE MALE	SAE MALE
inch	inch		PART NO	PART NO	PART NO
1/8	1/2	-0208	SA7N-0208		
1/8	5/8	-0210	SA7N-0210		SA8N-0210
1/4	7/16	-0407	SA7N-0407		SA8N-0407
1/4	1/2	-0408	SA7N-0408		SA8N-0408
1/4	5/8	-0410	SA7N-0410	SA9N-0410	SA8N-0410
3/8	1/2	-0608	SA7N-0608		
3/8	5/8	-0610	SA7N-0610		SA8N-0610
1/2	3/4	-0812	SA7N-0812		
3/4	1.1/16	-1217	SA7N-1217		SA8N-1217

<b>NPT/SAE</b>	<b>SA20N</b>	<b>NPT/UNO</b>	<b>S96N</b>
----------------	--------------	----------------	-------------

TEE

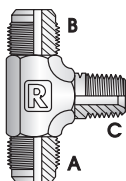

STRAIGHT  
O RING SUPPLIED

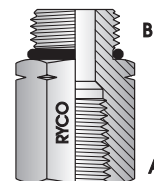

THREAD			DASH SIZE	SAE MALE
A	B	C		NPT MALE
inch	inch	inch		PART NO
7/16	7/16	1/4	-070704	SA20N-070704
1/2	1/2	1/4	-080804	SA20N-080804

THREAD		DASH SIZE	NPT FEMALE FIXED
A	B		UN O RING MALE
inch	inch		PART NO
1/2	3/4	-0812	S96N-0812
3/4	1.5/16	-1221	S96N-1221

<b>NPSM/UNO</b>	<b>S95N</b>	<b>S94N</b>
-----------------	-------------	-------------

STRAIGHT  
90° ELBOW  
O RING SUPPLIED

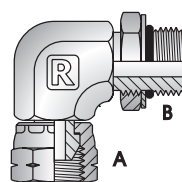
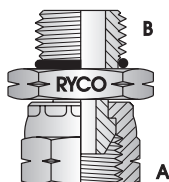

THREAD		DASH SIZE	NPSM FEMALE SWIVEL	NPSM FEMALE
A	B		UN O RING MALE	UN O RING MALE
inch	inch		PART NO	PART NO
1/4	9/16	-0409		S94N-0409
1/2	3/4	-0812	S95N-0812	

# ADAPTORS

## JIC ADAPTORS

JIC	S56	S65	S65S
-----	-----	-----	------

PLUG  
CAP

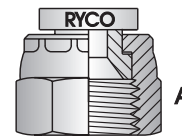
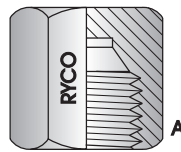
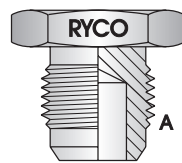

THREAD A	DASH SIZE	JIC MALE PLUG	JIC FEMALE CAP	JIC FEMALE SWIVEL CAP
inch		PART NO	PART NO	PART NO
7/16	-07	S56-07	S65-07	S65S-07
1/2	-08	S56-08	S65-08	S65S-08
9/16	-09	S56-09	S65-09	S65S-09
3/4	-12	S56-12	S65-12	S65S-12
7/8	-14	S56-14	S65-14	S65S-14
1.1/16	-17	S56-17	S65-17	S65S-17
1.3/16	-19	S56-19	S65-19	S65S-19
1.5/16	-21	S56-21	S65-21	S65S-21
1.5/8	-26	S56-26	S65-26	S65S-26
1.7/8	-30	S56-30	S65-30	S65S-30
2.1/2	-40	S56-40	S65-40	S65S-40

JIC	S51	S52	S57	S152
-----	-----	-----	-----	------

TUBE WELD  
90° TUBE WELD  
TEE TUBE WELD

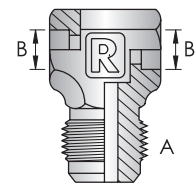
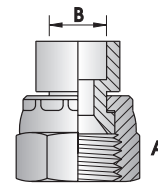
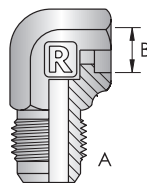
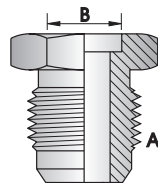

THREAD A	TUBE OD B	DASH SIZE	JIC MALE TUBE WELD	JIC MALE TUBE WELD 90° ELBOW	JIC FEMALE SWIVEL TUBE WELD	JIC MALE TUBE WELD TEE
inch	inch		PART NO	PART NO	PART NO	PART NO
7/16	1/4	-0704	S51-0704	S52-0704	S57-0704	
7/16	3/8	-0706	S51-0706		S57-0706	
9/16	3/8	-0906	S51-0906	S52-0906	S57-0906	
9/16	1/2	-0908	S51-0908			
3/4	3/8	-1206		S52-1206		
3/4	1/2	-1208	S51-1208	S52-1208	S57-1208	S152-120808
3/4	5/8	-1210	S51-1210		S57-1210	
3/4	3/4	-1212	S51-1212			S152-121212
7/8	5/8	-1410	S51-1410	S52-1410	S57-1410	S152-141010
7/8	3/4	-1412	S51-1412	S52-1412	S57-1412	
1.1/16	5/8	-1710	S51-1710			
1.1/16	3/4	-1712	S51-1712	S52-1712	S57-1712	
1.1/16	7/8	-1714	S51-1714			
1.1/16	1	-1716	S51-1716		S57-1716	S152-171616
1.3/16	7/8	-1914	S51-1914	S52-1914		
1.5/16	1	-2116	S51-2116	S52-2116	S57-2116	
1.5/16	1.1/8	-2118	S51-2118			
1.5/16	1.1/4	-2120	S51-2120		S57-2120	S152-212020
1.5/8	1.1/4	-2620	S51-2620	S52-2620	S57-2620	
1.5/8	1.3/8	-2622	S51-2622			
1.5/8	1.1/2	-2624	S51-2624		S57-2624	
1.7/8	1.1/2	-3024	S51-3024		S57-3024	
2.1/2	2	-4032	S51-4032		S57-4032	



**JIC S6**

**TUBE NUT & SLEEVE (FLARE TYPE)**

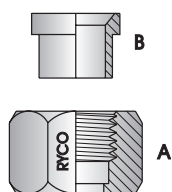

THREAD A	TUBE OD B	DASH SIZE	JIC FEMALE NUT & SLEEVE
inch	inch		PART NO
7/16	1/4	-0704	<b>S6-0704</b>
1/2	5/16	-0805	<b>S6-0805</b>
9/16	3/8	-0906	<b>S6-0906</b>
3/4	1/2	-1208	<b>S6-1208</b>
7/8	5/8	-1410	<b>S6-1410</b>
1.1/16	3/4	-1712	<b>S6-1712</b>
1.3/16	7/8	-1914	<b>S6-1914</b>
1.5/16	1	-2116	<b>S6-2116</b>
1.5/8	1.1/4	-2620	<b>S6-2620</b>

**JIC S6M**

**TUBE NUT & METRIC SLEEVE (FLARE TYPE)**

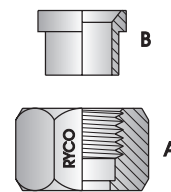

THREAD A	TUBE OD B	DASH SIZE	JIC FEMALE NUT & METRIC SLEEVE
inch	mm		PART NO
7/16	6	-0706	<b>S6M-0706</b>
1/2	8	-0808	<b>S6M-0808</b>
9/16	10	-0910	<b>S6M-0910</b>
3/4	12	-1212	<b>S6M-1212</b>
7/8	16	-1416	<b>S6M-1416</b>
1.1/16	19	-1719	<b>S6M-1719</b>
1.3/16	20	-1920	<b>S6M-1920</b>
1.5/16	25	-2125	<b>S6M-2125</b>
1.5/8	32	-2632	<b>S6M-2632</b>

**JIC S6S**

**TUBE NUT & SHORT SLEEVE (FLARE TYPE)**

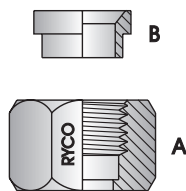

THREAD A	TUBE OD B	DASH SIZE	JIC FEMALE NUT & SHORT SLEEVE
inch	inch		PART NO
9/16	3/8	-0906	<b>S6S-0906</b>
3/4	1/2	-1208	<b>S6S-1208</b>
7/8	5/8	-1410	<b>S6S-1410</b>

**J-LOK S134**

**JIC FEMALE NUT & FLARELESS OLIVE**

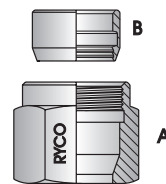

THREAD A	TUBE OD B	DASH SIZE	J-LOK NUT & OLIVE
inch	inch		PART NO
7/16	1/4	-0704	<b>S134-0704</b>
9/16	3/8	-0906	<b>S134-0906</b>
3/4	1/2	-1208	<b>S134-1208</b>
7/8	5/8	-1410	<b>S134-1410</b>
1.1/16	3/4	-1712	<b>S134-1712</b>
1.5/16	1	-2116	<b>S134-2116</b>

**NOTE:** S134 Assembly Instructions page 488.

INTRODUCTION

ADAPTORS

COUPLINGS

ADAPTORS

TECHNICAL

# ADAPTORS

## JIC ADAPTORS

JIC/JIC	S10	S17	S66F	S66	S23
---------	-----	-----	------	-----	-----

STRAIGHT  
BULKHEAD  
45° ELBOW

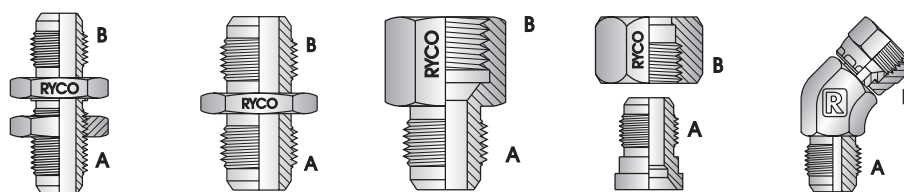

THREAD		DASH SIZE	JIC MALE BULKHEAD	JIC MALE	JIC MALE	JIC MALE	JIC MALE
A	B		JIC MALE	JIC MALE	JIC FEMALE FIXED REDUCER	JIC FEMALE REDUCER	JIC FEMALE SWIVEL 45° ELBOW
inch	inch		PART NO	PART NO	PART NO	PART NO	PART NO
7/16	7/16	-0707	S10-0707	S17-0707			S23-0707
7/16	9/16	-0709			S66F-0709	S66-0709	
7/16	3/4	-0712			S66F-0712	S66-0712	
7/16	7/8	-0714			S66F-0714	S66-0714	
7/16	1.1/16	-0717			S66F-0717	S66-0717	
7/16	1.5/16	-0721			S66F-0721	S66-0721	
1/2	1/2	-0808		S17-0808			S23-0808
9/16	7/16	-0907		S17-0907	S66F-0907		
9/16	9/16	-0909	S10-0909	S17-0909			S23-0909
9/16	3/4	-0912			S66F-0912	S66-0912	
9/16	7/8	-0914			S66F-0914	S66-0914	
9/16	1.1/16	-0917			S66F-0917	S66-0917	
9/16	1.5/16	-0921			S66F-0921	S66-0921	
9/16	1.5/8	-0926			S66F-0926		
3/4	9/16	-1209		S17-1209	S66F-1209	S66-1209*	
3/4	7/16	-1207			S66F-1207		
3/4	3/4	-1212	S10-1212	S17-1212			S23-1212
3/4	7/8	-1214			S66F-1214	S66-1214	
3/4	1.1/16	-1217			S66F-1217	S66-1217	
3/4	1.5/16	-1221			S66F-1221	S66-1221	
3/4	1.5/8	-1226			S66F-1226		
3/4	1.7/8	-1230			S66F-1230		
7/8	3/4	-1412		S17-1412	S66F-1412	S66-1412*	
7/8	7/8	-1414	S10-1414	S17-1414			S23-1414
7/8	1.1/16	-1417			S66F-1417	S66-1417	
1.1/16	7/16	-1707		S17-1707			
1.1/16	1/2	-1708		S17-1708			
1.1/16	9/16	-1709		S17-1709	S66F-1709		
1.1/16	3/4	-1712		S17-1712	S66F-1712		
1.1/16	7/8	-1714	S10-1714	S17-1714	S66F-1714	S66-1714	
1.1/16	1.1/16	-1717	S10-1717	S17-1717			S23-1717
1.1/16	1.5/16	-1721			S66F-1721	S66-1721	
1.1/16	1.5/8	-1726			S66F-1726		
1.3/16	1.3/16	-1919	S10-1919	S17-1919			
1.5/16	3/4	-2112			S66F-2112	S66-2112	
1.5/16	7/8	-2114		S17-2114			
1.5/16	1.1/16	-2117		S17-2117	S66F-2117	S66-2117	
1.5/16	1.5/16	-2121	S10-2121	S17-2121			S23-2121
1.5/16	1.5/8	-2126			S66F-2126	S66-2126	
1.5/16	1.7/8	-2130			S66F-2130		
1.5/8	1.5/16	-2621		S17-2621	S66F-2621	S66-2621	
1.5/8	1.5/8	-2626	S10-2626	S17-2626			S23-2626
1.7/8	1.7/8	-3030	S10-3030	S17-3030			S23-3030
2.1/2	1.5/16	-4021			S66F-4021		
2.1/2	2.1/2	-4040	S10-4040	S17-4040			

NOTE: \*These Sizes are One Piece Construction - see S66F range.

INTRODUCTION

ADAPTORS

COUPLINGS

ADAPTORS

TECHNICAL

JIC/JIC	S18	S13	S15
---------	-----	-----	-----

90° ELBOW

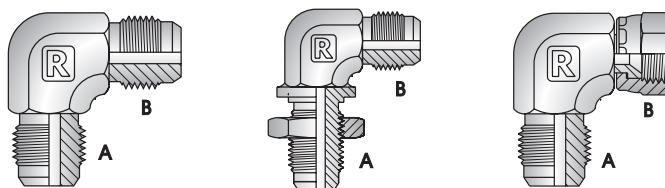

THREAD		DASH SIZE	JIC MALE	JIC MALE BULKHEAD	JIC MALE
A	B		JIC MALE 90° ELBOW	JIC MALE 90° ELBOW	JIC FEMALE SWIVEL 90° ELBOW
inch	inch		PART NO	PART NO	PART NO
7/16	7/16	-0707	S18-0707	S13-0707	S15-0707
1/2	1/2	-0808	S18-0808	S13-0808	S15-0808
9/16	9/16	-0909	S18-0909	S13-0909	S15-0909
3/4	9/16	-1209	S18-1209		
3/4	3/4	-1212	S18-1212	S13-1212	S15-1212
7/8	3/4	-1412	S18-1412		S15-1412
7/8	7/8	-1414	S18-1414	S13-1414	S15-1414
7/8	1.1/16	-1417			S15-1417
1.1/16	7/8	-1714	S18-1714		S15-1714
1.1/16	1.1/16	-1717	S18-1717	S13-1717	S15-1717
1.3/16	1.3/16	-1919	S18-1919		S15-1919
1.5/16	1.1/16	-2117	S18-2117		
1.5/16	1.5/16	-2121	S18-2121	S13-2121	S15-2121
1.5/8	1.5/8	-2626	S18-2626	S13-2626	S15-2626
1.7/8	1.7/8	-3030			S15-3030

JIC/JIC	S5	S4	S103
---------	----	----	------

45° BEND  
90° BEND

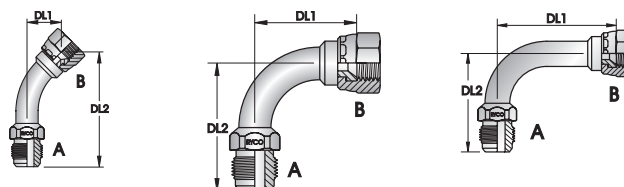

THREAD		DASH SIZE	JIC MALE JIC FEMALE SWIVEL 45° TUBE BEND			JIC MALE JIC FEMALE SWIVEL 90° TUBE BEND			JIC MALE JIC FEMALE SWIVEL 90° LONG BEND		
A	B		PART NO	DL1	DL2	PART NO	DL1	DL2	PART NO	DL1	DL2
inch	inch		PART NO	DL1	DL2	PART NO	DL1	DL2	PART NO	DL1	DL2
7/16	7/16	-0707				S4-0707	22	38	S103-0707	47	38
9/16	9/16	-0909	S5-0909	16	54	S4-0909	27	43	S103-0909	55	44
3/4	3/4	-1212	S5-1212	22	64	S4-1212	38	60	S103-1212	62	60
7/8	7/8	-1414	S5-1414	24	72	S4-1414	48	66	S103-1414	70	66
1.1/16	1.1/16	-1717	S5-1717	30	90	S4-1717	57	78	S103-1717	96	78
1.5/16	1.5/16	-2121	S5-2121	33	102	S4-2121	73	92	S103-2121	114	94
1.5/8	1.5/8	-2626	S5-2626	46	121	S4-2626	82	108	S103-2626	140	108
1.7/8	1.7/8	-3030				S4-3030	104	130			
2.1/2	2.1/2	-4040				S4-4040	140	164	S103-4040	222	164

NOTE: Drop Lengths (DL) dimensions are in millimetres.

# ADAPTORS

## JIC ADAPTORS

JIC/JIC	S19	S62	S63
---------	-----	-----	-----

TEE

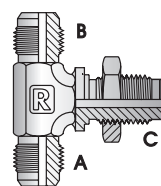
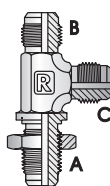
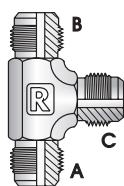

THREAD			DASH SIZE	JIC MALE	JIC MALE BULKHEAD	JIC MALE
A	B	C		JIC MALE	JIC MALE	JIC MALE BULKHEAD
inch	inch	inch		PART NO	PART NO	PART NO
7/16	7/16	7/16	-070707	S19-070707	S62-070707	S63-070707
1/2	1/2	1/2	-080808	S19-080808	S62-080808	S63-080808
9/16	9/16	9/16	-090909	S19-090909	S62-090909	S63-090909
9/16	9/16	3/4	-090912		S62-090912	
3/4	1/2	3/4	-120812	S19-120812		
3/4	3/4	9/16	-121209	S19-121209		
3/4	3/4	3/4	-121212	S19-121212	S62-121212	S63-121212
3/4	3/4	7/8	-121214	S19-121214	S62-121214	
3/4	3/4	1.1/16	-121217	S19-121217		
7/8	3/4	7/8	-141214	S19-141214		
7/8	7/8	3/4	-141412	S19-141412		
7/8	7/8	7/8	-141414	S19-141414	S62-141414	S63-141414
7/8	7/8	1.1/16	-141417	S19-141417	S62-141417	
1.1/16	3/4	3/4	-171212	S19-171212		
1.1/16	7/8	7/8	-171414	S19-171414		
1.1/16	1.1/16	7/8	-171714	S19-171714		
1.1/16	1.1/16	1.1/16	-171717	S19-171717	S62-171717	S63-171717
1.1/16	1.1/16	1.5/16	-171721	S19-171721		
1.1/16	1.1/16	1.5/8	-171726	S19-171726		
1.3/16	1.3/16	1.3/16	-191919	S19-191919		
1.5/16	7/8	7/8	-211414	S19-211414		
1.5/16	1.1/16	1.1/16	-211717	S19-211717		
1.5/16	1.5/16	7/8	-212114	S19-212114		
1.5/16	1.5/16	1.1/16	-212117	S19-212117		
1.5/16	1.5/16	1.5/16	-212121	S19-212121	S62-212121	S63-212121
1.5/8	1.5/8	1.5/8	-262626	S19-262626	S62-262626	S63-262626

<b>JIC/JIC</b>	<b>S68</b>	<b>S67</b>
----------------	------------	------------

**TEE**

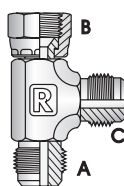
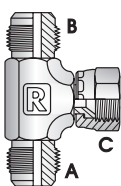

THREAD			DASH SIZE	JIC MALE	JIC MALE
A	B	C		JIC MALE	JIC FEMALE SWIVEL
inch	inch	inch		PART NO	PART NO
7/16	7/16	7/16	-070707	<b>S68-070707</b>	<b>S67-070707</b>
1/2	1/2	1/2	-080808	<b>S68-080808</b>	<b>S67-080808</b>
9/16	9/16	9/16	-090909	<b>S68-090909</b>	<b>S67-090909</b>
9/16	3/4	9/16	-091209		<b>S67-091209</b>
3/4	3/4	9/16	-121209		<b>S67-121209</b>
3/4	3/4	3/4	-121212	<b>S68-121212</b>	<b>S67-121212</b>
7/8	7/8	9/16	-141409		<b>S67-141409</b>
7/8	7/8	3/4	-141412		<b>S67-141412</b>
7/8	7/8	7/8	-141414	<b>S68-141414</b>	<b>S67-141414</b>
7/8	7/8	1.1/16	-141417		<b>S67-141417</b>
7/8	1.1/16	7/8	-141714		<b>S67-141714</b>
1.1/16	1.1/16	7/8	-171714	<b>S68-171714</b>	<b>S67-171714</b>
1.1/16	1.1/16	1.1/16	-171717	<b>S68-171717</b>	<b>S67-171717</b>
1.1/16	1.5/16	1.1/16	-172117		<b>S67-172117</b>
1.5/16	1.5/16	7/8	-212114		<b>S67-212114</b>
1.5/16	1.5/16	1.1/16	-212117	<b>S68-212117</b>	<b>S67-212117</b>
1.5/16	1.5/16	1.5/16	-212121	<b>S68-212121</b>	<b>S67-212121</b>
1.5/8	1.5/8	1.5/8	-262626	<b>S68-262626</b>	<b>S67-262626</b>
1.7/8	1.7/8	1.7/8	-303030	<b>S68-303030</b>	<b>S67-303030</b>

<b>JIC</b>	<b>S100</b>	<b>JIC LOCK NUT</b>	<b>35/37</b>
------------	-------------	---------------------	--------------

**CROSS**

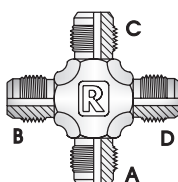

**LOCK NUT**



THREAD A, B, C, D	DASH SIZE	JIC MALE CROSS
inch		PART NO
9/16	-09090909	<b>S100-09090909</b>
3/4	-12121212	<b>S100-12121212</b>
7/8	-14141414	<b>S100-14141414</b>
1.1/16	-17171717	<b>S100-17171717</b>
1.5/16	-21212121	<b>S100-21212121</b>

THREAD	DASH SIZE	JIC LOCK NUT
inch		PART NO
7/16	-07	<b>37-07</b>
1/2	-08	<b>37-08</b>
9/16	-09	<b>37-09</b>
3/4	-12	<b>37-12</b>
7/8	-14	<b>37-14</b>
1.1/16	-17	<b>37-17</b>
1.3/16	-19	<b>37-19</b>
1.5/16	-21	<b>37-21</b>
1.5/8	-26	<b>35-26</b>

**NOTE:** 37- is JIC B/H Lock Nut, 35- is UNO Adj. Male Nut (-26 size is common for both).

INTRODUCTION

ADAPTORS

COUPLINGS

ADAPTORS

TECHNICAL

# ADAPTORS

## JIC ADAPTORS

JIC/ORFS	S108	S109	S110
----------	------	------	------

STRAIGHT  
O RING INCLUDED

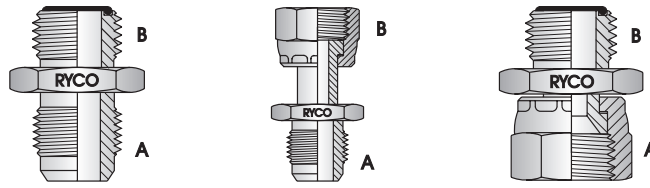

THREAD		DASH SIZE	JIC MALE ORFS MALE	JIC MALE ORFS FEMALE SWIVEL	JIC FEMALE SWIVEL ORFS MALE
A	B		PART NO	PART NO	PART NO
7/16	9/16	-0709	S108-0709	S109-0709	S110-0709
9/16	11/16	-0911	S108-0911	S109-0911	S110-0911
3/4	13/16	-1213	S108-1213	S109-1213	S110-1213
7/8	13/16	-1413	S108-1413		S110-1413
7/8	1	-1416	S108-1416	S109-1416	S110-1416
1.1/16	1.3/16	-1719	S108-1719	S109-1719	S110-1719
1.5/16	1.7/16	-2123	S108-2123	S109-2123	S110-2123

JIC/ORFS	S138	S137
----------	------	------

45° TUBE BEND  
90° TUBE BEND

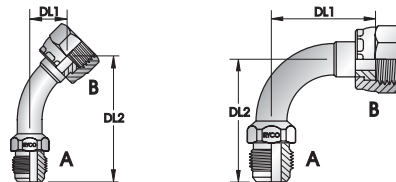

THREAD		DASH SIZE	JIC MALE ORFS FEMALE SWIVEL 45° TUBE BEND			JIC MALE ORFS FEMALE SWIVEL 90° TUBE BEND		
A	B		PART NO	DL1	DL2	PART NO	DL1	DL2
7/16	9/16	-0709	S138-0709	21	42	S137-0709	32	39
9/16	11/16	-0911	S138-0911	28	62	S137-0911	38	46
3/4	13/16	-1213	S138-1213	20	62	S137-1213	40	56
7/8	1	-1416	S138-1416	23	77	S137-1416	47	65
7/8	1.3/16	-1419				S137-1419	49	65
1.1/16	1.3/16	-1719	S138-1719	27	87	S137-1719	59	81
1.5/16	1.7/16	-2123	S138-2123	45	104	S137-2123	71	89

NOTE: Drop Lengths (DL) dimensions are in millimetres.

JIC/UNO	S90	S107	S101
---------	-----	------	------

STRAIGHT  
O RING SUPPLIED

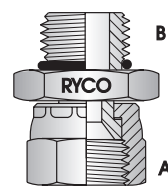
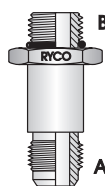
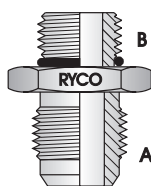

THREAD		DASH SIZE	JIC MALE	JIC MALE EXT	JIC FEMALE SWIVEL
A	B		UN O RING MALE	UN O RING MALE	UN O RING MALE
inch	inch		PART NO	PART NO	PART NO
7/16	7/16	-0707	S90-0707		S101-0707
7/16	9/16	-0709	S90-0709		S101-0709
7/16	3/4	-0712	S90-0712		
1/2	1/2	-0808	S90-0808		
1/2	3/4	-0812	S90-0812		
1/2	7/8	-0814	S90-0814		S101-0814
9/16	7/16	-0907	S90-0907		S101-0907
9/16	1/2	-0908	S90-0908		
9/16	9/16	-0909	S90-0909	S107-0909	S101-0909
9/16	3/4	-0912	S90-0912		S101-0912
9/16	7/8	-0914	S90-0914		S101-0914
9/16	1.1/16	-0917	S90-0917		
3/4	7/16	-1207	S90-1207		
3/4	9/16	-1209	S90-1209		S101-1209
3/4	3/4	-1212	S90-1212	S107-1212	S101-1212
3/4	7/8	-1214	S90-1214		S101-1214
3/4	1.1/16	-1217	S90-1217		S101-1217
3/4	1.5/16	-1221	S90-1221		
7/8	3/4	-1412	S90-1412	S107-1412	S101-1412
7/8	7/8	-1414	S90-1414	S107-1414	S101-1414
7/8	1.1/16	-1417	S90-1417		S101-1417
7/8	1.5/16	-1421	S90-1421		S101-1421
1.1/16	3/4	-1712	S90-1712		S101-1712
1.1/16	7/8	-1714	S90-1714	S107-1714	S101-1714
1.1/16	1.1/16	-1717	S90-1717	S107-1717	S101-1717
1.1/16	1.3/16	-1719	S90-1719		
1.1/16	1.5/16	-1721	S90-1721		S101-1721
1.1/16	1.5/8	-1726	S90-1726		
1.3/16	1.1/16	-1917	S90-1917		
1.3/16	1.3/16	-1919	S90-1919		
1.3/16	1.5/16	-1921	S90-1921		
1.5/16	3/4	-2112	S90-2112		
1.5/16	7/8	-2114	S90-2114		S101-2114
1.5/16	1.1/16	-2117	S90-2117		S101-2117
1.5/16	1.3/16	-2119	S90-2119		
1.5/16	1.5/16	-2121	S90-2121	S107-2121	S101-2121
1.5/16	1.5/8	-2126	S90-2126		
1.5/8	1.1/16	-2617	S90-2617		
1.5/8	1.5/16	-2621	S90-2621		
1.5/8	1.5/8	-2626	S90-2626		S101-2626
1.5/8	1.7/8	-2630	S90-2630		
1.7/8	1.7/8	-3030	S90-3030		S101-3030

INTRODUCTION

ADAPTORS

COUPLINGS

ADAPTORS

TECHNICAL



# ADAPTORS

## JIC ADAPTORS

JIC/UNO	S88	S91	S86
---------	-----	-----	-----

45° ELBOW  
90° ELBOW  
O RING SUPPLIED

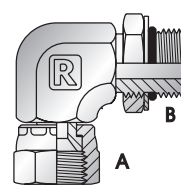
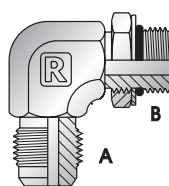
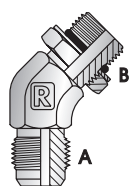

THREAD		DASH SIZE	JIC MALE UN O RING MALE 45° ELBOW	JIC MALE UN O RING MALE 90° ELBOW	JIC FEMALE SWIVEL UN O RING MALE 90° ELBOW
A	B		PART NO	PART NO	PART NO
7/16	7/16	-0707	S88-0707	S91-0707	
7/16	1/2	-0708		S91-0708	
7/16	9/16	-0709		S91-0709	
1/2	1/2	-0808		S91-0808	
9/16	7/16	-0907		S91-0907	
9/16	1/2	-0908		S91-0908	
9/16	9/16	-0909	S88-0909	S91-0909	S86-0909
9/16	3/4	-0912	S88-0912	S91-0912	
9/16	7/8	-0914		S91-0914	
9/16	1.1/16	-0917		S91-0917	
3/4	9/16	-1209		S91-1209	
3/4	3/4	-1212	S88-1212	S91-1212	S86-1212
3/4	7/8	-1214	S88-1214	S91-1214	
3/4	1.1/16	-1217		S91-1217	
3/4	1.5/16	-1221		S91-1221	
7/8	3/4	-1412	S88-1412	S91-1412	S86-1412
7/8	7/8	-1414	S88-1414	S91-1414	S86-1414
7/8	1.1/16	-1417		S91-1417	
1.1/16	3/4	-1712	S88-1712	S91-1712	
1.1/16	7/8	-1714		S91-1714	
1.1/16	1.1/16	-1717	S88-1717	S91-1717	S86-1717
1.1/16	1.3/16	-1719		S91-1719	
1.1/16	1.5/16	-1721		S91-1721	
1.3/16	1.1/16	-1917		S91-1917	
1.3/16	1.3/16	-1919	S88-1919	S91-1919	
1.3/16	1.5/16	-1921		S91-1921	
1.5/16	1.1/16	-2117	S88-2117	S91-2117	
1.5/16	1.3/16	-2119	S88-2119		
1.5/16	1.5/16	-2121	S88-2121	S91-2121	
1.5/16	1.5/8	-2126	S88-2126	S91-2126	
1.5/8	1.5/16	-2621	S88-2621	S91-2621	
1.5/8	1.5/8	-2626	S88-2626	S91-2626	

**JIC/UNO S12**

**EXTENDED  
90° ELBOW  
O RING SUPPLIED**

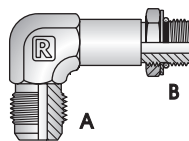

THREAD		DASH SIZE	JIC MALE UN O RING MALE EXTENDED 90° ELBOW
A	B		
inch	inch		PART NO
9/16	9/16	-0909	S12-0909
9/16	7/8	-0914	S12-0914
3/4	3/4	-1212	S12-1212
3/4	7/8	-1214	S12-1214
7/8	7/8	-1414	S12-1414
7/8	1.1/16	-1417	S12-1417
1.1/16	7/8	-1714	S12-1714
1.1/16	1.1/16	-1717	S12-1717
1.5/16	1.5/16	-2121	S12-2121

**JIC/UNO S87**

**TEE  
O RING SUPPLIED**

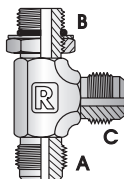

THREAD			DASH SIZE	JIC MALE UN O RING MALE JIC MALE
A	B	C		
inch	inch	inch		PART NO
7/16	7/16	7/16	-070707	S87-070707
7/16	7/8	9/16	-071409	S87-071409
9/16	9/16	9/16	-090909	S87-090909
9/16	3/4	3/4	-091212	S87-091212
3/4	3/4	3/4	-121212	S87-121212
3/4	3/4	7/8	-121214	S87-121214
3/4	7/8	3/4	-121412	S87-121412
7/8	3/4	7/8	-141214	S87-141214
7/8	7/8	3/4	-141412	S87-141412
7/8	7/8	7/8	-141414	S87-141414
7/8	1.1/16	7/8	-141714	S87-141714
7/8	1.1/16	1.1/16	-141717	S87-141717
1.1/16	7/8	1.1/16	-171417	S87-171417
1.1/16	1.1/16	9/16	-171709	S87-171709
1.1/16	1.1/16	3/4	-171712	S87-171712
1.1/16	1.1/16	7/8	-171714	S87-171714
1.1/16	1.1/16	1.1/16	-171717	S87-171717
1.5/16	1.5/16	1.1/16	-212117	S87-212117
1.5/16	1.5/16	1.5/16	-212121	S87-212121

**JIC/UNO S92**

**TEE  
O RING SUPPLIED**

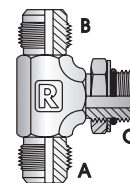

THREAD			DASH SIZE	JIC MALE JIC MALE UN O RING MALE
A	B	C		
inch	inch	inch		PART NO
7/16	7/16	7/16	-070707	S92-070707
1/2	1/2	1/2	-080808	S92-080808
9/16	9/16	7/16	-090907	S92-090907
9/16	9/16	9/16	-090909	S92-090909
9/16	9/16	3/4	-090912	S92-090912
3/4	9/16	3/4	-120912	S92-120912
3/4	3/4	9/16	-121209	S92-121209
3/4	3/4	3/4	-121212	S92-121212
3/4	3/4	7/8	-121214	S92-121214
7/8	3/4	3/4	-141212	S92-141212
7/8	7/8	7/8	-141414	S92-141414
1.1/16	1.1/16	1.1/16	-171717	S92-171717
1.5/16	1.1/16	1.5/16	-211721	S92-211721
1.5/16	1.5/16	1.1/16	-212117	S92-212117
1.5/16	1.5/16	1.5/16	-212121	S92-212121

**JOINER S112**

**TUBE WELD**



TUBE OD	DASH SIZE	JOINER TUBE WELD
inch		PART NO
3/4	-1212	S112-1212
1	-1616	S112-1616
1.1/4	-2020	S112-2020
1.1/2	-2424	S112-2424
2	-3232	S112-3232

INTRODUCTION

ADAPTORS

COUPLINGS

ADAPTORS

TECHNICAL

# ADAPTORS

## METRIC ADAPTORS

### METRIC M73

PLUG  
REQUIRES BONDED  
SEAL (P/N MB)



THREAD A	METRIC PLUG
mm	PART NO
12x1,5	M73-1215
14x1,5	M73-1415
16x1,5	M73-1615
18x1,5	M73-1815
20x1,5	M73-2015
22x1,5	M73-2215
24x1,5	M73-2415
26x1,5	M73-2615
27x2,0	M73-2720
28x1,5	M73-2815
30x2,0	M73-3020
33x2,0	M73-3320
36x2,0	M73-3620
42x2,0	M73-4220
52x2,0	M73-5220

### METRIC MBD

METAL BONDED SEAL  
WITH CENTRALISING LIP



THREAD	DASH SIZE	METRIC METAL BONDED SEAL WITH CENTRALISING LIP	
mm		PART NO	Pack Qty
10	-10	MBD-10	10
12	-12	MBD-12	10
14	-14	MBD-14	10
16	-16	MBD-16	10
18	-18	MBD-18	10
20	-20	MBD-20	10
22	-22	MBD-22	5
24	-24	MBD-24	5
26	-26	MBD-26	5
30	-30	MBD-30	5
28	-28	MBD-28	5
30	-30	MBD-30	5
33	-33	MBD-33	5
36	-36	MBD-36	5
42	-42	MBD-42	5
48	-48	MBD-48	5

**Note:** Bonded Seals are sold only in packs of 5 or 10. Part Number Series for individual seal is MB. Example: Order Part No MB-12 for individual seal. (D is removed from MBD).

### METRIC M6L

DLK LIGHT SERIES  
NUT AND OLIVE  
(CUTTING RING)

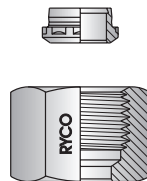

THREAD	TUBE OD	DASH SIZE	DKL NUT AND OLIVE
mm	mm		PART NO
12x1,5	6	-06	M6L-06
14x1,5	8	-08	M6L-08
16x1,5	10	-10	M6L-10
18x1,5	12	-12	M6L-12
22x1,5	15	-15	M6L-15
26x1,5	18	-18	M6L-18
30x2,0	22	-22	M6L-22
36x2,0	28	-28	M6L-28

### METRIC M6S

DKS HEAVY SERIES  
NUT AND OLIVE  
(CUTTING RING)

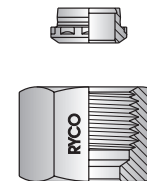

THREAD	TUBE OD	DASH SIZE	DKS NUT AND OLIVE
mm	mm		PART NO
14x1,5	6	-06	M6S-06
16x1,5	8	-08	M6S-08
18x1,5	10	-10	M6S-10
20x1,5	12	-12	M6S-12
22x1,5	14	-14	M6S-14
24x1,5	16	-16	M6S-16
30x2,0	20	-20	M6S-20
36x2,0	25	-25	M6S-25
42x2,0	30	-30	M6S-30
52x2,0	38	-38	M6S-38

METRIC/BSPP O RING	M75L	M75S	M77L	M77S
--------------------	------	------	------	------

STRAIGHT  
90° ELBOW  
BSPP O RING AND RETAINING  
RING SUPPLIED  
METRIC END REQUIRES  
BONDED SEAL (P/N MB)  
IF USED IN A PORT

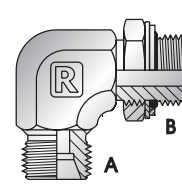
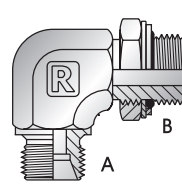
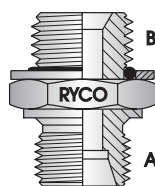
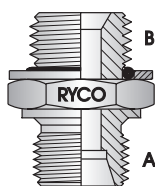

THREAD		DASH SIZE	DKL MALE 24° CONE BSPP O RING MALE		DKS MALE 24° CONE BSPP O RING MALE		DKL MALE 24° CONE BSPP O RING MALE 90° ELBOW		DKS MALE 24° CONE BSPP O RING MALE 90° ELBOW	
A	B		PART NO	Tube OD mm	PART NO	Tube OD mm	PART NO	Tube OD mm	PART NO	Tube OD mm
14x1,5	1/4	-1404	M75L-1404	8						
16x1,5	1/4	-1604			M75S-1604	8				
18x1,5	1/8	-1802			M75S-1802	10				
18x1,5	1/4	-1804			M75S-1804	10	M77L-1804	12	M77S-1804	10
18x1,5	3/8	-1806			M75S-1806	10	M77L-1806	12		
18x1,5	1/2	-1808	M75L-1808	12			M77L-1808	12		
20x1,5	3/8	-2006			M75S-2006	12				
22x1,5	1/2	-2208			M75S-2208	14				
22x1,5	3/4	-2212	M75L-2212	15						
24x1,5	3/8	-2406			M75S-2406	16				
24x1,5	1/2	-2408			M75S-2408	16			M77S-2408	16
30x2,0	1/2	-3008							M77S-3008	20
30x2,0	3/4	-3012			M75S-3012	20				
36x2,0	3/4	-3612			M75S-3612	25			M77S-3612	25
36x2,0	1	-3616			M75S-3616	25				
42x2,0	3/4	-4212							M77S-4212	30
42x2,0	1.1/4	-4220			M75S-4220	30				
52x2,0	1.1/2	-5224			M75S-5224	38				

INTRODUCTION

ADAPTORS

COUPLINGS

ADAPTORS

TECHNICAL

# ADAPTORS

## METRIC ADAPTORS

METRIC/JIC	M7	M7L	M7S
------------	----	-----	-----

**STRAIGHT  
METRIC END REQUIRES  
BONDED SEAL (P/N MB)  
IF USED IN A PORT**

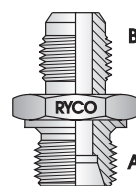
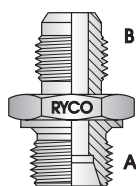
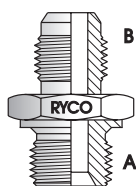

THREAD		DASH SIZE	METRIC MALE JIC MALE	DKL MALE 24° CONE JIC MALE	Tube OD mm	DKS MALE 24° CONE JIC MALE	Tube OD mm
A	B						
inch	inch		PART NO	PART NO			
12x1,5	7/16	-1207		<b>M7L-1207</b>	6		
12x1,5	9/16	-1209		<b>M7L-1209</b>	6		
14x1,5	9/16	-1409		<b>M7L-1409</b>	8		
14x1,5	3/4	-1412		<b>M7L-1412</b>	8		
16x1,5	7/16	-1607	<b>M7-1607</b>	<b>M7L-1607</b>	10		
16x1,5	9/16	-1609	<b>M7-1609</b>				
16x1,5	3/4	-1612	<b>M7-1612</b>				
16x1,5	7/8	-1614	<b>M7-1614</b>				
18x1,5	9/16	-1809				<b>M7S-1809</b>	10
18x1,5	9/16	-1809	<b>M7-1809</b>	<b>M7L-1809</b>	12		
18x1,5	3/4	-1812	<b>M7-1812</b>	<b>M7L-1812</b>	12		
18x1,5	7/8	-1814	<b>M7-1814</b>				
20x1,5	3/4	-2012	<b>M7-2012</b>				
20x1,5	7/8	-2014	<b>M7-2014</b>				
20x1,5	1.1/16	-2017	<b>M7-2017</b>				
22x1,5	3/4	-2212		<b>M7L-2212</b>	15		
22x1,5	7/8	-2214		<b>M7L-2214</b>	15		
22x1,5	1.1/16	-2217	<b>M7-2217</b>				
24x1,5	3/4	-2412				<b>M7S-2412</b>	16
24x1,5	1.1/16	-2417				<b>M7S-2417</b>	16
26x1,5	1.1/16	-2617	<b>M7-2617</b>				
26x1,5	1.5/16	-2621	<b>M7-2621</b>				
27x2,0	1.1/16	-2717	<b>M7-2717</b>				
27x2,0	1.5/16	-2721	<b>M7-2721</b>				
28x1,5	1.1/16	-2817	<b>M7-2817</b>				
28x1,5	1.5/16	-2821	<b>M7-2821</b>				
30x2,0	7/8	-3014				<b>M7S-3014</b>	20
33x2,0	1.1/16	-3317	<b>M7-3317</b>				
33x2,0	1.5/16	-3321	<b>M7-3321</b>				
33x2,0	1.5/8	-3326	<b>M7-3326</b>				
36x2,0	1.1/16	-3617				<b>M7S-3617</b>	25
42x2,0	1.5/16	-4221	<b>M7-4221</b>			<b>M7S-4221</b>	30
42x2,0	1.5/8	-4226	<b>M7-4226</b>				
42x2,0	1.7/8	-4230	<b>M7-4230</b>				
48x2,0	1.5/8	-4826	<b>M7-4826</b>				
48x2,0	1.7/8	-4830	<b>M7-4830</b>				

<b>METRIC/JIC</b>	<b>M71L</b>	<b>M71S</b>
-------------------	-------------	-------------

**STRAIGHT  
METRIC END REQUIRES  
BONDED SEAL (P/N MB)  
IF USED IN A PORT**

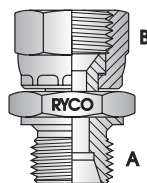
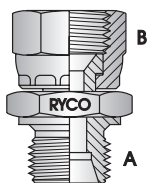

THREAD		DASH SIZE	DKL MALE 24° CONE JIC FEMALE		DKS MALE 24° CONE JIC FEMALE	
A	B		part no	Tube OD mm	part no	Tube OD mm
18x1,5	7/16	-1807			<b>M71S-1807</b>	10
18x1,5	9/16	-1809			<b>M71S-1809</b>	10
18x1,5	9/16	-1809	<b>M71L-1809</b>	12		
24x1,5	3/4	-2412			<b>M71S-2412</b>	16
30x2,0	1.1/16	-3017			<b>M71S-3017</b>	20

<b>ORFS</b>	<b>S111</b>	<b>S113</b>
-------------	-------------	-------------

**PLUG  
CAP  
O RING INCLUDED**

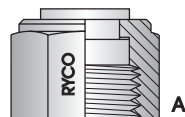

THREAD A	DASH SIZE	ORFS MALE PLUG	ORFS FEMALE CAP
inch		PART NO	PART NO
9/16	-09	<b>S111-09</b>	<b>S113-09</b>
11/16	-11	<b>S111-11</b>	<b>S113-11</b>
13/16	-13	<b>S111-13</b>	<b>S113-13</b>
1	-16	<b>S111-16</b>	<b>S113-16</b>
1.3/16	-19	<b>S111-19</b>	<b>S113-19</b>
1.7/16	-23	<b>S111-23</b>	<b>S113-23</b>
1.11/16	-27	<b>S111-27</b>	<b>S113-27</b>
2	-32	<b>S111-32</b>	<b>S113-32</b>

<b>ORFS</b>	<b>S115</b>	<b>S106</b>
-------------	-------------	-------------

**TUBE WELD  
O RING INCLUDED**

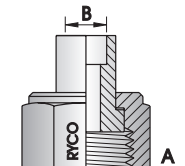
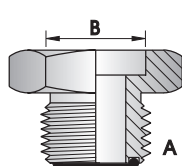

THREAD A	TUBE OD B	DASH SIZE	ORFS MALE TUBE WELD	ORFS FEMALE SWIVEL TUBE WELD
inch	inch		PART NO	PART NO
9/16	1/4	-0904	<b>S115-0904</b>	<b>S106-0904</b>
11/16	3/8	-1106	<b>S115-1106</b>	<b>S106-1106</b>
13/16	1/2	-1308	<b>S115-1308</b>	<b>S106-1308</b>
1	5/8	-1610	<b>S115-1610</b>	<b>S106-1610</b>
1.3/16	3/4	-1912	<b>S115-1912</b>	<b>S106-1912</b>
1.7/16	1	-2316	<b>S115-2316</b>	<b>S106-2316</b>
1.11/16	1.1/4	-2720	<b>S115-2720</b>	<b>S106-2720</b>

INTRODUCTION

ADAPTORS

COUPLINGS

ADAPTORS

TECHNICAL

# ADAPTORS

## ORFS ADAPTORS

ORFS/ORFS	S116	S141	S117
-----------	------	------	------

STRAIGHT  
BULKHEAD NIPPLE  
90° ELBOW  
O RINGS INCLUDED

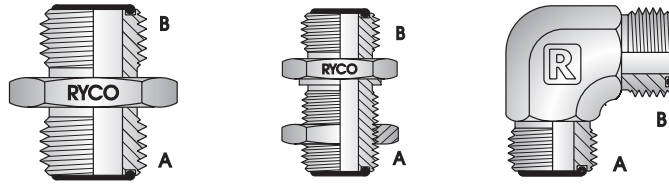

THREAD		DASH SIZE	ORFS MALE ORFS MALE	ORFS MALE BULKHEAD ORFS MALE	ORFS MALE ORFS MALE 90° ELBOW
A	B				
inch	inch		PART NO	PART NO	PART NO
9/16	9/16	-0909	S116-0909	S141-0909	S117-0909
11/16	9/16	-1109	S116-1109		
11/16	11/16	-1111	S116-1111	S141-1111	S117-1111
13/16	11/16	-1311	S116-1311		
13/16	13/16	-1313	S116-1313	S141-1313	S117-1313
1	13/16	-1613	S116-1613		
1	1	-1616	S116-1616	S141-1616	S117-1616
1.3/16	9/16	-1909	S116-1909		
1.3/16	13/16	-1913	S116-1913		
1.3/16	1	-1916	S116-1916		
1.3/16	1.3/16	-1919	S116-1919	S141-1919	S117-1919
1.7/16	1.3/16	-2319	S116-2319		
1.7/16	1.7/16	-2323	S116-2323	S141-2323	S117-2323
1.11/16	1.11/16	-2727		S141-2727	

ORFS/ORFS	S118	S154
-----------	------	------

STRAIGHT  
BULKHEAD NIPPLE  
90° ELBOW  
O RINGS INCLUDED

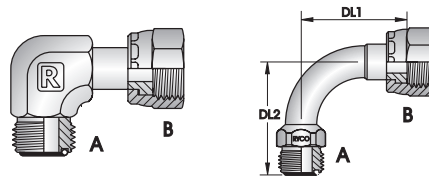

THREAD		DASH SIZE	ORFS MALE ORFS FEMALE SWIVEL 90° ELBOW	ORFS MALE ORFS MALE 90° ELBOW	DL1	DL2
A	B					
inch	inch		PART NO	PART NO		
9/16	9/16	-0909	S118-0909			
11/16	11/16	-1111	S118-1111			
13/16	13/16	-1313	S118-1313			
1	1	-1616	S118-1616			
1.3/16	1.3/16	-1919	S118-1919			
1.7/16	1.7/16	-2323	S118-2323	S154-2323	84	80

NOTE: Drop Lengths (DL) dimensions are in millimetres.



<b>ORFS/ORFS</b>	<b>S119</b>	<b>S120</b>	<b>S121</b>
------------------	-------------	-------------	-------------

TEE  
O RINGS INCLUDED

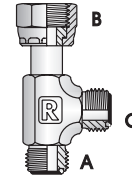
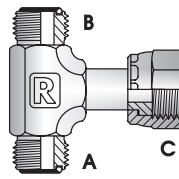
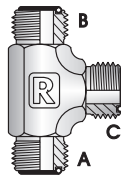

THREAD			DASH SIZE	ORFS MALE	ORFS MALE	ORFS MALE
A	B	C		ORFS MALE	ORFS FEMALE SWIVEL	ORFS FEMALE SWIVEL
inch	inch	inch		PART NO	PART NO	PART NO
9/16	9/16	9/16	-090909	S119-090909	S120-090909	S121-090909
11/16	11/16	11/16	-111111	S119-111111		S121-111111
13/16	13/16	13/16	-131313	S119-131313	S120-131313	S121-131313
1	1	13/16	-161613			S121-161613
1	1	1	-161616	S119-161616	S120-161616	S121-161616
1.3/16	1.3/16	13/16	-191913			S121-191913
1.3/16	1.3/16	1.3/16	-191919	S119-191919	S120-191919	S121-191919
1.7/16	1.7/16	1.7/16	-232323	S119-232323	S120-232323	S121-232323

<b>ORFS/UNO</b>	<b>S122</b>	<b>S123</b>	<b>S124</b>	<b>S125</b>
-----------------	-------------	-------------	-------------	-------------

STRAIGHT  
45° ELBOW  
90° ELBOW  
O RINGS INCLUDED

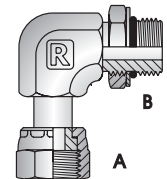
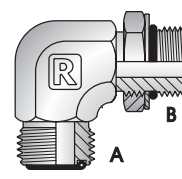
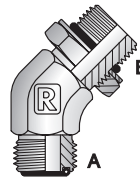
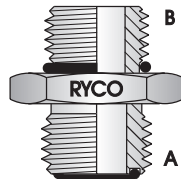

THREAD		DASH SIZE	ORFS MALE	ORFS MALE	ORFS MALE	ORFS FEMALE SWIVEL
A	B		UN O RING MALE	UN O RING MALE	UN O RING MALE	UN O RING MALE
inch	inch		PART NO	PART NO	PART NO	PART NO
9/16	7/16	-0907	S122-0907	S123-0907	S124-0907	S125-0907
9/16	9/16	-0909	S122-0909	S123-0909	S124-0909	
9/16	3/4	-0912	S122-0912			
11/16	7/16	-1107	S122-1107	S123-1107	S124-1107	
11/16	9/16	-1109	S122-1109	S123-1109	S124-1109	S125-1109
13/16	9/16	-1309	S122-1309		S124-1309	
13/16	3/4	-1312	S122-1312	S123-1312	S124-1312	S125-1312
13/16	7/8	-1314	S122-1314			
13/16	1.1/16	-1317	S122-1317			
1	3/4	-1612	S122-1612		S124-1612	
1	7/8	-1614	S122-1614	S123-1614	S124-1614	S125-1614
1	1.1/16	-1617	S122-1617			
1.3/16	7/8	-1914	S122-1914		S124-1914	
1.3/16	1.1/16	-1917	S122-1917	S123-1917	S124-1917	S125-1917
1.3/16	1.5/16	-1921	S122-1921			
1.7/16	1.1/16	-2317	S122-2317			
1.7/16	1.5/16	-2321	S122-2321	S123-2321	S124-2321	S125-2321
1.11/16	1.5/8	-2726	S122-2726			
2	1.5/8	-3226	S122-3226			

INTRODUCTION

ADAPTORS

COUPLINGS

ADAPTORS

TECHNICAL

# ADAPTORS

## ORFS ADAPTORS

<b>ORFS/UNO</b>	<b>S126</b>
-----------------	-------------

**TEE  
O RINGS INCLUDED**

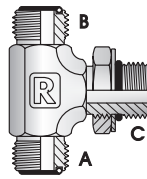

THREAD			DASH SIZE	ORFS MALE ORFS MALE UN O RING MALE
A	B	C		
inch	inch	inch		PART NO
13/16	13/16	3/4	-131312	S126-131312

<b>ORFS/UNO</b>	<b>S127</b>
-----------------	-------------

**TEE  
O RINGS INCLUDED**

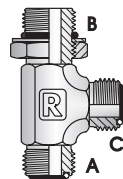

THREAD			DASH SIZE	ORFS MALE UN O RING MALE ORFS MALE
A	B	C		
inch	inch	inch		PART NO
9/16	7/16	9/16	-090709	S127-090709
11/16	9/16	11/16	-110911	S127-110911
13/16	3/4	13/16	-131213	S127-131213
1	7/8	1	-161416	S127-161416
1.3/16	1.1/16	1.3/16	-191719	S127-191719
1.7/16	1.5/16	1.7/16	-232123	S127-232123
1.11/16	1.5/8	1.11/16	-272627	S127-272627

<b>SAE</b>	<b>SA51</b>	<b>SA6</b>
------------	-------------	------------

**TUBE WELD  
TUBE NUT &  
SLEEVE  
(FLARE TYPE)**

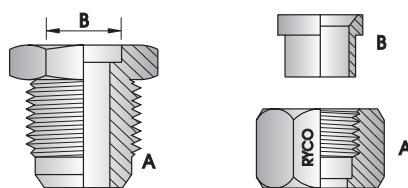

THREAD A	TUBE OD B	DASH SIZE	SAE MALE TUBE WELD	SAE FEMALE NUT AND SLEEVE
inch	inch		PART NO	PART NO
5/8	3/8	-1006	SA51-1006	SA6-1006
1.1/16	3/4	-1712		SA6-1712

<b>SAE/SAE</b>	<b>SA17</b>	<b>SA10</b>	<b>SA23</b>
----------------	-------------	-------------	-------------

**STRAIGHT  
BULKHEAD NIPPLE  
45° ELBOW**

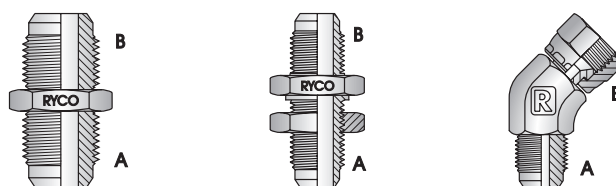

THREAD		DASH SIZE	SAE MALE SAE MALE	SAE MALE BULKHEAD SAE MALE	SAE MALE SAE FEMALE SWIVEL 45° ELBOW
A	B				
inch	inch		PART NO	PART NO	PART NO
7/16	7/16	-0707	SA17-0707		
1/2	1/2	-0808	SA17-0808	SA10-0808	
5/8	5/8	-1010	SA17-1010		SA23-1010
3/4	3/4	-1212	SA17-1212	SA10-1212	
7/8	7/8	-1414	SA17-1414		
1.1/16	1.1/16	-1717	SA17-1717		

<b>SAE/SAE</b>	<b>SA18</b>	<b>SA15</b>
----------------	-------------	-------------

**90° ELBOW**

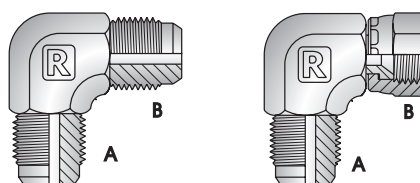

THREAD		DASH SIZE	SAE MALE SAE MALE 90° ELBOW	SAE MALE SAE FEMALE SWIVEL 90° ELBOW
A	B			
inch	inch		PART NO	PART NO
5/8	5/8	-1010	SA18-1010	SA15-1010
3/4	3/4	-1212		SA15-1212
7/8	7/8	-1414		SA15-1414
1.1/16	1.1/16	-1717		SA15-1717

INTRODUCTION

ADAPTORS

COUPLINGS

ADAPTORS

TECHNICAL

# ADAPTORS

## SAE ADAPTORS

<b>SAE/SAE</b>	<b>SA19</b>
----------------	-------------

TEE

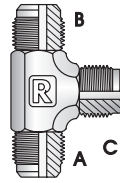

THREAD			DASH SIZE	SAE MALE SAE MALE SAE MALE
A	B	C		
inch	inch	inch		PART NO
5/8	5/8	5/8	-101010	SA19-101010

<b>SAE FLANGE CLAMPS</b>	<b>S40</b>	<b>S42</b>	<b>S140</b>	<b>S142</b>
--------------------------	------------	------------	-------------	-------------

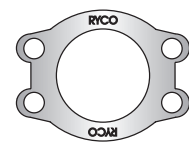
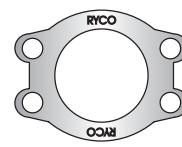
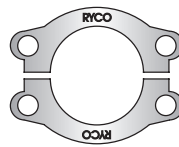
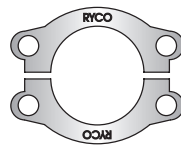

NOMINAL FLANGE	DASH SIZE	SPLIT FLANGE CLAMPS CODE 61 SUPPLIED IN PAIRS	SPLIT FLANGE CLAMPS CODE 62 SUPPLIED IN PAIRS	SOLID FLANGE CLAMP CODE 61	SOLID FLANGE CLAMP CODE 62
inch		PART NO	PART NO	PART NO	PART NO
1/2	-08	S40-08	S42-08	S140-08	S142-08
3/4	-12	S40-12	S42-12	S140-12	S142-12
1	-16	S40-16	S42-16	S140-16	S142-16
1.1/4	-20	S40-20	S42-20	S140-20	S142-20
1.1/2	-24	S40-24	S42-24	S140-24	S142-24
2	-32	S40-32	S42-32	S140-32	S142-32
2.1/2	-40	S40-40		S140-40	
3	-48	S40-48		S140-48	
4	-64	S40-64		S140-64	

<b>SAE FLANGE CLAMP KITS - UNC BOLTS</b>	<b>S40K</b>	<b>S42K</b>	<b>S140K</b>	<b>S142K</b>
--	-------------	-------------	--------------	--------------

WITH O RING  
BOLTS &  
WASHERS

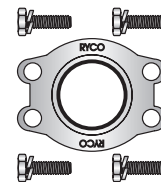
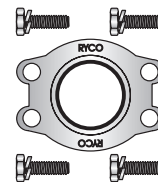
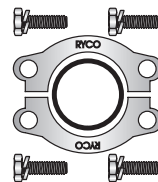
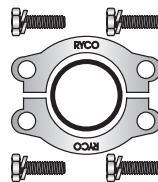

NOMINAL FLANGE	DASH SIZE	UNC BOLTS SPLIT FLANGE CLAMP KITS CODE 61	UNC BOLTS SPLIT FLANGE CLAMP KITS CODE 62	UNC BOLTS SOLID FLANGE CLAMP KITS CODE 61	UNC BOLTS SOLID FLANGE CLAMP KITS CODE 62
inch		PART NO	PART NO	PART NO	PART NO
1/2	-08	S40K-08	S42K-08	S140K-08	S142K-08
3/4	-12	S40K-12	S42K-12	S140K-12	S142K-12
1	-16	S40K-16	S42K-16	S140K-16	S142K-16
1.1/4	-20	S40K-20	S42K-20	S140K-20	S142K-20
1.1/2	-24	S40K-24	S42K-24	S140K-24	S142K-24
2	-32	S40K-32	S42K-32	S140K-32	S142K-32
2.1/2	-40	S40K-40		S140K-40	

<b>SAE FLANGE CLAMP KITS - METRIC BOLTS</b>	<b>S40M</b>	<b>S42M</b>	<b>S140M</b>	<b>S142M</b>
---	-------------	-------------	--------------	--------------

WITH O RING,  
BOLTS &  
WASHERS

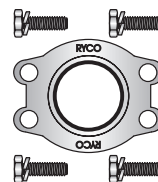
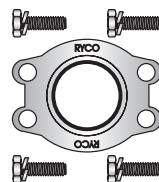
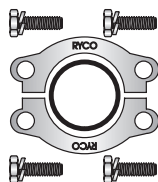
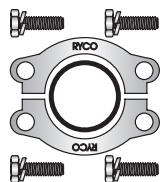

NOMINAL FLANGE	DASH SIZE	METRIC BOLTS SPLIT FLANGE CLAMP KITS CODE 61	METRIC BOLTS SPLIT FLANGE CLAMP KITS CODE 62	METRIC BOLTS SOLID FLANGE CLAMP KITS CODE 61	METRIC BOLTS SOLID FLANGE CLAMP KITS CODE 62
inch		PART NO	PART NO	PART NO	PART NO
1/2	-08	S40M-08	S42M-08	S140M-08	S142M-08
3/4	-12	S40M-12	S42M-12	S140M-12	S142M-12
1	-16	S40M-16	S42M-16	S140M-16	S142M-16
1.1/4	-20	S40M-20	S42M-20	S140M-20	S142M-20
1.1/2	-24	S40M-24	S42M-24	S140M-24	S142M-24
2	-32	S40M-32	S42M-32	S140M-32	S142M-32
2.1/2	-40	S40M-40		S140M-40	

**DIMENSIONS OF SAE FLANGES & FLANGE CLAMPS**

NOM. FLANGE	DASH SIZE	BØ		T		F		G		PORT THREAD & BOLT LENGTH			
		mm	inch	mm	inch	mm	inch	mm	inch	PORT	BOLT	PORT	BOLT
inch		mm	inch	mm	inch	mm	inch	mm	inch	UNC	inch	METRIC	mm
<b>CODE 61</b>													
1/2	-08	30,2	1.19	6,73	0.265	17,5	0.69	38,1	1.50	5/16 - 18	1.1/4	M8 x 1,25	35
*5/8	-10	34,0	1.34	6,73	0.265	19,8	0.78	42,9	1.69	5/16 - 18		M8 x 1,25	
3/4	-12	38,1	1.50	6,73	0.265	22,2	0.88	47,6	1.88	3/8 - 16	1.1/4	M10 x 1,5	35
1	-16	44,5	1.75	8,00	0.315	26,2	1.03	52,4	2.06	3/8 - 16	1.1/4	M10 x 1,5	35
1.1/4	-20	50,8	2.00	8,00	0.315	30,2	1.19	58,7	2.31	7/16 - 14	1.1/2	M10 x 1,5	40
1.1/2	-24	60,3	2.38	8,00	0.315	35,7	1.41	69,8	2.75	1/2 - 13	1.1/2	M12 x 1,75	45
2	-32	71,4	2.81	9,53	0.375	42,9	1.69	77,8	3.06	1/2 - 13	1.1/2	M12 x 1,75	45
2.1/2	-40	84,1	3.31	9,53	0.375	50,8	2.00	88,9	3.50	1/2 - 13	1.3/4	M12 x 1,75	45
3	-48	101,6	4.00	9,53	0.375	61,9	2.44	106,4	4.19	5/8 - 11	1.3/4	M16 x 2,0	45
<b>CODE 62</b>													
1/2	-08	31,7	1.25	7,75	0.305	18,2	0.72	40,5	1.59	5/16 - 18	1.1/4	M8 x 1,25	35
3/4	-12	41,3	1.63	8,76	0.345	23,8	0.94	50,8	2.00	3/8 - 16	1.1/2	M10 x 1,5	40
1	-16	47,6	1.88	9,53	0.375	27,8	1.09	57,2	2.25	7/16 - 14	1.3/4	M12 x 1,75	45
1.1/4	-20	54,0	2.12	10,29	0.405	31,8	1.25	66,7	2.63	1/2 - 13	1.3/4	M14 x 2,0	45
1.1/2	-24	63,5	2.50	12,57	0.495	36,5	1.44	79,4	3.13	5/8 - 11	2.1/4	M16 x 2,0	60
2	-32	79,4	3.13	12,57	0.495	44,5	1.75	96,8	3.81	3/4 - 10	2.3/4	M20 x 2,5	70

\*NOTE: 5/8 is used by Komatsu.

# ADAPTORS

## SAE ADAPTORS

SAE FLANGE	S979	S980
------------	------	------

**BLANK PLUG  
O RING NOT SUPPLIED**



NOMINAL FLANGE	DASH SIZE	BLANK PLUG CODE 61	BLANK PLUG CODE 62
inch		PART NO	PART NO
1/2	-08	S979-08	S980-08
3/4	-12	S979-12	S980-12
1	-16	S979-16	S980-16
1.1/4	-20	S979-20	S980-20
1.1/2	-24	S979-24	S980-24
2	-32	S979-32	S980-32
2.1/2	40	S979-40	

**NOTE:** Flat Face side will seal against O Ring port. O Ring side will seal against Flat Face port.  
O Ring not supplied.  
**FLANGE OD** can be found on page 441, **CLAMPS** can be found on page 440.

SAE FLANGE	S981	S982	S982C
------------	------	------	-------

**TUBE WELD  
O RING NOT SUPPLIED  
\*(5/8 KOMATSU)**

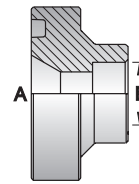
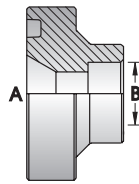
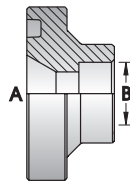

NOM. FLANGE A	TUBE OD B	DASH SIZE	CODE 61 O RING FACE SOCKET WELD	CODE 62 O RING FACE SOCKET WELD	RYCO CODE 62C O RING FACE SOCKET WELD
inch	inch		PART NO	PART NO	PART NO
1/2	5/8	-0810	S981-0810		
*5/8	5/8	-1010	S981-1010		
3/4	5/8	-1210	S981-1210		
3/4	3/4	-1212	S981-1212	S982-1212	S982C-1212
3/4	1	-1216		S982-1216	
1	3/4	-1612	S981-1612	S982-1612	S982C-1612
1	1	-1616	S981-1616	S982-1616	S982C-1616
1	1.1/4	-1620	S981-1620		
1.1/4	1	-2016	S981-2016	S982-2016	S982C-2016
1.1/4	1.1/4	-2020	S981-2020	S982-2020	S982C-2020
1.1/4	1.1/2	-2024	S981-2024		
1.1/2	1.1/4	-2420	S981-2420	S982-2420	S982C-2420
1.1/2	1.1/2	-2424	S981-2424	S982-2424	S982C-2424
2	1.1/4	-3220	S981-3220		
2	1.1/2	-3224	S981-3224	S982-3224	
2	2	-3232	S981-3232	S982-3232	
2.1/2	2	-4032	S981-4032		
2.1/2	2.1/2	-4040	S981-4040		

**NOTE:** **FLANGE OD** can be found on page 441, **CLAMPS** can be found on page 440.

SAE FLANGE/JIC	S1	S3	S2	S2L
----------------	----	----	----	-----

CODE 61  
O RING NOT SUPPLIED

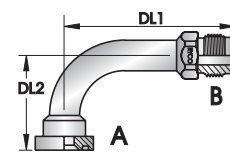
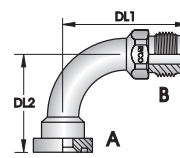
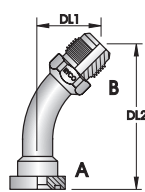
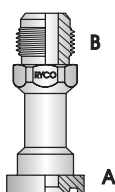

NOM. FLANGE A	THREAD B	DASH SIZE	CODE 61 FLANGE JIC MALE	CODE 61 FLANGE JIC MALE 45° TUBE BEND	CODE 61 FLANGE JIC MALE 90° TUBE BEND	CODE 61 FLANGE JIC MALE 90° LONG BEND						
inch	inch		PART NO	PART NO	DL1	DL2	PART NO	DL1	DL2	PART NO	DL1	DL2
1/2	3/4	-0812	S1-0812	S3-0812	32	61	S2-0812	58	41			
1/2	7/8	-0814					S2-0814	68	46			
3/4	3/4	-1212	S1-1212				S2-1212	57	46			
3/4	7/8	-1214	S1-1214	S3-1214	38	71	S2-1214	66	50			
3/4	1.1/16	-1217	S1-1217	S3-1217	41	82	S2-1217	75	56			
1	1.1/16	-1617	S1-1617	S3-1617	46	85	S2-1617	78	61			
1	1.5/16	-1621	S1-1621	S3-1621	46	94	S2-1621	88	66	S2L-1621	116	66
1.1/4	1.1/16	-2017					S2-2017	77	62			
1.1/4	1.5/16	-2021	S1-2021	S3-2021	48	96	S2-2021	89	69			
1.1/4	1.5/8	-2026	S1-2026	S3-2026	53	110	S2-2026	104	81			
1.1/2	1.5/16	-2421	S1-2421				S2-2421	87	74			
1.1/2	1.5/8	-2426	S1-2426	S3-2426	55	113	S2-2426	100	86			
1.1/2	1.7/8	-2430	S1-2430	S3-2430	67	125	S2-2430	127	93			
2	1.5/8	-3226					S2-3226	106	88			
2	1.7/8	-3230	S1-3220									
2	2.1/2	-3240					S2-3240	152	125			

NOTE: Drop Lengths (DL) dimensions are in millimetres.  
FLANGE OD can be found on page 441, CLAMPS can be found on page 440.

SAE FLANGE/JIC	S1H	S3H	S2H
----------------	-----	-----	-----

CODE 62  
O RING NOT SUPPLIED

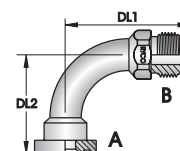
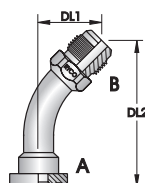
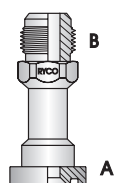

NOM. FLANGE A	THREAD B	DASH SIZE	CODE 62 FLANGE JIC MALE	CODE 62 FLANGE JIC MALE 45° TUBE BEND	CODE 62 FLANGE JIC MALE 90° TUBE BEND				
inch	inch		PART NO	PART NO	DL1	DL2	PART NO	DL1	DL2
3/4	7/8	-1214					S2H-1214	66	52
3/4	1.1/16	-1217	S1H-1217	S3H-1217	48	82	S2H-1217	79	55
3/4	1.5/16	-1221					S2H-1221	83	55
1	1.1/16	-1617	S1H-1617				S2H-1617	78	60
1	1.5/16	-1621	S1H-1621	S3H-1621	50	95	S2H-1621	87	69
1.1/4	1.1/16	-2017					S2H-2017	76	66
1.1/4	1.5/16	-2021	S1H-2021						
1.1/4	1.5/8	-2026					S2H-2026	105	79
1.1/2	1.5/16	-2421	S1H-2421				S2H-2421	77	90
1.1/2	1.5/8	-2426	S1H-2426				S2H-2426	102	88
2	2.1/2	-3240					S2H-3240	149	131

NOTE: Drop Lengths (DL) dimensions are in millimetres.  
FLANGE OD can be found on page 441, CLAMPS can be found on page 440.

INTRODUCTION

ADAPTORS

COUPLINGS

ADAPTORS

TECHNICAL



# ADAPTORS

## SAE ADAPTORS & SAE FLANGE BLOCKS

SAE FLANGE/ORFS	S147H	S146H	S143H
-----------------	-------	-------	-------

CODE 62  
SAE FLANGE  
O RING NOT SUPPLIED

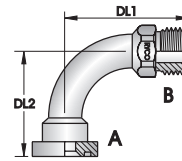
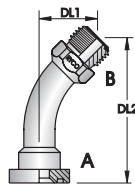
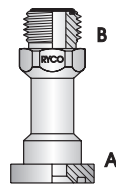

NOM. FLANGE A	THREAD B	DASH SIZE	CODE 62 FLANGE ORFS MALE	CODE 62 FLANGE ORFS MALE 45° TUBE BEND	CODE 62 FLANGE ORFS MALE 90° TUBE BEND
inch	inch		PART NO	PART NO	PART NO
1	1.7/16	-1623	S147H-1623	S146H-1623	S143H-1623
1.1/2	2	-2432			S143H-2432

NOTE: Drop Lengths (DL) dimensions are in millimetres.  
FLANGE OD can be found on page 441, CLAMPS can be found on page 440.

### ADAPTORS – SAE FLANGE BLOCKS

RYCO SAE Flange Blocks shown on pages <?> to <?> incorporate the SAE Flange Head and the SAE Flange Clamp into a single forged carbon steel unit.

RYCO SAE Flange Blocks with O Ring groove have unthreaded bolt holes.

RYCO Flat Flange blocks **S940F**, **S941F**, **S970F**, **S971F**, **S976F**, **S977F**, **S951F** and **S952F** have UNC threaded bolt holes for use with **FK61** and **FK62** Fastening Kits. (NOTE suffix "F" means Flat Face with UNC threaded bolt holes).

RYCO Flat Flange blocks **S940FM**, **S941FM**, **S970FM**, **S971FM**, **S951FM** and **S952FM** have METRIC threaded bolt holes for use with **FK61M** and **FK62M** Fastening Kits. (NOTE suffix "FM" means Flat Face with METRIC threaded bolt holes).

#### FOR DIMENSIONS OF SAE FLANGE BLOCKS, SEE PAGE 510.

Due to restricted clearance on the neck of Socket Weld and BSPP Female Flange Blocks, Hex Head Bolts cannot be used. **FK61**, **FK61M**, **FK62** and **FK62M** Fastening Kits, which include Socket Head Cap Bolts and special Square Section Spring Washers, must be used.

Blind, Butt Weld, BSPP Male and JIC Male Flange Blocks may be used with Hex Head Bolts and standard Spring Washers if preferred.

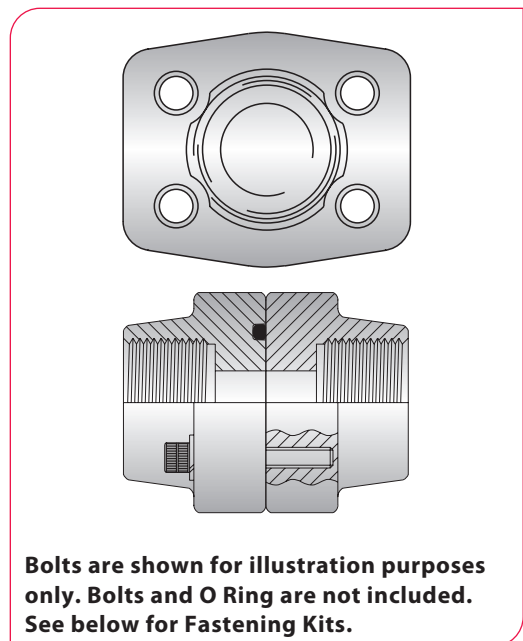

Bolts are shown for illustration purposes only. Bolts and O Ring are not included. See below for Fastening Kits.

SAE FLANGE BLOCKS	FK61	FK62	FK61M	FK62M
-------------------	------	------	-------	-------

FASTENING KITS  
WITH O RING,  
SOCKET HEAD  
CAP BOLTS  
& WASHERS

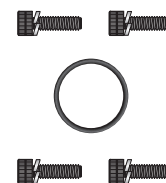
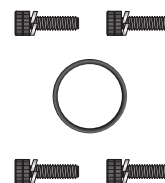
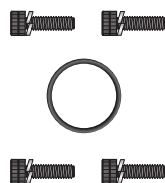
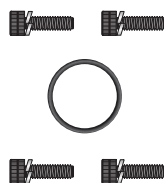

NOM. FLANGE SIZE	DASH SIZE	SUITS SAE FLANGE BLOCKS CODE 61, UNC BOLTS	SUITS SAE FLANGE BLOCKS CODE 62, UNC BOLTS	SUITS SAE FLANGE BLOCKS CODE 61, METRIC BOLTS	SUITS SAE FLANGE BLOCKS CODE 62, METRIC BOLTS
inch		PART NO	PART NO	PART NO	PART NO
1/2	-08	FK61-08	FK62-08	FK61M-08	FK62M-08
3/4	-12	FK61-12	FK62-12	FK61M-12	FK62M-12
1	-16	FK61-16	FK62-16	FK61M-16	FK62M-16
1.1/4	-20	FK61-20	FK62-20	FK61M-20	FK62M-20
1.1/2	-24	FK61-24	FK62-24	FK61M-24	FK62M-24
2	-32	FK61-32	FK62-32	FK61M-32	FK62M-32

<b>SAE FLANGE BLOCKS</b>	<b>S967</b>	<b>S968</b>
--------------------------	-------------	-------------

BLIND BLANKING  
FLANGE  
O RING & BOLTS  
NOT SUPPLIED



NOM. FLANGE SIZE	DASH SIZE	CODE 61 FLANGE BLIND	CODE 62 FLANGE BLIND
inch		PART NO	PART NO
1/2	-08	S967-08	S968-08
3/4	-12	S967-12	S968-12
1	-16	S967-16	S968-16
1.1/4	-20	S967-20	S968-20
1.1/2	-24	S967-24	S968-24
2	-32	S967-32	S968-32

<b>SAE FLANGE BLOCKS</b>	<b>S940</b>	<b>S940F</b>	<b>S940FM</b>
--------------------------	-------------	--------------	---------------

CODE 61  
SOCKET WELD  
TO SUIT IMPERIAL TUBE  
O RING & BOLTS NOT SUPPLIED

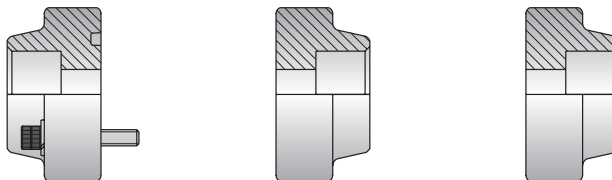

NOM. FLANGE SIZE	NOM. TUBE SIZE	DASH SIZE	TO SUIT TUBE OD	CODE 61 FLANGE SOCKET WELD TUBE	CODE 61 FLANGE FLAT SOCKET WELD TUBE UNC BOLT HOLES	CODE 61 FLANGE FLAT SOCKET WELD TUBE METRIC BOLT HOLES
inch	inch		mm	PART NO	PART NO	PART NO
1/2	1/2	-0808	12,7	S940-0808	S940F-0808	S940FM-0808
3/4	3/4	-1212	19,1	S940-1212	S940F-1212	S940FM-1212
1	1	-1616	25,4	S940-1616	S940F-1616	S940FM-1616
1.1/4	1.1/4	-2020	31,8	S940-2020	S940F-2020	S940FM-2020
1.1/2	1.1/2	-2424	38,1	S940-2424	S940F-2424	S940FM-2424
2	2	-3232	50,8	S940-3232	S940F-3232	S940FM-3232

<b>SAE FLANGE BLOCKS</b>	<b>S941</b>	<b>S941F</b>	<b>S941FM</b>
--------------------------	-------------	--------------	---------------

CODE 62  
SOCKET WELD  
TO SUIT IMPERIAL TUBE  
O RING & BOLTS NOT SUPPLIED

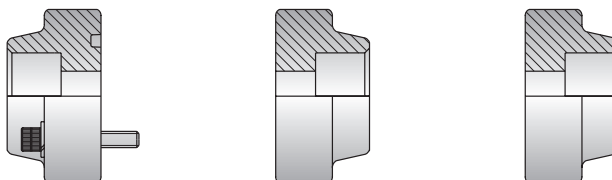

NOM. FLANGE SIZE	NOM. TUBE SIZE	DASH SIZE	TO SUIT TUBE OD	CODE 62 FLANGE SOCKET WELD TUBE	CODE 62 FLANGE FLAT SOCKET WELD TUBE UNC BOLT HOLES	CODE 62 FLANGE FLAT SOCKET WELD TUBE METRIC BOLT HOLES
inch	inch		mm	PART NO	PART NO	PART NO
3/4	3/4	-1212	19,1	S941-1212	S941F-1212	S941FM-1212
1	1	-1616	25,4	S941-1616	S941F-1616	S941FM-1616
1.1/4	1.1/4	-2020	31,8	S941-2020	S941F-2020	S941FM-2020
1.1/2	1.1/2	-2424	38,1	S941-2424	S941F-2424	S941FM-2424
2	2	-3232	50,8	S941-3232	S941F-3232	S941FM-3232

**NOTE:** Bolts are shown for illustration purposes only. Bolts and O Ring are not included. See page 444 for Fastening Kits.

# ADAPTORS

## SAE FLANGE BLOCKS

SAE FLANGE BLOCKS	S970	S970F	S970FM
-------------------	------	-------	--------

**CODE 61**  
**SOCKET WELD**  
**TO SUIT IMPERIAL PIPE**  
**O RING & BOLTS NOT SUPPLIED**

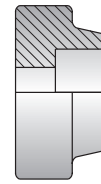
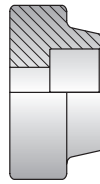
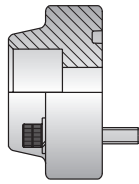

NOM. FLANGE SIZE	NOM. PIPE SIZE	DASH SIZE	TO SUIT PIPE OD	CODE 61 FLANGE SOCKET WELD PIPE	CODE 61 FLANGE FLAT SOCKET WELD PIPE UNC BOLT HOLES	CODE 61 FLANGE FLAT SOCKET WELD PIPE METRIC BOLT HOLES
inch	inch		mm	PART NO	PART NO	PART NO
1/2	1/2	-0808	21,3	S970-0808	S970F-0808	S970FM-0808
3/4	3/4	-1212	26,7	S970-1212	S970F-1212	S970FM-1212
1	1	-1616	33,4	S970-1616	S970F-1616	S970FM-1616
1.1/4	1.1/4	-2020	42,2	S970-2020	S970F-2020	S970FM-2020
1.1/2	1.1/2	-2424	48,3	S970-2424	S970F-2424	S970FM-2424
2	2	-3232	60,3	S970-3232	S970F-3232	S970FM-3232

SAE FLANGE BLOCKS	S971	S971F	S971FM
-------------------	------	-------	--------

**CODE 62**  
**SOCKET WELD**  
**TO SUIT IMPERIAL PIPE**  
**O RING & BOLTS NOT SUPPLIED**

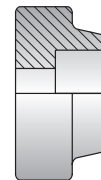
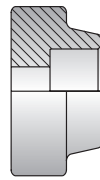
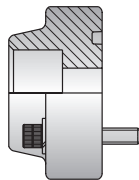

NOM. FLANGE SIZE	NOM. PIPE SIZE	DASH SIZE	TO SUIT PIPE OD	CODE 62 FLANGE SOCKET WELD PIPE	CODE 62 FLANGE FLAT SOCKET WELD PIPE UNC BOLT HOLES	CODE 62 FLANGE FLAT SOCKET WELD PIPE METRIC BOLT HOLES
inch	inch		mm	PART NO	PART NO	PART NO
3/4	3/4	-1212	26,7	S971-1212	S971F-1212	S971FM-1212
1	1	-1616	33,4	S971-1616	S971F-1616	S971FM-1616
1.1/4	1.1/4	-2020	42,2	S971-2020	S971F-2020	S971FM-2020
1.1/2	1.1/2	-2424	48,3	S971-2424	S971F-2424	S971FM-2424
2	2	-3232	60,3	S971-3232	S971F-3232	S971FM-3232

SAE FLANGE BLOCKS	S976	S976F	S977	S977F
-------------------	------	-------	------	-------

**BUTT WELD**  
**TO SUIT IMPERIAL PIPE**  
**O RING & BOLTS NOT SUPPLIED**

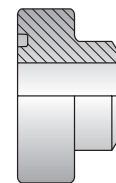
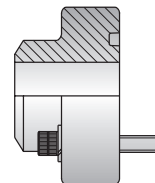
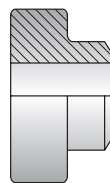
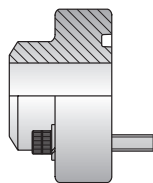

NOM. FLANGE SIZE	NOM. PIPE SIZE	DASH SIZE	TO SUIT PIPE OD	CODE 61 FLANGE BUTT WELD PIPE	CODE 61 FLANGE FLAT BUTT WELD PIPE UNC BOLT HOLES	CODE 62 FLANGE BUTT WELD PIPE	CODE 62 FLANGE FLAT BUTT WELD PIPE UNC BOLT HOLES
inch	inch		mm	PART NO	PART NO	PART NO	PART NO
1/2	1/2	-0808	21,3	S976-0808	S976F-0808	S977-0808	S977F-0808
3/4	3/4	-1212	26,7	S976-1212	S976F-1212	S977-1212	S977F-1212
1	1	-1616	33,4	S976-1616	S976F-1616	S977-1616	S977F-1616
1.1/4	1.1/4	-2020	42,2	S976-2020	S976F-2020	S977-2020	S977F-2020
1.1/2	1.1/2	-2424	48,3	S976-2424	S976F-2424	S977-2424	S977F-2424
2	2	-3232	60,3	S976-3232	S976F-3232	S977-3232	S977F-3232

**NOTE:** Bolts are shown for illustration purposes only. Bolts and O Ring are not included. See page 444 for Fastening Kits.

INTRODUCTION

ADAPTORS

COUPLINGS

ADAPTORS

TECHNICAL

SAE FLANGE BLOCKS	S951	S951F	S951FM
-------------------	------	-------	--------

**CODE 61**  
**BSPP FEMALE**  
**O RING & BOLTS NOT SUPPLIED**

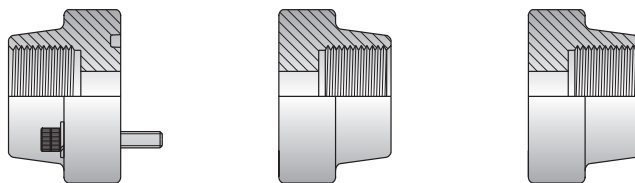

NOM. FLANGE SIZE	THREAD SIZE	DASH SIZE	CODE 61 FLANGE BSPP FEMALE	CODE 61 FLANGE FLAT BSPP FEMALE UNC BOLT HOLES	CODE 61 FLANGE FLAT BSPP FEMALE METRIC BOLT HOLES
inch	inch		PART NO	PART NO	PART NO
1/2	1/2	-0808	S951-0808	S951F-0808	S951FM-0808
3/4	3/4	-1212	S951-1212	S951F-1212	S951FM-1212
1	1	-1616	S951-1616	S951F-1616	S951FM-1616
1.1/4	1.1/4	-2020	S951-2020	S951F-2020	S951FM-2020
1.1/2	1.1/2	-2424	S951-2424	S951F-2424	S951FM-2424
2	2	-3232	S951-3232	S951F-3232	S951FM-3232

SAE FLANGE BLOCKS	S952	S952F	S952FM
-------------------	------	-------	--------

**CODE 62**  
**BSPP FEMALE**  
**O RING & BOLTS NOT SUPPLIED**

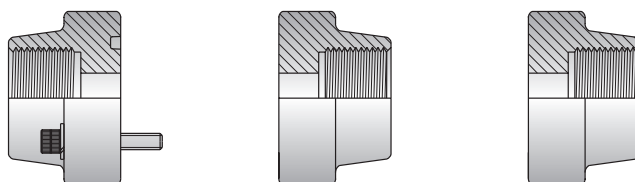

NOM. FLANGE SIZE	THREAD SIZE	DASH SIZE	CODE 62 FLANGE BSPP FEMALE	CODE 62 FLANGE FLAT BSPP FEMALE UNC BOLT HOLES	CODE 62 FLANGE FLAT BSPP FEMALE METRIC BOLT HOLES
inch	inch		PART NO	PART NO	PART NO
3/4	3/4	-1212	S952-1212	S952F-1212	S952FM-1212
1	1	-1616	S952-1616	S952F-1616	S952FM-1616
1.1/4	1.1/4	-2020	S952-2020	S952F-2020	S952FM-2020
1.1/2	1.1/2	-2424	S952-2424	S952F-2424	S952FM-2424
2	2	-3232	S952-3232	S952F-3232	S952FM-3232

SAE FLANGE BLOCKS	S953	S954
-------------------	------	------

**BSPP MALE**  
**O RING & BOLTS NOT SUPPLIED**

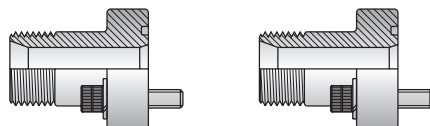

NOM. FLANGE SIZE	THREAD SIZE	DASH SIZE	CODE 61 FLANGE BSPP MALE	CODE 62 FLANGE BSPP MALE
inch	inch		PART NO	PART NO
1/2	1/2	-0808	S953-0808	S954-0808
3/4	3/4	-1212	S953-1212	S954-1212
1	1	-1616	S953-1616	S954-1616
1.1/4	1.1/4	-2020	S953-2020	S954-2020
1.1/2	1.1/2	-2424	S953-2424	S954-2424

**NOTE:** Bolts are shown for illustration purposes only. Bolts and O Ring are not included. See page 444 for Fastening Kits.

# ADAPTORS

## SAE FLANGE BLOCKS

SAE FLANGE BLOCKS	S957	S958
-------------------	------	------

JIC MALE  
O RING & BOLTS NOT SUPPLIED

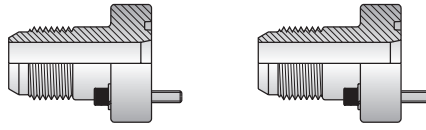

NOM. FLANGE SIZE	THREAD SIZE	DASH SIZE	CODE 61 FLANGE JIC MALE	CODE 62 FLANGE JIC MALE
inch	inch		PART NO	PART NO
1/2	3/4	-0812	S957-0812	S958-0812
3/4	1.1/16	-1217	S957-1217	S958-1217
1	1.5/16	-1621	S957-1621	S958-1621
1.1/4	1.5/8	-2026	S957-2026	S958-2026
1.1/2	1.7/8	-2430	S957-2430	S958-2430

**NOTE:** Bolts are shown for illustration purposes only. Bolts and O Ring are not included. See page 444 for Fastening Kits.

SWIVEL JOINT	S37	S36	SEAL KITS SJK
--------------	-----	-----	---------------

**BSP/BSP**  
**360° ROTATION**  
**10 RPM - NOT**  
**CONTINUOUS**  
**3000 PSI MAX**

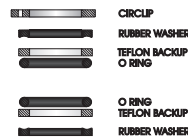
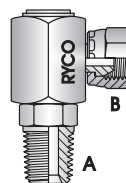
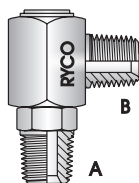

THREAD		DASH SIZE	BSPT MALE	BSPT MALE	REPLACEMENT SEAL KIT
A	B		BSPT MALE	BSPP FEMALE SWIVEL	
			90° SWIVEL JOINT	90° SWIVEL JOINTS	
inch	inch		PART NO	PART NO	PART NO
1/2	1/2	-0808	S37-0808	S36-0808	SJK-08
3/4	3/4	-1212	S37-1212	S36-1212	SJK-12

SWIVEL JOINT	S33	S34	S35	SEAL KITS SJK
--------------	-----	-----	-----	---------------

**JIC/JIC**  
**360° ROTATION**  
**10 RPM - NOT**  
**CONTINUOUS**  
**3000 PSI MAX**

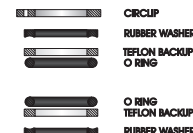
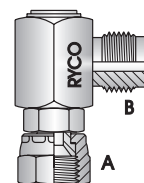
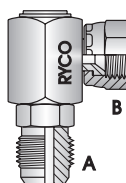
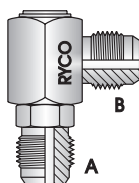

THREAD		DASH SIZE	JIC MALE	JIC MALE	JIC FEMALE	REPLACEMENT SEAL KIT
A	B		JIC MALE	JIC FEMALE	JIC MALE	
			90° SWIVEL JOINT	90° SWIVEL JOINT	90° SWIVEL JOINT	
inch	inch		PART NO	PART NO	PART NO	PART NO
7/8	7/8	-1414	S33-1414	S34-1414	S35-1414	SJK-08
1.1/16	1.1/16	-1717	S33-1717	S34-1717	S35-1717	SJK-12

SWIVEL JOINT	S131	SEAL KITS RKS
--------------	------	---------------

**JIC/JIC**  
**360° ROTATION**  
**20 RPM - NOT**  
**CONTINUOUS**  
**4000 PSI MAX**

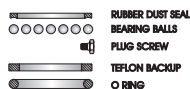

THREAD		DASH SIZE	JIC MALE	JIC FEMALE FIXED	REPLACEMENT SEAL KIT
A	B		JIC MALE	SWIVEL JOINT	
inch	inch		PART NO	PART NO	
1.1/16	1.1/16	-1717	S131-1717	RKS131-1717	
1.5/16	1.5/16	-2121	S131-2121	RKS131-2121	

**NOTE:** RYCO Swivel Joints are ideal for use wherever hose moves, bends or twists. They permit the use of less hose in flexing applications, producing neater space-saving installations and resulting in lower maintenance costs. Compact and lightweight, the RYCO Swivel Joint turns with very low torque under pressure, assuring fluid line flexibility and efficiency of operation.

Swivel Joints must not be used as high speed rotary unions, or as load bearing or structural components. They must be connected with a flexible hose on one end. External loads, e.g. the weight of the hose and couplings attached to the swivel joint; must be minimised to avoid premature wear and leakage.

**Operating Temperature Range:** From -40°C to + 100°C (-40°F to + 212°F).

**Fluid Compatibility:** Mineral / petroleum based hydraulic oils.

INTRODUCTION

ADAPTORS

COUPLINGS

ADAPTORS

TECHNICAL

# ADAPTORS

## UNO ADAPTORS

<b>UNO</b>	<b>S97</b>	<b>S97AK</b>
------------	------------	--------------

**PLUG  
O RING INCLUDED**

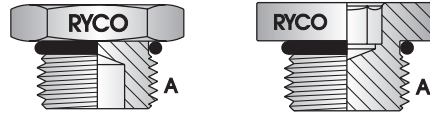

THREAD A	DASH SIZE	UN O RING MALE PLUG	UN O RING ALLEN KEY HEAD
inch		PART NO	PART NO
3/8	-06		<b>S97AK-06</b>
7/16	-07	<b>S97-07</b>	<b>S97AK-07</b>
1/2	-08	<b>S97-08</b>	<b>S97AK-08</b>
9/16	-09	<b>S97-09</b>	<b>S97AK-09</b>
3/4	-12	<b>S97-12</b>	<b>S97AK-12</b>
7/8	-14	<b>S97-14</b>	<b>S97AK-14</b>
1.1/16	-17	<b>S97-17</b>	<b>S97AK-17</b>
1.3/16	-19	<b>S97-19</b>	
1.5/16	-21	<b>S97-21</b>	
1.5/8	-26	<b>S97-26</b>	
1.7/8	-30	<b>S97-30</b>	

<b>UNO/UNO</b>	<b>S162</b>	<b>S163</b>
----------------	-------------	-------------

**STRAIGHT  
O RING INCLUDED**

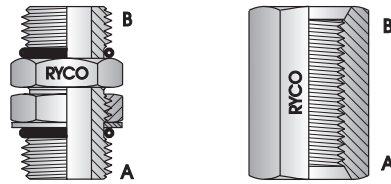

THREAD		DASH SIZE	UN O RING MALE ADJUSTABLE UN O RING MALE	UN O RING FEMALE SOCKET
A	B			
inch	inch		PART NO	PART NO
9/16	9/16	-0909		<b>S163-0909</b>
3/4	3/4	-1212	<b>S162-1212</b>	

<b>UNO</b>	<b>S148</b>
------------	-------------

**HALF SOCKET  
WELD ON**

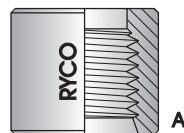

THREAD A	DASH SIZE	UN O RING FEMALE FIXED HALF WELD ON
inch		PART NO
9/16	-09	<b>S148-09</b>
3/4	-12	<b>S148-12</b>
7/8	-14	<b>S148-14</b>



## MISCELLANEOUS - O RINGS

<b>O RINGS</b>	<b>ROD-AC</b> SUIT AIR CON	<b>ROD-FS</b> SUIT ORFS
----------------	-------------------------------	----------------------------

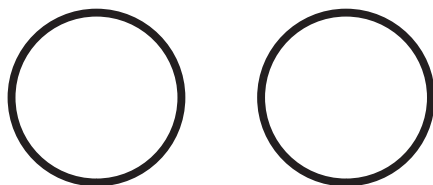

THREAD SIZE	TUBE SIZE	70 DUROMETER (GREEN HNBR)		90 DUROMETER	
inch	inch	PART NO	Pack Qty	PART NO	Pack Qty
9/16	1/4			ROD-FS09	10
5/8	3/8	ROD-AC10	10		
11/16	3/8			ROD-FS11	10
3/4	1/2	ROD-AC12	10		
13/16	1/2			ROD-FS13	10
7/8	5/8	ROD-AC14	10		
1	5/8			ROD-FS16	10
1.3/16	3/4			ROD-FS19	10
1.7/16	1			ROD-FS23	10
1.11/16	1.1/4			ROD-FS27	10
2	1.1/2			ROD-FS32	10

<b>O RINGS</b>	<b>ROD-BP</b> SUIT BSPP
----------------	----------------------------

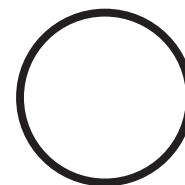

THREAD SIZE	90 DUROMETER	
inch	PART NO	Pack Qty
1/8	ROD-BP02	10
1/4	ROD-BP04	10
3/8	ROD-BP06	10
1/2	ROD-BP08	10
5/8	ROD-BP10	10
3/4	ROD-BP12	10
1	ROD-BP16	10
1.1/4	ROD-BP20	10
1.1/2	ROD-BP24	10
2	ROD-BP32	10

INTRODUCTION

ADAPTORS

COUPLINGS

<b>O RINGS</b>	<b>ROD-DL</b> SUIT DKOL FEMALE METRIC
----------------	---

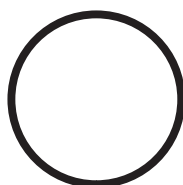

THREAD SIZE	TUBE SIZE	70 DUROMETER	
mm	mm	PART NO	Pack Qty
12x1,5	6	ROD-DL12	10
14x1,5	8	ROD-DL14	10
16x1,5	10	ROD-DL16	10
18x1,5	12	ROD-DL18	10
22x1,5	15	ROD-DL22	10
26x1,5	18	ROD-DL26	10
30x2,0	22	ROD-DL30	10
36x2,0	28	ROD-DL36	10
45x2,0	35	ROD-DL45	10
52x2,0	42	ROD-DL52	

<b>O RINGS</b>	<b>ROD-DS</b> SUIT DKOS FEMALE METRIC
----------------	---

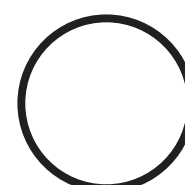

THREAD SIZE	TUBE SIZE	70 DUROMETER	
mm	mm	PART NO	Pack Qty
14x1,5	6	ROD-DS14	10
16x1,5	8	ROD-DS16	10
18x1,5	10	ROD-DS18	10
20x1,5	12	ROD-DS20	10
22x1,5	14	ROD-DS22	10
24x1,5	16	ROD-DS24	10
30x2,0	20	ROD-DS30	10
36x2,0	25	ROD-DS36	10
42x2,0	30	ROD-DS42	10
52x2,0	38	ROD-DS52	10

ADAPTORS

TECHNICAL

**NOTE:** O Rings/Seals are sold only in packs of 10. Part Number Series for individual seal is RO. Example: Order Part No RO-BP02 for individual seal. (D is removed from ROD). Surcharges for breaking packages may apply.

# ADAPTORS

## MISCELLANEOUS - O RINGS

<b>O RINGS</b>	<b>ROD-SF</b> SUIT SAE <b>FLANGE</b>
----------------	--

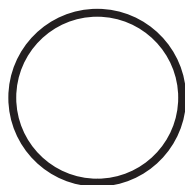

NOMINAL FLANGE SIZE	90 DUROMETER	
inch	PART NO	Pack Qty
1/2	ROD-SF08	10
5/8	ROD-SF10	10
3/4	ROD-SF12	10
1	ROD-SF16	10
1.1/4	ROD-SF20	10
1.1/2	ROD-SF24	10
2	ROD-SF32	10
2.1/2	ROD-SF40	10

<b>O RINGS</b>	<b>ROD-UN</b> SUIT UNO
----------------	---------------------------

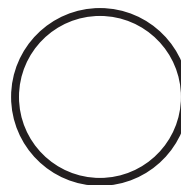

NOM FLANGE SIZE	TUBE SIZE	90 DUROMETER	
inch	inch	PART NO	Pack Qty
7/16	1/4	ROD-UN07	10
1/2	5/16	ROD-UN08	10
9/16	3/8	ROD-UN09	10
3/4	1/2	ROD-UN12	10
7/8	5/8	ROD-UN14	10
1.1/16	3/4	ROD-UN17	10
1.3/16	7/8	ROD-UN19	10
1.5/16	1	ROD-UN21	10
1.5/8	1.1/4	ROD-UN26	10
1.7/8	1.1/2	ROD-UN30	10

<b>SEALS</b>	<b>ROD-WD/ROD-BE</b> SUIT BSPP <b>ENCAPSULATED</b> <b>MALE</b>
--------------	---



THREAD SIZE	90 DUROMETER	
inch	PART NO	Pack Qty
1/8	ROD-WD084	10
1/4	ROD-WD116	10
3/8	ROD-WD147	10
1/2	ROD-WD185	10
3/4	ROD-WD239	10
1	ROD-WD297	10
1.1/4	ROD-WD388	10
1.1/2	ROD-WD447	10
2	ROD-BE32*	10

\*NOTE: Seal is a circular cross-section.

**NOTE:** O Rings/Seals are sold only in packs of 10. Part Number Series for individual seal is RO. Example: Order Part No RO-BP02 for individual seal. (D is removed from ROD). Surcharges for breaking packages may apply.

## MISCELLANEOUS - PLASTIC CAPS AND PLUGS

<b>BSP/NPT</b>	<b>BPD</b>	<b>BCD</b>
----------------	------------	------------

**THREADED  
PLASTIC  
PROTECTORS**

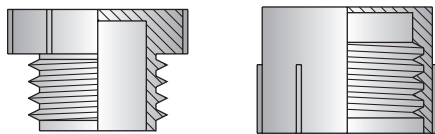

THREAD SIZE	PACK QTY	PLUG SUITS FEMALE BSP & NPSM	CAP SUITS MALE BSP & NPT
inch		PART NO	PART NO
1/8	100	<b>BPD-02</b>	<b>BCD-02</b>
1/4	100	<b>BPD-04</b>	<b>BCD-04</b>
3/8	100	<b>BPD-06</b>	<b>BCD-06</b>
1/2	100	<b>BPD-08</b>	<b>BCD-08</b>
3/4	100	<b>BPD-12</b>	<b>BCD-12</b>
1	100	<b>BPD-16</b>	<b>BCD-16</b>
1.1/4	10	<b>BPD-20</b>	<b>BCD-20</b>
1.1/2	10	<b>BPD-24</b>	<b>BCD-24</b>
2	10	<b>BPD-32</b>	<b>BCD-32</b>

<b>JIC/SAE/UNO</b>	<b>JPPD</b>	<b>JPD</b>	<b>JCD</b>	<b>JCTD</b>
--------------------	-------------	------------	------------	-------------

**THREADED  
PLASTIC PROTECTORS**

**TEAR OFF PLASTIC  
THREAD PROTECTOR**

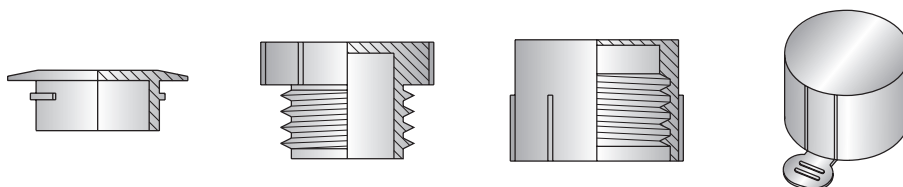

THREAD SIZE	PACK QTY	PUSH-IN PLUG SUITS FEMALE JIC, SAE & UNO	PLUG SUITS FEMALE JIC, SAE & UNO	CAP SUITS MALE JIC, SAE & UNO	TEAR OFF CAP SUITS MALE JIC, SAE & UNO
		PART NO	PART NO	PART NO	PART NO
7/16-20	100	<b>JPPD-07</b>	<b>JPD-07</b>	<b>JCD-07</b>	<b>JCTD-07</b>
1/2-20	100		<b>JPD-08</b>	<b>JCD-08</b>	
9/16-18	100	<b>JPPD-09</b>	<b>JPD-09</b>	<b>JCD-09</b>	<b>JCTD-09</b>
5/8-18	100		<b>JPD-10</b>	<b>JCD-10</b>	
3/4-16	100	<b>JPPD-12</b>	<b>JPD-12</b>	<b>JCD-12</b>	<b>JCTD-12</b>
7/8-14	100	<b>JPPD-14</b>	<b>JPD-14</b>	<b>JCD-14</b>	<b>JCTD-14</b>
1.1/16-12	100	<b>JPPD-17</b>	<b>JPD-17</b>	<b>JCD-17</b>	<b>JCTD-17</b>
1.3/16-12	100		<b>JPD-19</b>	<b>JCD-19</b>	
1.5/16-12	100		<b>JPD-21</b>	<b>JCD-21</b>	<b>JCTD-21</b>
1.5/8-12	10		<b>JPD-26</b>	<b>JCD-26</b>	<b>JCTD-26</b>
1.7/8-12	10				<b>JCTD-30</b>

**NOTE:** Plastic Thread Protectors are sold only in packs with quantities as shown. To order individual Plastic Thread Protectors, remove the "D" preceding the part number dash. Example: Order Part No BP-02 for individual part ("D" is removed from BPD-02 packaged Part No). Surcharges for breaking packages may apply.

Part Numbers for Plastic Caps and Plugs: First letter denotes Thread Type, **B = BSP**, **O = ORFS** etc. Second letter denotes Plug or Cap, **P = Plug**, **C = Cap**. A "D" before the dash represents the packaged part number (omit for unpackaged, individual Plug or Cap). Numbers after the dash represent the Thread Size or Dash Size of the Plug or Cap.

INTRODUCTION

ADAPTORS

COUPLINGS

ADAPTORS

TECHNICAL

# ADAPTORS

## MISCELLANEOUS - PLASTIC CAPS AND PLUGS

METRIC	MPD	MCD
--------	-----	-----

THREADED  
PLASTIC  
PROTECTORS

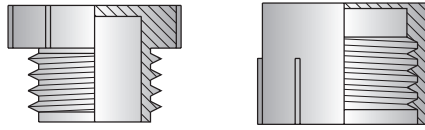

THREAD SIZE	PACK QTY	PLUG SUITS FEMALE METRIC	CAP SUITS MALE METRIC
mm		PART NO	PART NO
12x1,5	100	MPD-1215	MCD-1215
14x1,5	100	MPD-1415	MCD-1415
16x1,5	100	MPD-1615	MCD-1615
18x1,5	100	MPD-1815	MCD-1815
20x1,5	100	MPD-2015	MCD-2015
22x1,5	100	MPD-2215	MCD-2215
24x1,5	100	MPD-2415	MCD-2415
26x1,5	100	MPD-2615	MCD-2615
30x1,5	10	MPD-3015	
30x2,0	10	MPD-3020	MCD-3020
36x2,0	10	MPD-3620	MCD-3620
42x2,0	10	MPD-4220	MCD-4220
45x2,0	10	MPD-4250	MCD-4250
52x2,0	10	MPD-5220	MCD-5220

ORFS	OPD	OCD
------	-----	-----

THREADED  
PLASTIC  
PROTECTORS

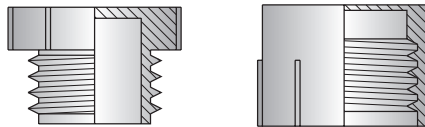

THREAD SIZE	PACK QTY	PLUG SUITS FEMALE ORFS	CAP SUITS MALE ORFS
inch		PART NO	PART NO
9/16	100	USE JPD-09	USE JCD-09
11/16	100	OPD-11	OCD-11
13/16	100	OPD-13	OCD-13
1	100	OPD-16	OCD-16
1.3/16	100	USE JPD-19	USE JCD-19
1.7/16	100	OPD-23	OCD-23
1.11/16	10		OCD-27

**NOTE:** Plastic Thread Protectors are sold only in packs with quantities as shown. To order individual Plastic Thread Protectors, remove the "D" preceding the part number dash. Example: Order Part No BP-02 for individual part ("D" is removed from BPD-02 packaged Part No). Surcharges for breaking packages may apply.

Part Numbers for Plastic Caps and Plugs: First letter denotes Thread Type, **B = BSP**, **O = ORFS** etc. Second letter denotes Plug or Cap, **P = Plug**, **C = Cap**. A "D" before the dash represents the packaged part number (omit for unpackaged, individual Plug or Cap). Numbers after the dash represent the Thread Size or Dash Size of the Plug or Cap.

## MISCELLANEOUS - PLASTIC CAPS AND PLUGS

<b>SAE FLANGE</b>	<b>FC61D</b>	<b>FC62D</b>	<b>R62C TYPE</b>
-------------------	--------------	--------------	------------------

**FLANGE COVERS  
PLASTIC  
CODE 61  
CODE 62  
R62C TYPE**

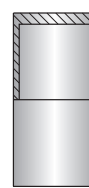
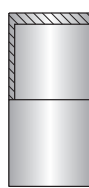
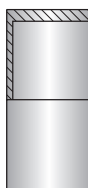

NOM. FLANGE SIZE	PACK QTY	SUITS SAE CODE 61 FLANGE	SUITS SAE CODE 62 FLANGE	SUITS R62C FLANGE
		<b>PART NO</b>	<b>PART NO</b>	<b>PART NO</b>
1/2	100	<b>FC61D-08</b>	<b>FC62D-08</b>	
3/4	100	<b>FC61D-12</b>	<b>FC62D-12</b>	<b>USE FC62D-12</b>
1	100	<b>FC61D-16</b>	<b>FC62D-16</b>	<b>USE FC62D-16</b>
1.1/4	10	<b>FC61D-20</b>	<b>FC62D-20</b>	<b>USE FC62D-20</b>
1.1/2	10	<b>FC61D-24</b>	<b>FC62D-24</b>	<b>USE FC62D-24</b>
2	10	<b>FC61D-32</b>	<b>FC62D-32</b>	

<b>800 SERIES</b>	<b>PPD</b>
-------------------	------------

**PUSH ON  
HOSE TAIL  
PLASTIC COLLAR**



HOSE SIZE	PACK QTY	SUITS 800 SERIES FITTING
1/4	100	<b>PPD-04</b>
5/16	100	<b>PPD-05</b>
3/8	100	<b>PPD-06</b>
1/2	100	<b>PPD-08</b>
5/8	100	<b>PPD-10</b>
3/4	100	<b>PPD-12</b>

**NOTE:** Plastic Thread Protectors are sold only in packs with quantities as shown. To order individual Plastic Thread Protectors, remove the "D" preceding the part number dash. Example: Order Part No BP-02 for individual part ("D" is removed from BPD-02 packaged Part No). Surcharges for breaking packages may apply.

Part Numbers for Plastic Caps and Plugs: First letter denotes Thread Type, **B = BSP**, **O = ORFS** etc. Second letter denotes Plug or Cap, **P = Plug**, **C = Cap**. A "D" before the dash represents the packaged part number (omit for unpackaged, individual Plug or Cap). Numbers after the dash represent the Thread Size or Dash Size of the Plug or Cap.

INTRODUCTION

ADAPTORS

COUPLINGS

ADAPTORS

TECHNICAL

# ADAPTORS

## MISCELLANEOUS - TUBE BENDS

TUBE BENDS	14	15	25	25HL
------------	----	----	----	------

IMPERIAL  
OUTSIDE  
DIAMETER

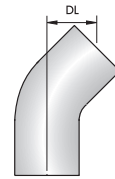
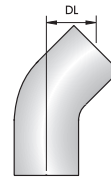
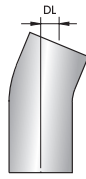

TUBE SIZE	DASH SIZE	22.5° TUBE BEND		30° TUBE BEND		45° TUBE BEND		45° TUBE BEND HEAVY	
inch		PART NO	DL	PART NO	DL	PART NO	DL	PART NO	DL
1/4	-04					25-04	8		
3/8	-06					25-06	10		
1/2	-08					25-08	11		
5/8	-10					25-10	12		
3/4	-12	14-12	7	15-12	8	25-12	14	25HL-12	14
1	-16	14-16	8	15-16	9	25-16	17	25HL-16	17
1.1/4	-20	14-20	9	15-20	10	25-20	20	25HL-20	20
1.1/2	-24	14-24	12	15-24	10	25-24	23	25HL-24	23
2	-32	14-32	17			25-32	30	25HL-32	30

**NOTE:** Tube Bends can be used in conjunction with S112 Tube Joiners shown on page 431, when a tube bender is not available, or tighter bends than can be achieved by bending hydraulic tube are required. Drop Lengths (DL) dimensions are in millimetres.

TUBE BENDS	17	16
------------	----	----

IMPERIAL  
OUTSIDE  
DIAMETER

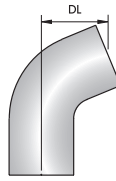
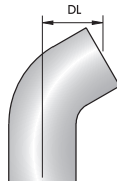

TUBE SIZE	DASH SIZE	60° TUBE BEND		67.5° TUBE BEND	
inch		PART NO	DL	PART NO	DL
3/4	-12	17-12	26	16-12	30
1	-16	17-16	31	16-16	36
1.1/4	-20	17-20	35	16-20	42
1.1/2	-24	17-24	45	16-24	53
2	-32	17-32	65	16-32	75

**NOTE:** Tube Bends can be used in conjunction with S112 Tube Joiners shown on page 431, when a tube bender is not available, or tighter bends than can be achieved by bending hydraulic tube are required. Drop Lengths (DL) dimensions are in millimetres.

<b>TUBE BENDS</b>	<b>24A</b>	<b>24B</b>
-------------------	------------	------------

IMPERIAL  
OUTSIDE  
DIAMETER

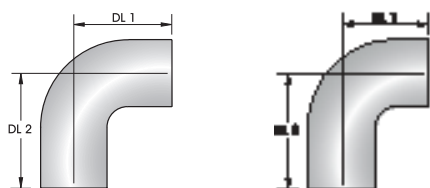

TUBE BEND	DASH SIZE	90° SPECIAL LONG TUBE BEND			90° SPECIAL LONG TUBE BEND		
inch		PART NO	DL1	DL2	PART NO	DL1	DL2
5/8	-10	<b>24A-10</b>	37	64			
3/4	-12	<b>24A-12</b>	42	66	<b>24B-12</b>	42	84
1.1/4	-20	<b>24A-20</b>	61	68	<b>24B-20</b>	61	80
1.1/2	-24	<b>24A-24</b>	77	101	<b>24B-24</b>	77	137
2	-32	<b>24A-32</b>	107	153			

**NOTE:** Tube Bends can be used in conjunction with S112 Tube Joiners shown on page 431, when a tube bender is not available, or tighter bends than can be achieved by bending hydraulic tube are required. Drop Lengths (DL) dimensions are in millimetres.

<b>TUBE BENDS</b>	<b>24</b>	<b>24HL</b>	<b>21</b>	<b>91</b>
-------------------	-----------	-------------	-----------	-----------

IMPERIAL  
OUTSIDE  
DIAMETER

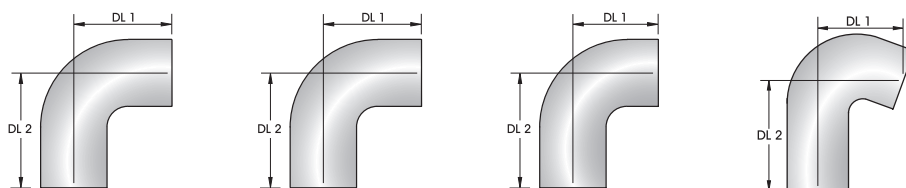

TUBE BEND	DASH SIZE	90° TUBE BEND			90° TUBE BEND HEAVY			90° LONG TUBE BEND			110° LONG TUBE BEND		
inch		PART NO	DL1	DL2	PART NO	DL1	DL2	PART NO	DL1	DL2	PART NO	DL1	DL2
1/4	-04	<b>24-04</b>	17	17				<b>21-04</b>	17	38			
3/8	-06	<b>24-06</b>	22	22				<b>21-06</b>	22	48			
1/2	-08	<b>24-08</b>	27	27				<b>21-08</b>	27	54			
5/8	-10	<b>24-10</b>	31	31				<b>21-10</b>	31	59			
3/4	-12	<b>24-12</b>	36	36	<b>24HL-12</b>	36	36	<b>21-12</b>	36	67			
1	-16	<b>24-16</b>	47	47	<b>24HL-16</b>	47	47	<b>21-16</b>	47	81			
1.1/4	-20	<b>24-20</b>	57	57	<b>24HL-20</b>	57	57	<b>21-20</b>	57	97			
1.1/2	-24	<b>24-24</b>	66	66	<b>24HL-24</b>	66	66	<b>21-24</b>	67	114	<b>91-24</b>	95	127
2	-32	<b>24-32</b>	86	86	<b>24HL-32</b>	86	86				<b>91-32</b>	131	141

**NOTE:** Tube Bends can be used in conjunction with S112 Tube Joiners shown on page 431, when a tube bender is not available, or tighter bends than can be achieved by bending hydraulic tube are required. Drop Lengths (DL) dimensions are in millimetres.

INTRODUCTION

ADAPTORS

COUPLINGS

ADAPTORS

TECHNICAL



# ADAPTORS

## RYCO WEO ADAPTORS

<b>RYCO WEO</b>	<b>RW723</b>	<b>RW811</b>
-----------------	--------------	--------------

**PLUG  
CAP**

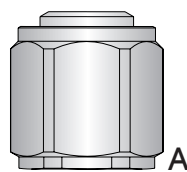
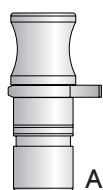

RYCO WEO SIZE A		DASH SIZE	RYCO WEO MALE STOP PLUG	RYCO WEO FEMALE STOP CAP
DN	inch		PART NO	PART NO
6	1/4	-04	RW723-04	RW811-04
10	3/8	-06	RW723-06	RW811-06
12	1/2	-08	RW723-08	RW811-08
19	3/4	-12	RW723-12	RW811-12
25	1	-16	RW723-16	RW811-16

<b>RYCO WEO</b>	<b>RW722</b>
-----------------	--------------

**STRAIGHT**

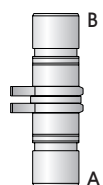

RYCO WEO SIZE A, B		DASH SIZE	RYCO WEO MALE NIPPLE
DN	inch		PART NO
6	1/4	-0404	RW722-0404
10	3/8	-0606	RW722-0606
12	1/2	-0808	RW722-0808
19	3/4	-1212	RW722-1212
25	1	-1616	RW722-1616

<b>RYCO WEO</b>	<b>RW813</b>
-----------------	--------------

**FEMALE BULKHEAD**

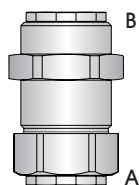

RYCO WEO SIZE A, B		THREAD A, B	DASH SIZE	RYCO WEO FEMALE BULKHEAD
DN	inch	inch		PART NO
6	1/4	M21,5x1,5	-0404	RW813-0404
10	3/8	M26x1,5	-0606	RW813-0606
12	1/2	M30x2,0	-0808	RW813-0808

**NOTE:** RYCO WEO male and female couplings and adaptors do not contain a shut-off valve. When not in use, cap the RYCO WEO male using the appropriate size RW811 series stop cap and plug the RYCO WEO female/cartridge using the appropriate size RW723 series stop plug.

<b>RYCO WEO/BSPP</b>	<b>RW721</b>	<b>RW830</b>	<b>RW860</b>
----------------------	--------------	--------------	--------------

STRAIGHT

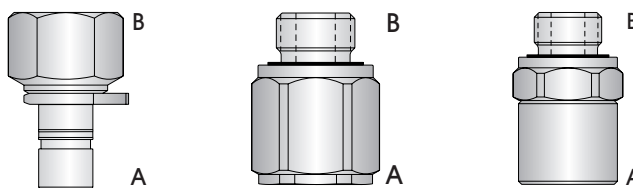

RYCO WEO SIZE A		THREAD SIZE B	DASH SIZE	RYCO WEO MALE BSPP FEMALE	RYCO WEO FEMALE BSPP ENCAPSULATED MALE	RYCO WEO FEMALE SWIVEL BSPP ENCAPSULATED MALE
DN	inch	inch		PART NO	PART NO	PART NO
6	1/4	1/4	-0404		RW830-0404	
10	3/8	3/8	-0606	RW721-0606	RW830-0606	RW860-0606
12	1/2	1/2	-0808	RW721-0808	RW830-0808	RW860-0808
19	3/4	3/8	-1212	RW721-1212	RW830-1212	RW860-1212
25	1	1	-1616		RW830-1616	

<b>RYCO WEO/JIC</b>	<b>RW727</b>	<b>RW824</b>
---------------------	--------------	--------------

STRAIGHT

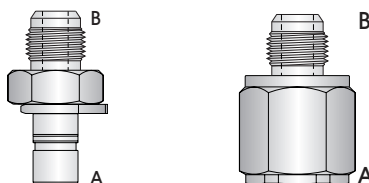

RYCO WEO SIZE A		THREAD SIZE B	DASH SIZE	RYCO WEO MALE JIC MALE	RYCO WEO FEMALE JIC MALE
DN	inch	inch		PART NO	PART NO
6	1/4	7/16	-0407	RW727-0407	RW824-0407
10	3/8	9/16	-0609	RW727-0609	RW824-0609
12	1/2	3/4	-0812	RW727-0812	RW824-0812
12	1/2	7/8	-0814		RW824-0814
12	1/2	1.1/16	-0817		RW824-0817
19	3/4	1.1/16	-1217	RW727-1217	RW824-1217

<b>RYCO WEO/METRIC</b>	<b>RW725</b>	<b>RW822</b>
------------------------	--------------	--------------

STRAIGHT

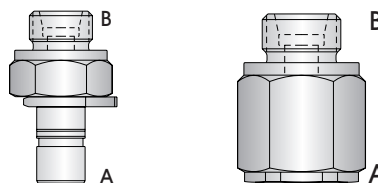

RYCO WEO SIZE A		THREAD SIZE B	TUBE OD	DASH SIZE	RYCO WEO MALE DKL MALE	RYCO WEO FEMALE DKL MALE
DN	inch	inch	mm		PART NO	PART NO
6	1/4	M14x1,5	8	-0414	RW725-0414	RW822-0414
10	3/8	M18x1,5	12	-0618	RW725-0618	RW822-0618
12	1/2	M22x1,5	15	-0822	RW725-0822	RW822-0822
19	3/4	M30x2,0	22	-1230	RW725-1230	RW822-1230

**NOTE:** RYCO WEO male and female couplings and adaptors do not contain a shut-off valve. When not in use, cap the RYCO WEO male using the appropriate size RW811 series stop cap and plug the RYCO WEO female/cartridge using the appropriate size RW723 series stop plug.

# ADAPTORS

## RYCO WEO ADAPTORS

<b>RYCO WEO/METRIC</b>	<b>RW726</b>	<b>RW823</b>
------------------------	--------------	--------------

**STRAIGHT**

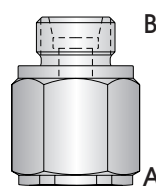
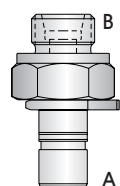

RYCO WEO SIZE A		THREAD SIZE B		TUBE OD	DASH SIZE	RYCO WEO MALE DKS MALE	RYCO WEO FEMALE DKS MALE
DN	inch	inch	mm			PART NO	PART NO
6	1/4	M16x1,5	8		-0416	RW726-0416	RW823-0416
10	3/8	M20x1,5	12		-0620	RW726-0620	RW823-0620
12	1/2	M24x1,5	16		-0824	RW726-0824	RW823-0824
19	3/4	M36x2,0	25		-1236	RW726-1236	RW823-1236

<b>RYCO WEO/METRIC O RING BOSS</b>	<b>RW831</b>
------------------------------------	--------------

**STRAIGHT**

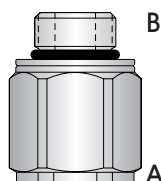

RYCO WEO SIZE A		THREAD SIZE B		DASH SIZE	RYCO WEO MALE METRIC MALE O RING BOSS
DN	inch	inch			PART NO
10	3/8	M12x1,5		-06	RW831-0612
10	3/8	M16x1,5		-06	RW831-0616
12	1/2	M18x1,5		-08	RW831-0818
19	3/4	M22x1,5		-12	RW831-1222
19	3/4	M27x2,0		-12	RW831-1227

<b>RYCO WEO/UNO</b>	<b>RW826</b>
---------------------	--------------

**STRAIGHT**

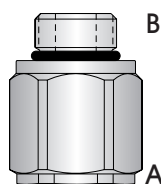

RYCO WEO SIZE A		THREAD SIZE B		DASH SIZE	RYCO WEO FEMALE UN O RING MALE
DN	inch	inch			PART NO
6	1/4	7/16		-0407	RW826-0407
10	3/8	9/16		-0609	RW826-0609
12	1/2	3/4		-0812	RW826-0812
12	1/2	7/8		-0814	RW826-0814
12	1/2	1.1/16		-0817	RW826-0817
19	3/4	1.1/16		-1217	RW826-1217
25	1	1.5/16		-1621	RW826-1621

**NOTE:** RYCO WEO male and female couplings and adaptors do not contain a shut-off valve. When not in use, cap the RYCO WEO male using the appropriate size RW811 series stop cap and plug the RYCO WEO female/cartridge using the appropriate size RW723 series stop plug.

**BSP BANJO BOLT      BBB**

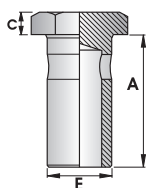

THREAD SIZE E	DIMENSIONS (MM)			BSP BANJO BOLT
	A	C	A/F	
inch				PART NO
G1/4"-19	28,5	6,0	19	<b>BBB-04</b>
G3/8"-19	38,5	7,0	22	<b>BBB-06</b>
G1/2"-14	44,0	8,5	27	<b>BBB-08</b>
G5/8"-14	48,5	10,0	30	<b>BBB-10</b>
G3/4"-14	56,0	10,0	32	<b>BBB-12</b>
G1"-11	68,5	13,0	41	<b>BBB-16</b>

**NOTE: RL21D** Seals for BBB Banjo Bolts can be found on page 404.

**METRIC BANJO BOLT      BBM**

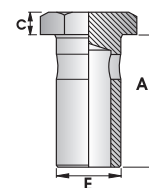

THREAD SIZE E	DIMENSIONS (MM)			METRIC BANJO BOLT
	A	C	A/F	
mm				PART NO
M10x1,0	19	6	14	<b>BBM-10</b>
M12x1,5	24	6	17	<b>BBM-12</b>
M14x1,5	26	6	19	<b>BBM-14</b>
M16x1,5	28	6	22	<b>BBM-16</b>
M18x1,5	32	6	24	<b>BBM-18</b>
M20x1,5	37	7	27	<b>BBM-20</b>
M22x1,5	39	7	27	<b>BBM-22</b>
M26x1,5	45	7	32	<b>BBM-26</b>
M30x1,5	51	7	36	<b>BBM-30</b>
M36x2,0	71	12	46	<b>BBM-36</b>

**NOTE: MBD** Seals for BBM Banjo Bolts can be found on page 432.

**BSPP BALL VALVE      RL20SH**

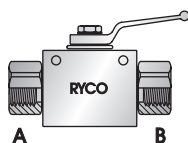

THREAD SIZE		DASH SIZE	MAX. WORKING PRESSURE		BALL VALVE BSPP FEMALE BSPP FEMALE
A	B		bar	psi	
inch	inch				PART NO
1/4	1/4	-0404	500	7250	<b>RL20SH-0404</b>
3/8	3/8	-0606	500	7250	<b>RL20SH-0606</b>
1/2	1/2	-0808	500	7250	<b>RL20SH-0808</b>
3/4	3/4	-1212	400	5800	<b>RL20SH-1212</b>
1	1	-1616	350	5100	<b>RL20SH-1616</b>
1.1/4	1.1/4	-2020	350	5100	<b>RL20SH-2020</b>
1.1/2	1.1/2	-2424	350	5100	<b>RL20SH-2424</b>
2	2	-3232	350	5100	<b>RL20SH-3232</b>

INTRODUCTION

ADAPTORS

COUPLINGS

ADAPTORS

TECHNICAL

TECHNICAL



PAGE	SECTION
<b>464 to 468</b>	<b>HOSE SELECTION AND HOSE ASSEMBLIES</b>
464	Hose Selection Nomograph
465	How to Order Hose Assemblies
466	How to Order Hose Assemblies & Cut-Off Allowance (CA)
467 to 405	Hose Selection
<b>469 to 471</b>	<b>SAFETY</b>
<b>469 to 471</b>	Safety Guide
472	Safety Guide – Maximum Temperature Limits
474	Characteristics of Hose Elastomers
475	Chemical Compatibility for Hose
<b>476 to 492</b>	<b>HOSE ASSEMBLY GUIDES</b>
476	Field Attachable Non-Skive Hose Assembly
477	Field Attachable Skive Hose Assembly
478	Non-Skive Hose Assembly
479	Skive Hose Assembly
480	Assembly Instructions – RTH1 Hoses
481	Assembly Instructions – SRX & SRF Hoses
482	Assembly Instructions – PL1, PL1D , PL1PV & RQP6 Hoses
483	Assembly Instructions – TP7T, TP7TN, TP8T and TP8TN Twin Hose
484 to 485	Tube Flaring Dimensions – 37° JIC and 45° SAE
486 to 487	Assembly Instructions – Tube Bite Hose Couplings (End Style 850)
488 to 489	Assembly Instructions – S134 J-LOK Flareless Tube Fittings
490 to 492	Hose Assembly – Installation Guide
493	Factor Of Safety - Hose Assemblies
<b>494 to 498</b>	<b>THREAD AND CONNECTOR DATA</b>
494 to 498	Guide to Thread and Connector Working Pressures
499	Important Note regarding Thread Dash Size/Tube Dash Size
500 to 512	Thread and Connector Identification
<b>513 to 514</b>	<b>TORQUE ASSEMBLY VALUES</b>
515	Abbreviations

INTRODUCTION

HOSE

COUPLINGS

ADAPTORS

TECHNICAL



# HOSE SIZE SELECTION NOMOGRAPH

## INDICATING FLOW CAPACITY OF HOSE ASSEMBLIES AT RECOMMENDED FLOW VELOCITIES SELECTING THE RIGHT HOSE SIZE

With this nomograph, you can easily select the correct Hose ID size, Desired Flow Rate and Recommended Flow Velocity. If any two of these factors are known, the third can be determined.

### TO USE THIS NOMOGRAPH:

1. Pick the two known values.
2. Lay a straightedge to intersect the two values.
3. Intersection on the third vertical line gives the value of that factor.

**Example:** To find the bore size for a Pressure Line consistent with a Flow Rate of 100 litres per minute (26 US or 22 Imperial gallons per minute), and a Flow Velocity of 4,5 metres per second (14.8 feet per second), connect Flow Rate to Flow Velocity and read Hose Bore on centre scale.

**ANSWER: THE LINE CROSSES HOSE BORE BETWEEN -12 AND -16 ON "ALL OTHER DASH SIZES" SIDE OF HOSE BORE AXIS, SO A -16 HOSE IS REQUIRED. IF RQP5 OR T5 HOSE IS TO BE USED, FOR THIS EXAMPLE -16 WOULD ALSO BE REQUIRED.**

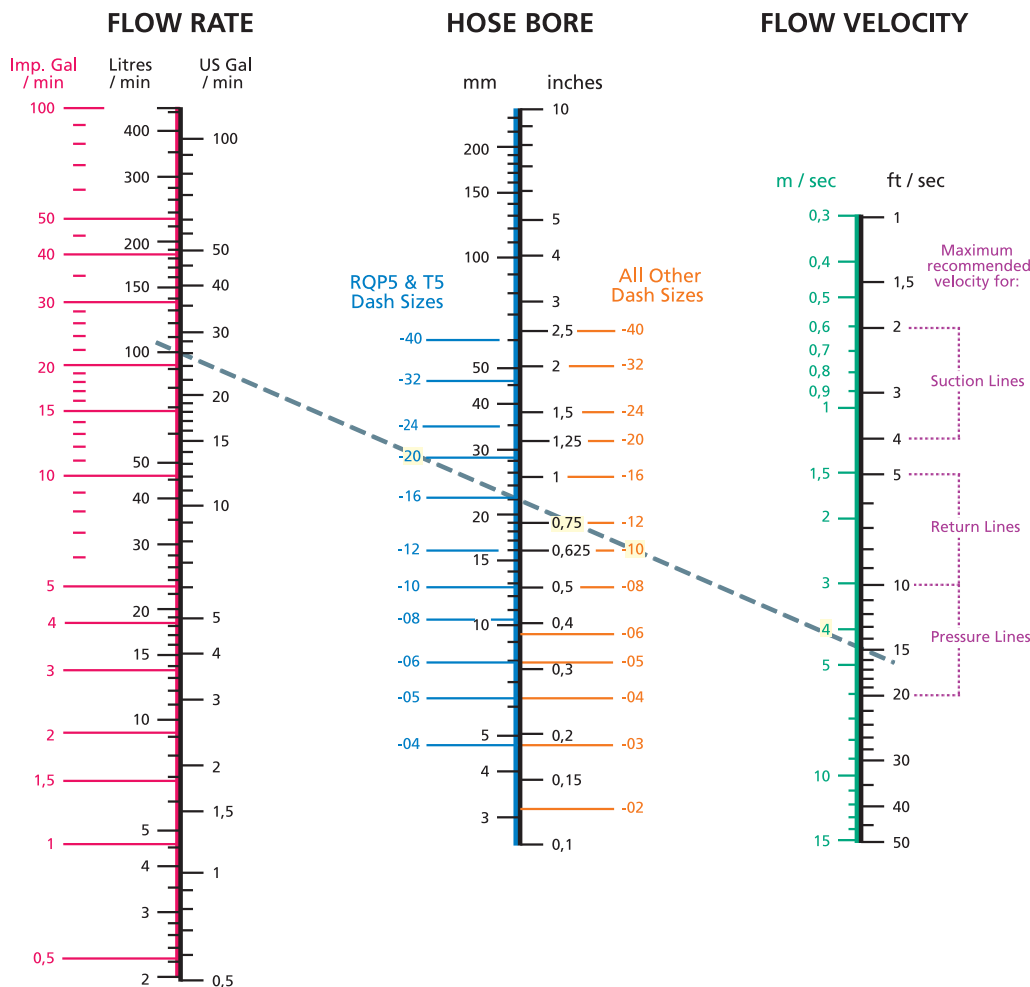

The velocity of the fluid should not exceed the range shown in the right hand column. When oil velocities are higher than recommended in the chart, turbulent flow occurs, resulting in loss of pressure and excessive heating. For long hoses and/or high viscosity oil, or if the flow of hydraulic fluid is continuous, it is recommended to use figures at the lower end of the Maximum Recommended Velocity range. For short hoses and/or low viscosity oil, or if the flow of hydraulic fluid is intermittent or for only short periods of time, figures at the higher end of the Maximum Recommended Velocity range can be used.

### A FURTHER EXAMPLE WILL HELP YOU TO USE THIS CHART:

Determine the hose size required to carry 40 litres of oil per minute and determine the velocity of the oil through the hose assembly. The assembly is to be used as a pressure line and the flow will be continuous.

Locate the flow, 40 litres per minute (left hand column), and velocity, 15 feet per second (right hand column), since 15 is the centre of the Pressure Lines Maximum recommended velocity range. Lay a straight edge across these two points.

The straight edge crosses the centre column just above the -08 on "All Other Dash Sizes" side of Hose Bore axis. Keeping the straight edge on 40 litres per minute, cross the centre column at -08 and -10 sizes and read the Flow Velocity in the right hand column. It can be seen that using -08 Hose Size, Flow Velocity will be 18 feet per second, and for -10 Hose Size, Flow Velocity will be 11 feet per second. As the flow is continuous, -10 Hose Size is recommended.



## HOSE ASSEMBLIES OF SPECIFIC LENGTHS

All RYCO hose assemblies are manufactured seat to seat length unless otherwise specified by customer. The length of a Hose Assembly can be measured in three ways:

INTRODUCTION

HOSE

COUPLINGS

ADAPTORS

TECHNICAL

### 1. SEAT TO SEAT LENGTH. (RYCO STANDARD, UNLESS OTHERWISE SPECIFIED).

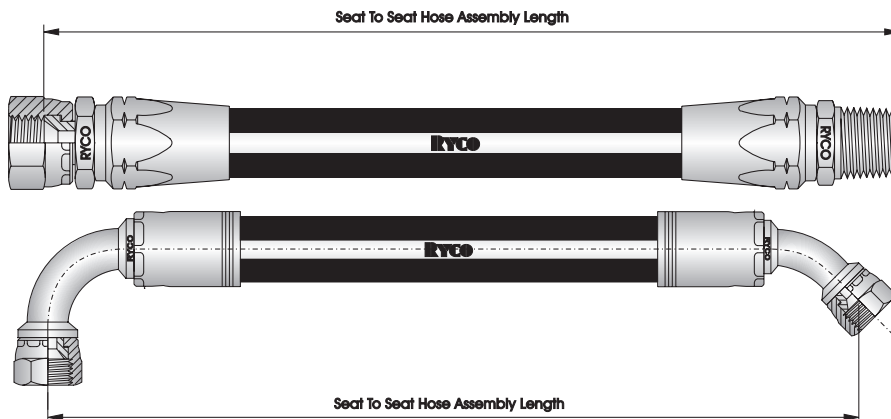

Length is measured from tip of seat to tip of seat.

### 2. OVERALL LENGTH. (OA)

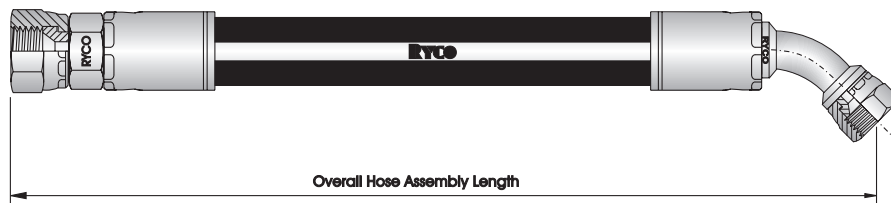

Length is measured from tip of nut to tip of nut.

### 3. CUT HOSE LENGTH. (CL)

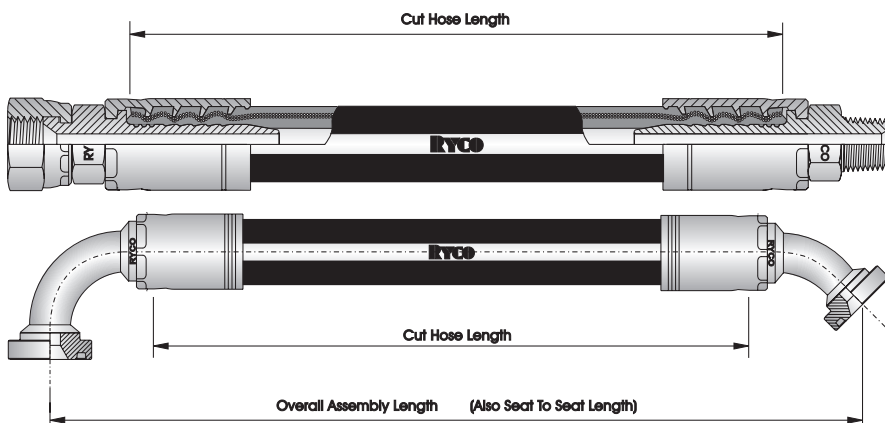

This is the length that the hose is cut to before couplings are attached. The length of the couplings is extra.

**NOTE:** For male fittings and flanged fittings, seat and overall length measurement points are the same.

### ORIENTATION OF FITTINGS.

Proper positioning of elbow end fittings on a hose is governed by the offset angle, or the amount of angular offset between connecting parts in the installation. If this angle of orientation is not correct in the construction of a hose assembly the performance and life of the assembly will be greatly reduced.

Orientation is determined by the number of degrees between the fitting furthest from the viewer and the fitting nearest to the viewer, measured in a clockwise direction.

**ORIENTATION TOLERANCES:**  
 $\pm 3^\circ$  on lengths up to 600 mm (24").  
 $\pm 5^\circ$  on lengths over 600 mm (24").

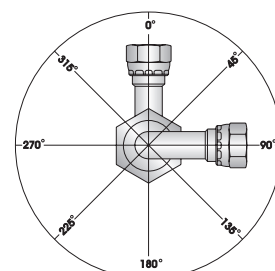

## HOW TO ORDER HOSE ASSEMBLIES & CUT-OFF ALLOWANCE (CA)

### HOW TO ORDER HOSE ASSEMBLIES

When ordering Hose Assemblies, specifying by the following system will assist; or alternatively supply a clear, concise drawing or sketch.

1. **Hose Type.**
2. **(Hose Protection or extra operations to hose)** - if applicable.
3. **Hose Assembly Length** (expressed in mm), followed by method of measurement:  
blank if "Seat to Seat Length"  
-OA if "Overall Length"  
-CL if "Cut Hose Length"
4. **Fitting End 1.**
5. **Fitting End 2.**
6. **Angle of Orientation** if both fittings are elbows and/or tube bends.

#### EXAMPLES:

1. **T3008D \* 1830 \* T2090-0808 \* T2040-0814** – Hose will be made 1830 mm Seat to Seat.
2. **T3008D \* 1830-OA \* T2090-0808 \* T2040-0814** – Hose will be made 1830 mm tip of T2090 male to tip of T2040 nut.
3. **T28D \* 1830 \* T2050-0808 \* T2730-0824 @ 135°** – Hose assembly will be manufactured so that when T2050-0808 is furthest away the T2730-0824 will be oriented 135° clockwise.
4. **T5008D \* 1640-CL \* L010-0812 \* L040-0817** – Hose will be cut to 1640 mm and length of fittings will be extra.
5. **H6012D \* (RSG-32 \* 1000) \* 1000-OA \* T7630-1236 \* T7720-1236** – Hose will be covered with RSG for full length of hose assembly. Length will be overall from T7630 tip to T7720 bend centreline.
6. **RQP212 \* (PIERCE \* 2200) \* 2200 \* T2090-1212 \* T2040-1217** – Hose cover will be pierced/pin pricked.
7. **T18D \* 1830 \* T2010-0808 \* T2020-0808 + S27-0808** – The length of the S27-0808 is extra, not included in the 1830 mm.

### CUT-OFF ALLOWANCE (CA)

Values for Cut-off Allowance (CA) dimensions are published in this Product Technical Manual.

CA dimensions allow calculation of the Hose Cut Length required to make a Hose Assembly of a particular Seat to Seat Length.

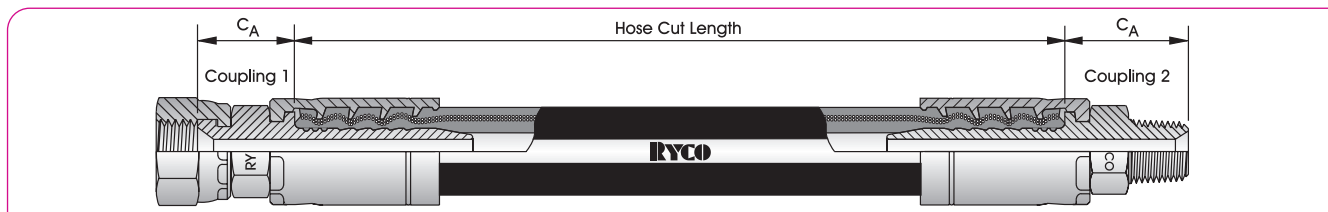

#### EXAMPLE:

For a Hose Assembly using **T2040-0609** coupling one end, and **T2090-0606** coupling other end, with a required Seat to Seat Length of 750 mm, calculate the Hose Cut Length required.

From page 201, CA dimension for T2040-0609 is 22 mm. This is "coupling 1" for the required hose assembly.

From page 197, CA dimension for T2090-0606 is 33 mm. This is "coupling 2" for the required hose assembly.

$$\text{Cut Length of Hose} = \text{Seat to Seat Length of Hose Assembly} - \text{CA (coupling 1)} - \text{CA (coupling 2)} = 750 \text{ mm} - 22 \text{ mm} - 33 \text{ mm} = 695 \text{ mm}$$

#### IMPORTANT NOTES:

##### 1. CHECK AND MEASURE COUPLING BEFORE CUTTING HOSE

For all Couplings, before calculating the Cut Length of the hose, measure and check that the CA dimension of the physical coupling complies with that published. CA dimensions may vary due to manufacturing method or design refinement.

##### 2. HOSE ASSEMBLY LENGTH GROWTH AFTER COUPLING ATTACHMENT

The CA dimension is measured from where the hose abuts when fully inserted, to the connection end seat of the coupling. With most Crimp Couplings<sup>1</sup>, and Field Attachable Couplings having ferrules<sup>2</sup>; due to compression of the hose within the coupling after attachment, a growth in length occurs, in addition to the published CA dimension. Growth varies with different types and sizes of hose and couplings. For longer hoses, and non-critical applications, it is common practice to ignore the growth, as the extra length generated usually does not affect the function of the hose assembly. In applications where the length of the hose assembly is critical, the growth must be allowed for when calculating Cut Length of hose. RYCO recommends measuring the growth when the first coupling is attached by measuring between reference points marked on the coupling and hose before and after coupling attachment, then adjusting the Cut Length of the hose to compensate.

3. See page 353 for extra information about CA dimensions for K000, L000, M000 and P000 Series Field Attachable couplings.

4. See note on page 186 regarding Drop Length (DL) and Cut-off Allowance (CA) published dimensions.

5. For Hose Assemblies, the following must be considered: Maximum Working Pressure of the Hose; End Style (Connector Termination), see pages 494 to 498 and Minimum Free Length, see page 471 in the "Safety Guide", pages 469 to 471

#### Note:

1) For T4000 Series couplings with SRX and SRF hose series, growth varies and must be measured each time.

2) For practical purposes, 8000 Series Push-On and 33000 Series couplings do not experience extra growth.

## SELECTION, INSTALLATION AND MAINTENANCE OF HOSE AND HOSE ASSEMBLIES

### SCOPE:

1. Many factors affect the selection, making, installation and maintenance of hose assemblies. This catalogue, RYCO Hydraulics (RYCO), and The Society of Automotive Engineers recommended practice SAE J1273, have useful information about selecting, making, installing and servicing hydraulic hose assemblies. For further information, please contact your local RYCO representative.

RYCO recommends hose and coupling combinations in the catalogue only after completing extensive testing. Evaluation of a hose and coupling combination requires considerable impulse testing and cannot be determined by a simple burst or pressure hold test. RYCO disclaims all liability for any hose assembly made in violation of RYCO recommendations, procedures and current crimp data. Crimp data is updated from time to time.

The consumer's exclusive remedy with respect to any claim shall be a refund of the purchase price or replacement of the product at the option of RYCO. In no event shall RYCO be liable for any incidental or consequential damages whatsoever.

**WARNING: IMPROPER SELECTION, INSTALLATION, OR MAINTENANCE MAY RESULT IN PREMATURE FAILURES, BODILY INJURY, PROPERTY DAMAGE.**

### SELECTION:

2. The following is a list of factors which must be considered before final hose selection can be made:
  - 2.1 **Internal Pressure** – After determining the system pressure, hose selection must be made so that the recommended maximum operating pressure is equal to or greater than the system pressure. Surge pressures higher than the maximum operating pressure will shorten hose life and must be taken into account by the hydraulic engineer. Hose fitting rated pressures should also be considered, as the maximum working pressure is based on the whole hose assembly and not just the hose alone.
  - 2.2 **External Pressure:** In certain applications the external environmental pressures may exceed the fluid pressure inside the hose, therefore these factors need to be considered.
  - 2.3 **Suction** – Hoses used for suction applications must be selected to ensure that the hose will withstand the vacuum and pressure of the system.
  - 2.4 **Temperature** – Care must be taken to ensure that fluid and ambient temperatures, both static and transient, do not exceed the limitations of the hose. Special care must be taken when routing near hot objects such as manifolds.
  - 2.5 **Fluid Compatibility** – Hose selection must assure compatibility of the hose tube, cover, and fittings with the fluid used. Additional caution must be observed in hose selection for gaseous applications. For full compatibility table please refer to page "Chemical Compatibility for Hose" on page 475 in the Technical Section of this manual.
  - 2.6 **Size** – Transmission of power by means of pressurised fluid varies with pressure and rate of flow. The size of the components must be adequate to keep pressure losses to a minimum and avoid damage to the hose due to heat generation or excessive turbulence.
  - 2.7 **Routing** – Attention must be given to optimum routing to minimise inherent problems.
  - 2.8 **Environment** – Care must be taken to ensure that the hose and fittings are either compatible with, or protected from, the environment to which they are exposed. Environmental conditions such as ultraviolet light, ozone, salt water, chemicals and air pollutants can cause degradation and premature failure and, therefore, must be considered.
  - 2.9 **Mechanical Loads** – External forces can significantly reduce hose life. Mechanical loads which must be considered include excessive flexing, twist, kinking, tensile or side loads, bend radius, and vibration. Use of swivel type fittings or adaptors may be required to ensure no twist is put into the hose. Unusual applications may require special testing prior to hose selection.
  - 2.10 **Abrasion** – While a hose is designed with a reasonable level of abrasion resistance, care must be taken to protect the hose from excessive abrasion which can result in erosion, snagging, and cutting of the hose cover. Exposure of the reinforcement will significantly accelerate hose failure.
  - 2.11 **Proper End Fitting** – Care must be taken to ensure proper compatibility exists between the hose and coupling selected based on the manufacturer's recommendations substantiated by testing to industry standards such as SAE J517.
  - 2.12 **Length** – When establishing proper hose length; motion absorption, hose length changes due to pressure, as well as hose and machine tolerances must be considered.
  - 2.13 **Specifications and Standards** – When selecting hose; government, industry, and manufacturer's specifications and recommendations must be reviewed as applicable.
  - 2.14 **Hose Cleanliness** – Hose components vary in cleanliness levels. Care must be taken to ensure that the assemblies selected have an adequate level of cleanliness for the application.
  - 2.15 **Electrical Conductivity** – Certain applications require that hose be non-conductive to prevent electrical current flow. Other applications require the hose to be sufficiently conductive to drain off static electricity. Hose and fittings must be chosen with these needs in mind.
  - 2.16 **High Pressure Gas** – Do not use hydraulic hose to transmit high pressure gases.

## HOSE SELECTION

- 2.17 **Vibration:** Vibration can reduce hose service life. If necessary, conduct tests to evaluate the effects of frequency and amplitude of system vibration on a hose assembly. Clamps of other devices may be used to reduce the effects of vibration.

### INSTALLATION:

3. After selection of proper hose, the following factors must be considered by the installer:
- 3.1 **Pre-installation Inspection** – Prior to installation, a careful examination of the hose must be performed. All components must be checked for correct style, size and length. In addition, the hose assembly, and each of the individual components comprising the assembly, must be examined for cleanliness, I.D. obstructions, blisters, loose cover, or any other visible defects.
  - 3.2 **Follow Manufacturer's Assembly Instructions.**
  - 3.3 **Minimum Bend Radius** – Installation at less than minimum bend radius may significantly reduce hose life. Particular attention must be given to preclude sharp bending at the hose/fittings juncture which may result in leaking, hose rupturing, or the hose assembly blowing apart.
  - 3.4 **Lengths:** Unnecessarily long hose can increase pressure drop and affect system performance. When pressurised, hose that is too short may pull loose from its fittings, or stress the hose fitting connections, causing premature metallic or seal failures.
  - 3.5 **Twist Angle and Orientation** – Hose installations must be such that relative motion of machine components produces bending of the hose rather than twisting.
  - 3.6 **Securement** – In many applications, it may be necessary to restrain, or guide, the hose to protect it from damage by unnecessary flexing, pressure surges, and contact with other mechanical components. Care must be taken to ensure such restraints do not introduce additional stress or wear points.
  - 3.7 **Proper Connection of Ports** – Proper physical installation of the hose requires a correctly installed port connection while ensuring that no twist or torque is transferred to the hose.
  - 3.8 **Avoid External Damage** – Proper installation is not complete without ensuring that all tensile loads, side loads, kinking, flattening, potential abrasion, thread damage, or damage to sealing surfaces are corrected or eliminated.
  - 3.9 **System Check out** – After completing the installation, all entrapped air must be eliminated, then the system must be pressurised to the maximum system pressure and checked for proper function, and for freedom from leaks.

### NOTE: AVOID POTENTIAL HAZARDOUS AREAS WHILE TESTING.

### MAINTENANCE:

4. Even with proper selection and installation, hose life may be significantly reduced without a continuing maintenance program. Maintenance and Inspection frequency should be determined by the severity of the application and risk potential. A maintenance program should include the following as a minimum.
- 4.1 **Hose Storage** – Hose products in storage can be adversely affected by temperatures, humidity, ozone, sunlight, oils, solvents, corrosive liquids and fumes, insects, rodents, radioactive materials, sharp edges and abrasive surfaces, electric or strong magnetic fields, mould and fungi. Storage areas should be relatively cool and dark and free of dust, dirt, dampness and mildew. Store hose in a manner that facilitates age control and first-in, first-out usage based on manufacturing date on hose or hose assembly.
  - 4.2 **Visual Inspection** – Any of the following conditions require immediate system shut down and replacement of the hose assembly:
    - a) Leaks at fittings or in hose. (Leaking fluid is a fire hazard.)
    - b) Damaged, cut, or abraded cover. (Any reinforcement exposed.)
    - c) Kinked, crushed, flattened, or twisted hose.
    - d) Hard, stiff, heat cracked, or charred hose.
    - e) Blistered, soft, degraded, or loose cover.
    - f) Cracked, damaged, or badly corroded fittings.
    - g) Slippage or movement of fittings on the hose.
  - 4.3 **Visual Inspection** – The following items must be tightened, repaired or replaced as required.
    - a) Leaking port conditions.
    - b) Clamps, guards, shields.
    - c) Remove excessive dirt build-up.
    - d) System fluid level, fluid type, and any air entrapment.
  - 4.4 **Functional Test** – Operate the system at maximum operating pressure and check for possible malfunctions and freedom from leaks.
- NOTE: AVOID POTENTIAL HAZARDOUS AREAS WHILE TESTING.**
- 4.5 **Replacement Intervals** – Specific replacement intervals must be considered based on previous service life, government or industry recommendations, or when failures could result in unacceptable down time, damage, or injury risk.



# SAFETY GUIDE

## FOR THE SELECTION AND USE OF HOSE, FITTINGS AND RELATED ACCESSORIES

Failure or improper selection or improper use of hose, fittings, or related accessories can cause death, personal injury and property damage. Possible consequences of failure or improper selection or improper use of hose, fittings, or related accessories include, but are not limited to:

- Fittings blown off at high speed.
- High velocity fluid discharge.
- Explosion, or burning, of the conveyed fluid.
- Electrocution from high voltage electric power lines or other sources of electricity.
- Contact with suddenly moving, or falling, objects that are held in position, or moved, by conveyed fluid.
- Injections by high-pressure fluid discharge.
- Dangerously whipping hose.
- Contact with conveyed fluids that may be hot, cold, toxic or otherwise injurious.
- Sparking or explosion caused by static electricity build-up.
- Sparking, or explosion, while spraying paint or other flammable liquid.

### 1. GENERAL INSTRUCTIONS:

- 1.1 **Scope:** This safety guide provides instructions for selecting and using (including assembling, installing and maintaining) hose fittings (including all products commonly called “fittings” or “couplings” for attachment to hose), and related accessories (including crimping machines and tooling). This safety guide is to be used in conjunction with the specific publications for the specific hose, fittings and related accessories that are being considered for use.
- 1.2 **Fail-Safe:** Hose and hose assemblies can and do fail. Design all systems in a fail-safe mode, so that failure of the hose or hose assembly or related accessories will not endanger persons or property.
- 1.3 **Distribution:** Provide a copy of this safety guide to each person who is responsible for selecting, or using, hose and fittings and related accessories. Do not select, or use, hose and fittings or related accessories without thoroughly understanding this safety guide.
- 1.4 **User Responsibility:** Due to the wide variety of operating conditions and uses for hose and fittings and related accessories, RYCO do not represent or warrant that any particular hose or fitting or related accessories is suitable for any specific end use. This safety guide does not analyse all technical parameters that must be considered in selecting a product. The product user, through its own analysis and testing, is solely responsible for:
  - The final selection of the hose and fittings and related accessories.
  - Assuming that requirements are met and the use presents no health or safety hazards.
  - Providing all appropriate health and safety warnings where hose and fittings and related accessories are used.
- 1.5 **Additional Questions:** Contact the RYCO Hydraulics Technical Department if you have any questions or require any additional information.

### 2. HOSE AND FITTING SELECTION INSTRUCTIONS:

- 2.1 **Electrical Conductivity:** Certain applications require that a hose be non-conductive to prevent electrical current flow. Other applications require the hose to be sufficiently conductive to drain off static electricity. Extreme care must be exercised when selecting hose and fittings for these or any other applications. For applications that require hose to be electrically non-conductive, including but not limited to applications near high voltage electric lines, only special non-conductive hose can be used. The manufacturer of the equipment must be consulted to be certain that the hose and fittings selected are correct for the application. Do not use any RYCO hose or fittings for any such application unless:
  - (i) the application is expressly approved by RYCO
  - (ii) the hose is both orange colour and marked “non-conductive”
  - (iii) the manufacturer of the equipment specifically approves the particular RYCO hose and fittings.

Do not use any RYCO hose or fittings for conveying paint in airless spraying or similar applications without the written approval of RYCO in each case. A special hose and fittings assembly is required for this application. If the correct hose and fitting application is not used for this application, static electricity can build up and cause sparks that may result in an explosion and/or fire.

The electrical conductivity or non-conductivity of hose and fittings is dependent upon many factors and may be susceptible to change.
- 2.2 **Pressure:** Hose selection must be made so that the published maximum recommended working pressure of the hose is equal or greater than the maximum system pressure. Surge pressures in the system higher than the published maximum recommended working pressure will cause failure, or shorten hose life.
- 2.3 **Suction:** Hoses used for suction applications must be selected to ensure that the hose will withstand the vacuum and pressure of the system.
- 2.4 **Temperature:** Be certain that fluid and ambient temperatures, both steady and transient, do not exceed the limitations of the hose. Care must be taken when routing hose near hot objects such as manifolds.
- 2.5 **Fluid Compatibility:** Hose selection must assure compatibility of the hose tube, cover, reinforcement, and fittings with the fluid media used.



- 2.6 **Permeation:** Permeation (that is, seepage through the hose) will occur from inside the hose to the outside environment when hose is used with gases, liquid and gas fuels, and refrigerants (including but not limited to such materials such as helium, fuel, oil, natural gas or freon). This permeation may result in high concentrations of vapours which are potentially flammable, explosive, or toxic, and in loss of fluid. You must take into account the fact that permeation will occur and could be hazardous.
- Permeation of moisture from the outside environment to inside the hose will also occur. If this moisture permeation would have detrimental effects (particularly for, but not limited to, refrigeration and air conditioning systems), incorporation of appropriate system safeguards should be selected and used. Rubber hoses should not be painted without consulting RYCO first.
- 2.7 **Size:** Transmission of power by means of pressurised fluid varies with pressure and rate flow. The size of the components must be adequate to keep pressure losses to a minimum and avoid damage due to heat generation of excessive fluid velocity.
- 2.8 **Routing:** Attention must be given to optimum routing to minimise inherent problems.
- 2.9 **Environment:** Care must be taken to ensure that the hose and fittings are either compatible with or protected from the environment to which they are exposed including but not limited to ultraviolet radiation, sunlight, heat, ozone, moisture, water, salt water, chemicals and air pollutants.
- 2.10 **Mechanical Loads:** Consideration must be given to excessive flexing, twist, kinking, tensile or side loads, bend radius, and vibration. Use of swivel type fittings or adaptors may be required.
- 2.11 **Physical Damage:** Care must be taken to protect hose from wear, snagging and cuts.
- 2.12 **Proper End Fittings:** See instructions 3.2 through 3.5. These recommendations may be substantiated by testing to industry standards.
- 2.13 **Length: When** establishing a proper hose length; motion absorption, hose length changes due to pressure, and hose and machine tolerances must be considered.
- 2.14 **Specifications and Standards:** When selecting hose and fittings; government, industry, and RYCO specifications and recommendations must be reviewed and followed as applicable.
- 2.15 **Hose Cleanliness:** Hose components may vary in cleanliness levels. Care must be taken to ensure that the assembly selected has an adequate level of cleanliness for the application.
- 2.16 **Fire Resistant Fluids:** Some fire resistant fluids require the same hose as used with petroleum oil. Some use a special hose, while a few fluids will not work with any hose at all. See General Instructions 1.5 and Hose and Fitting Selection Instructions 2.5.
- 2.17 **Radiant Heat:** Hose can be heated to destruction without contact by nearby items such as hot manifolds or molten metal.
- 2.18 **Welding and Brazing:** Heating of plated parts, including hose fittings and adaptors, above 232°C (450°F) such as during welding, brazing, or soldering may emit deadly gases.
- 2.19 **Atomic Radiation:** Atomic radiation affects all materials used in hose assemblies. Do not expose hose assemblies to atomic radiation.

### 3. HOSE AND FITTING ASSEMBLY AND INSTALLATION INSTRUCTIONS:

- 3.1 **Pre-Installation Inspection:** Prior to installation, a careful examination of the hose assembly must be performed. All components must be checked for correct style, size, and length. The hose must be examined for cleanliness, obstructions, blisters, cover looseness, or any other visible defects.
- 3.2 **Hose and Fitting Assembly:** Do not assemble a RYCO fitting on a RYCO hose that is not specifically listed for that fitting by RYCO. Do not assemble RYCO fittings on another manufacturer's hose or a RYCO hose on another manufacturer's fitting unless RYCO approves the assembly in writing, and the user verifies the assembly and the application through analysis and testing. See instruction 1.4. The RYCO published instructions must be followed for assembling the fittings on the hose. These instructions are provided in the RYCO catalogue.
- 3.3 **Related Accessories:** Do not crimp or swage any RYCO hose or fitting with anything but the proper RYCO swage machine or crimp machine and in accordance with RYCO published instructions. Do not crimp or swage another manufacturer's hose fitting with a RYCO crimp machine or swage machine unless authorised in writing by RYCO.
- 3.4 **Safety Equipment:** During fabrication, use proper safety equipment, including eye protection, respiratory protection, and adequate ventilation.
- 3.5 **Reuse of Hose and Fittings:** Damaged hoses or hose fittings shall not be used.
- 3.6 **Assembly inspection:** After assembly, hose assemblies shall be inspected for visible defects and interior obstructions, such as tube bulges, etc.
- 3.7 **Marking:** Hose assemblies shall be marked in accordance with any relevant standards.
- 3.8 **Parts:** Do not use any RYCO hose or fitting part unless used with the correct RYCO mating parts, in accordance with published instructions, unless authorised in writing by RYCO.
- 3.9 **Field Attachable/Permanent:** Field Attachable couplings may be reattached once only after their first use, provided that they have not been part of a hose assembly that has failed, and are in a fit condition for reuse. Do not reuse any field attachable hose coupling that has blown or pulled off a hose. Do not reuse any permanent (that is, crimped or swaged) hose fittings or any part thereof.

- 3.10 **Minimum Bend Radius:** Installation of a hose at less than the minimum listed bend radius may significantly reduce hose life.
- 3.11 **Twist Angle and Orientation:** Hose installations must be such that relative motion of machine components does not produce twisting.
- 3.12 **Securement:** In many applications, it may be necessary to restrain, protect, or guide the hose to protect it from damage. Care must be taken to ensure such restraints do not introduce additional stress or wear points.
- 3.13 **Proper Connection of Ports:** Proper physical installation of the hose requires a correctly installed port connection while ensuring that no twist or torque is transferred to the hose.
- 3.14 **Assembly Torque:** The correct torque instructions and specifications must be followed to obtain a proper seal when a hose assembly is attached to a port, an adaptor or another assembly.
- 3.15 **External Damage:** Proper installation is not complete without ensuring that tensile loads, side loads, kinking, flattening, potential abrasion, thread damage, or damage to sealing surfaces are corrected or eliminated. See instruction 2.10.
- 3.16 **System Check-out:** After completing the installation, all air entrapment must be eliminated and the system pressurised to the maximum system pressure and checked for proper function and freedom from leaks.  
NOTE: Avoid potential hazardous areas while testing.
- 3.17 **Minimum Free Length of Hose Assemblies:** Occasionally requests or orders arise for hydraulic hose assemblies where the 'Free Length' of hose between the ferrules of the couplings is not long enough, and could hinder the ability of the hose assembly to function properly. This is particularly the case when utilising very short hose assemblies, where a shortening or shrinkage of the hose under pressure may result in hose and coupling separation. In addition, small misalignments, vibration and other displacements may induce very high stresses upon the hose/coupling juncture, as there is little capacity for the flexible nature of the hose to compensate.

Due to the possible problems associated with using very short hose assemblies, RYCO has adopted the following general rule (equation) for the allowable Minimum Free Length (MFL) of hose to be used as a guide when fabricating or ordering a hydraulic hose assembly.

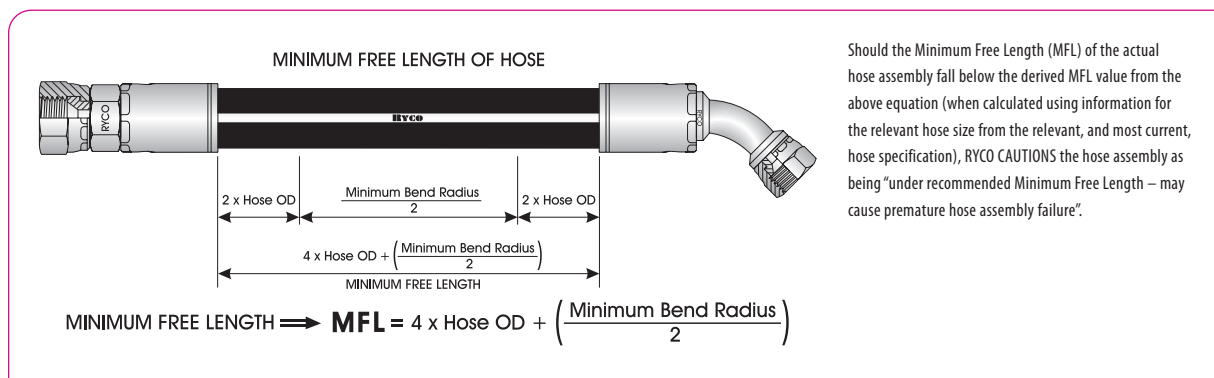

**4. HOSE AND FITTING MAINTENANCE INSTRUCTIONS:**

Even with proper selection and installation, hose life may be significantly reduced without a continuing maintenance program. Frequency should be determined by the severity of the application and risk potential. A maintenance program must include the following as a minimum.

- 4.1 **Visual Inspection Hose/Fitting:** Any of the following conditions require immediate system shut down and replacement of the hose assembly:
  - Slippage or movement of fittings on the hose
  - Damaged, cut or abraded cover
  - Hard, stiff, heat cracked, or charred hose
  - Cracked, damaged, or badly corroded fittings
  - Leaks at fitting or in hose
  - Kinked, crushed, flattened or twisted hose
  - Blistered, soft, degraded or loose cover
  - Unusual noise, odour or heat.
- 4.2 **Visual Inspection All Other:** The following items must be tightened, repaired or replaced as required:
  - Leaking port conditions
  - Remove excess dirt build-up
  - Clamps, guards, shields
  - System fluid level, fluid type and any air entrapment
- 4.3 **Functional Test:** Operate the system at maximum operating pressure and check for possible malfunctions and freedom from leaks.
- 4.4 **Replacement Intervals:** Specific replacement intervals must be considered based on previous service life, government or industry recommendations. See instructions 1.2.

INTRODUCTION

HOSE

COUPLINGS

ADAPTORS

TECHNICAL



Some RYCO Hose Series are not listed on page 58: **T1F, TJ2D, M2G, M1, RTH1, MP1**.

These Hoses are specific purpose Hoses, and their temperature limits are specified in the Hose Section of this Product Technical Manual. Contact RYCO Technical Department for any further queries.

Other RYCO Hose Series are listed on page 58. The Maximum Working Temperatures for these hoses, as listed in the Hose Section of this Product Technical Manual are for use with general purpose, mineral (petroleum) oil based hydraulic fluids, except where otherwise stated. Temperature limits for other hydraulic fluids, and some other common applications, are listed on page 58.

### CAUTION:

Life expectancy of hoses is shortened at high temperatures. Detrimental effects increase when temperature is elevated, and also when; operating pressure, flow velocity, duration and frequency of exposure, and level of impurities in the media are high. Actual service life at temperatures approaching the recommended limits will depend on the particular application and the fluid being used.

Maximum Working Temperatures refer to the temperature of the media in the hose; not the environmental temperature around the outside of the hose. Please contact RYCO Technical Department for environmental temperatures in excess of 80°C (176°F), except **RQP1, RQP2, RQP5** and **RQP6** Series where environmental temperature is the same as media temperature.

Maximum Working Temperatures shown are for continuous temperatures. Slightly higher intermittent temperatures (up to 10% of time) may be acceptable with some hoses and some fluids, if reduced service life is acceptable. Please contact RYCO Technical Department for more information.

DO NOT expose Hose to Maximum Temperature and Maximum Working Pressure at the same time.

The fluid manufacturer's recommended maximum operating temperature for the fluid must not be exceeded. If different to the temperatures listed in the following table, the lower limit must take precedence. We recommend keeping the hose filled with the pressure medium at all times. Further information available on request.

## SAFETY GUIDE – MAXIMUM TEMPERATURE LIMITS

HOSE COVER	GROUP 1	GROUP 2	GROUP 3	GROUP 4	GROUP 5
<b>ENERGY</b>	E1, E2, EC1, EC2, DK1E, DK2E				
<b>DIEHARD</b>	T3000D, T4000D, T5000D, T6000D, T1D, T2D, TXA2D, DF1D, DF2D, DK1D, DK2D, TJ2D, PL1D	H3000D, H4000D, H5000D, H6000D, C6000D, H12D, R4SPD, R4SHD			
<b>SLIDER</b>	T3000S, T4000S, T5000S, T6000S, T1S, T2S, DK1S, DK2S	H3000S, H4000S, H5000S, H6000S, C6000S, H12S			
<b>SURVIVOR</b>	BT1 ***	D2B	RQP1, RQP2		
<b>ICEBREAKER</b>					T3600C, H5000C, T2C
<b>OTHER SERIES</b>	SRF, SRX, M2, T5, T1F, PL1, PL1PV, CS1000, MS1000		RQP5, RQP6	TP7, TP7N, TP7T, TP7TN, TP8, TP8N, TP8T, TP8TN, TP3000, TPGL	

MEDIA	TEMPERATURE LIMITS				
-------	--------------------	--	--	--	--

<b>GENERAL PURPOSE MINERAL PETROLEUM BASED HYDRAULIC OIL <sup>1</sup></b>	-40°C to +100°C -40°F to +212°F	-40°C to +121°C -40°F to +250°F	-40°C to +150°C -40°F to +302°F RQP6: -40° to +135°C -40°F to +275°F	-40°C to +95°C -40°F to +203°F	-60°C to +100°C -76°F to +212°F
<b>WATER</b>	0°C to +71°C +32°F to +160°F	0°C to +71°C +32°F to +160°F	0°C to +121°C +32°F to +250°F	0°C to +70°C +32°F to +158°F	0°C to +71°C +32°F to +160°F
<b>WATER IN MINERAL OIL 40% to 80% water</b>	-40°C to +85°C -40°F to +185°F	-40°C to +85°C -40°F to +185°F	-40°C to +121°C -40°F to +250°F	-40°C to +70°C -40°F to +158°F	-60°C to +80°C -60°F to +176°F
<b>MINERAL OIL IN WATER more than 80% water</b>	-40°C to +85°C -40°F to +185°F	-40°C to +85°C -40°F to +185°F	-40°C to +121°C -40°F to +250°F	-40°C to +70°C -40°F to +158°F	-60°C to +80°C -60°F to +176°F
<b>WATER/GLYCOL</b>	-40°C to +85°C -40°F to +185°F	-40°C to +85°C -40°F to +185°F	-40°C to +121°C -40°F to +250°F	-40°C to +70°C -40°F to +158°F	-60°C to +80°C -60°F to +176°F
<b>GLYCOL</b>	-40°C to +85°C -40°F to +185°F	-40°C to +85°C -40°F to +185°F	-40°C to +85°C -40°F to +185°F	-40°C to +70°C -40°F to +158°F	-60°C to +80°C -60°F to +176°F
<b>PHOSPHATE ESTERS</b>	Not suitable	Not suitable	Not suitable	40°C to +70°C -40°F to +158°F See note 2	Not suitable
<b>AIR <sup>3</sup></b>	-40°C to +71°C (-40°F to +160°F)	-40°C to +71°C -40°F to +160°F see Note 3	-40°C to +121°C -40°F to +250°F RQP6: -40°C to +100°C -40°F to +212°F See note 3	-40°C to +71°C -40°F to +160°F see Note 3	-60°C to +71°C -60°F to +160°F
<b>PETROL GASOLINE</b>	Contact RYCO	Contact RYCO	Contact RYCO	Contact RYCO	Contact RYCO
<b>DIESEL FUEL</b>	PL1D: -40°C to +49°C -40°F to +160°F T5: -40°C to +71°C -40°F to +160°F OTHERS: -40°C to +50°C -40°F to +122°F	-40°C to +50°C -40°F to +122°F	RQP1 and RQP2 -40°C to 100°C -40°F to +212°F RQP6: -40°C to +71°C -40°F to +160°F		-60°C to +71°C -60°F to +160°F
<b>ENGINE LUBRICATING OIL, GEARBOX OIL</b>	-40°C to +100°C -40°F to +212°F	-40°C to +100°C -40°F to +212°F	-40°C to +100°C -40°F to +212°F	-40°C to +95°C -40°F to +203°F	-60°C to +80°C -60°F to +176°F
<b>AUTOMATIC TRANSMISSION FLUID</b>	-40°C to +100°C -40°F to +212°F	-40°C to +100°C -40°F to +212°F	-40°C to +100°C -40°F to +212°F	-40°C to +95°C -40°F to +203°F	-60°C to +80°C -60°F to +176°F

- 1 For highly refined and special purpose mineral based hydraulic oils (for example aviation hydraulic oils, MIL spec oils, etc), contact RYCO Technical Department.
- 2 Not suitable for use with aerospace type phosphate esters such as Monsanto Skydrol 500B, Stauffer Aero-Safe 2300W and Chevron Hy-jet IV.
- 3 For use with Air at pressures above 17,2 bar (250 psi), cover of hose must be perforated/pin-pricked (except RQP5 and T5), to allow air permeating through hose to escape without blistering the cover. Maximum working pressure of wire braid and spiral reinforced hose must be reduced by 30% (except for RQP1 and RQP2). Observe all State and Federal Safety Regulations.

INTRODUCTION

HOSE

COUPLINGS

ADAPTORS

TECHNICAL

# TECHNICAL

## CHARACTERISTICS OF HOSE ELASTOMERS

The characteristics shown below are for the normal, or usual, range of these specific Elastomers. Characteristics can be changed somewhat, through different compounding, to meet the requirements of specialised applications. Each elastomer has a unique combination of strengths and weaknesses. Depending on each specific application, the elastomer must possess the correct combination of properties if it is to perform satisfactorily.

Tube and cover elastomers may occasionally be upgraded to take advantage of improved materials and technology.

For detailed information on specific hose tube or cover check the Chemical Compatibility Table on page 475, and also the specific hose specifications page.

COMMON NAME Chemical Name	NEOPRENE Poly-Chloroprene	NITRILE Acrylonitrile & Butadiene	HYPALON™ Chlorosulfonated Polyethylene	EPDM Ethylene Propylene Diene	CPE Chlorinated Polyethylene	POLYESTER Polyamide Resin	TEFLON™ Fluorinated Thermoplastic
<b>Common</b>	CR	NBR	CSM	EPDM	CPE	PE-E	PTFE
<b>Flame Resistance</b>	Very Good	Poor	Good	Poor	Good	Poor	Good
<b>Petroleum Base Oils</b>	Good	Excellent	Very Good	Poor	Very Good	Very Good	Excellent
<b>Diesel Fuel</b>	Good to Excellent	Excellent	Good	Poor	Very Good	Very Good	Excellent
<b>Resistance to Gas Permeation</b>	Good	Good	Good to Excellent	Fair to Good	Good	Good	Good to Excellent
<b>Weather</b>	Good to Excellent	Fair to Good	Very Good	Excellent	Good	Excellent	Excellent
<b>Ozone</b>	Good to Excellent	Poor for Tube Good for Cover	Very Good	Excellent	Good	Good	Excellent
<b>Heat</b>	Good	Good	Very Good	Excellent	Excellent	Good	Excellent
<b>Low Temperature</b>	Fair to Good	Poor to Fair	Poor	Good to Excellent	Good	Good	Excellent
<b>Water - Oil Emulsions</b>	Excellent	Excellent	Good	Poor	Excellent	Very Good	Excellent
<b>Water/Glycol Emulsions</b>	Excellent	Excellent	Excellent	Excellent	Excellent	Very Good	Excellent
<b>Phosphate Esters to 82°C (180°F)</b>	Fair (For Cover)	Poor	Excellent (not for Aerospace types)	Very Good	Very Good	Good	Excellent
<b>Phosphate Ester Base Emulsions</b>	Fair (For Cover)	Poor	Excellent (not for Aerospace types)	Very Good	Very Good	Good	Excellent

NOTE: HYPALON™ and TEFLON™ are Trademarks of DUPONT

## CHEMICAL COMPATIBILITY FOR HOSE

The following Chemical Compatibility Chart is for guidance only.  
 In all cases, testing is advised to determine the application suitability.  
 Material for Couplings and Adaptors must also be compatible - refer to RYCO Technical Department.  
 Specified resistance applies only at room temperature unless otherwise stated, and within the listed concentration.

CHEMICAL NAME	TUBE MATERIAL						
	NEOPRENE	NITRILE	NITRILE PVC	CPE	HYPALON™	POLYESTER	TEFLON™
Acetic Acid (25%)	2	X	2	1	2	X	1
Acetone	X	X	X	1	X	X	1
Acetylene	NO HOSE AVAILABLE						
Air (71°C, 166°F)	1	1	1	1	1	1	1
Air (82°C, 180°F)	2	2	2	1	2	2	1
Air (93°C, 199°F)	X	X	X	1	2	X	1
Amyl Acetate	X	X	X	2	X	X	1
Aniline	X	X	X	2	X	-	1
Benzene (Benzol)	X	X	X	X	X	X	1
Butyl Acetate	X	X	X	2	X	X	1
Butyl Alcohol (Butanol)	2	X	X	1	2	2	1
Carbon Dioxide (Dry)	2	1	1	1	1	-	1
Carbon Dioxide (Wet)	2	1	1	1	1	-	1
Carbon Disulfide	X	X	X	2	X	-	1
Chlorine Gas (Dry & Wet)	NO HOSE AVAILABLE						
Chlorine Water (25%)	X	X	X	-	2	X	1
Chloroform	X	X	X	-	X	X	1
Cyclohexane	X	2	X	1	X	2	1
Diesel fuel (under 50°C, 122°F)	X	1	X	2	X	1	1
Ethers (under 50°C, 122°F)	X	2	2	1	2	X	1
Ethyl Acetate	X	X	X	2	X	2	1
Ethyl Alcohol (Ethanol)	1	1	-	1	1	2	1
Ethyl Cellulose	-	-	-	1	-	-	1
Ethyl Chloride (Wet)	2	X	X	-	X	-	1
Ethylene Glycol (under 66°C, 151°F)	1	1	1	1	1	1	1
Fluorine (Liquid)	NO HOSE AVAILABLE						
Formaldehyde 37%	2	2	-	1	2	2	1
Fuel A (ASTM)	X	2	2	1	1	-	-
Fuel B (ASTM)	X	2	X	2	X	-	-
Fuel Oil	X	1	X	1	X	2	1
Glycerine (Glycerol)	1	1	1	1	1	1	1
Grease (Petroleum Base)	2	1	2	-	2	1	1
Hexane (under 50°C, 122°F)	X	1	2	2	1	2	1
Hydraulic Fluid (Phosphate Ester Base)	X	X	X	1	1	2	1
Hydraulic Fluid (100°C, 212°F) (Std. Petroleum Oils)	2	1	2	1	1	1	1
Hydrochloric Acid (15%)	X	X	X	1	2	X	1
Hydrochloric Acid (37%)	X	-	X	1	2	X	1
Hydrogen (Gas)	1	1	-	1	-	2	1
Hydrogen Peroxide (30%)	X	2	X	1	2	X	1

CHEMICAL NAME	TUBE MATERIAL						
	NEOPRENE	NITRILE	NITRILE PVC	CPE	HYPALON™	POLYESTER	TEFLON™
Isopropyl Alcohol	2	2	2	1	2	-	1
Kerosene	X	2	X	1	X	2	1
L.P.G.	USE L.P.G. HOSE ONLY						
Lubricating Oils (under 50°C, 122°F)	2	1	2	1	2	1	1
Methyl Alcohol (Methanol) 100%	1	1	1	1	1	2	1
Methyl Chloride	X	X	X	X	X	2	1
Methyl Ethyl Ketone (MEK)	X	X	X	2	X	2	1
Naphtha (Low Aromatics)	X	2	X	1	X	X	1
Natural Gas	USE L.P.G. HOSE ONLY						
Nitric Acid (10%)	X	X	X	1	2	X	1
Nitric Acid (40%)	X	X	X	X	X	X	1
Oxalic Acid (10% cold)	X	X	X	1	2	X	1
Ozone (Dry)	2	X	2	1	2	2	1
Paint Solvents (Oil Base)	X	X	-	-	X	2	1
Perchloroethylene	X	X	X	2	X	X	1
Phenol (Carbolic Acid)	X	X	X	1	X	X	1
Phosphoric Acid (50%)	2	2	X	1	1	X	1
Propane Gas	USE L.P.G. HOSE ONLY						
Sodium Hydroxide (40%)	1	2	-	1	1	X	1
Sodium Hydroxide (50%, under 45°C, 113°F)	2	X	X	1	1	X	1
Sodium Hydroxide (50%, under 82°C, 180°F)	-	-	-	1	2	X	1
Sulphur Dioxide (Dry)	X	X	X	-	2	X	1
Sulphuric Acid (10%)	1	2	2	1	1	X	1
Sulphuric Acid (93%)	X	X	X	-	X	X	1
Toluene (Toluol)	X	X	X	X	X	2	1
Trichloroethylene	X	X	X	2	X	2	1
Vegetable Oils	2	1	2	1	2	1	1
Xylene	X	X	-	X	-	2	1

**KEY**  
 1 = Excellent Resistance  
 2 = Good Resistance  
 X = Not Recommended  
 - = No Data Available

**NOTE:** HYPALON™ and TEFLON™ are Trademarks of DUPONT

INTRODUCTION

HOSE

COUPLINGS

ADAPTORS

TECHNICAL

### ASSEMBLY INSTRUCTIONS FOR:

RYCO FIELD ATTACHABLE COUPLINGS WITH MATCHED SIZES OF RYCO NON-SKIVE HOSE.

USE ONLY RYCO BT1, E2, M2, M2G, RQP1, RQP2, RQP5, T1D, T1F, T2D, TXA2D, T5 and TPGL SERIES HOSE.

#### STEP ONE

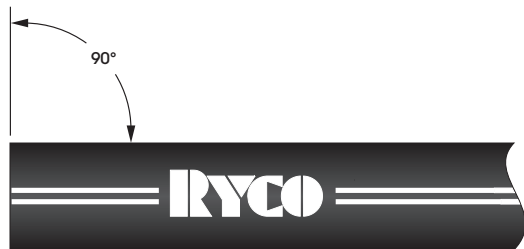

- Cut hose to length required using a cut-off saw.
- Ensure hose is cut squarely.
- Clean hose bore.

#### STEP TWO

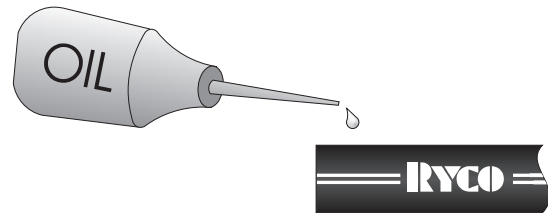

- Lightly lubricate outer cover.

#### STEP THREE

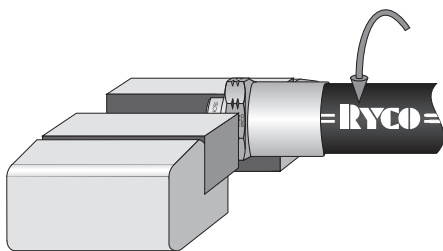

- Screw anti-clockwise until hose bottoms in ferrule.
- Ease back between 1/2 and 3/4 of a turn (Note: This is not required for P00-02 ferrule with TPGL hose).

#### STEP FOUR

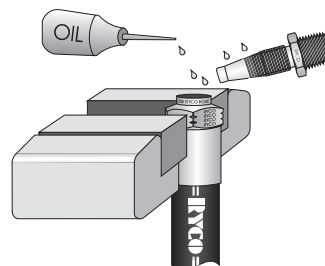

- Lightly lubricate insert and inside of hose.
- **Note: Do not use lubricant for M2G hose, or hose to be used with volatile gases.**

#### STEP FIVE

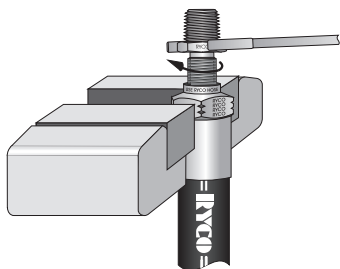

- Screw insert clockwise right into ferrule using a continuous motion.
- Do not allow hose to turn during operation.

#### SPECIAL NOTES

- **FOR T1D HOSE IN SIZES -20, -24, -32.** In these sizes, K Series Ferrules are not available and A Series Field Attachable Couplings may be used. The cover of hose must be skived at ends. Refer to page 477 for assembly instructions.
- **FOR T2D AND RQP2 HOSE IN SIZES -24, -32.** In these sizes, L Series Ferrules are not available and B Series Field Attachable Couplings may be used. The cover of hose must be skived at ends. Refer to page 477 for assembly instructions.
- **FIELD ATTACHABLE COUPLINGS** should not be used at maximum working pressure of hose when temperature exceeds 121°C (250°F). Field Attachable Couplings may be used on suitable hose at over 121°C (250°F) but at reduced working pressure. Contact RYCO Technical Department for more information.

## FIELD ATTACHABLE SKIVE HOSE ASSEMBLY

### ASSEMBLY INSTRUCTIONS FOR:

RYCO FIELD ATTACHABLE COUPLINGS WITH MATCHED SIZES OF RYCO SKIVE HOSE.  
USE ON LARGER SIZES OF RYCO T1D, T2D and RQP2 HOSE, SEE NOTE 1 & 2 on page 476).

INTRODUCTION

HOSE

COUPLINGS

ADAPTORS

TECHNICAL

#### STEP ONE



- Cut hose to length required using a cut-off saw.
- Ensure hose is cut squarely.
- Clean hose bore.

#### STEP TWO

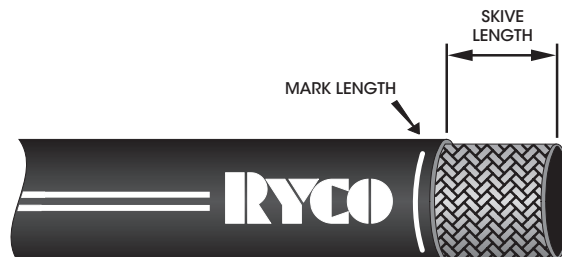

- Mark Skive Length (refer to Hose specification pages).
- Cut rubber cover around and down to wire reinforcement then slit lengthwise.
- Raise flap and pull off with pliers.

#### STEP THREE

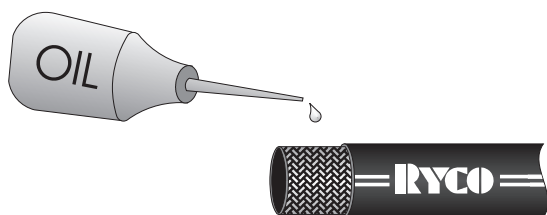

- Lightly lubricate exposed wire reinforcement.

#### STEP FOUR

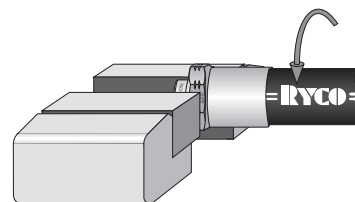

- Screw anti-clockwise until hose bottoms in ferrule.
- Ease back between 1/2 and 3/4 of a turn.

#### STEP FIVE

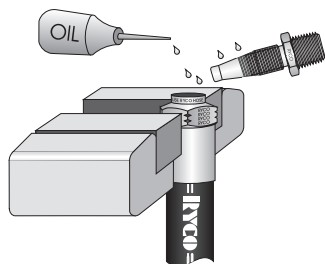

- Lightly lubricate insert and inside of hose.
- **Note: Do not use lubricant for hose to be used with volatile gases.**

#### STEP SIX

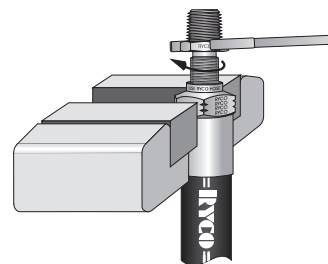

- Screw insert clockwise right into ferrule using a continuous motion.
- Do not allow hose to turn during operation.

### ASSEMBLY INSTRUCTIONS FOR:

#### 1. RYCO T2000, T6000 and T7000 SERIES COUPLINGS WITH RYCO NON-SKIVE HOSE.

USE ONLY MATCHED SIZES OF RYCO T3000D, T3000S, T4000D, T4000S, T5000D, T5000S, T6000D, T6000S, H3000D, H3000S, H4000D, H4000S, H5000D, H5000S, H6000D, H6000S, T2C, T1D, T2D, TJ2D, TXA2D, T1F, T1S, T2S, BT1, DF2D, D2B, RQP1, RQP2, H12D, H12S, MS1000, CS1000 (SKIVE), R4SH, TP7, TP7N, TP7T, TP7TN, TP8, TP8N, TP8T and TP8TN SERIES HOSE.

#### 2. RYCO T4000 and TG000 SERIES COUPLINGS WITH RYCO NON-SKIVE HOSE.

USE ONLY MATCHED SIZES OF RYCO M2, M2G, MP1, PL1, PL1D, RQP5, RQP6, TP7, TP7N, TP7T, TP7TN, TP3000, SRX, SRF,T5 and TPGL SERIES HOSE. (See page 483 for instructions for separating of ends of TP7T, TP7TN, TP8T and TP8TN Series.)

### STEP ONE

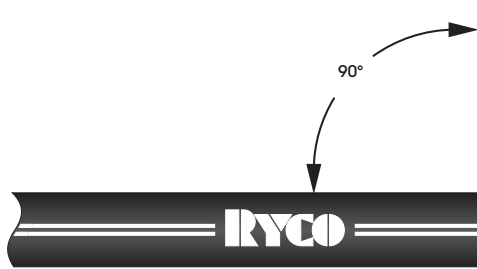

- Cut hose to required length using a cut-off saw.
- Ensure hose is cut squarely.
- Clean hose bore.

### STEP TWO

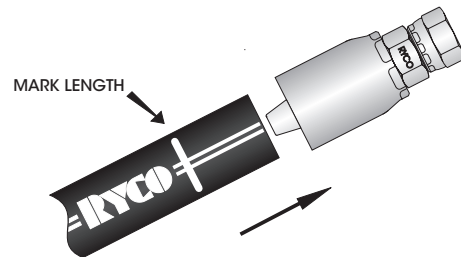

- Mark the Mark Length onto the hose (Mark Length dimension from "RYCO Crimp Chart").
- Push hose into the fitting (lightly lubricate the hose bore only if necessary as excess lubrication may reduce hose assembly impulse life) until the mark on the hose is even with the end of the ferrule\*.
- **Note: Push the hose all the way into the fitting.**

### STEP THREE

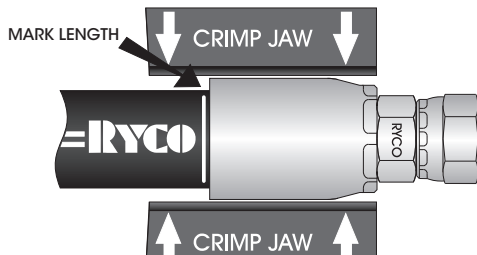

- Place assembled end into the jaws of crimp machine.
- Operate machine to crimp ferrule to predetermined diameter. (Refer to "RYCO Crimp Chart").

### STEP FOUR

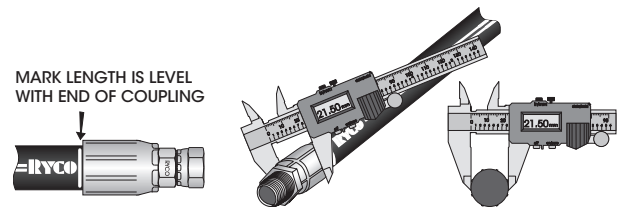

- Open the crimp machine and remove the assembly.
- Check the crimp diameter with a caliper or micrometer. Crimp diameter should be measured halfway along ferrule. Measure between the ridges, and make sure that the caliper fingers do not touch the ridges.
- Check that the Mark Length mark is still visible and even with the end of the ferrule to ensure coupling has not moved during crimping.

### NOTES

- **Extra special care must be exercised in the preparation, assembly and crimping of these fittings due to the very high pressures and end loads encountered.**
- **RYCO Crimp Chart detailing Mark or Skive Length and Crimp Diameter is available from RYCO Hydraulics.**
- **Note: Do not use lubricant for M2G hose, or hose to be used with volatile gases.**

\* For TP7, TP7N, TP7T, TP7TN, TP8, TP8N, TP8T, TP8TN, TP3000 and TPGL Hose Series it is preferable to lightly lubricate using a PTFE or Silicon-based aerosol spray lubricant. Use lubricant only if necessary; use sparingly if required.

### HOW TO ORDER BITELOK NON-SKIVE HOSE COUPLINGS

- The RYCO BITELOK Non-Skive Coupling is a one-piece fitting. BITELOK Non-Skive Couplings do not require the hose to be skived externally or internally.
- As the BITELOK Non-Skive Coupling is a complete coupling, simply order by Part Number.



## ASSEMBLY INSTRUCTIONS FOR:

RYCO T7000 SERIES COUPLINGS WITH RYCO SKIVE HOSE.  
USE ONLY MATCHED SIZES OF RYCO R4SP SERIES HOSE.

INTRODUCTION

HOSE

COUPLINGS

ADAPTORS

TECHNICAL

### STEP ONE

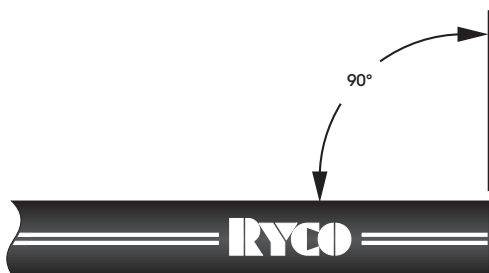

- Cut hose to length required using a cut-off saw.
- Ensure hose is cut squarely.
- Clean hose bore.

### STEP TWO

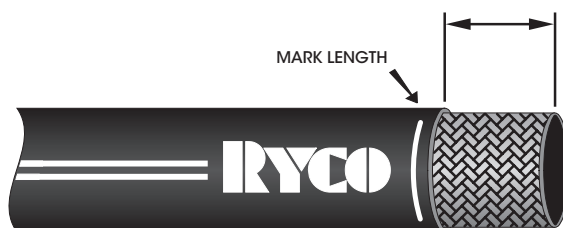

- Mark the Skive Length onto the hose. (Refer to "RYCO Crimp Chart").
- Cut rubber cover around and down to wire reinforcement then slit lengthwise.
- Raise flap and pull off with pliers.
- Measure coupling insertion depth and add a Mark Length Line on the outer cover as shown.

### STEP THREE

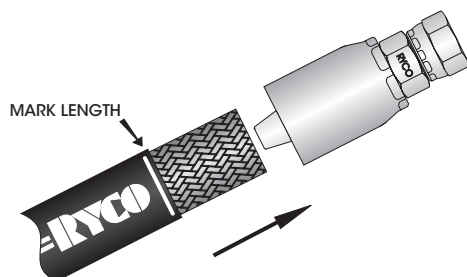

- Push hose into the fitting (lightly lubricate the hose bore only if necessary as excess lubrication may reduce hose assembly impulse life) until the mark on the hose is even with the end of the ferrule.
- **Note: Push the hose all the way into the fitting.**
- **Note: Do not use lubricant for hose to be used with volatile gases.**

### STEP FOUR

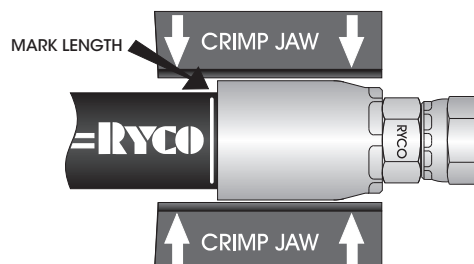

- Place assembled end into jaws of crimp machine.
- Operate machine to crimp ferrule to predetermined diameter. (Refer to "RYCO Crimp Chart").

### STEP FIVE

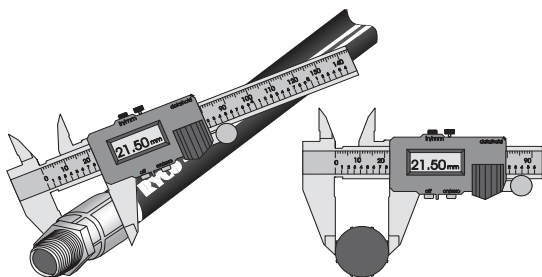

- Open crimp machine and remove assembly.
- Check crimp diameter with caliper or micrometer. Crimp diameter should be measured halfway along the ferrule. Measure between the ridges, and make sure that the caliper fingers do not touch the ridges.
- Check that the ferrule still completely covers the skived part of the hose to ensure coupling has not moved during crimping.

### NOTE

- Extra special care must be exercised in the preparation, assembly and crimping of these fittings due to the very high pressures and end loads encountered.
- The latest RYCO Crimp Chart detailing Mark or Skive Length and Crimp Diameter is available from the RYCO website.

### ASSEMBLY INSTRUCTIONS FOR:

TT000 SERIES ONE-PIECE COUPLINGS. USE ONLY MATCHED SERIES OF RYCO RTH1 SERIES HOSE.

#### STEP ONE

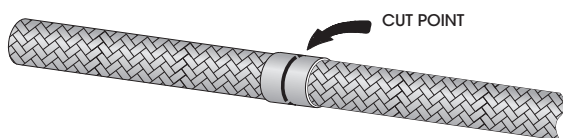

- Tape with masking tape at the cut position to prevent wire braid flaring.

#### STEP TWO

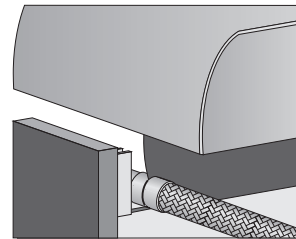

- Cut hose to length. Ensure hose is cut squarely.
- Clean hose bore.
- **WARNING: Do not smoke in the vicinity when cutting RTH1 hoses because fumes created are toxic and may mix with cigarette smoke when inhaled.**

#### STEP THREE

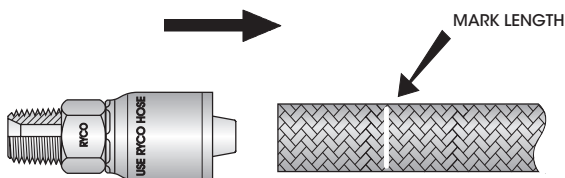

- Refer to "RYCO Crimp Chart" for Mark Length of Coupling.
- Mark outer cover with Mark Length.
- Push hose into the fitting (lightly lubricate the hose bore only if necessary as excess lubrication may reduce hose assembly impulse life) until the mark on the hose is even with the end of the ferrule\*.
- **Note: Push the hose all the way into the fitting.**

#### STEP FOUR

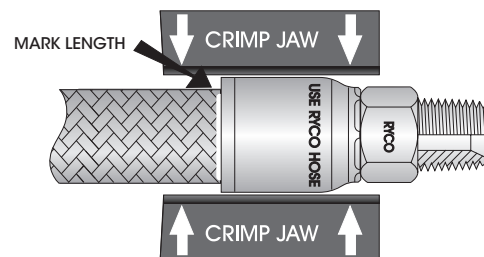

- Place assembled end into the jaws of crimp machine.
- Operate machine to crimp ferrule to predetermined diameter. (Refer to "RYCO Crimp Chart").
- Open the crimp machine.
- Check that the Mark Length mark is still visible and even with the end of the ferrule to ensure coupling has not moved during crimping.

#### STEP FIVE

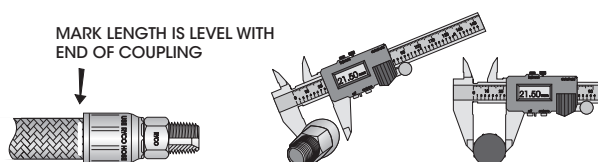

- Check that full length of ferrule has been crimped.
- Check the crimp diameter with a caliper or micrometer. Crimp diameter should be measured halfway along ferrule. Measure between the ridges, and make sure that the caliper fingers do not touch ridges.

#### NOTE

- **Extra special care must be exercised in the preparation, assembly and crimping of these fittings due to the very high pressures and end loads encountered.**
- **The latest RYCO Crimp Chart detailing Mark or Skive Length and Crimp Diameter is available from the RYCO website.**
- **Note: Do not use lubricant for hose to be used with volatile gases.**

## ASSEMBLY INSTRUCTIONS FOR:

33000 SERIES SUCTION HOSE COUPLINGS. Use only MATCHED SERIES OF RYCO SRX and SRF SERIES Hose.

INTRODUCTION

### STEP ONE

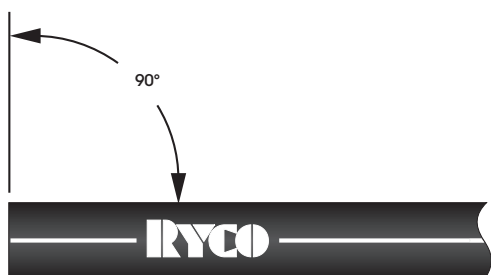

- Cut hose to required length using a cut-off saw.
- Ensure helix wires are not protruding.
- Ensure hose is cut squarely.

### STEP TWO

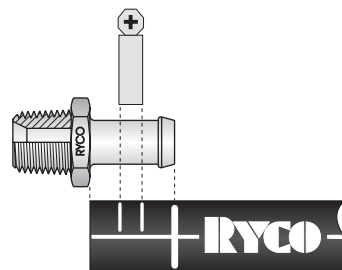

- Mark the cover of the hose to ensure that Clamp will be correctly located.

HOSE

COUPLINGS

### STEP THREE

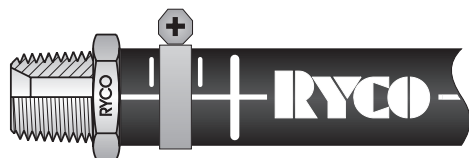

- Slide Clamp over hose.
- Push the coupling into the hose bore until hex or collar abuts end of hose.
- Position Clamp, and tighten bolt to recommended torque.

ADAPTORS

TECHNICAL

### ASSEMBLY INSTRUCTIONS FOR:

8000 SERIES PUSH-ON COUPLINGS. USE ONLY RYCO PL1D, PL1V and RQP6 SERIES HOSE.

#### STEP ONE

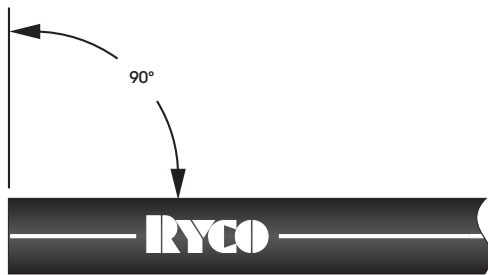

- Cut hose to required length with a sharp knife.
- Lightly lubricate inside of hose and outside of nipple.

#### STEP TWO

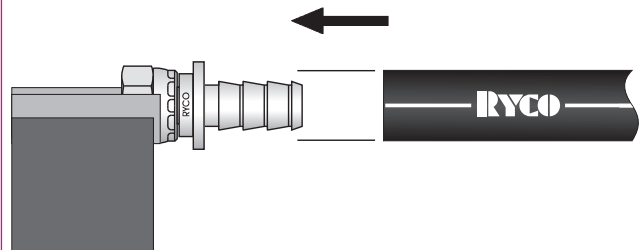

- Push hose onto fitting until hose end bottoms underneath cap as shown.

#### STEP THREE

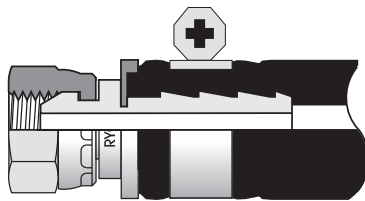

- If hose assembly is to be used at above 50% of Maximum Working Pressure, or in a potentially dangerous or critical application, a clamp must be used.
- Do not overtighten clamp as this may damage hose.

#### REMOVING COUPLINGS, STEP ONE

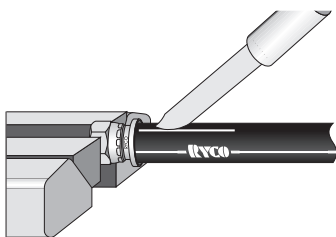

- Remove clamp if fitted.
- Slit hose length-wise, from cap to end of hose tail.

#### REMOVING COUPLINGS, STEP TWO

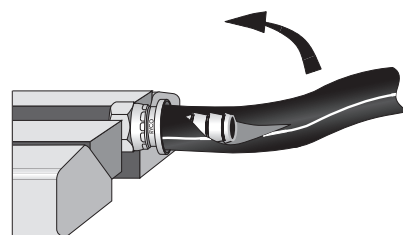

- Sharply bend hose and remove.

## ASSEMBLY INSTRUCTIONS – TP7T, TP7TN, TP8T AND TP8TN TWIN HOSE

### ASSEMBLY INSTRUCTIONS FOR:

SEPARATION OF THE ENDS OF TP7T, TP7TN, TP8T and TP8TN TWIN HOSE.

Note: RYCO TP7T, TP7TN, TP8T and TP8TN Hose must be separated at the ends to permit the attachment of the couplings. Procedure is as follows.

The latest RYCO Crimp Chart detailing Crimp Diameter and Mark Length is available from the RYCO website.

INTRODUCTION

HOSE

COUPLINGS

ADAPTORS

TECHNICAL

#### STEP ONE

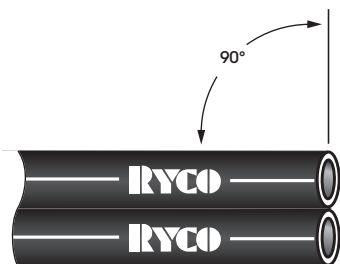

- Cut hose to length required using a sharp knife.
- Ensure hose is cut squarely.
- Clean hose bore.

#### STEP TWO

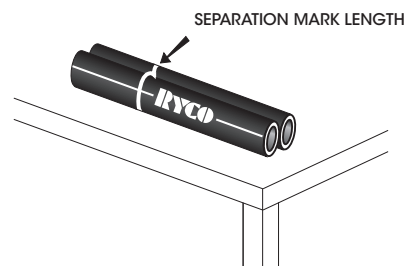

- Arrange the end of the twin line hose so that it is lying straight and flat, resting on the bottom of both hoses, on a horizontal work surface.
- Mark the length to be separated on the cover of the hoses.
- The separation length required may vary depending on the crimper being used.
- Separation length must allow each hose end to be inserted into the crimper without kinking the other hose.

#### STEP THREE

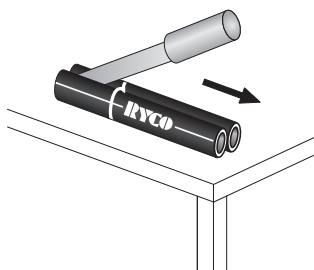

- Hold the hoses flat on the work bench, and lightly score along the joint between the two hoses with a blunt knife.
- Keep the knife vertical to avoid cover damage. It may be necessary to score along the joint several times.
- Take care not to damage the covers of the hoses.
- Turn the hose over and repeat the above to score the other side of the joint.
- The hoses will now be able to be separated by pulling apart.
- Inspect the covers to ensure there is no damage, if the cover is cut or the reinforcement is exposed, the hoses must not be used.

#### STEP FOUR, FIVE, SIX

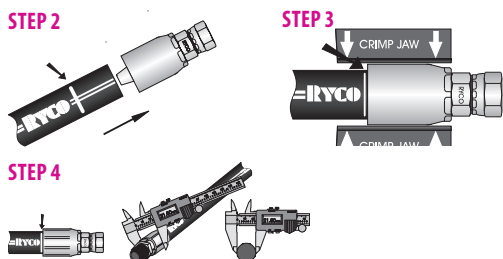

- Follow Step Two, Three and Four of page 489 (Non-Skive Hose Assembly) for each end of the hose.

#### STEP SEVEN



- After crimping the couplings, the hoses can be tied together at the separation area with tape or a cable tie to prevent the hoses becoming further separated accidentally.

# TECHNICAL

## TUBE FLARING DIMENSIONS – 37° JIC AND 45° SAE

### RYCO S6, S6M, S6S AND SA6 TUBE NUTS AND SLEEVES ARE FOR USE WITH FLARED STEEL HYDRAULIC TUBING.

Dimensions for flares shown below are as specified in SAE J533 "Flares for Tubing".

Tubing must be flared to the correct dimensions. Flares must be free from loose scale, burrs, slivers, and cracks. Seating surfaces must be smooth and free from nicks, pit marks, and any other defects that prevent sealing. The flare seat must be concentric with the tube outside diameter within 0,38 mm (.015") Full Indicator Reading (FIR). Smoothly breaking (radiusing) the outside corner of the tube prior to single flaring, to minimise splitting, is permissible.

For S6, S6S and SA6 for Imperial Outside Diameter Tubing, use only seamless annealed hydraulic tubing to ASTM A179 of wall thickness no greater than that specified in the tables.

For S6M for Metric Outside Diameter Tubing, use only seamless annealed hydraulic tubing of wall thickness no greater than that specified in the tables.

Tubing may be double flared for thin wall thicknesses, or single flared for thicker walled tubing. Dimensions below are for single flared tubing.

Recommended maximum wall thickness of tubing specified in tables is the thickest tubing normally considered suitable for flaring. Optional configurations to provide extended length of seal contact surface for tube wall thickness exceeding the limits in the tables, are also specified in SAE J533.

### S6 AND S6S SERIES FOR IMPERIAL OD TUBING WITH JIC 37° FLARE

RYCO S6	RYCO S6S	NOMINAL TUBE OD		MAXIMUM WALL THICKNESS D		MAXIMUM FLARE DIAMETER A		MINIMUM FLARE DIAMETER A		FLARE RADIUS ± 0,25 mm (± 0.01") R	
		mm	inch	mm	inch	mm	inch	mm	inch	mm	inch
PART NO	PART NO										
S6-0502		3,18	0.13	0,89	0.04	5,1	0.20	4,6	0.18	0,80	0.03
S6-0603		4,76	0.19	0,89	0.04	7,1	0.28	6,6	0.26	0,80	0.03
S6-0704		6,35	0.25	1,65	0.06	9,1	0.36	8,6	0.34	0,80	0.03
S6-0805		7,94	0.31	1,65	0.06	10,9	0.43	10,2	0.40	0,80	0.03
S6-0906	S6S-0906	9,52	0.37	1,65	0.06	12,4	0.49	11,7	0.46	1,00	0.04
S6-1208	S6S-1208	12,70	0.50	2,11	0.08	16,8	0.66	16,0	0.63	1,50	0.06
S6-1410	S6S-1410	15,88	0.63	2,41	0.09	20,1	0.79	19,3	0.76	1,50	0.06
S6-1712		19,05	0.75	2,77	0.11	24,1	0.95	23,4	0.92	2,00	0.08
S6-1914		22,22	0.87	2,77	0.11	27,2	1.07	26,4	1.04	2,00	0.08
S6-2116		25,40	1.00	3,05	0.12	30,5	1.20	29,7	1.17	2,30	0.09
S6-2620		31,75	1.25	3,05	0.12	38,4	1.51	37,6	1.48	2,30	0.09
S6-3024		38,1	1.50	3,05	0.12	43,9	1.73	43,2	1.70	2,80	0.11
S6-4032		50,8	2.00	3,40	0.13	59,9	2.36	59,2	2.33	2,80	0.11

## TUBE FLARING DIMENSIONS – 37° JIC AND 45° SAE

### S6M SERIES FOR METRIC OD TUBING WITH JIC 37° FLARE

RYCO S6M	NOMINAL TUBE OD		MAXIMUM WALL THICKNESS D		MAXIMUM FLARE DIAMETER A		MINIMUM FLARE DIAMETER A		FLARE RADIUS ± 0,25 mm (± 0.01") R	
	mm	inch	mm	inch	mm	inch	mm	inch	mm	inch
S6M-0503	3,00	0.12	0,89	0.04	5,1	0.20	4,6	0.18	0,80	0.03
S6M-0605	5,00	0.20	0,89	0.04	7,1	0.28	6,6	0.26	0,80	0.03
S6M-0706	6,00	0.24	1,65	0.06	9,1	0.36	8,6	0.34	0,80	0.03
S6M-0808	8,00	0.31	1,65	0.06	10,9	0.43	10,2	0.40	0,80	0.03
S6M-0910	10,00	0.39	1,65	0.06	12,4	0.49	11,7	0.46	1,00	0.04
S6M-1212	12,00	0.47	2,11	0.08	16,8	0.66	16,0	0.63	1,50	0.06
S6M-1416	16,00	0.63	2,41	0.09	20,1	0.79	19,3	0.76	1,50	0.06
S6M-1719	19,00	0.75	2,77	0.11	24,1	0.95	23,4	0.92	2,00	0.08
S6M-1920	20,00	0.79	2,77	0.11	27,2	1.07	26,4	1.04	2,00	0.08
S6M-2125	25,00	0.98	3,05	0.12	30,5	1.20	29,7	1.17	2,30	0.09
S6M-2632	32,00	1.26	3,05	0.12	38,4	1.51	37,6	1.48	2,30	0.09
S6M-3038	38,00	1.50	3,05	0.12	43,9	1.73	43,2	1.70	2,80	0.11
S6M-4051	51,00	2.01	3,40	0.13	59,9	2.36	59,2	2.33	2,80	0.11

### SA6 SERIES FOR IMPERIAL OD TUBING WITH SAE 45° FLARE

RYCO SA6	NOMINAL TUBE OD		MAXIMUM WALL THICKNESS D		MAXIMUM FLARE DIAMETER A		MINIMUM FLARE DIAMETER A		FLARE RADIUS ± 0,25 mm (± 0.01") R	
	mm	inch	mm	inch	mm	inch	mm	inch	mm	inch
SA6-1006	9,52	0.38	1,65	0.06	12,4	0.49	12,0	0.47	0,50	0.02
SA6-1712	19,05	0.75	2,77	0.11	23,3	0.92	22,9	0.90	0,50	0.02

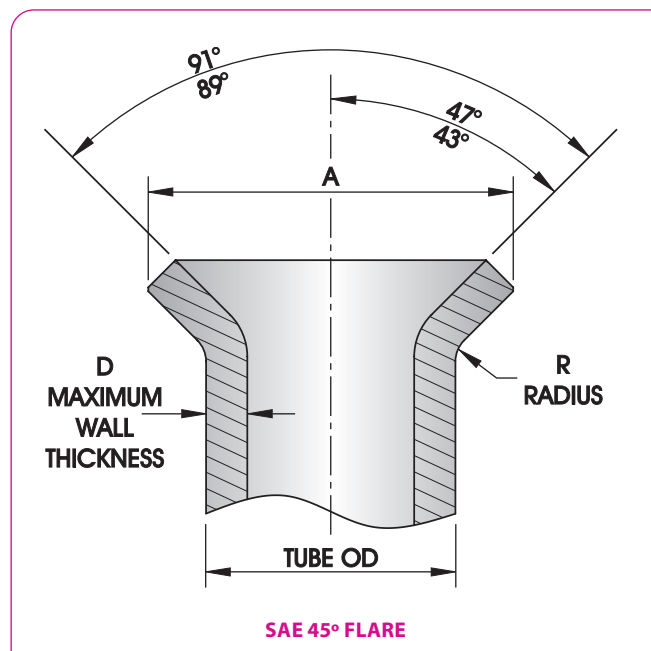
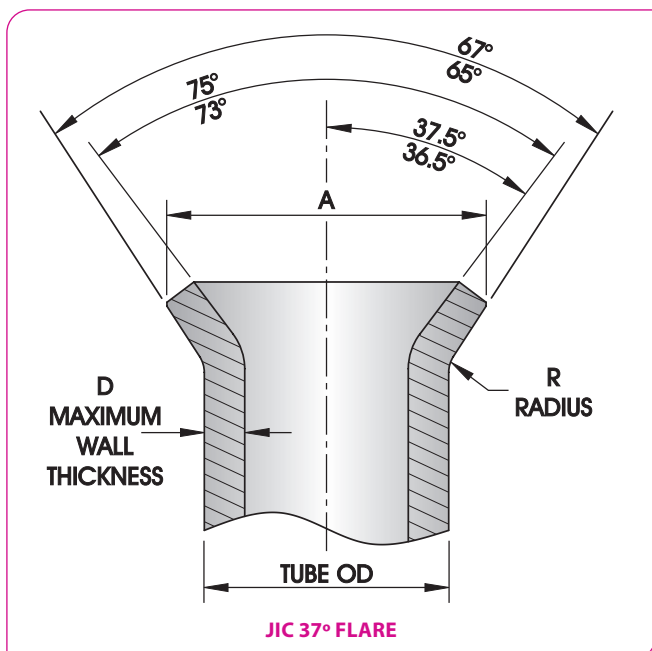

INTRODUCTION

HOSE

COUPLINGS

ADAPTORS

TECHNICAL



### ASSEMBLY INSTRUCTIONS FOR:

TUBE BITE HOSE COUPLINGS (END STYLE 850).

RYCO Hose Couplings Series with Tube Bite End Style 850 (T2850, T4850 and 6850 Series) provide a quick and convenient method of connecting Imperial Outside Diameter seamless steel hydraulic tubing, without the need to flare the tubing.

They allow quick and economical repairs to assemblies made of combined hose and Imperial-sized tubing. Often in these assemblies, the tubing is bent to a special shape or includes special mounting brackets, and is difficult or expensive to replace.

#### STEP ONE



- Ensure that the wall thickness of the tubing is of the approved gauge. See S134 J-Lok & Tubing Selection Table page <?>.
- Cut the tube to required length. Ensure that the tube is cut squarely. A tube cutter is preferred, however a hacksaw or abrasive drop saw may be used providing the cut is square and clean.
- Deburr inner and outer edges of tube.

#### STEP TWO

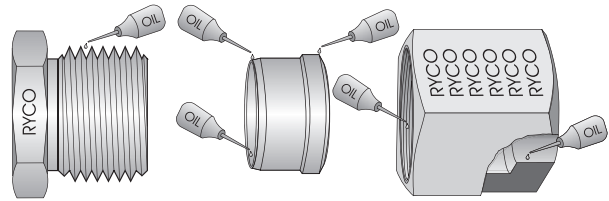

- Remove dirt, grit and cutting debris from the inside and outside of the tube.
- Remove the Nut and Compression Olive from the T2850, T4850 or 6850 coupling.
- Lubricate the threads of the Nut and the Male Thread of the T2850, T4850 or 6850 coupling with assembly oil or hydraulic oil.
- Lubricate internal and external surfaces of the Compression Olive with assembly oil or hydraulic oil.

#### STEP THREE

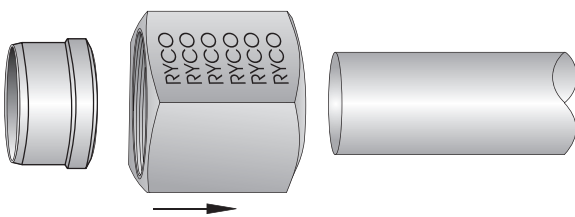

- Slide the Nut onto the tube, so that the threads of the Nut face towards the end of the tube to be assembled to the coupling, then slide the Compression Olive onto the tube.
- The end with the raised collar must be adjacent to the Nut, and the end with the long parallel section must face towards the end of the tube to be assembled to the coupling.

#### STEP FOUR

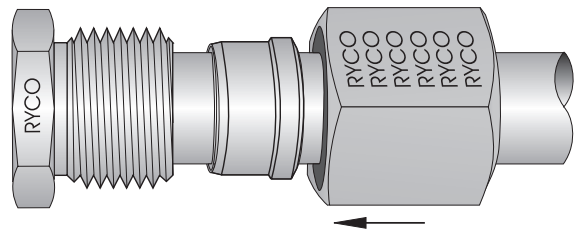

- Insert the tube end into the Male Threaded end of the T2850, T4850 or 6850 coupling, until it bottoms against the shoulder inside the Male Threaded end.
- Slide the Nut and Compression Olive along the tube until the Compression Olive seats inside the coupling body, and thread the Nut onto the Male Threaded end of the coupling.
- Tighten Nut until the Compression Olive just grips the tube. The initial gripping of the tube is complete when the tube can no longer be rotated by hand.

#### STEP FIVE

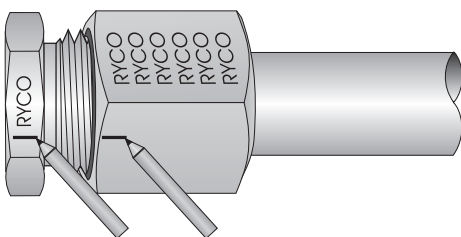

- Place a mark on the Nut, and an adjacent mark on the Hex of the T2850, T4850 or 6850 coupling insert.

#### STEP SIX

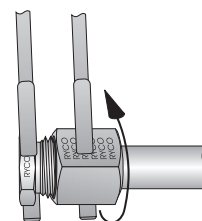

- Holding the hex of the T2850, T4850 or 6850 coupling insert stationary with one spanner, with another spanner tighten the Nut down by one full turn, to compress the Olive onto the tube<sup>1</sup>.
- Use the marks from Step 5 as a reference. Ensure that the tube end is firmly butted against the shoulder inside the coupling, and that the tube does not rotate<sup>2</sup>.

## ASSEMBLY INSTRUCTIONS – TUBE BITE HOSE COUPLINGS (END STYLE 850)

### ASSEMBLY INSTRUCTIONS FOR:

TUBE BITE HOSE COUPLINGS (END STYLE 850) CONT.

If safe to do so, the bent tube part can be cut from the old assembly and reused. (NOTE: for combined hose and tubing assemblies with Metric Tubing, Male DKL or DKS Hose Coupling can be used with M6L or M6S Metric Nut and Cutting Ring).

INTRODUCTION

#### STEP SEVEN

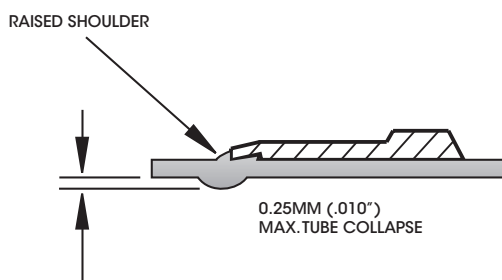

- Disassemble the Nut from the Coupling.
- Inspect the front edge of the Compression Olive. For correct assembly, the cutting edge of the Compression Olive must have formed a shoulder on the tube at least 50% as high as the cutting edge, all the way around the tube.

#### STEP EIGHT

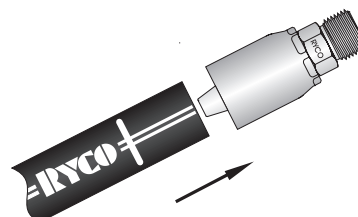

- Attach the T2850, T4850 or 6850 coupling onto the hose, without the tube, Nut and Compression Olive connected to it.
- Refer to the appropriate Assembly Instructions for the Hose Series and Coupling Series being assembled.
- Do not assemble the coupling onto the hose until Steps One to Seven are completed.

HOSE

COUPLINGS

#### STEP NINE

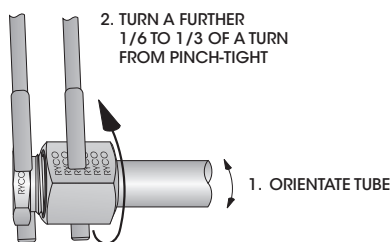

- Re-assemble the tube, Nut and Compression Olive onto the T2850, T4850 or 6850 end of the hose assembly.
- Nut will turn easily until an increase in force is required. At this point, orient the bent tube assembly pointing to the correct direction if required.
- Holding the Hex of the T285, T485 or 685 coupling insert with one spanner, with another spanner tighten the Nut down a further 1/6 of a turn as a minimum, but no more than 1/3 of a turn, to complete tightening operation.

#### NOTES

- 1 This is a general rule, and may vary slightly with different tubing materials.
- 2 In some instances (especially when using soft or thin-walled tube), to prevent excessive tube collapse, it may be necessary to support the inside of the tube with a mandrel prior to setting the Compression Olive.
- 3 Note that the maximum allowable radial collapse of the inner tube diameter is 0,25 mm (.010").

ADAPTORS

TECHNICAL

### ASSEMBLY INSTRUCTIONS FOR:

S134 Series J-Lok Flareless Tube Fittings.

RYCO S134 J-Lok Flareless Tube Fittings provide a quick and convenient method of connecting Imperial Outside Diameter seamless steel hydraulic tubing to RYCO JIC male threads with 37° seat, without the need to flare the tubing. The wall thickness of the tubing must be of the approved gauge (see page 489 for Selection Table).

#### STEP ONE

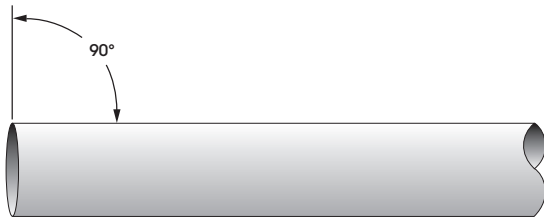

- Ensure that the wall thickness of the tubing is of the approved gauge. See S134 J-Lok & Tubing Selection Table on page <?>.
- Cut the tube to required length. Ensure that the tube is cut squarely. A tube cutter is preferred, however a hacksaw or abrasive drop saw may be used providing the cut is square and clean.
- Deburr inner and outer edges of tube.

#### STEP TWO

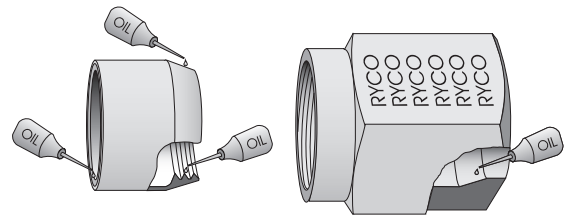

- Remove dirt, grit and cutting debris from the inside and outside of the tube.
- Lubricate the mating surfaces of the S134 J-Lok Flareless Olive and Nut with assembly oil or hydraulic oil.
- Ensure that the teeth inside the Flareless Olive are well lubricated.

#### STEP THREE

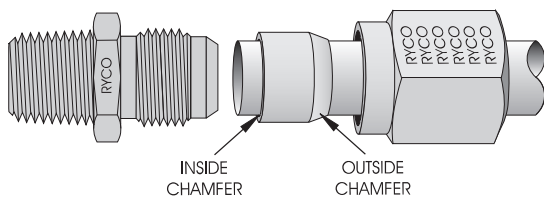

- Slide the S134 Nut on to the tube, so that the thread of the Nut faces towards the end of the tube.
- Then slide the S134 Flareless Olive onto the tube. The outside chamfered end must be adjacent to the S134 Nut, and the inside chamfered end must face towards the end of the tube.

#### STEP FOUR

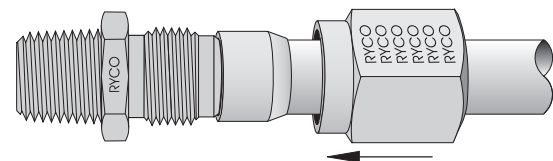

- Butt the tube end against the JIC male seat.
- With the tube held against the JIC male seat, slide the S134 Nut and Flareless Olive along the tube, until the Flareless Olive mates with the JIC male seat, and the S134 Nut mates with the JIC male thread.

#### STEP FIVE

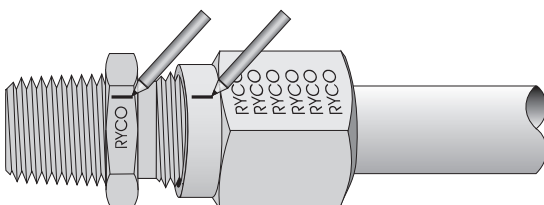

- Engage the thread of the S134 Nut with the mating JIC male thread, while holding the tube against the JIC male seat. Prevent the tube from rotating.
- When the S134 Nut cannot be further tightened by hand onto the JIC male thread, place a mark on collar of the S134 Nut, and an adjacent mark on the JIC male hex.

#### STEP SIX

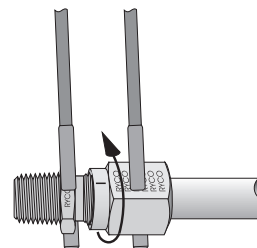

- Hold the JIC male hex stationary and further tighten the S134 Nut by spanner, rotating it 1¼ turns.
- Use the marks from STEP 5 as a reference.
- Ensure the tube is always held against the JIC male seat and prevent the tube from rotating.

## ASSEMBLY INSTRUCTIONS – S134 J-LOK FLARELESS TUBE FITTINGS

### ASSEMBLY INSTRUCTIONS FOR:

S134 Series J-Lok Flareless Tube Fittings. Cont.

RYCO S134 J-Lok Flareless Tube Fittings provide a quick and convenient method of connecting Imperial Outside Diameter seamless steel hydraulic tubing to RYCO JIC male threads with 37° seat, without the need to flare the tubing. The wall thickness of the tubing must be of the approved gauge (see page 489 for Selection Table).

INTRODUCTION

### STEP SEVEN

- **If the connection is to be undone and then reassembled:**
- First tighten the S134 Nut onto the JIC male thread by hand.
- When the S134 Nut cannot be further hand tightened, tighten it with a spanner one more hex flat (1/6 of a turn).
- RYCO S134 J-Loks may be reassembled in this manner approximately ten times.

HOSE

COUPLINGS

### SELECTION TABLE FOR S134 J-LOK FITTINGS AND TUBING

TUBING USED MUST BE IMPERIAL OUTSIDE DIAMETER SEAMLESS ANNEALED STEEL HYDRAULIC TUBING TO ASTM A179.

RYCO S134 J-LOK	TUBE OD X GAUGE	TUBE DIMENSIONS (INCH)			TUBE DIMENSIONS (MM)			MAXIMUM DYNAMIC WORKING PRESSURE	
		OUTSIDE DIAMETER	WALL THICKNESS	INSIDE DIAMETER	OUTSIDE DIAMETER	WALL THICKNESS	INSIDE DIAMETER	bar	psi
PART NO		inch	inch	inch	mm	mm	mm	bar	psi
<b>S134-0704</b>	1/4 x 20G	0.250	0.035	0.180	6,35	0,91	4,53	238	3450
<b>S134-0906</b>	3/8 x 18G	0.375	0.049	0.277	9,53	1,22	7,09	252	3650
<b>S134-0906</b>	3/8 x 16G	0.375	0.065	0.245	9,53	1,63	6,27	310	4500
<b>S134-1208</b>	1/2 x 18G	0.500	0.049	0.402	12,70	1,22	10,26	183	2650
<b>S134-1208</b>	1/2 x 16G	0.500	0.065	0.370	12,70	1,63	9,44	252	3650
<b>S134-1410</b>	5/8 x 16G	0.625	0.065	0.495	15,88	1,63	12,62	197	2850
<b>S134-1410</b>	5/8 x 14G	0.625	0.080	0.465	15,88	2,03	11,82	207	3000
<b>S134-1712</b>	3/4 x 16G	0.750	0.065	0.620	19,05	1,63	15,79	162	2350
<b>S134-1712</b>	3/4 x 14G	0.750	0.080	0.590	19,05	2,03	14,99	207	3000
<b>S134-2116</b>	1 x 14G	1.000	0.080	0.840	25,40	2,03	21,34	152	2200
<b>S134-2116</b>	1 x 12G	1.000	0.104	0.792	25,40	2,64	20,12	193	2800

ADAPTORS

TECHNICAL

### INSTALLATION GUIDE - HOSE ASSEMBLY

Proper hose installation is essential for satisfactory performance. If hose length is excessive, the appearance of the installation will be unsatisfactory and unnecessary cost of equipment will be involved. If hose assemblies are too short to permit adequate flexing and changes in length due to expansion or contraction, hose service life will be reduced.

The following diagrams show proper hose installations which provide maximum performance and cost savings. Consider these examples in determining length of a specific assembly.

#### STRAIGHT HOSE INSTALLATIONS

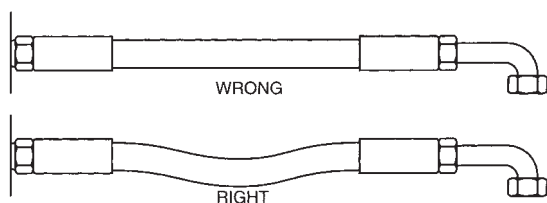

- When hose installation is straight, allow enough slack in hose line to provide for length changes that will occur when pressure is applied.

#### FLEXING APPLICATIONS

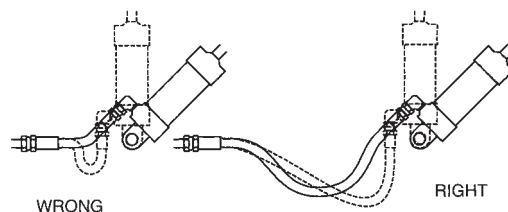

- Adequate hose length is necessary to distribute movement on flexing applications, and to avoid abrasion.

#### TWISTS AND BENDS, PART ONE

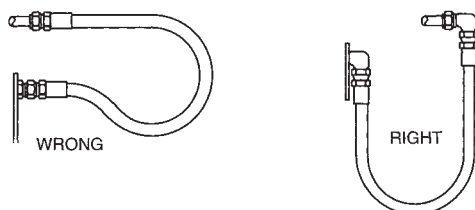

- When radius is below the required minimum, use an angle adaptor to avoid sharp bends.

#### TWISTS AND BENDS, PART TWO

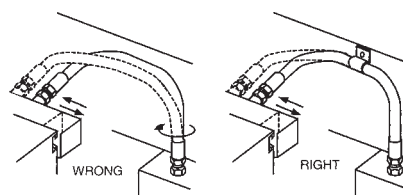

- Avoid twisting of hose lines bent in two planes by clamping hose at change of plane.

#### TWISTS AND BENDS, PART THREE

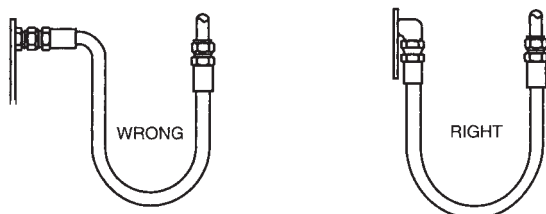

- Use proper angle adaptors to avoid sharp twists or bends in the hose.

#### TWISTS AND BENDS, PART FOUR

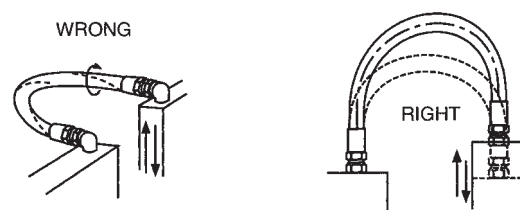

- Prevent twisting and distortion by bending hose in same plane as the motion of the boss to which hose is connected.

## INSTALLATION GUIDE - HOSE ASSEMBLY (CONT)

Proper hose installation is essential for satisfactory performance. If hose length is excessive, the appearance of the installation will be unsatisfactory and unnecessary cost of equipment will be involved. If hose assemblies are too short to permit adequate flexing and changes in length due to expansion or contraction, hose service life will be reduced.

The following diagrams show proper hose installations which provide maximum performance and cost savings. Consider these examples in determining length of a specific assembly.

INTRODUCTION

### REDUCE NUMBER OF PIPE FITTINGS



- Reduce number of pipe thread joints by using proper hydraulic adaptors instead of pipe fittings.

### USE 45° AND/OR 90° ADAPTORS

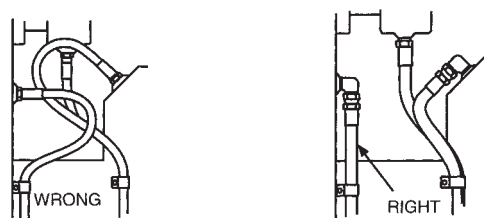

- Route hose directly by using 45° and/or 90° adaptors and fittings.
- Avoid excessive hose length to improve appearance.

HOSE

COUPLINGS

### ALLOWING FOR LENGTH CHANGE

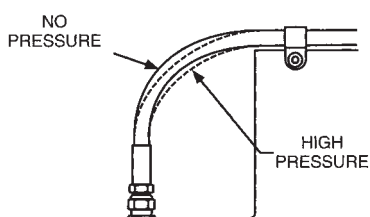

- To allow for length changes when hose is pressurised, do not clamp at bends.
- Curves will absorb changes.
- Do not clamp high and low pressure lines together.

### AVOID TWISTING HOSE

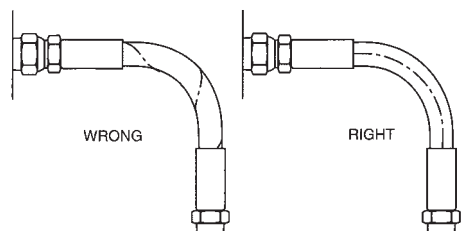

- When installing hose, make sure it is not twisted.
- Pressure applied to a twisted hose can result in hose failure or loosening of connections.

ADAPTORS

TECHNICAL

### HIGH TEMPERATURE

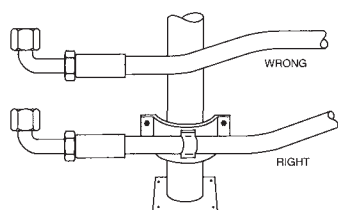

- High ambient temperatures shorten hose, therefore ensure hose is kept away from hot parts.
- If this is not possible, insulate hose.

### RELIEVE STRAIN

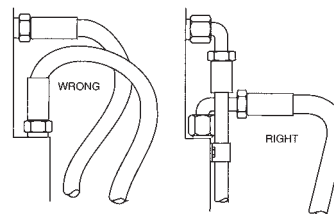

- Elbows and adaptors should be used to relieve strain on the assembly, and to provide neater installations which will be more accessible for inspection and maintenance.

### INSTALLATION GUIDE - HOSE ASSEMBLY (CONT)

Proper hose installation is essential for satisfactory performance. If hose length is excessive, the appearance of the installation will be unsatisfactory and unnecessary cost of equipment will be involved. If hose assemblies are too short to permit adequate flexing and changes in length due to expansion or contraction, hose service life will be reduced.

The following diagrams show proper hose installations which provide maximum performance and cost savings. Consider these examples in determining length of a specific assembly.

#### AVOID COLLAPSE AND RESTRICTION

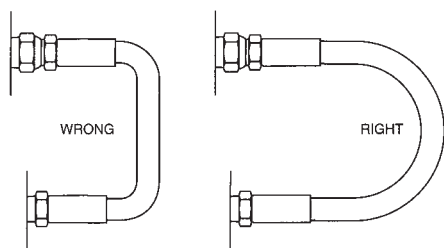

- To avoid hose collapse and flow restriction, keep hose bend radii as large as possible.
- Refer to hose specification tables for minimum bend radii.

#### AVOID ABRASION

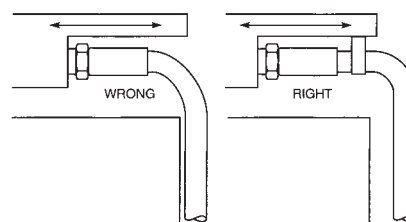

- Run hose in the installation so that it avoids rubbing and abrasion.
- Often, clamps are required to support long hose runs or to keep hose away from moving parts.
- Use clamps of the correct size. A clamp too large allows hose to move inside the clamp and causes abrasion.

#### NOTE

- When determining the length of hose assemblies, provide sufficient length to prevent bending strain from localising at the back of the coupling. In the 'TYPICAL DIMENSIONS FOR ONE & TWO WIRE BRAID HOSE' diagram below, measurement "B" allows for a strain section of hose beyond the coupling to prevent concentration of bending strain. "T" designates the amount of travel. "A" indicates the smallest diameter to which hose should be bent.
- **OVERALL LENGTH = B+1.57A+T**

### TYPICAL DIMENSIONS FOR ONE & TWO WIRE BRAID HOSE

HOSE SIZE			"B" CONSTANT FOR STRAIGHT PORTION INCLUDING COUPLING
DN	inch	Dash	
6	1/4	-04	250 mm (10")
10	3/8	-06	250 mm (10")
12	1/2	-08	300 mm (12)
19	3/4	-12	350 mm (14")
25	1	-16	400 mm (16")
31	1.1/4	-20	450 mm (28")
38	1.1/2	-24	500 mm (20")
51	2	-32	500 mm (20")

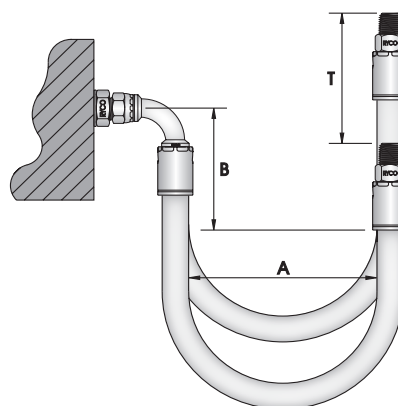



### FACTOR OF SAFETY (FOS)

Hydraulic Hose Assemblies have a rated maximum working pressure (MWP) of the lesser of the MWP of the hydraulic hose and the MWP of the connector terminations.

Hydraulic Hose has a finite life. The lifespan of Hydraulic Hose Assemblies is affected by many factors (see 'Hose Selection' and 'Safety Guide' pages 465 to 472, and RYCO HALP® program page 23). Three limiting factors are working pressure, temperature and impulse pressures (pulses). High Impulse Pressures will fatigue hydraulic hose and consume their life.

Fatigue life is specified by a logarithmic **P-N Curve**, where **P** = Pressure and **N** = Impulses.

Hydraulic hose assemblies require a FOS (Factor of Safety) of 4:1.

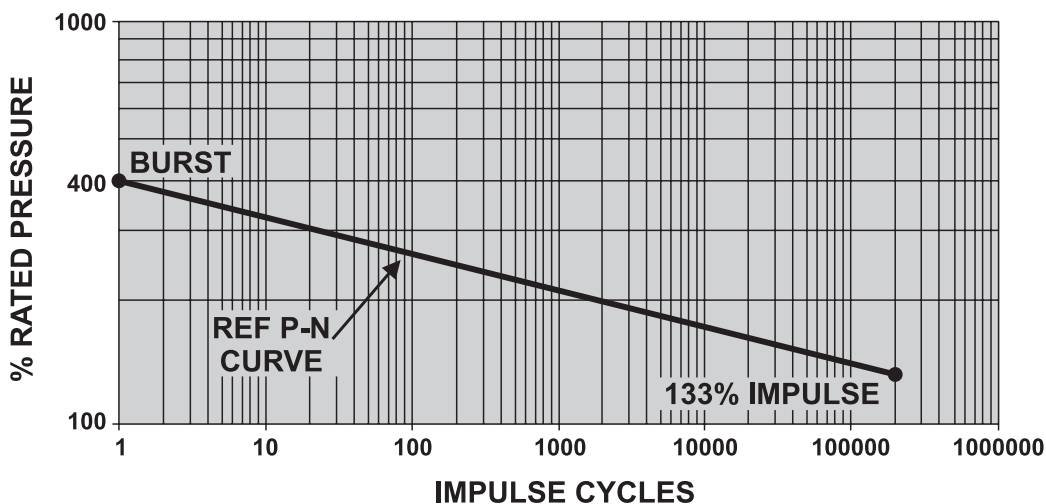

**IMPULSE CURVE FOR EN853-2SN (SAE 100R2AT)**

This implies that an unused hydraulic hose assembly has to be able reach four times its MWP (4 x MWP) once only (one pulse). Depending upon the specification requirements of the hydraulic hose, the Hydraulic Hose Assembly (be sure to use couplings that are MATCHED to the hose) must pass an Impulse Test (fatigue life test) at a specified percentage of the hose MWP for a specified number of pressure impulses. In the example above we see that EN853-2SN requires 200,000 impulses at 133% of its MWP (rated pressure). Impulse Tests are generally conducted with fluid heated to the maximum rated operating temperature of the hose.

RYCO Hydraulics Connector Terminations have a FOS of 4:1.

### FACTOR OF SAFETY (FOS) OF HOSE ASSEMBLY

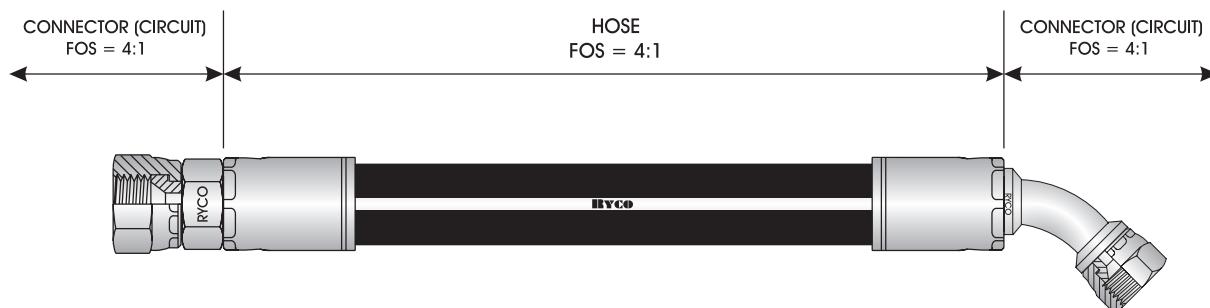

# TECHNICAL

## GUIDE TO THREAD AND CONNECTOR WORKING PRESSURES

### WORKING PRESSURES - ADAPTORS, HOSE COUPLINGS AND HOSE ASSEMBLIES.

Since many factors influence the pressure at which a hydraulic system will, or will not, perform satisfactorily, maximum working pressures listed below should be used as a guide only and not as a "standard" nor "specification", nor construed as a "guaranteed minimum." Within the fluid power industry, many criteria are used for the determination of pressure capability. Various fibre stresses, minimum yields and design factors are applied, commensurate with total system conditions. Thus, it is impractical to lay down specific allowable working pressures that satisfy all design criteria. Unless otherwise specified in this document, and given correct working conditions, including, but not limited to, torque setting, assembly, alignment, support, pressures (internal and external), temperature limits, environmental, installation, vibration free, damage free, chemical, cleanliness and regular maintenance and inspection, the following may be used as a guide to maximum working pressure. For further technical assistance contact RYCO Hydraulics Technical Department or your RYCO Hydraulics distributor.

**The Maximum Working Pressure of a Hose Assembly is the lesser rated Working Pressure of the Hose or Tube or End Style (Connector termination). The Maximum Rated Working Pressure of an Adaptor with a combination of Thread / End Styles and sizes, is the Maximum Working Pressure of the least rated end.**

BSP	BSPT MALE	BSPP MALE	BSPT MALE LIVE SWIVEL	BSPT FEMALE FIXED	BSPP FEMALE SWIVEL (CRIMP NUT)	BSPP FEMALE SWIVEL (WIRE NUT)	BSP FEMALE SWIVEL	BSPP MALE NON-ADJUSTABLE (O RING & RETAINING RING)
-----	-----------	-----------	-----------------------	-------------------	--------------------------------	-------------------------------	-------------------	--

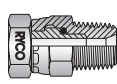

THREAD SIZE	DASH SIZE	MAX. WORKING PRESSURE															
		bar	psi	bar	psi	bar	psi	bar	psi	bar	psi	bar	psi	bar	psi	bar	psi
1/8	-02	690	10000	690	10000	420	6100	690	10000	690	10000			690	10000	350	5100
1/4	-04	690	10000	690	10000	420	6100	690	10000	690	10000			690	10000	350	5100
3/8	-06	690	10000	620	9000	420	6100	690	10000	620	9000			620	9000	350	5100
1/2	-08	690	10000	480	7000	350	5100	690	10000	480	7000			480	7000	350	5100
5/8	-10	690	10000	480	7000	280	4100	690	10000	480	7000	550	8000	480	7000	350	5100
3/4	-12	620	9000	450	6500	280	4100	620	9000	420	6100	420	6100	420	6100	280	4100
1	-16	620	9000	350	5100	215	3100	620	9000	350	5100	350	5100	350	5100	215	3100
1.1/4	-20	480	7000	215	3100			480	7000	215	3100	215	3100	215	3100	215	3100
1.1/2	-24	420	6100	100	1500			420	6100			100	1500	100	1500	215	3100
2	-32	350	5100	100	1500			350	5100			100	1500	100	1500	180	2600
2.1/2	-40	215	3100														

BSP	BSPP MALE ADJUSTABLE (O RING & RETAINING RING)	BSPP MALE (BONDED SEAL)	BSPP MALE (ENCAPSULATED SEAL)
-----	--	-------------------------	-------------------------------



THREAD SIZE	DASH SIZE	MAX. WORKING PRESSURE					
		bar	psi	bar	psi	bar	psi
1/8	-02	380	5500	420	6100	620	9000
1/4	-04	350	5100	420	6100	620	9000
3/8	-06	350	5100	420	6100	480	7000
1/2	-08	310	4500	350	5100	480	7000
5/8	-10			350	5100	480	7000
3/4	-12	280	4100	280	4100	480	7000
1	-16	215	3100	280	4100	370	5300
1.1/4	-20	170	2500	280	4100	280	4100
1.1/2	-24			215	3100	280	4100
2	-32			150	2100	230	3300

# GUIDE TO THREAD AND CONNECTOR WORKING PRESSURES

NPT	NPT MALE	NPT MALE LIVE SWIVEL	NPT FEMALE FIXED	NPSM FEMALE SWIVEL (CRIMP NUT)	NPSM FEMALE SWIVEL (WIRE NUT)
-----	----------	----------------------	------------------	--------------------------------	-------------------------------

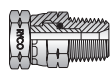

JSEAL™	JSEAL™ FEMALE CONCAVE SEAT
--------	----------------------------



THREAD SIZE	DASH SIZE	MAX. WORKING PRESSURE									
		bar	psi	bar	psi	bar	psi	bar	psi	bar	psi
1/8	-02	760	11000	420	6100	760	11000	690	10000		
1/4	-04	760	11000	420	6100	760	11000	690	10000		
3/8	-06	690	10000	420	6100	690	10000	690	10000		
1/2	-08	690	10000	350	5100	690	10000	550	8000		
5/8	-10										
3/4	-12	690	10000	280	4100	690	10000	450	6500	480	7000
1	-16	500	7200	280	4100	500	7200	350	5100	420	6100
1.1/4	-20	350	5100			350	5100	280	4100	420	6100
1.1/2	-24	350	5100			350	5100	280	4100	280	4100
2	-32	350	5100			350	5100	215	3100	215	3100
2.1/2	-40	215	3100							215	3100

THREAD SIZE	DASH SIZE	MAX. WORKING PRESSURE	
		bar	psi
7/16	-07	700	10100
1/2	-08	700	10100
9/16	-09	700	10100
3/4	-12	630	9100
7/8	-14	630	9100
1.1/16	-17	560	8100
1.3/16	-19	490	7100
1.5/16	-21	420	6100
1.5/8	-26	420	6100
1.7/8	-30	350	5100
2.1/2	-40	280	4100

JIS	METRIC FEMALE SWIVEL 60° CONCAVE SEAT
-----	---------------------------------------



THREAD SIZE	DASH SIZE	MAX. WORKING PRESSURE	
mm		bar	psi
M14 x 1,5	-14	420	6100
M16 x 1,5	-16	420	6100
M18 x 1,5	-18	420	6100
M22 x 1,5	-22	380	5500
M24 x 1,5	-24	350	5100
M27 x 2,0	-27	280	4100
M30 x 1,5	-30	280	4100
M33 x 1,5	-33	215	3100
M33 x 2,0	-33	215	3100
M36 x 1,5	-36	170	2500
M42 x 1,5	-42	170	2500
M50 x 2,0	-50	100	1500
M60 x 2,0	-60	70	1000

JIC	JIC MALE	JIC FEMALE SWIVEL (CRIMP NUT)	JIC FEMALE SWIVEL (WIRE NUT)	JIC FEMALE SWIVEL HIGH PRESSURE ("V" SERIES)
-----	----------	-------------------------------	------------------------------	--



TUBE SIZE	THREAD SIZE	DASH SIZE	MAX. WORKING PRESSURE							
			bar	psi	bar	psi	bar	psi	bar	psi
3/16	3/8	-06	690	10000	690	10000				
1/4	7/16	-07	690	10000	690	10000				
5/16	1/2	-08	620	9000	620	9000				
3/8	9/16	-09	550	8000	550	8000				
1/2	3/4	-12	690	10000	690	10000				
5/8	7/8	-14	550	8000	550	8000	590	8500		
3/4	1.1/16	-17	480	7000	480	7000	550	8000		
7/8	1.3/16	-19	420	6100	380	5500	420	6100		
1	1.5/16	-21	420	6100	320	4600	240	3500	350	5100
1.1/4	1.5/8	-26	350	5100	215	3100	240	3500	350	5100
1.1/2	1.7/8	-30	215	3100			215	3100	350	5100
2	2.1/2	-40	150	2100			110	1600		
2.1/2	3	-48								

INTRODUCTION

HOSE

COUPLINGS

ADAPTORS

TECHNICAL

# TECHNICAL

## GUIDE TO THREAD AND CONNECTOR WORKING PRESSURES

<b>JIS</b>	<b>BSPP MALE</b>	<b>BSPP FEMALE</b>
	<b>60° CONVEX SEAT</b>	<b>SWIVEL 60° CONCAVE SEAT</b>



THREAD SIZE	DASH SIZE	MAX. WORKING PRESSURE			
		bar	psi	bar	psi
inch					
1/4	-04	480	7000	480	7000
3/8	-06	450	6500	450	6500
1/2	-08	350	5100	350	5100
5/8	-10				
3/4	-12				
1	-16				

### METRIC DKOL (LIGHT SERIES) MALE & FEMALE O RING

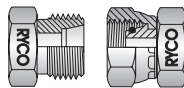

TUBE SIZE	THREAD SIZE	DASH SIZE	MAX. WORKING PRESSURE	
mm	mm		bar	psi
6	M12 x 1,5	-12	430	6300
8	M14 x 1,5	-14	430	6300
10	M16 x 1,5	-16	430	6300
12	M18 x 1,5	-18	350	5100
15	M22 x 1,5	-22	350	5100
18	M26 x 1,5	-26	350	5100
22	M30 x 2,0	-30	280	4100
28	M36 x 2,0	-36	215	3100
35	M45 x 2,0	-45	180	2600
42	M52 x 2,0	-52	180	2600

### METRIC DKOS (HEAVY SERIES) MALE & FEMALE O RING

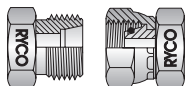

TUBE SIZE	THREAD SIZE	DASH SIZE	MAX. WORKING PRESSURE	
mm	mm		bar	psi
6	M14 x 1,5	-12	690	10000
8	M16 x 1,5	-14	690	10000
10	M18 x 1,5	-16	690	10000
12	M20 x 1,5	-20	620	9000
14	M22 x 1,5	-22	620	9000
16	M24 x 2,0	-24	420	6100
20	M30 x 2,0	-30	420	6100
25	M36 x 2,0	-36	420	6100
30	M42 x 2,0	-45	420	6100
38	M52 x 2,0	-52	420	6100

### METRIC BONDED SEAL



THREAD SIZE	DASH SIZE	MAX. WORKING PRESSURE	
mm		bar	psi
M10	-10	350	5100
M12	-12	350	5100
M14	-14	350	5100
M16	-16	350	5100
M18	-18	350	5100
M20	-20	280	4100
M22	-22	280	4100
M24	-24	250	3625
M26	-26	250	3625
M27	-27	280	4100
M30	-30	215	3100
M33	-33	215	3100
M36	-36	215	3100
M42	-42	215	3100
M48	-48	215	3100

### ORFS O RING FACE SEAL

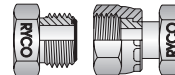

TUBE SIZE	THREAD SIZE	DASH SIZE	MAX. WORKING PRESSURE	
inch	inch		bar	psi
1/4	9/16	-09	690	10000
3/8	11/16	-11	690	10000
1/2	13/16	-13	630	9150
5/8	1	-16	630	9150
3/4	1.3/16	-19	480	7000
1	1.7/16*	-23	420	6100
1.1/4	1.11/16*	-27	280	4100
1.1/2	2*	-32	280	4100

\* Wire Nut used

# GUIDE TO THREAD AND CONNECTOR WORKING PRESSURES

<b>SAE</b>	<b>SAE 45° FLARE</b>	<b>SAE INVERTED FLARE</b>
------------	----------------------	---------------------------



TUBE SIZE	THREAD SIZE	DASH SIZE	MAX. WORKING PRESSURE			
			bar	psi	bar	psi
1/4	7/16	-07	690	10000	215	3100
5/16	1/2	-08	690	10000	215	3100
3/8	5/8	-10	590	8500	180	2600
7/16	11/16	-11			180	2600
1/2	3/4	-12	550	8000		
5/8	7/8	-14	520	7500		
3/4	1.1/16	-17	420	6100		
1	1.5/16	-21				
1.1/4	1.5/8	-26				
1.1/2	1.7/8	-30				
2	2.1/2	-40				

<b>SAE FLANGE</b>	<b>CODE 61 SAE FLANGE</b>	<b>CODE 62 SAE FLANGE</b>	<b>RYCO CODE 62C SPECIAL FLANGE</b>
-------------------	---------------------------	---------------------------	-------------------------------------

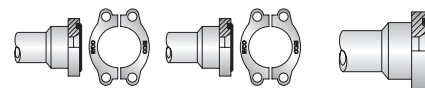

NOM. FLANGE SIZE	DASH SIZE	MAX. WORKING PRESSURE					
		bar	psi	bar	psi	bar	psi
1/2	-08	350	5100	420	6100	420	6100
5/8	-10	350	5100	420	6100	420	6100
3/4	-12	350	5100	420	6100	420	6100
1	-16	350	5100	420	6100	420	6100
1.1/4	-20	280	4100	420	6100	420	6100
1.1/2	-24	215	3100	420	6100	420	6100
2	-32	215	3100	420	6100	420	6100
2.1/2	-40	215	3100				
3	-48	140	2050				

INTRODUCTION

HOSE

COUPLINGS

ADAPTORS

TECHNICAL

<b>RYCOLOK SUPERLOK SUPER-D</b>	<b>RYCOLOK MALE &amp; FEMALE</b>	<b>SUPERLOK MALE &amp; FEMALE</b>	<b>RYCO SUPER-D MALE &amp; FEMALE</b>
---------------------------------	----------------------------------	-----------------------------------	---------------------------------------

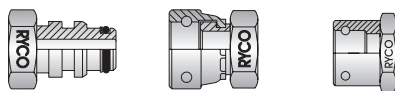

NOMINAL SIZE	MAX. WORKING PRESSURE								
	DN	inch	Dash	bar	psi	bar	psi	bar	psi
6	1/4	-06	420	6100					
10	3/8	-10	420	6100					
12	1/2	-12	415	6020					
16	5/8	-16							
19	3/4	-20	350	5100	420	6100	420	6100	
25	1	-25	280	4100	380	5500	420	6100	
31	1.1/4	-32	215	3100	350	5100	420	6100	
38	1.1/2	-40	215	3100	350	5100	420	6100	
51	2	-50	170	2500	350	5100	420	6100	
63	2.1/2	-63			350	5100			

**WARNING:** Staples must only be used ONCE, they MUST NOT BE RE-USED.  
This applies to all RYCOLOK, SUPERLOK and RYCO SUPER-D Staples. Failure to observe this warning may result in serious personal injury, or property damage.

# TECHNICAL

## GUIDE TO THREAD AND CONNECTOR WORKING PRESSURES

### RYCO WEO



TUBE SIZE	DASH SIZE	MAX. WORKING PRESSURE	
inch		bar	psi
1/4	-04	350	5100
3/8	-06	350	5100
1/2	-08	350	5100
5/8	-10	350	5100
3/4	-12	350	5100
1	-16	250	3625

### TUBE BITE

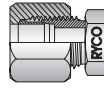

TUBE SIZE	DASH SIZE	MAX. WORKING PRESSURE	
inch		bar	psi
1/4	-04	260	3750
5/16	-05	260	3750
3/8	-06	260	3750
1/2	-08	220	3200
5/8	-10	220	3200
3/4	-12	220	3200
1	-16	170	2500
1.1/4	-20	140	2000
1.1/2	-24		
2	-32		

**NOTE:** Also consider the Maximum Working Pressure of the tubing to be used with TUBE BITE connections.

### UN O RING (O RING BOSS)

#### UN O RING (O RING BOSS)

#### UN O RING (O RING BOSS) ADJUSTABLE

#### UN O RING (O RING BOSS) LIVE SWIVEL

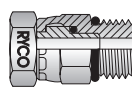

TUBE SIZE	THREAD SIZE	DASH SIZE	MAX. WORKING PRESSURE					
			bar	psi	bar	psi	bar	psi
1/4	7/16	-07	480	7000	420	6100		
5/16	1/2	-08	480	7000	420	6100		
3/8	9/16	-09	480	7000	350	5100	350	5100
1/2	3/4	-12	480	7000	350	5100	350	5100
5/8	7/8	-14	480	7000	280	4100	280	4100
3/4	1.1/16	-17	480	7000	280	4100	280	4100
7/8	1.3/16	-19	480	7000	280	4100		
1	1.5/16	-21	350	5100	280	4100		
1.1/4	1.5/8	-26	215	3100	170	2500		
1.1/2	1.7/8	-30	215	3100				
2	2.1/2	-38						

## IMPORTANT NOTE REGARDING THREAD DASH SIZE/TUBE DASH SIZE

### TUBE DASH SIZE - THREAD DASH SIZE

The RYCO Dash Size Part Numbering system for Connection Types associated with Inch sized tubing, follows the **THREAD** size rather than the **TUBE** size.

For example, for JIC 37° Flare; 9/16" **THREAD** is used with 3/8" OD **TUBE**.

The RYCO DASH SIZE for a JIC Hose Tail, 3/8" Hose to 3/8" Tube Size is therefore **-0609** (not -0606).

The Connection Types this applies to are as follows:

**JSEAL**

**JIC 37°**

**UNO (O Ring Boss)**

**ORFS (O Ring Face Seal)**

**SAE 45°**

**SAE Inverted Flare**

BSP, NPT, JIS, Metric DIN, and SAE Flanges are not affected.

The tables below show the relationship between **TUBE Dash Size** and **THREAD Dash Size**.

#### JSEAL™/JIC 37° AND UNO (O RING BOSS)

TUBE OD HOSE ID	DASH SIZE		THREAD SIZE
	TUBE/HOSE	THREAD	
1/8	-02	-05	5/16-24 UNF
3/16	-03	-06	3/8-24 UNF
1/4	-04	-07	7/16-20 UNF
5/16	-05	-08	1/2-20 UNF
3/8	-06	-09	9/16-18 UNF
1/2	-08	-12	3/4-16 UNF
5/8	-10	-14	7/8-14 UNF
3/4	-12	-17	1.1/16-12 UN
7/8	-14	-19	1.3/16-12 UN
1	-16	-21	1.5/16-12 UN
1.1/4	-20	-26	1.5/8-12 UN
1.1/2	-24	-30	1.7/8-12 UN
2	-32	-40	2.1/2-12 UN
2.1/2	-40	-48	3-12 UN

#### SAE 45°

TUBE OD HOSE ID	DASH SIZE		THREAD SIZE
	TUBE/HOSE	THREAD	
1/8	-02	-05	5/16-24
3/16	-03	-06	3/8-24
1/4	-04	-07	7/16-20
5/16	-05	-08	1/2-20
3/8	-06	-10	5/8-18
1/2	-08	-12	3/4-16
5/8	-10	-14	7/8-14
3/4	-12	-17	1.1/16-14

#### SAE INVERTED FLARE

TUBE OD HOSE ID	DASH SIZE		THREAD SIZE
	TUBE/HOSE	THREAD	
1/4	-04	-07	7/16-24
5/16	-05	-08	1/2-20
3/8	-06	-10	5/8-18
7/16	-07	-11	11/16-18

#### ORFS (O RING FACE SEAL)

TUBE OD HOSE ID	DASH SIZE		THREAD SIZE
	TUBE/HOSE	THREAD	
1/4	-04	-09	9/16-18 UNF
3/8	-06	-11	11/16-16 UN
1/2	-08	-13	13/16-16 UN
5/8	-10	-16	1-14 UNS
3/4	-12	-19	1.3/16-12 UN
1	-16	-23	1.7/16-12 UN
1.1/4	-20	-27	1.11/16-12 UN
1.1/2	-24	-32	2-12 UN

#### RYCO RYCOLOK & SUPERLOK

NOMINAL SIZE DN	INCH	DASH SIZE
10	3/8	-10
12	1/2	-12
16	5/8	-16
19	3/4	-20
25	1	-25
31	1.1/4	-32
38	1.1/2	-40
51	2	-50
63	2.1/2	-63
76	3	-75

For RYCO, RYCOLOK and SUPERLOK, the Dash Size is the Nominal Size in millimetres.

INTRODUCTION

HOSE

COUPLINGS

ADAPTORS

TECHNICAL



# TECHNICAL

## THREAD AND CONNECTOR IDENTIFICATION

### HOW TO USE THIS SECTION

This section is intended as an aid to identifying the most popular threads on hydraulic hose couplings and adaptors, and hydraulic equipment.

BSP, Metric, American and Japanese thread sizes can be very similar. It is important to measure and match every criteria of thread diameter, thread pitch, seating or sealing type (including angle of seats if present) to accurately determine thread type.

### PROCEDURE

#### STEP 1. INVESTIGATION

Check for any markings on fitting or equipment which may be a clue to thread type. Country of origin may provide a clue.

<b>Europe</b>	Check DIN/BSP
<b>UK/Australia</b>	Check BSP
<b>America</b>	Check NPT/JIC/UNO/ORFS
<b>Japan</b>	Check JIS

All RYCO parts have a unique part number stamped on to aid identification.

#### STEP 2. VISUAL INSPECTION

Depending on whether the male or female thread or both are available, different features will aid identification.

- Are threads parallel or tapered?
- Is there an O Ring or a washer seal?
- If cone seats are present, are they concave or convex?
- Type and position on fittings.

#### STEP 3. MEASURE THREADS

With a caliper, measure the thread diameter.

- OD of male threads
- ID of female threads

Using a thread gauge, determine the number of threads per inch.

If thread gauge is not available, measure pitch from crest to crest of adjacent threads, or count the number of threads in 1/4" and multiply by four for threads per inch. Chart at bottom of page may assist.

#### STEP 4. SEAT ANGLE MEASUREMENT

Using a seat gauge, determine the angle of the seat. Some fittings have dual seats (eg. JIC 37° & SAE 45°), and some have a radiused cone.

#### STEP 5. CONCLUSION

Match the measurements taken against those in the tables herein that appear to be similar to the coupling under consideration.

A final check can be achieved by mating with an actual coupling of the same thread.



### THREAD ID MATE

#### THREAD IDENTIFICATION AT YOUR FINGERTIPS

In 2013, RYCO introduced the Thread ID Mate smartphone app to aid thread identification.

The RYCO Thread ID Mate application enables you to identify hydraulic threads and connectors everywhere you go. The intuitive and simple identification process will help you find detailed information about threads specifications, sizes and more...

The Thread ID Mate app is available for your Android smartphone, iPhone/iPod Touch. Thread identification you can keep in your pocket!

Find out more at [www.RYCO.com.au](http://www.RYCO.com.au)

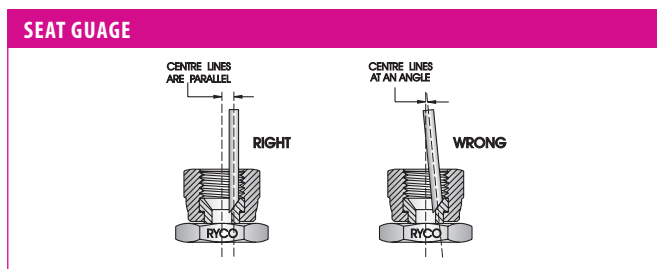
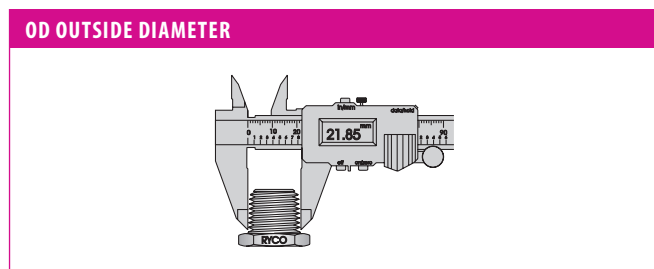
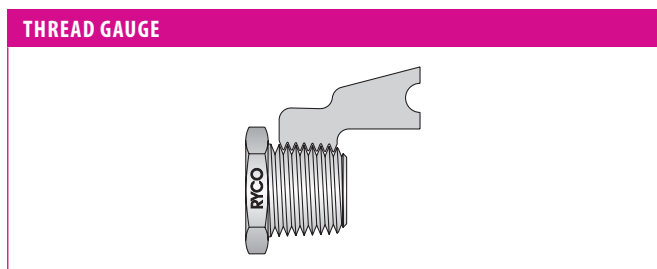
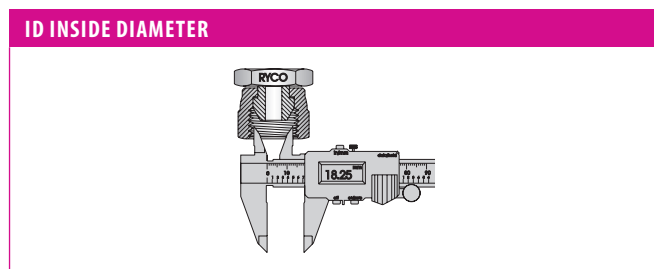

TPI (Threads Per Inch)	28	27	24	20	19	18	16	14	12	11.5	11	8	16.9	12.7
Thread PITCH (mm)	0,91	0,94	1,06	1,27	1,34	1,4	1,59	1,81	2,12	2,21	2,31	3,18	1,5	2,0

## BSPT & BSPP THREADS

**BSP IS BRITISH STANDARD PIPE**  
**BSPT IS BRITISH STANDARD PIPE TAPER**

**ALSO KNOWN AS WHITWORTH 55° THREAD FORM**  
**THREAD FORM PER AS 1722.1, BS 21, ISO 7-1,**  
**DIN 3852-2 FORM C (MALE), DIN 3852-2 FORM Z (FEMALE)**

**BSPP IS BRITISH STANDARD PIPE PARALLEL**  
**BSPO IS BRITISH STANDARD PIPE PARALLEL O-RING**

**THREAD FORM PER AS 1722.2, ISO 228 (THREAD TYPE), ISO 1179**  
**THREAD FORM PER AS 1722.2, ISO 228 (THREAD TYPE),**  
**ISO 8434-6, BS 5200**

INTRODUCTION

HOSE

COUPLINGS

ADAPTORS

TECHNICAL

BSPT male threads seal against threads of fixed BSPT female. Contact is made on the flanks of the threads. Use of a thread sealant is recommended for BSPT male to BSPT female connections.

Measure the BSPT male thread OD and female thread ID at the first full thread near the end of the fitting.

BSPT male and BSPP male with conical 30° seat (60° included angle) seal against matching conical 30° seat of BSPP female swivel and BSPP female swivel with O Ring.

BSPO is BSPP O-Ring Female Swivel, and connects to BSPT male and BSPP male with conical 30° seat (60° included angle). Sealing is achieved against the matching conical 30° seat of BSPO female swivel, with the O Ring providing additional sealing capability.

BSPP O-Ring male connector has straight threads and O-Ring with metal Retaining Ring. It seals against flat external surface of BSPP female port. BSPP male, with chamfer to locate Bonded Seal also seals against flat external surface of BSPP female port.

Surface irregularities require a Spot Face to ensure effective sealing. Elbows and tees have Lock Nut to allow orientation of fitting to required direction.

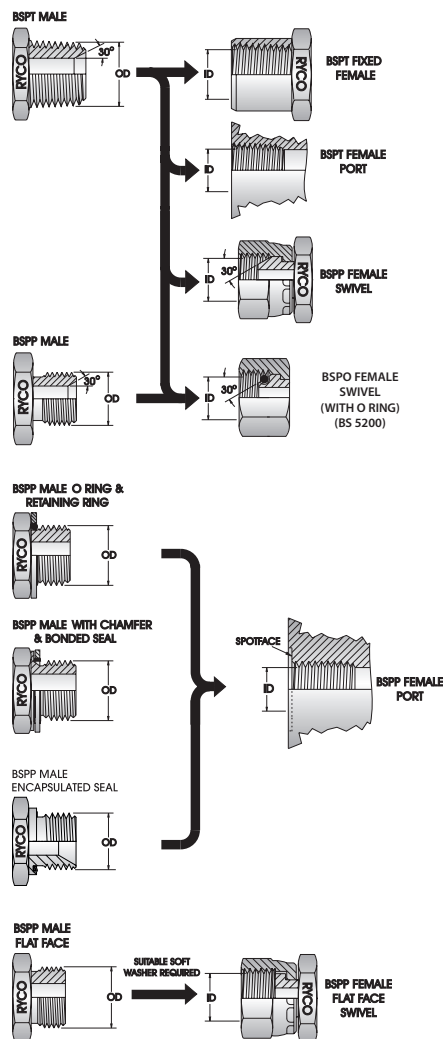

BSPP male and BSPP female flat face swivel require a suitable soft washer between faces to seal.

For low working pressure.

## BSPT & BSPP THREAD DIMENSIONS

BSPT & BSPP SIZE & PITCH	DASH SIZE	BSPT MALE THREAD OD		BSPP MALE THREAD OD		BSPT FEMALE THREAD ID		BSPP FEMALE THREAD ID	
		mm	inch	mm	inch	mm	inch	mm	inch
1/8 - 28	-02	9,5	0.37	9,6	0.38	8,4	0.33	8,6	0.34
1/4 - 19	-04	12,8	0.50	13,0	0.51	11,2	0.44	11,9	0.47
3/8 - 19	-06	16,3	0.64	16,5	0.65	14,7	0.59	15,2	0.60
1/2 - 14	-08	20,4	0.80	20,8	0.82	18,3	0.72	19,1	0.75
5/8 - 14	-10	22,5	0.89	22,8	0.90	20,6	0.81	20,8	0.82
3/4 - 14	-12	25,9	1.02	26,3	1.04	23,9	0.94	24,6	0.97
1 - 11	-16	32,6	1.28	33,1	1.30	29,7	1.17	30,7	1.21
1.1/4 - 11	-20	41,1	1.62	41,8	1.64	38,6	1.52	39,4	1.55
1.1/2 - 11	-24	47,0	1.85	47,7	1.88	44,5	1.75	45,5	1.79
2 - 11	-32	58,6	2.31	59,5	2.34	56,4	2.22	57,4	2.26
2.1/2 - 11	-40	74,1	2.92	75,1	2.95	71,9	2.83	72,6	2.86
3 - 11	-48	86,6	3.41	87,9	3.46	84,6	3.33	85,4	3.36

Thread size refers to the nominal bore of the pipe. Subtract approx. 1/4" (6 mm) from thread diameter measurement for nominal pipe size. Pitch is Threads Per Inch (TPI). "Gas", "R" & "G" also refer to BSP. "Male Iron (Pipe)" may be BSP or NPT.

# TECHNICAL

## THREAD AND CONNECTOR IDENTIFICATION

### NPT & NPS THREADS

NPT	IS	NATIONAL PIPE TAPER (AMERICAN)	THREAD FORM PER ANSI/ASME B1.20.1
NPS	IS	NATIONAL PIPE STRAIGHT (PARALLEL)	THREAD FORM PER ANSI/ASME B1.20.1
NPTF	IS	NATIONAL PIPE TAPER FOR FUEL	THREAD FORM PER SAE J476a, ANSI/ASME B1.20.3
NPSM	IS	NATIONAL PIPE STRAIGHT MECHANICAL	THREAD FORM PER ANSI/ASME B1.20.1, SAE J514

National Pipe threads are similar in function to BSP threads, but are not generally interchangeable. NPTF threads (also known as Dryseal) are an improvement to NPT. Controlled truncation of threads mean the metal-to-metal thread seal is at root and crest of threads, in addition to flanks of threads. Use of thread sealant is recommended for NPT male and NPT.

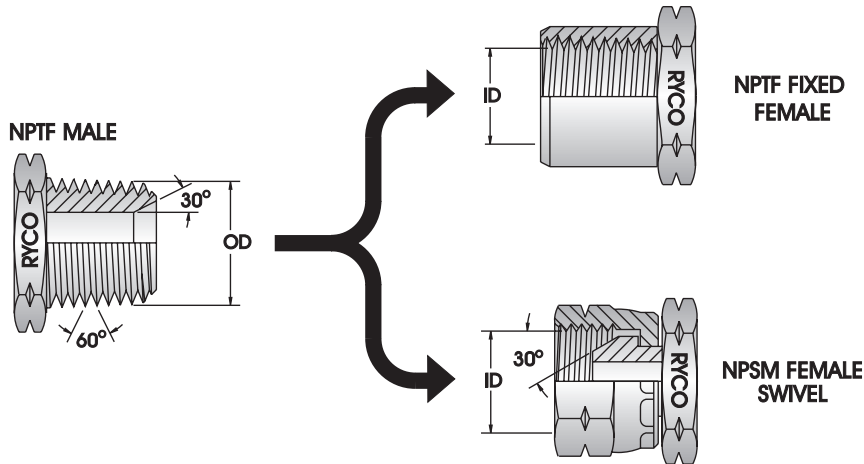

Measure NPT male thread OD and NPT female thread ID at first full thread near end of fitting.

### NPT THREAD DIMENSIONS

NPT THREAD SIZE & PITCH	DASH SIZE	MALE THREAD MINOR OD		FEMALE THREAD ID	
inch - TPI		mm	inch	mm	inch
1/8 - 27	-02	9,9	0.39	8,4	0.33
1/4 - 18	-04	13,2	0.52	11,2	0.44
3/8 - 18	-06	16,6	0.65	14,7	0.58
1/2 - 14	-08	20,6	0.81	17,8	0.70
3/4 - 14	-12	26,0	1.02	23,4	0.92
1 - 11.1/2	-16	32,5	1.28	29,5	1.16
1.1/4 - 11.1/2	-20	41,2	1.62	38,1	1.50
1.1/2 - 11.1/2	-24	47,3	1.86	43,9	1.73
2 - 11.1/2	-32	59,3	2.33	56,4	2.22
2.1/2 - 8	-40	71,5	2.82	69,1	2.72
3 - 8	-48	87,3	3.44	84,8	3.34

### NPSM THREAD DIMENSIONS

NPSM THREAD SIZE	DASH SIZE	FEMALE THREAD ID	
inch - TPI		mm	inch
1/8 - 27	-02	8,6	0.34
1/4 - 18	-04	11,9	0.47
3/8 - 18	-06	15,0	0.59
1/2 - 14	-08	19,1	0.75
3/4 - 14	-12	24,6	0.97
1 - 11.1/2	-16	30,5	1.20
1.1/4 - 11.1/2	-20	39,4	1.55
1.1/2 - 11.1/2	-24	45,5	1.79
2 - 11.1/2	-32	57,4	2.26
2.1/2 - 8	-40	68,8	2.71
3 - 8	-48	84,6	3.33

**NOTE:** Thread size refers to the nominal bore of the pipe.  
 Subtract approximately 1/4" (6 mm) from thread measurement for nominal pipe size.  
 Pitch is Threads Per Inch (TPI).

## JSEAL™/ JIC 37° FLARE & UNO (O RING BOSS) THREADS

<b>JSEAL™ IS</b>	<b>RYCO JSEAL™</b>	<b>PROPRIETARY CONNECTION</b>
<b>JIC IS</b>	<b>JOINT INDUSTRIES COUNCIL</b>	<b>SAE J514, ISO 8434-2</b>
<b>UN IS</b>	<b>UNIFIED NATIONAL</b>	<b>SAE J1926, ISO 11926-2</b>

**JIC & UNO (O RING BOSS) THREAD FORMS ARE THE SAME (ASME B1.1). METHOD OF SEALING DIFFERS.**

INTRODUCTION

HOSE

COUPLINGS

ADAPTORS

TECHNICAL

JSEAL™ is a RYCO proprietary connection that is fully interchangeable and backwards compatible with standard JIC connections.

With a repositioned strike zone away from the male tip, JSEAL™ design drives unrivalled performance, eliminating sweating, cracking, and stretching, while simplifying installation.

The design of JSEAL™ features a convex female seat that is engineered to be used with any JIC Male connection.

JIC male has 37° flare which seals against 37° seat in female.

JIC male can also seal against 37° flared tubing with JIC nut and sleeve.

JIC male can also be used with RYCO S134 J-Lok Female Nut and Flareless Olive on Imperial OD tubing.

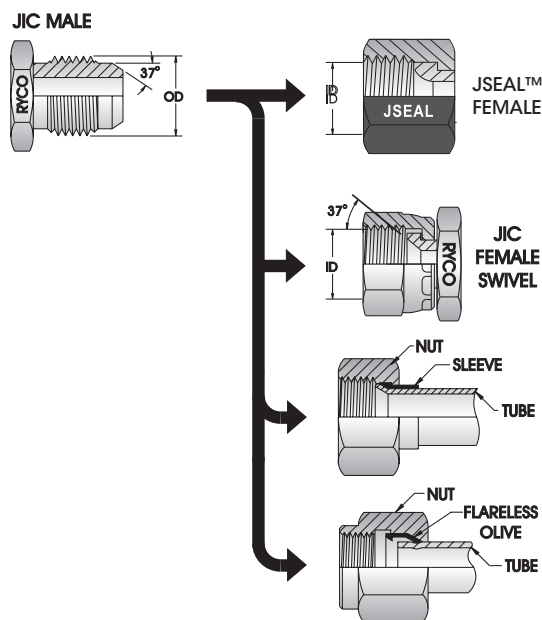

UNO (O Ring Boss) seals with O Ring compressed between hex boss of UN male and 12°/15° tapered bore of UN (O Ring Boss) female port. For elbows and tees, Back up Washer and Lock Nut allow orientation of fitting to required direction.

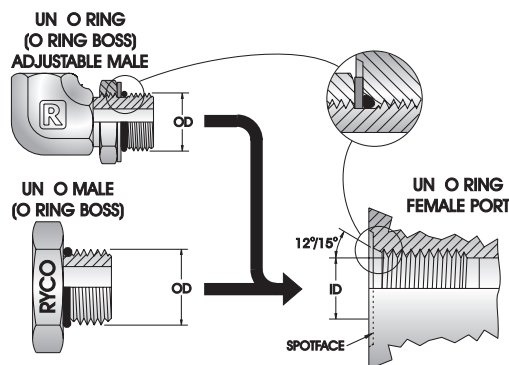

## JIC & UNO THREAD DIMENSIONS

MALE THREAD OD & PITCH	DASH SIZE	MALE THREAD OD		FEMALE THREAD ID		TUBE SIZE
inch - TPI		mm	inch	mm	inch	inch
5/16 - 24 UNF	-05	7,9	0.31	6,9	0.27	1/8
3/8 - 24 UNF	-06	9,5	0.38	8,5	0.33	3/16
7/16 - 20 UNF	-07	11,1	0.44	9,9	0.39	1/4
1/2 - 20 UNF	-08	12,7	0.50	11,4	0.45	5/16
9/16 - 18 UNF	-09	14,3	0.56	13,0	0.51	3/8
3/4 - 16 UNF	-12	19,1	0.75	17,5	0.69	1/2
7/8 - 14 UNF	-14	22,2	0.88	20,3	0.80	5/8
1.1/16 - 12 UN	-17	27,0	1.06	24,9	0.98	3/4
1.3/16 - 12 UN	-19	30,2	1.19	28,2	1.11	7/8
1.5/16 - 12 UN	-21	33,3	1.31	31,2	1.23	1
1.5/8 - 12 UN	-26	41,3	1.63	39,1	1.54	1.1/4
1.7/8 - 12 UN	-30	47,6	1.88	45,5	1.79	1.1/2
2.1/2 - 12 UN	-40	63,5	2.50	61,5	2.42	2

Thread size is actual measurement of male thread and pitch is Threads Per Inch (TPI).

### JIS THREADS

JIS IS JAPANESE INDUSTRIAL STANDARDS

There are four popular coupling styles in Japan.

#### 1. JIS TAPERED PIPE THREAD.

Thread form per JIS B 0203 (identical to BSPT)

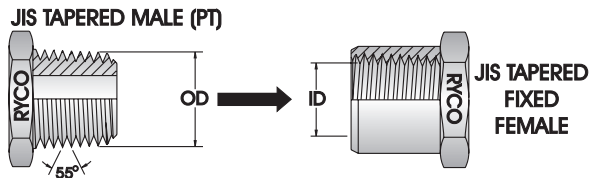

Refer to BSPT section for dimensions of threads.

- The Japanese tapered pipe thread connector is identical to and interchangeable with the BSPT (tapered) connector.
- The Japanese male thread does not have a 30° Flare, and will not mate with the BSPP female swivel with conical seat. The seal on the Japanese tapered pipe thread connector is made on the threads.
- Use of a thread sealant is recommended.

#### 2. JIS 30° FLARE (FEMALE INTERNAL CONE SEAT).

Thread form per JIS B 0202 (identical to BSPP)

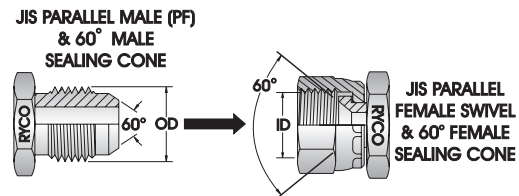

Refer to BSPP section for dimensions of threads.

- This connection uses a 60° concave (inverted) seat and British Standard Pipe Parallel threads.
- They are not interchangeable with BSPP conical seat couplings, because the cone seats are opposite.

#### 3. JIS 30° FLARE (FEMALE INTERNAL CONE SEAT).

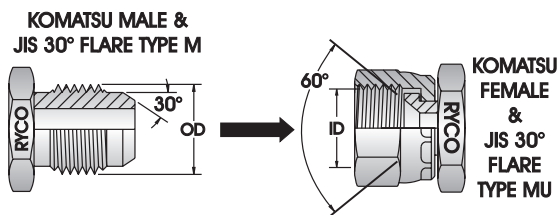

Thread form per JIS B 0207

- Threads commonly used on Komatsu equipment (30° cone) have metric thread form. See table opposite.

#### 4. KOMATSU® STYLE FLANGE FITTING JIS B 8363

- The Komatsu® style Flange fitting is nearly identical to, and fully interchangeable with, the SAE Code 61 flange fitting\*.
- The O Ring dimensions are different between all sizes.
- When replacing a Komatsu® style flange with an SAE style flange, an SAE style O Ring must always be used.
- \* 5/8" is not in the SAE Standards.

MALE THREAD OD & PITCH	DASH SIZE	FEMALE THREAD ID	KOMATSU®	JIS B 8363
mm		mm		
M14 x 1,5	-14	12,5	✓	✓
M16 x 1,5	-16	14,5	✓	
M18 x 1,5	-18	16,5	✓	✓
M22 x 1,5	-22	20,5	✓	✓
M24 x 1,5	-24	22,5	✓	
M27 x 2,0	-27	25,0		✓
M30 x 1,5	-30	28,5	✓	
M33 x 1,5	-33	31,5	✓	
M33 x 2,0	-33	31,0		✓
M36 x 1,5	-36	34,5	✓	
M42 x 1,5	-42	40,5	✓	
M50 x 2,0	-50	48,0		✓
M60 x 2,0	-60	58,0		✓

### BSPT & BSPP THREAD DIMENSIONS

BSPT & BSPP SIZE & PITCH	DASH SIZE	BSPT MALE THREAD OD	BSPP MALE THREAD OD	BSPT FEMALE THREAD ID	BSPP FEMALE THREAD ID
inch - TPI		mm	inch	mm	inch
1/8 - 28	-02	9,5	0.37	9,6	0.38
1/4 - 19	-04	12,8	0.50	13,0	0.51
3/8 - 19	-06	16,3	0.64	16,5	0.65
1/2 - 14	-08	20,4	0.80	20,8	0.82
5/8 - 14	-10	22,5	0.89	22,8	0.90
3/4 - 14	-12	25,9	1.02	26,3	1.04
1 - 11	-16	32,6	1.28	33,1	1.30
1.1/4 - 11	-20	41,1	1.62	41,8	1.64
1.1/2 - 11	-24	47,0	1.85	47,7	1.88
2 - 11	-32	58,6	2.31	59,5	2.34
2.1/2 - 11	-40	74,1	2.92	75,1	2.95
3 - 11	-48	86,6	3.41	87,9	3.46

Thread size refers to the nominal bore of the pipe. Subtract approx. 1/4" (6 mm) from thread diameter measurement for nominal pipe size.

Pitch is Threads Per Inch (TPI).

"Gas", "R" & "G" also refer to BSP. "Male Iron (Pipe)" may be BSP or NPT.

## THREAD AND CONNECTOR IDENTIFICATION

### METRIC FRENCH GAZ ALSO KNOWN AS METRIC FRENCH GAZ 24°

These seal on a 24° cone seat located internally on the male connector using straight fine metric threads. Metric French GAZ series uses fractional number metric OD tubing, as shown in the table. Metric French Millimetric series uses whole number metric OD tubing. The two series are not interconnectable.

The male will mate with a straight thread female swivel with spherical nose seat.

The same male also mates with flareless tube, Tube Nut and Compression Olive (Cutting Ring). Tightening of the female nut compresses the olive causing it cut into the tube, thereby forming a seal between the tube, olive and 24° male cone.

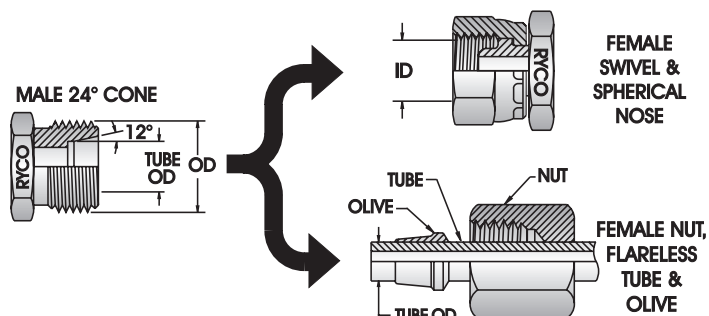

MALE THREAD OD & PITCH	DASH SIZE	MALE THREAD OD	FEMALE THREAD ID	TUBE SIZE
inch - TPI		mm	inch	mm
M20 x 1,5	-20	20,0	0.78	13,25
M24 x 1,5	-24	24,0	0.94	16,75
M30 x 1,5	-30	30,0	1.18	21,25
M36 x 1,5	-36	36,0	1.41	26,75
M45 x 1,5	-45	45,0	1.77	33,50
M52 x 1,5	-52	52,0	2.04	42,25

### METRIC FRENCH MILLIMETRIC ALSO KNOWN AS METRIC MILLIMETRIC

These seal on a 24° cone seat located internally on the male connector using straight fine metric threads.

Metric French GAZ series uses fractional number metric OD tubing, as shown in the table.

Metric French Millimetric series uses whole number metric OD tubing. The two series are not interconnectable.

The male will mate with a straight thread female swivel with spherical nose seat.

The same male also mates with flareless tube, Tube Nut and Compression Olive (Cutting Ring). Tightening of the female nut compresses the olive causing it cut into the tube, thereby forming a seal between the tube, olive and 24° male cone.

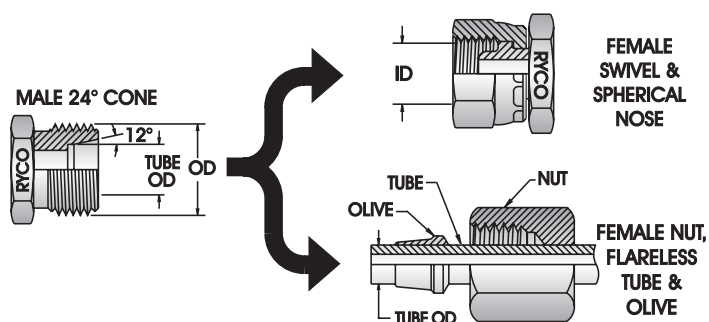

MALE THREAD OD & PITCH	DASH SIZE	MALE THREAD OD	FEMALE THREAD ID	TUBE SIZE
inch - TPI		mm	inch	mm
M27 x 1,5	-27	27,0	1.06	20
M30 x 1,5	-30	30,0	1.18	22
M33 x 1,5	-33	33,0	1.30	25
M36 x 1,5	-36	36,0	1.41	28
M39 x 1,5	-39	39,0	1.54	30
M45 x 1,5	-45	45,0	1.77	35

INTRODUCTION

HOSE

COUPLINGS

ADAPTORS

TECHNICAL



# TECHNICAL

## THREAD AND CONNECTOR IDENTIFICATION

### METRIC DIN THREADS

**DIN IS DEUTSCHE INDUSTRIE NORMEN (GERMAN INDUSTRIAL STANDARD) 24° CONE SEAT PER DIN 3861, ISO 8434-1/DIN 2353 O RING SEAL PER DIN 3865, BONDED SEAL AND PORT PER DIN 3852-1**

<b>DKL</b>	<b>IS</b>	<b>DICHT KEGEL LEICHT</b>	<b>(METRIC LIGHT SERIES 24° CONE)</b>
<b>DKS</b>	<b>IS</b>	<b>DICHT KEGEL SCHWER</b>	<b>(METRIC HEAVY SERIES 24° CONE)</b>
<b>DKOL</b>	<b>IS</b>	<b>DICHT KEGEL O RING LEICHT</b>	<b>(METRIC LIGHT O RING SERIES 24° CONE)</b>
<b>DKOS</b>	<b>IS</b>	<b>DICHT KEGEL O RING SCHWER</b>	<b>(METRIC HEAVY O RING SERIES 24° CONE)</b>
<b>DKM</b>	<b>IS</b>	<b>DICHT KEGEL METRIC</b>	<b>(METRIC 60° CONE)</b>

This DIN connection comes in a Light Series (DKL/DKOL) and a Heavy Series (DKS/DKOS). Some thread sizes in each series are the same, but the Tube OD of the Heavy Series is smaller and has a thicker tube wall. Because the tube and sealing cone are different sizes, Light and Heavy Series are NOT interchangeable.

The DIN male 24° internal cone seat will seal with flareless female swivel fittings. These female fittings use either a spherical nose (DKL/DKS) or an O Ring seal (DKOL/DKOS) located on their outward facing 24° cone. Female DKL sizes up to and including M26 have a universal 24°/60° cone and can be used in place of female DKM fittings with 60° cone.

The same male also mates with the DIN system Metric Tube, Tube Nut and Compression Olive (Cutting Ring). Tightening of the female nut compresses the olive causing it to cut into the tube, thereby forming a seal between the tube, olive and 24° male cone.

The same male used with a metal Bonded Seal will mate with a DIN 3852-1 metric threaded port with spotface.

### DKM 60° CONE SEAT

The DIN male 60° internal cone seat will mate with DKL/DKM female universal 24°/60° cone fittings up to and including size M26 and DKM female 60° cone fittings from size M30 up.

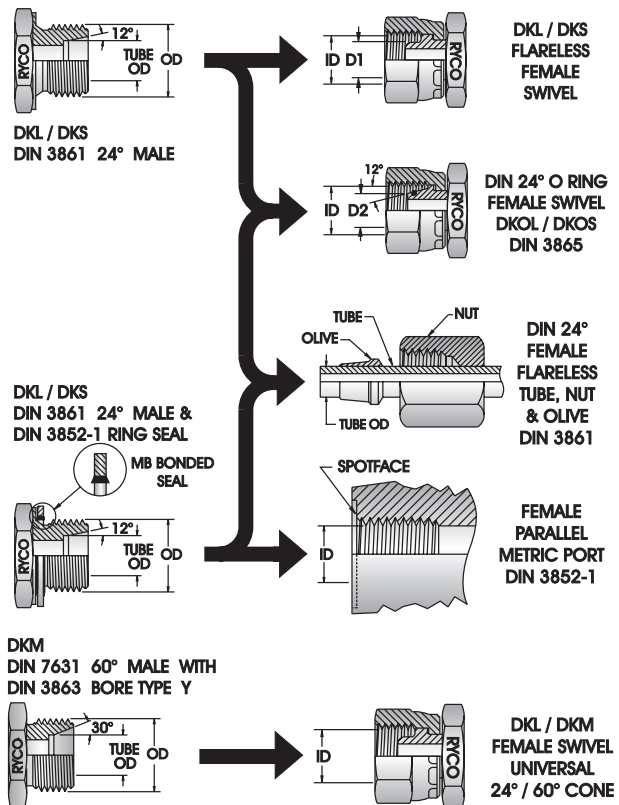

MALE THREAD OD & PITCH	FEMALE THREAD ID	LIGHT SERIES - DKL/DKOL				HEAVY SERIES - DKS/DKOS			
		DASH SIZE	TUBE OD	D1 DIA	D2 DIA	DASH SIZE	TUBE OD	D1 DIA	D2 DIA
mm	mm		mm	mm	mm		mm	mm	mm
M12 x 1,5	10,5	-1215*	6	7,5	6,3				
M14 x 1,5	12,5	-1415*	8	9,5	8,2	-1415	6	7,5	6,3
M16 x 1,5	14,5	-1615*	10	11,5	10,2	-1615	8	9,5	7,9
M18 x 1,5	16,5	-1815*	12	14,0	12,2	-1815	10	12,0	10,0
M20 x 1,5	18,5					-2015	12	14,0	12,0
M22 x 1,5	20,5	-2215*	15	17,0	15,2	-2215	14	16,0	14,2
M24 x 1,5	22,5					-2415	16	18,0	15,8
M26 x 1,5	24,5	-2615*	18	20,0	18,2				
M30 x 2,0	28,0	-3020	22	24,5	22,2	-3020	20	22,5	19,8
M36 x 2,0	34,0	-3620	28	30,5	28,2	-3620	25	27,5	24,5
M42 x 2,0	40,0					-4220	30	33,0	30,0
M45 x 2,0	43,0	-4520	35	38,0	35,4				
M52 x 2,0	50,0	-5220	42	45,0	42,4	-5220	38	41,0	36,8

\*These DKL Light Series Female Connections can be used in place of DKM Female.

**NOTE:** in above tables, pitch is included in DASH Size.

For HOSE COUPLINGS and most ADAPTORS, pitch is not included in the DASH Size.



## ORFS THREADS SAE J1453, ISO 8434-3

**ORFS IS O RING FACE SEAL**

ORFS system consists of ORFS Male with O Ring in Face, which seals against Flat Seated ORFS Female Swivel Nut fitting.

The Swivel Nut can be slipped back to help installation in tight situations.

The prominent position of the O Ring on the Male fitting makes it easy to inspect the condition of the O Ring.

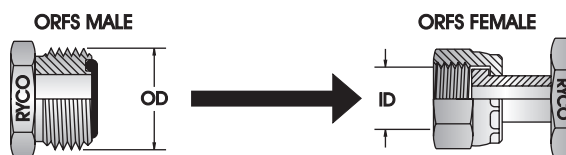

MALE THREAD OD & PITCH	DASH SIZE	MALE THREAD OD		FEMALE THREAD ID		TUBE SIZE
inch - TPI		mm	inch	mm	inch	inch
9/16 - 18 UNF	-09	14,3	0.56	12,9	0.51	1/4
11/16 - 16 UN	-11	17,3	0.68	16,0	0.63	3/8
13/16 - 16 UN	-13	20,6	0.81	19,1	0.75	1/2
1 - 14 UNS	-16	25,4	1.00	23,6	0.73	5/8
1.3/16 - 12 UN	-19	30,0	1.18	28,2	1.11	3/4
1.7/16 - 12 UN	-23	36,3	1.43	34,3	1.35	1
1.11/16 - 12 UN	-27	42,7	1.68	40,6	1.60	1.1/4
2 - 12 UN	-32	51,8	2.00	48,8	1.92	1.1/2

### SAE THREADS

SAE IS SOCIETY OF AUTOMOTIVE ENGINEERS

These fittings are commonly used in refrigeration, automotive and low pressure applications.

#### SAE 45° FLARE SAE J512

SAE male has 45° flare which seals against 45° seat in female.

Male can also seal against 45° flared tubing with nut and sleeve.

7/16 - 20, 1/2 - 20, 3/4 - 16 & 7/8 - 14 are the same thread form as

JIC 37° flare. Some fittings in these sizes have both JIC 37° & SAE 45° seats.

MALE THREAD OD & PITCH	DASH SIZE	MALE THREAD OD		FEMALE THREAD ID		TUBE SIZE
inch - TPI		mm	inch	mm	inch	inch
5/16 - 24	-05	7,9	0.31	6,8	0.27	1/8
3/8 - 24	-06	9,5	0.38	8,4	0.33	3/16
7/16 - 20	-07	11,1	0.44	9,9	0.39	1/4
1/2 - 20	-08	12,7	0.50	11,4	0.44	5/16
5/8 - 18	-10	15,9	0.63	14,2	0.56	3/8
3/4 - 16	-12	19,1	0.75	17,5	0.69	1/2
7/8 - 14	-14	22,2	0.88	20,6	0.81	5/8
1.1/16 - 14	-17	27,0	1.06	24,9	0.98	3/4

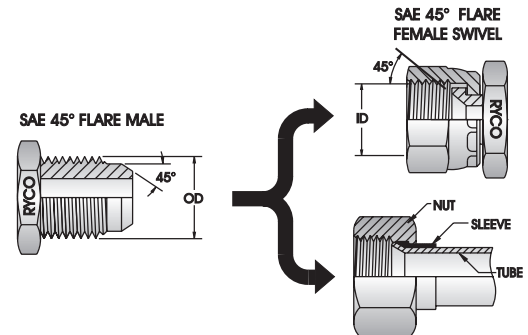

### SAE 45° INVERTED FLARE

SAE J512

MALE THREAD OD & PITCH	DASH SIZE	MALE THREAD OD		FEMALE THREAD ID		TUBE SIZE
inch - TPI		mm	inch	mm	inch	inch
7/16 - 24	-07	11,1	0.44	9,9	0.39	1/4
1/2 - 20	-08	12,7	0.50	11,4	0.45	5/16
5/8 - 18	-10	15,9	0.63	14,2	0.56	3/8
11/16 - 18	-11	17,5	0.69	16,0	0.63	7/16

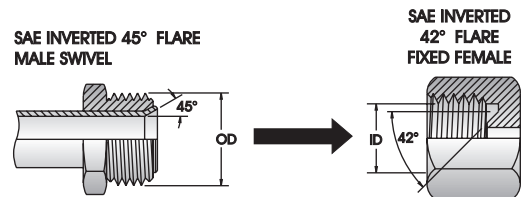

### SAE PILOT O RING SEALS PILOT MALE SWIVEL

MALE THREAD OD & PITCH	DASH SIZE	MALE THREAD OD		FEMALE THREAD ID		TUBE SIZE
inch - TPI		mm	inch	mm	inch	Dash
5/8 - 18	-10	15,9	0.63	14,2	0.56	-6
3/4 - 18	-12	19,0	0.75	17,8	0.70	-8
7/8 - 18	-14	22,2	0.88	20,6	0.81	-10

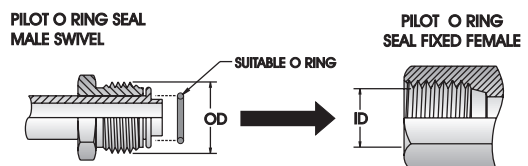

### PILOT FEMALE SWIVEL

MALE THREAD OD & PITCH	DASH SIZE	MALE THREAD OD		FEMALE THREAD ID		TUBE SIZE
inch - TPI		mm	inch	mm	inch	Dash
5/8 - 18	-10	15,9	0.63	14,2	0.56	-6
3/4 - 16	-12	19,0	0.75	17,5	0.69	-8
7/8 - 14	-14	22,2	0.88	20,6	0.81	-10

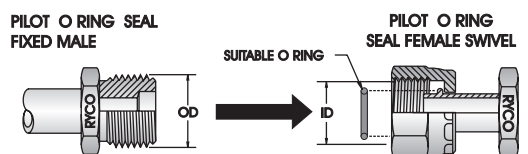

## THREAD AND CONNECTOR IDENTIFICATION

**SAE O RING FLANGE - CODE 61 & CODE 62 SAE J518, ISO 6162**  
**RYCO O RING FLANGE - CODE 62C**

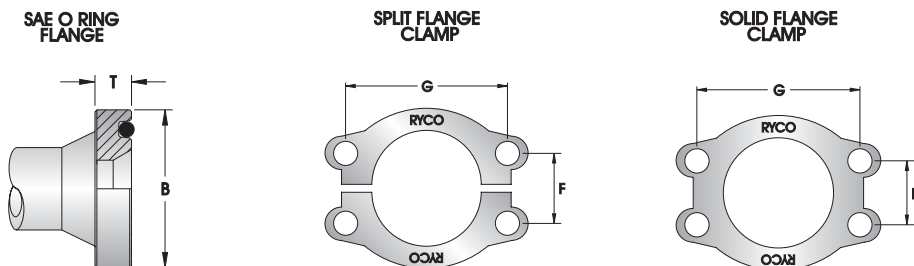

The male connector has a flange head with an O Ring groove on the face. The female can be a flange block or port with smooth face to accept the O Ring, and four threaded bolt holes in a rectangular pattern. The connection is held together using either a split or solid flange clamp, fitted over the male flange head and drawn up to the female port using the four bolts. This compresses the O Ring forming a seal between the male flange and the flat female port face.

SAE J518, DIN 20066, ISO/DIS 6162 and JIS B 8363 are all interchangeable, except for bolt sizes.

NOM. FLANGE SIZE	DASH SIZE	BØ		T		F		G		PORT THREAD & BOLT LENGTH			
		mm	inch	mm	inch	mm	inch	mm	inch	PORT	BOLT LENGTH	PORT	BOLT
inch		mm	inch	mm	inch	mm	inch	mm	inch	UNC	inch	METRIC	mm
<b>CODE 61</b>													
1/2	-08	30,2	1.19	6,73	0.265	17,5	0.69	38,1	1.50	5/16 - 18	1.1/4	M8 x 1,25	35
*5/8	-10	34,0	1.34	6,73	0.265	19,8	0.78	42,9	1.69	5/16 - 18	1.1/4	M8 x 1,25	35
3/4	-12	38,1	1.50	6,73	0.265	22,2	0.88	47,6	1.88	3/8 - 16	1.1/4	M10 x 1,5	35
1	-16	44,5	1.75	8,00	0.315	26,2	1.03	52,4	2.06	3/8 - 16	1.1/4	M10 x 1,5	35
1.1/4	-20	50,8	2.00	8,00	0.315	30,2	1.19	58,7	2.31	7/16 - 14	1.1/2	M10 x 1,5	40
1.1/2	-24	60,3	2.38	8,00	0.315	35,7	1.41	69,8	2.75	1/2 - 13	1.1/2	M12 x 1,75	45
2	-32	71,4	2.81	9,53	0.375	42,9	1.69	77,8	3.06	1/2 - 13	1.1/2	M12 x 1,75	45
2.1/2	-40	84,1	3.31	9,53	0.375	50,8	2.00	88,9	3.50	1/2 - 13	1.3/4	M12 x 1,75	45
3	-48	101,6	4.00	9,53	0.375	61,9	2.44	106,4	4.19	5/8 - 11	1.3/4	M16 x 2,0	45
<b>CODE 62</b>													
1/2	-08	31,7	1.25	7,75	0.305	18,2	0.72	40,5	1.59	5/16 - 18	1.1/4	M8 x 1,25	35
3/4	-12	41,3	1.63	8,76	0.345	23,8	0.94	50,8	2.00	3/8 - 16	1.1/2	M10 x 1,5	40
1	-16	47,6	1.88	9,53	0.375	27,8	1.09	57,2	2.25	7/16 - 14	1.3/4	M12 x 1,75	45
1.1/4	-20	54,0	2.12	10,29	0.405	31,8	1.25	66,7	2.63	1/2 - 13	1.3/4	M14 x 2,0	45
1.1/2	-24	63,5	2.50	12,57	0.495	36,5	1.44	79,4	3.13	5/8 - 11	2.1/4	M16 x 2,0	60
2	-32	79,4	3.13	12,57	0.495	44,5	1.75	96,8	3.81	3/4 - 10	2.3/4	M20 x 2,5	70
<b>RYCO CODE 62C</b>													
3/4	-12	41,3	1.63	14,20	0.559	23,8	0.94	50,8	2.00	3/8 - 16	1.3/4	M10 x 1,5	45
1	-16	47,6	1.88	14,20	0.559	27,8	1.09	57,2	2.25	7/16 - 14	1.3/4	M12 x 1,75	45
1.1/4	-20	54,0	2.12	14,20	0.559	31,8	1.25	66,7	2.63	1/2 - 13	2	M14 x 2,0	50
1.1/2	-24	63,5	2.5	14,20	0.559	36,5	1.44	79,4	3.13	5/8 - 11	2.1/2	M16 x 2,0	60
2	-32	79,4	3.13	14,20	0.559	44,5	1.75	96,8	3.81	3/4 - 10	2.3/4	M20 x 2,5	70

RYCO Code 62C fittings conform to the flange OD and bolt hole patterns of SAE Code 62 but require special flange clamp halves.

The RYCO Code 62C flange heads are thicker than SAE Code 62 and measure T = 14,2 mm (0.559") in all sizes.

RYCO Code 62C flanges have similar dimensions to the Caterpillar XT-5 and XT-6 range of flanges.

Cat™ Caterpillar®, XT-5™, XT-6™ Caterpillar®.

INTRODUCTION

HOSE

COUPLINGS

ADAPTORS

TECHNICAL

# TECHNICAL

## THREAD AND CONNECTOR IDENTIFICATION

### SAE O RING FLANGE BLOCKS - CODE 61 & CODE 62

SAE J518, ISO 6162

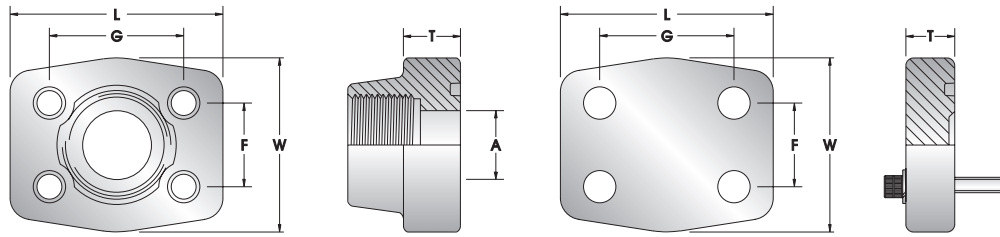

NOM. FLANGE SIZE	DASH SIZE	L		W		F		G		A		T EXCEPT BLIND FLANGES		T T BLIND FLANGES S967/S968	
		mm	inch	mm	inch	mm	inch	mm	inch	mm	inch	mm	inch	mm	inch
<b>CODE 61</b>															
1/2	-08	56	2.20	48	1.89	17,5	0.69	38,1	1.50	13	0.51	16	0.63	16	0.63
3/4	-12	65	2.56	50	1.97	22,2	0.88	47,6	1.88	19	0.75	18	0.71	16	0.63
1	-16	70	2.76	60	2.36	26,2	1.03	52,4	2.06	25	0.98	18	0.71	19	0.75
1.1/4	-20	79	3.11	68	2.68	30,2	1.19	58,7	2.31	32	1.26	21	0.83	18	0.71
1.1/2	-24	93	3.66	78	3.07	35,7	1.41	69,8	3.06	38	1.50	25	0.98	20	0.79
2	-32	102	4.02	90	3.54	42,9	1.69	77,8	3.50	51	2.01	25	0.98	20	0.79
<b>CODE 62</b>															
3/4	-12	71	2.80	60	2.36	23,8	0.94	50,8	2.00	19	0.75	21	0.83	19	0.75
1	-16	81	3.19	70	2.76	27,8	1.09	57,2	2.25	25	0.98	25	0.98	24	0.94
1.1/4	-20	95	3.74	78	3.07	31,8	1.25	66,7	2.63	32	1.26	27	1.06	27	1.06
1.1/2	-24	112	4.41	94	3.70	36,5	1.44	79,4	3.13	38	1.50	30	1.18	30	1.18
2	-32	134	5.28	114	4.49	44,5	1.75	96,8	3.81	51	2.01	37	1.46	28	1.10

NOM. FLANGE SIZE	DASH SIZE	SOCKET HEAD CAP SCREW (THREAD X LENGTH)	
		UNC x inch	METRIC x mm
<b>CODE 61</b>			
1/2	-08	5/16 - 18 x 1.1/4	M8x1,25 X 30
3/4	-12	3/8 - 16 x 1.1/2	M10x1,5 X 35
1	-16	3/8 - 16 x 1.1/2	M10x1,5 X 35
1.1/4	-20	7/16 - 14 x 1.3/4	M10x1,5 X 40
1.1/2	-24	1/2 - 13 x 1.3/4	M12x1,75 X 45
2	-32	1/2 - 13 x 1.3/4	M12x1,75 X 45
<b>CODE 62</b>			
3/4	-12	3/8 - 16 x 1.1/2	M10x1,5 X 40
1	-16	7/16 - 14 x 1.3/4	M12x1,75 X 45
1.1/4	-20	1/2 - 13 x 1.3/4	M14x2,0 X 45
1.1/2	-24	5/8 - 11 x 2	M16x2,0 X 50
2	-32	3/4 - 10 x 2.1/2	M20x2,5 X 70

## THREAD AND CONNECTOR IDENTIFICATION

### RYCOLOK SAE J1467

### SUPERLOK

RYCOLOK ARE ALSO CALLED CLIP FASTENER & STAPLE

The RYCOLOK male connector uses an O Ring and back up washer, and seals on the smooth bore of the female. The connection is held together by the staple. The male staple groove (G) aligns with the drilled holes of the female allowing the staple to be inserted. RYCOLOK and SUPERLOK use different width staples and are therefore NOT interchangeable.

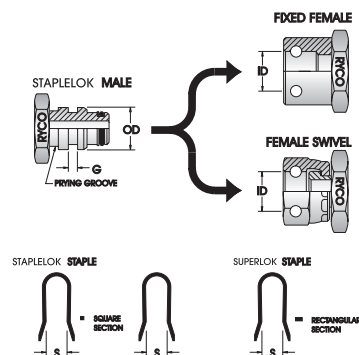

NOMINAL SIZE			NOM. MALE OD & FEMALE ID		RYCOLOK STAPLE SIZE				SUPERLOK STAPLE SIZE			
DN	inch	Dash	mm	inch	G	G	S	S	G	G	S	S
			mm	inch	mm	inch	mm	inch	mm	inch	mm	inch
6	1/4	-06	15	0.59	5,1	0.2	8	0.31	-	-	-	-
10	3/8	-10	20	0.79	5,1	0.2	13	0.51	-	-	-	-
12	1/2	-13	24	0.94	5,1	0.2	17	0.67	-	-	-	-
16	5/8	-16	26	1.02	5,1	0.2	19	0.75	-	-	-	-
19	3/4	-20	29	1.14	5,1	0.2	22	0.87	9	0.35	22	0.87
25	1	-25	39	1.53	7,1	0.28	29	1.14	13	0.51	29	1.14
31	1.1/4	-32	46	1.81	7,1	0.28	36	1.42	13	0.51	36	1.42
38	1.1/2	-40	55	2.16	7,1	0.28	45	1.77	13	0.51	45	1.77
51	2	-50	64	2.52	7,1	0.28	54	2.13	13	0.51	54	2.13

INTRODUCTION

HOSE

COUPLINGS

ADAPTORS

TECHNICAL

### RYCO WEO CARTRIDGE & CARTRIDGE PORT SPECIFICATIONS

PLUG-IN SIZE			TO SUIT RYCO WEO CARTRIDGE	A	B	C	D	E	F	G	H	J	K	L	ASSEMBLY TORQUE
DN	Dash	inch	PART No	mm	mm	mm	mm	thread	mm	mm	mm	mm	mm	mm	Nm
6	-04	1/4	<b>RW800-04</b>	10.03 +0.08	12.75 +0.10	16.55 +0.07	17.0 +0.1	M18x1,0	8.5 +1	1.1 -0.1	10.65 +0.1	14.15 +0.2	19.65 +0.15	0.2	25-35
10	-06	3/8	<b>RW800-06</b>	13.03 +0.08	16.95 +0.15	20.55 +0.07	21.0 +0.1	M22x1,0	8.7 +1	1.15 -0.1	11.1 +0.1	15.5 +0.2	21.95 +0.15	0.2	30-40
12	-08	1/2	<b>RW800-08</b>	16.03 +0.08	19.95 +0.15	23.55 +0.07	24.0 +0.1	M25x1,0	8.7 +1	1.25 -0.1	11.3 +0.1	15.7 +0.2	22.15 +0.15	0.3	40-50
19	-12	3/4	<b>RW800-12</b>	23.03 +0.08	27.95 +0.15	31.05 +0.07	31.5 +0.1	M33x1,5	11.5 +1	1.7 -0.1	16.5 +0.1	21.4 +0.2	31.35 +0.15	0.3	70-80

#### AVAILABLE RYCO WEO CARTRIDGE SIZES:

DN6 (1/4") RW800-04  
 DN10 (3/8") RW800-06  
 DN12 (1/2") RW800-08  
 DN19 (3/4") RW800-12

#### WORKING PRESSURE:

DN6 to DN19 (1/4" to 3/4")  
 350 bar (5,100 psi)

#### MINIMUM BURST PRESSURE:

DN6 to DN19 (1/4" to 3/4")  
 1400 bar (20,400 psi)

#### TEMPERATURE RANGE:

-30°C to +100°C (-22°F to 212°F)

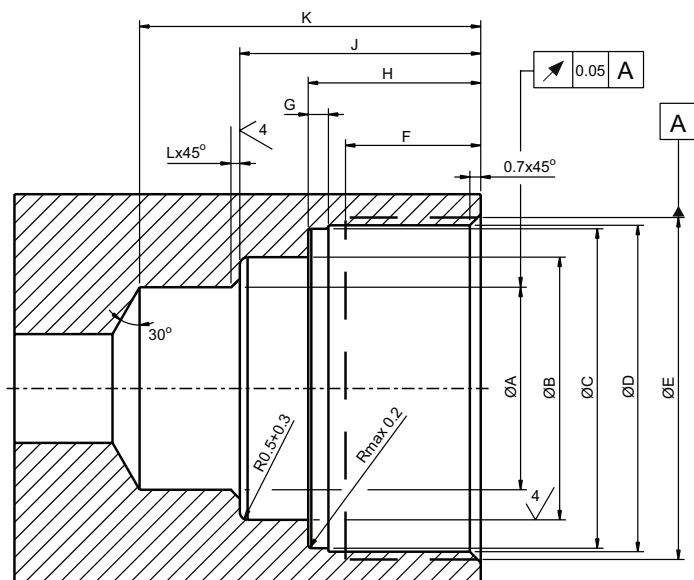

Sharp edges to be deburred 0.05-0.20 mm  
 Dimension in millimeters

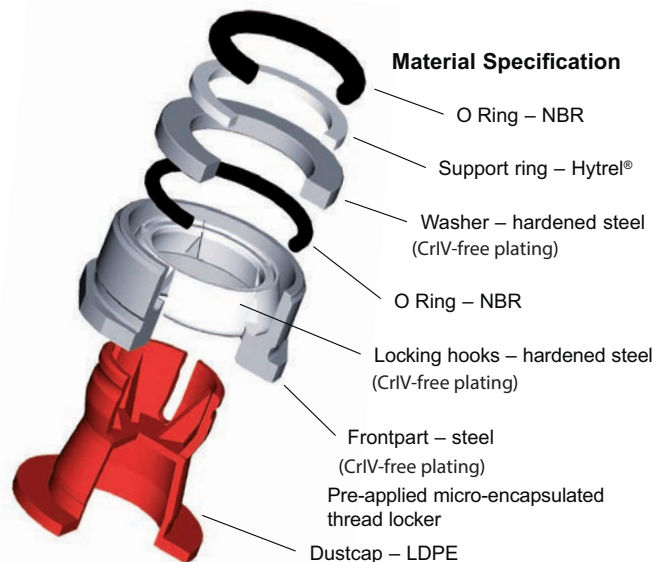

## TORQUE ASSEMBLY VALUES

The Torque Values shown are for guidance only and are based on normal industrial applications. The Torque Values shown are for plated carbon steel fittings.

**NM = NEWTON METRES**

**KG.M = KILOGRAM METRES**

**FT.LBF = FOOT POUNDS FORCE**

TO CONVERT	» INTO »	MULTIPLY BY
Nm	ft.lbf	0.737
Nm	kg.m	0.102
ft.lbf	Nm	1.357
ft.lbf	kg.m	0.138
kg.m	Nm	9.804
kg.m	ft.lbf	7.231

INTRODUCTION

HOSE

COUPLINGS

ADAPTORS

TECHNICAL

### BSPP & BSPO

BSPP SIZE	DASH SIZE	BSPP / BSPO SWIVEL NUT		BSP ENCAPSULATED SEAL		BSP BONDED SEAL			
		TORQUE RANGE		SAE RECOMMENDED TORQUE RANGE		RECOMMENDED TORQUE (SINGLE)		RECOMMENDED TORQUE (TANDEM SEALING)	
		Nm	ft.lbf	Nm	ft.lbf	Nm	ft.lbf	Nm	ft.lbf
1/8	-02	11-12	8-9	35-39	26-28	25-28	18-20	40-45	29-32
1/4	-04	25-28	18-20	60-66	44-49	51-55	37-40	67-72	49-52
3/8	-06	41-48	30-35	95-105	70-77	80-89	59-65	104-116	77-85
1/2	-08	72-82	55-60	130-143	96-105	99-105	73-77	119-126	88-93
5/8	-10	96-110	70-80	180-198	133-146	136-146	100-107	150-161	110-118
3/4	-12	124-137	90-100	200-220	147-162	220-230	162-169	242-253	179-186
1	-16	151-165	110-120	450-495	332-365	371-407	273-300	409-448	301-330
1.1/4	-20	192-206	140-150	500-550	369-405	501-510	369-376	527-536	388-395
1.1/2	-24	261-275	190-200	600-660	442-486	601-611	443-450	632-642	466-473
2	-32	343-357	250-260	700-770	516-567	746-756	550-557	784-794	578-585

\*2" (-32) sizes of BSP Encapsulated Seal use an O-Ring seal.

### METRIC

24°, 60° & UNIVERSAL INVERTED CONE					BONDED SEAL					
THREAD SIZE	TUBE DIA. S-HEAVY mm	TUBE DIA. L-LIGHT mm	SWIVEL NUT TORQUE RANGE		THREAD SIZE	DASH SIZE	RECOMMENDED TORQUE (SINGLE)		RECOMMENDED TORQUE (TANDEM SEALING)	
			Nm	ft.lbf			Nm	ft.lbf	Nm	ft.lbf
M12 x 1,5		6	10-20	7-15	M10	-10	53-59	39-43	85-95	63-69
M14 x 1,5	6	8	20-35	15-26	M12	-12	55-60	40-44	88-96	64-71
M16 x 1,5	8	10	25-40	18-30	M14	-14	72-79	53-58	101-111	75-82
M18 x 1,5	10	12	30-45	22-33	M16	-16	80-89	59-65	104-116	77-85
M20 x 1,5	12		35-50	26-37	M18	-18	82-90	60-66	107-117	78-86
M22 x 1,5	14	15	40-70	30-52	M20	-20	99-109	73-80	119-131	88-96
M24 x 1,5	16		40-70	30-52	M22	-22	136-150	100-110	157-173	115-127
M26 x 1,5		18	60-100	44-74	M24	-24	147-162	108-119	170-187	125-137
M30 x 2,0	20	22	80-120	59-89	M26	-26	171-182	126-134	189-201	139-148
M36 x 2,0	25	28	100-150	74-111	M27	-27	220-235	162-173	242-259	179-191
M42 x 2,0	30		150-220	111-163	M30	-30	270-287	199-211	297-316	219-233
M45 x 2,0		35	180-250	133-184	M33	-33	371-392	273-289	409-432	301-318
M52 x 2,0	38	42	200-300	148-221	M36	-36	390-398	287-293	429-438	316-323
					M42	-42	405-413	298-304	446-455	328-335
					M48	-48	501-510	369-376	552-561	406-414



# TECHNICAL

## TORQUE ASSEMBLY VALUES

### JSEAL™

JSEAL™ THREAD SIZE	DASH SIZE	SAE RECOMMENDED NUT TORQUE VALUE	
		Nm	ft.lbf
7/16 - 20	-07	23	17
1/2 - 20	-08	30	22
9/16 - 18	-09	39	29
3/4 - 16	-12	77	57
7/8 - 14	-14	142	105
1.1/16 - 12	-17	198	146
1.3/16 - 12	-19	235	173
1.5/16 - 12	-21	263	194
1.5/8 - 12	-26	309	228
1.7/8 - 12	-30	386	285
2.1/2 - 12	-40	597	440

### JIC 37° & SAE 45° (MACHINED OR FLARED)

JIC/SAE THREAD SIZE	DASH SIZE	SAE RECOMMENDED SWIVEL NUT TORQUE RANGE	
		Nm	ft.lbf
5/16 - 24	-05	8-9	6-7
3/8 - 24	-06	11-12	8-9
7/16 - 20	-07	15-16	11-12
1/2 - 20	-08	19-21	14-15
9/16 - 18	-09	24-28	18-20
3/4 - 16	-12	49-53	36-39
7/8 - 14	-14	77-85	57-63
1.1/16 - 12	-17	107-119	79-88
1.3/16 - 12	-19	127-140	94-103
1.5/16 - 12	-21	147-154	108-113
1.5/8 - 12	-26	172-181	127-133
1.7/8 - 12	-30	215-226	158-167
2.1/2 - 12	-40	332-350	245-258

### SAE FLANGE CLAMP BOLTS CODE 61 & 62

BOLT DATA UN CLASS 2A (THREAD X LENGTH)	FLANGE DASH SIZE	SAE RECOMMENDED BOLT TORQUE RANGE	
		Nm	ft.lbf
<b>CODE 61</b>			
5/16 - 18 X 1.1/4	-08	20-25	15-18
3/8 - 16 X 1.1/4	-12	28-40	21-29
3/8 - 16 X 1.1/4	-16	37-48	27-35
7/16 - 14 X 1.1/2	-20	48-62	35-46
1/2 - 13 X 1.1/2	-24	62-79	46-58
1/2 - 13 X 1.1/2	-32	73-90	54-66
1/2 - 13 X 1.3/4	-40	107-124	79-91
5/8 - 11 x 1.3/4	-48	186-203	138-150

<b>CODE 62</b>			
5/16 - 18 X 1.1/4	-08	20-25	15-18
3/8 - 16 X 1.1/2	-12	34-45	25-33
7/16 - 14 X 1.3/4	-16	56-68	41-50
1/2 - 13 X 1.3/4	-20	85-102	63-75
5/8 - 11 X 2.1/4	-24	158-181	116-133
3/4 - 10 X 2.3/4	-32	271-294	200-217

### UNO (O RING BOSS)

UNO THREAD SIZE	DASH SIZE	SAE RECOMMENDED STRAIGHT FITTING OR LOCK NUT TORQUE RANGE	
		Nm	ft.lbf
3/8 - 24	-06	11-13	8-10
7/16 - 20	-07	20-22	14-16
1/2 - 20	-08	24-27	18-20
9/16 - 18	-09	33-35	24-26
3/4 - 16	-12	68-78	50-60
7/8 - 14	-14	98-110	72-82
1.1/16 - 12	-17	170-183	125-135
1.3/16 - 12	-19	230-260	170-190
1.5/16 - 12	-21	270-300	200-220
1.5/8 - 12	-26	285-380	210-280
1.7/8 - 12	-30	370-490	270-360

### ORFS

ORFS THREAD SIZE	DASH SIZE	SAE RECOMMENDED SWIVEL NUT TORQUE RANGE	
		Nm	ft.lbf
9/16 - 18	-09	14-16	10-12
11/16 - 16	-11	24-27	18-20
13/16 - 16	-13	43-47	32-35
1 - 14	-16	60-68	46-50
1.3/16 - 12	-19	90-95	65-70
1.7/16 - 12	-23	125-135	92-100
1.11/16 - 12	-27	170-190	125-140
2-12	-32	200-225	150-165

### SAE FLANGE BLOCK BOLTS CODE 61 & 62

BOLT DATA UN CLASS 2B (THREAD X LENGTH)	FLANGE DASH SIZE	RECOMMENDED BOLT TORQUE RANGE	
		Nm	ft.lbf
<b>CODE 61</b>			
5/16 - 18 X 1.1/4	-08	20-25	15-18
3/8 - 16 X 1.1/2	-12	28-40	21-29
3/8 - 16 X 1.1/2	-16	37-48	27-35
7/16 - 14 X 1.3/4	-20	48-62	35-46
1/2 - 13 X 1.3/4	-24	62-79	46-58
1/2 - 13 X 1.3/4	-32	73-90	54-66

<b>CODE 62</b>			
3/8 - 16 X 1.1/2	-12	34-45	25-33
7/16 - 14 X 1.3/4	-16	56-68	41-50
1/2 - 13 X 1.3/4	-20	85-102	63-75
5/8 - 11 X 2	-24	158-187	116-138
3/4 - 10 X 2.1/2	-32	271-294	200-217

<b>AF</b>	Across Flats	<b>EXT</b>	Extended	<b>NB</b>	Nominal Bore
<b>ABS, Abs.</b>	Absolute	<b>F, FEM</b>	Female	<b>NCB</b>	National Coal Board
<b>ABS</b>	American Bureau of Shipping	<b>FF</b>	Female Fixed	<b>NCS</b>	NATA Certification Services
<b>AC</b>	Air Conditioning	<b>FIX</b>	Fixed	<b>NFPA</b>	National Fluid Power Association (USA)
<b>AGA</b>	Australian Gas Association	<b>FLNG</b>	Flange	<b>Nm</b>	Newton Metre
<b>API</b>	American Petroleum Institute	<b>FOS</b>	Factor Of Safety	<b>NOM, Nom.</b>	Nominal
<b>AS</b>	Australian Standard	<b>FS</b>	Female Swivel	<b>NPS</b>	National Pipe Straight Thread
<b>AV</b>	Average	<b>ft</b>	Foot	<b>NPSM</b>	National Pipe Straight Mechanical
<b>BCS</b>	British Coal Standard	<b>ft.lbf</b>	Foot Pound force	<b>NPSMFS</b>	National Pipe Straight Mechanical Female Swivel
<b>BH</b>	Bulkhead	<b>g</b>	Gram	<b>NPT</b>	National Pipe Taper Thread
<b>BP</b>	Burst Pressure	<b>GL</b>	Germanischer Lloyd	<b>NPTF</b>	National Pipe Taper for Fuel
<b>BS</b>	British Standard	<b>GPM</b>	Gallons Per Minute	<b>NPTFF</b>	National Pipe Taper Female Fixed
<b>BSP</b>	British Standard Pipe	<b>HM</b>	Hexagon, Male	<b>NPTM</b>	National Pipe Taper Male
<b>BSPP</b>	British Standard Pipe Parallel Thread	<b>HF</b>	Hexagon, Female	<b>OA, O/A</b>	Overall
<b>BSPPFS</b>	British Standard Pipe Parallel Female Swivel	<b>HP</b>	High Pressure	<b>OD</b>	Outside Diameter
<b>BSPPMBH</b>	British Standard Pipe Parallel Male Bulkhead	<b>hp</b>	Horse Power	<b>ORFS</b>	O Ring Face Seal
<b>BSPO</b>	BSPP O Ring Female Swivel	<b>HTS</b>	High Tensile Steel	<b>ORFSFS</b>	ORFS Female Swivel
<b>BSPPOM</b>	British Standard Pipe Parallel O Ring Male	<b>HW</b>	Heavy Wall	<b>ORFSM</b>	ORFS Male
<b>BSPPOM EXT</b>	British Standard Pipe Parallel O Ring Male Extended	<b>ID</b>	Inside Diameter	<b>PCD</b>	Pitch Circle Diameter
<b>BSPT</b>	British Standard Pipe Taper Thread	<b>inHg</b>	Inches of Mercury	<b>PCV</b>	Positive Crankcase Ventilation
<b>BSPTFF</b>	British Standard Pipe Taper Female Fixed	<b>IMP</b>	Imperial	<b>P/N, P/NO</b>	Part Number
<b>BSPTM</b>	British Standard Pipe Taper Male	<b>INV</b>	Inverted	<b>PREV</b>	Previous
<b>BSW</b>	British Standard Whitworth	<b>ISO</b>	International Organization for Standardization	<b>psi</b>	Pounds per Square Inch
<b>C/W</b>	Complete With	<b>JIC</b>	Joint Industries Council (Thread UN)	<b>PTFE</b>	Polytetrafluoroethylene
<b>CA</b>	Cut-off Allowance	<b>JICFS</b>	JIC Female Swivel	<b>PW</b>	Pressure Washer
<b>CAT</b>	Caterpillar®	<b>JICM</b>	JIC Male	<b>QA</b>	Quality Assurance
<b>CL, C/L</b>	Cut Length	<b>JICMBH</b>	JIC Male Bulkhead	<b>QC</b>	Quality Control
<b>CrVI</b>	Chromium 6	<b>JICMEXT</b>	JIC Male Extended	<b>QRC</b>	Quick Release Coupling
<b>cSt</b>	Centistoke	<b>JIS</b>	Japanese Industrial Standard	<b>RED</b>	Reducing
<b>DIA, DIAM</b>	Diameter	<b>kg</b>	Kilogram	<b>RMA</b>	Rubber Manufacturers Association
<b>DIN</b>	Deutsche Industrie Normen (German Industrial Standard)	<b>kg.m</b>	Kilogram Metres	<b>RPM</b>	Revolutions Per Minute
<b>DKL</b>	Dicht Kegel Leicht (Metric Light Series 24° Cone)	<b>kPa</b>	KiloPascal	<b>RQP</b>	RYCO Quality Product
<b>DKM</b>	Dicht Kegel Metric (Metric 60° Cone)	<b>kW</b>	Kilowatt	<b>SAE</b>	Society of Automotive Engineers (USA)
<b>DKO</b>	Dicht Kegel O Ring (Metric O Ring Seal 24° Cone)	<b>LNG</b>	Long	<b>SAEFS</b>	SAE Female Swivel
<b>DKOL</b>	Dicht Kegel O Ring Leicht (Metric Light O Ring Series 24° Cone)	<b>L</b>	Litre	<b>SAEM</b>	SAE Male
<b>DKOS</b>	Dicht Kegel O Ring Schwer (Metric Heavy O Ring Series 24° Cone)	<b>L</b>	Length (Couplings Section)	<b>SF</b>	Swivel Female (Union)
<b>DKS</b>	Dicht Kegel Schwer (Metric Heavy Series 24° Cone)	<b>lb</b>	Pound	<b>SS</b>	Stainless Steel
<b>DL</b>	Drop Length	<b>LP</b>	Low Pressure	<b>STD</b>	Standard
<b>DN</b>	Diameter Nominal (mm)	<b>LPG</b>	Liquified Petroleum Gas	<b>STPL</b>	Staple
<b>DNV</b>	Det Norske Veritas	<b>LPM</b>	Litres Per Minute	<b>SWIV</b>	Swivel
<b>DoT</b>	Department of Transportation (USA)	<b>LR</b>	Lloyd's Register	<b>T/NESS</b>	Thickness
<b>EEC</b>	Evaporative Emission Control	<b>M</b>	Male	<b>TBA</b>	To Be Advised
<b>ELB</b>	Elbow	<b>m</b>	Metre	<b>THRD</b>	Thread
<b>EPDM</b>	Ethylene Propylene Diene Monomer	<b>MAX</b>	Maximum	<b>TP</b>	Test Pressure
		<b>MBP</b>	Minimum Burst Pressure	<b>TPI</b>	Threads Per Inch
		<b>MED</b>	Marine Equipment Directive	<b>TW</b>	Tube Weld
		<b>MFL</b>	Minimum Free Length	<b>UN</b>	Unified National Thread
		<b>MIC, Mic.</b>	Micron (µm)	<b>UNO</b>	UN O Ring (O Ring Boss)
		<b>MIL</b>	Military Specification (USA)	<b>UNOM</b>	UNO Male (O Ring Boss Male)
		<b>MIN</b>	Minimum	<b>UNOMEXT</b>	UNO Male Extended (O Ring Boss Male Extended)
		<b>mm</b>	Millimetre	<b>USCG</b>	United States Coast Guard
		<b>mmHg</b>	Millimetres of Mercury	<b>WP</b>	Working Pressure
		<b>MPa</b>	MegaPascal	<b>°C</b>	Degrees Celcius
		<b>MSHA</b>	USA Department of Labor, Mine Safety and Health Administration.	<b>°F</b>	Degrees Fahrenheit
		<b>MWP</b>	Maximum Working Pressure	<b>β</b>	Beta (filtration)
		<b>NA, N/A</b>	Not Applicable	<b>mm</b>	Micron
		<b>NAHAD</b>	National Association of Hose and Accessories Distributors (USA)		
		<b>NATA</b>	National Association of Testing Authorities (Aus.)		

INTRODUCTION

HOSE

COUPLINGS

ADAPTORS

TECHNICAL

**RYCO LOCATIONS**

**RYCO 24•7 SERVICE CENTRES**

**AUSTRALIA**

+61 1300 111 247  
Sales@RYCO.com.au

**GLOBAL HEAD OFFICE  
MELBOURNE**  
19 Whitehall Street  
Footscray, VIC 3011

**REGIONAL LOCATIONS  
ADELAIDE**  
BL Shipway & Co  
217 Richmond Road  
Richmond, SA 5033

**BLACKWATER**  
6 Jarrah Street  
Blackwater, QLD 4717

**PERTH**  
47 Tacoma Circuit  
Canning Vale, WA 6155

**BRISBANE**  
97 Northlink Place  
Northgate, QLD 4013

**NEWCASTLE**  
14 Ironbark Close  
Warabrook, NSW 2304

**RYCO 24•7 133•24•7 Sales@RYCO247.com**

NSW	QLD	SA & NT	VIC & TAS	WA
Bellingen	Archerfield	Adelaide	Bendigo	Kalgoorlie
Boggabri	Banana	Cowell	Melbourne	Mandurah
Gunnedah	Blackwater	Darwin	Mildura	Newman
Ingleburn	Brisbane	Kadina	Shepperton	Perth
Mascot	Capricornia	Kapunda	Warrnambool	Port Hedland
Newcastle	Clermont	Loxton	Devonport	
Penrith	Dysart	Port Pirie	Launceston	
Sydney	Eagle Farm	Richmond		
Smeaton Grange	Ipswich	Riverland		
Wallerawang	Moranbah	Roxby Downs		
Woodburn	Narangba	Whyalla		
	Rocklea			
	Rolleston			

**NEW ZEALAND**

+64 800 842 872  
Sales@RYCOnz.co.nz

**NEW ZEALAND HEAD OFFICE  
AUCKLAND**  
4 Autumn Place  
Penrose, Auckland 1061

**RYCO 24•7 0800•111•24•7 Sales@RYCO247.co.nz**

NORTH ISLAND	SOUTH ISLAND
Gisborne	Christchurch
Hamilton	Blenheim
Hastings	Bluff
Kaikohe	Dovedale
Manawatu	Dunedin
Masterton	Golden Bay
Matamata	Gore
Morrinsville	Invercargill
New Plymouth	Nelson
Opoutama	Thornbury
Otorohanga	Timaru
Palmerston North	Westport
Pukekohe	Winton
Whangarei	
Whakatane	
Whitianga	
Tauranga	

**USA & CANADA**

+1 866 821 7926  
Sales@RYCO.us

**HEAD OFFICE USA & CANADA  
TEXAS**  
1616 Greens Road  
Houston, Texas 77032

**REGIONAL LOCATIONS  
CALIFORNIA**  
1150 Valencia Avenue  
Tustin, California 92780

**ONTARIO**  
32 Airpark Place  
Guelph, ONT  
Canada N1L 1B2

**IOWA**  
1007 West 10th Street  
Pella, Iowa 50219

**RYCO 24•7 1 844•700•0247 Sales@RYCO247.us**

BOSSIER CITY	HAMMOND	MICHIGAN CITY
3210 Shed Road Bossier City LA 71111	6718 Kennedy Av Hammond IN 46323	1306 West Highway 20 Michigan City IN 46360
Tel +1 318 747 7926	Tel +1 219 844 6570	Tel +1 219 844 6570

**CHINA**

**DALIAN:** +86 411 8886 0006  
**SHANGHAI:** +86 512 3306 6181  
Sales@RYCO.cn

**DALIAN**  
38 Yingri Road  
Ying Cheng Zi Industrial Zone  
Gan Jing Zi District  
Dalian 116036

**SHANGHAI**  
2nd Building, 88 Dalian East Road  
Taicang Economy Developing Area  
Taicang, Jiangsu Province 215400

**MALAYSIA SOUTH AFRICA EUROPE**

**PENANG**  
Plot 207 Kuala Ketil Ind. Estate Kuala Ketil,  
Kedah, 09300

Tel: +60 4 415 2500  
Email: Sales@RYCO.com.sg

**JOHANNESBURG**  
340 Roan Crescent  
Corporate Park North  
Randjespark, Midrand  
1685

Tel: +27 10 4100 500  
Email: Sales@RYCO.co.za

**AUSTRIA**  
Windbachgasse 10  
2721 Bad Fischau

Tel: +43 676 723 95 37  
Email: Sales@RYCO.eu